

JVC

SERVICE MANUAL

AUDIO/VIDEO CONTROL RECEIVER

RX-8010VBK

Area Suffix
 J-----U.S.A.

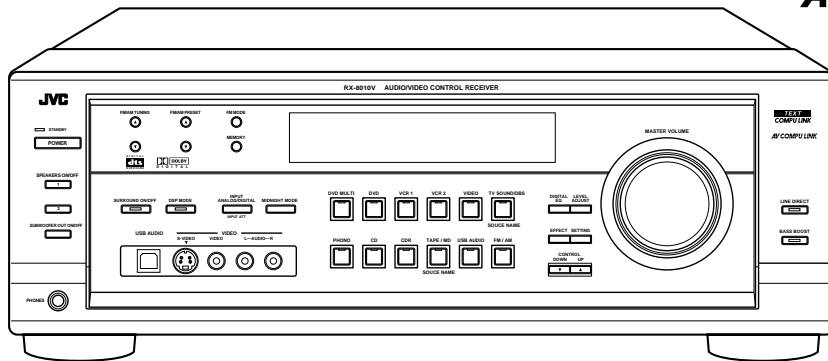
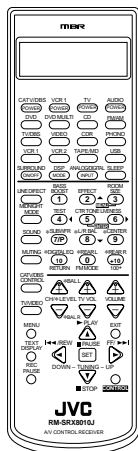

AV COMPU LINK

**TEXT
 COMPU LINK**

DIGITAL
dts
 SURROUND

DOLBY
 DIGITAL

Contents

Safety precautions -----1-2
 Importance administering point on the safety ----- 1-3
 Disassembly method -----1-4
 Adjustment method -----1-10
 Self-diagnose function -----1-11
 Description of major ICs -----1-13

Safety Precautions

1. This design of this product contains special hardware and many circuits and components specially for safety purposes. For continued protection, no changes should be made to the original design unless authorized in writing by the manufacturer. Replacement parts must be identical to those used in the original circuits. Services should be performed by qualified personnel only.
2. Alterations of the design or circuitry of the product should not be made. Any design alterations of the product should not be made. Any design alterations or additions will void the manufacturer's warranty and will further relieve the manufacture of responsibility for personal injury or property damage resulting therefrom.
3. Many electrical and mechanical parts in the products have special safety-related characteristics. These characteristics are often not evident from visual inspection nor can the protection afforded by them necessarily be obtained by using replacement components rated for higher voltage, wattage, etc. Replacement parts which have these special safety characteristics are identified in the Parts List of Service Manual. Electrical components having such features are identified by shading on the schematics and by (\triangle) on the Parts List in the Service Manual. The use of a substitute replacement which does not have the same safety characteristics as the recommended replacement parts shown in the Parts List of Service Manual may create shock, fire, or other hazards.
4. The leads in the products are routed and dressed with ties, clamps, tubings, barriers and the like to be separated from live parts, high temperature parts, moving parts and/or sharp edges for the prevention of electric shock and fire hazard. When service is required, the original lead routing and dress should be observed, and it should be confirmed that they have been returned to normal, after re-assembling.
5. Leakage current check (Electrical shock hazard testing)
After re-assembling the product, always perform an isolation check on the exposed metal parts of the product (antenna terminals, knobs, metal cabinet, screw heads, headphone jack, control shafts, etc.) to be sure the product is safe to operate without danger of electrical shock. Do not use a line isolation transformer during this check.

- Plug the AC line cord directly into the AC outlet. Using a "Leakage Current Tester", measure the leakage current from each exposed metal parts of the cabinet, particularly any exposed metal part having a return path to the chassis, to a known good earth ground. Any leakage current must not exceed 0.5mA AC (r.m.s.)

- Alternate check method

Plug the AC line cord directly into the AC outlet. Use an AC voltmeter having, 1,000 ohms per volt or more sensitivity in the following manner. Connect a 1,500 Ω 10W resistor paralleled by a 0.15 μ F AC-type capacitor between an exposed metal part and a known good earth ground.

Measure the AC voltage across the resistor with the AC voltmeter.

Move the resistor connection to each exposed metal part, particularly any exposed metal part having a return path to the chassis, and measure the AC voltage across the resistor. Now, reverse the plug in the AC outlet and repeat each measurement. voltage measured Any must not exceed 0.75 V AC (r.m.s.). This corresponds to 0.5 mA AC (r.m.s.).

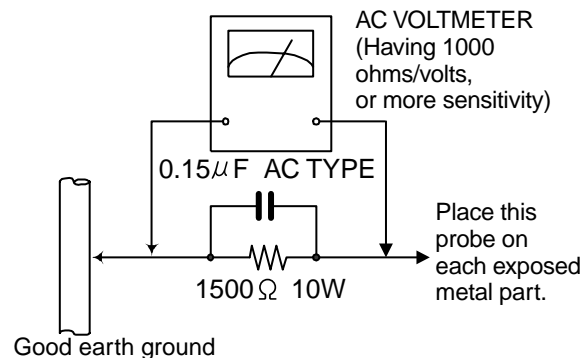

Warning

1. This equipment has been designed and manufactured to meet international safety standards.
2. It is the legal responsibility of the repairer to ensure that these safety standards are maintained.
3. Repairs must be made in accordance with the relevant safety standards.
4. It is essential that safety critical components are replaced by approved parts.
5. If mains voltage selector is provided, check setting for local voltage.

CAUTION Burrs formed during molding may be left over on some parts of the chassis. Therefore, pay attention to such burrs in the case of performing repair of this system.

Importance administering point on the safety

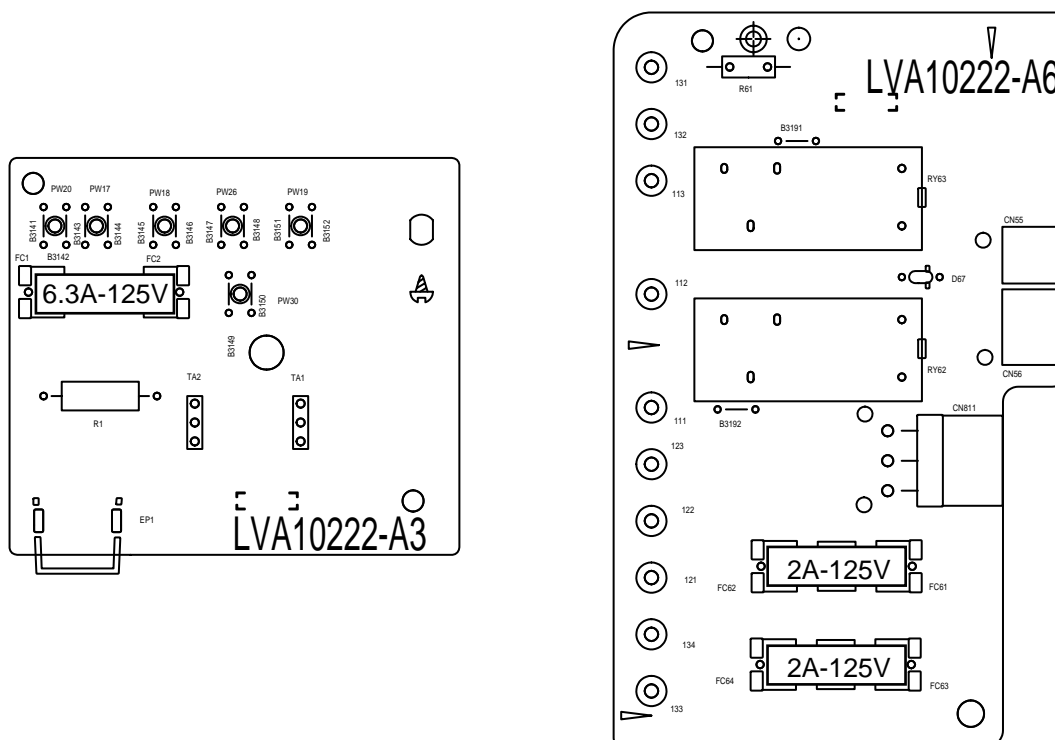

For USA and Canada / pour États - Unis d'Amérique et Canada

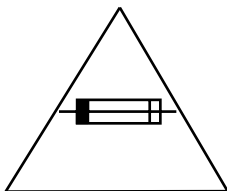

Caution: For continued protection against risk of fire, replace only with same type 6.3A/125V for F201, 2A/125V for F202 and F203. This symbol specifies type of fast operating fuse.

Précaution: Pour éviter risques de feux, remplacez le fusible de sûreté de F201 comme le même type que 6.3A/125V, et 2A/125V pour F202 et F203. Ce sont des fusibles sûretés qui fonctionnent rapide.

Disassembly method

■ Removing the top cover (See Fig.1)

1. Remove the four screws A attaching the top cover on both sides of the body.
2. Remove the three screws B on the back of the body.
3. Remove the top cover from behind in the direction of the arrow while pulling both sides outward.

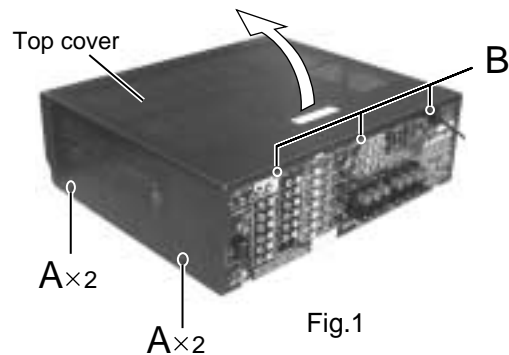

■ Removing the front panel assembly (See Fig.2 to 3)

- Prior to performing the following procedure, remove the top cover.
1. Disconnect the card wire from connector CN400 on the audio board and CN402 on the power supply board in the front panel assembly.
 2. Cut off the tie band fixing the harness.
 3. Remove the three screws C attaching the front panel assembly and the screw a fixing a ground.
 4. Remove the four screws D attaching the front panel assembly on the bottom of the body. Detach the front panel assembly toward the front.

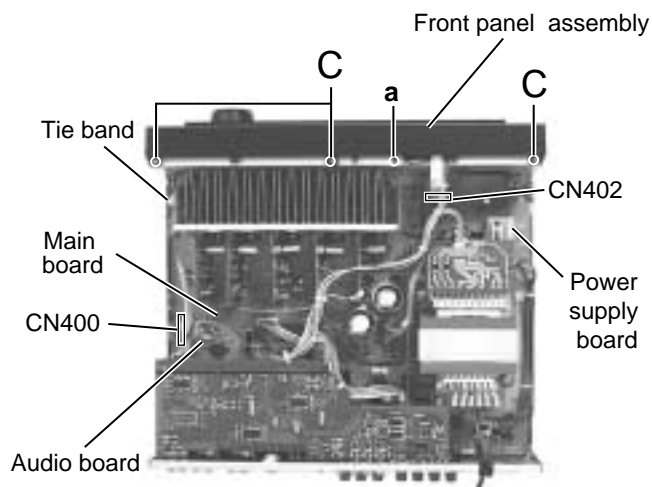

Fig.2

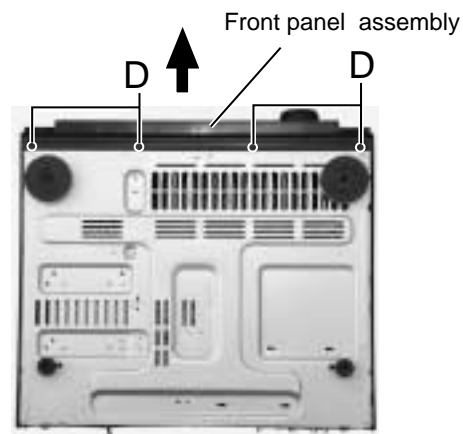

Fig.3

■ Removing the rear panel (See Fig.4)

- Prior to performing the following procedure, remove the top cover.
1. Remove the power cord stopper from the rear panel by moving it in the direction of the arrow.
 2. Remove the thirty four screws E attaching the each boards to the rear panel on the back of the body.
 3. Remove the three screws F attaching the rear panel on the back of the body.

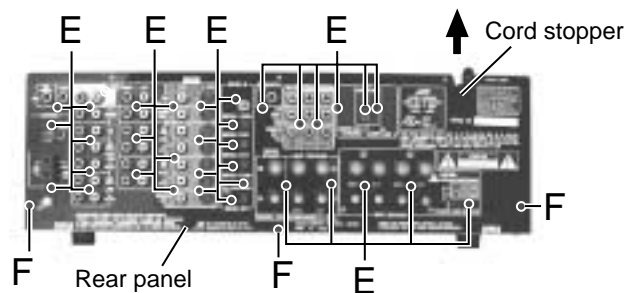

Fig.4

■ Removing each board connected to the rear side of the audio board

(See Fig.5 to 11)

- Prior to performing the following procedure, remove the top cover and the rear panel.

1. Cut off the tie band fixing the harness.
2. Disconnect the connect CN501, CN243, CN205, CN381, CN361 on the DVD board.
3. Disconnect the harness from connector CN721, CN722 and CN723.
4. Disconnect the tuner board and audio board from connector CN101 and CN301 on the audio board.
5. Pull out the video audio board, video board, S-video board.
6. Disconnect the DSP board from connector CN601 on the audio board.

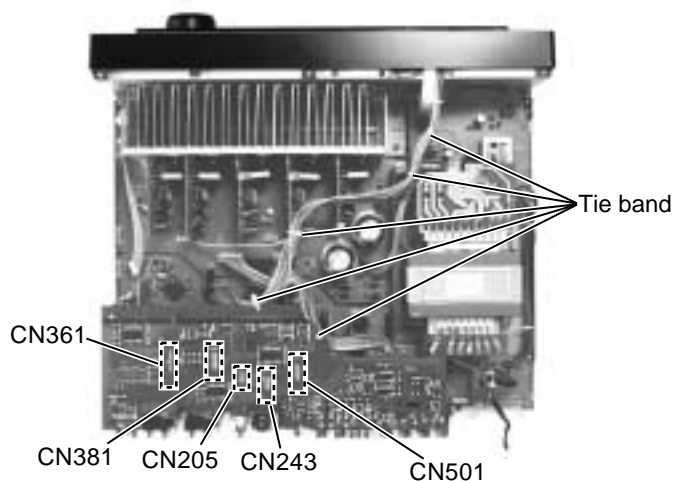

Fig.5

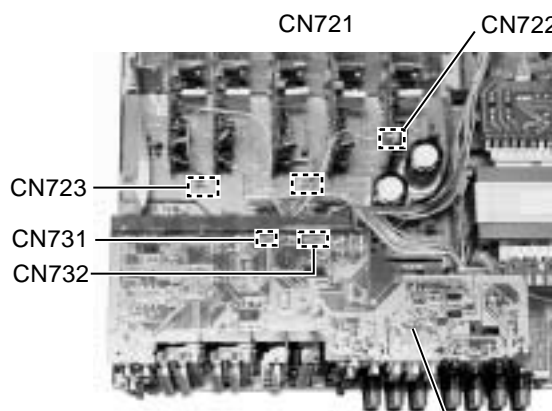

Fig.6

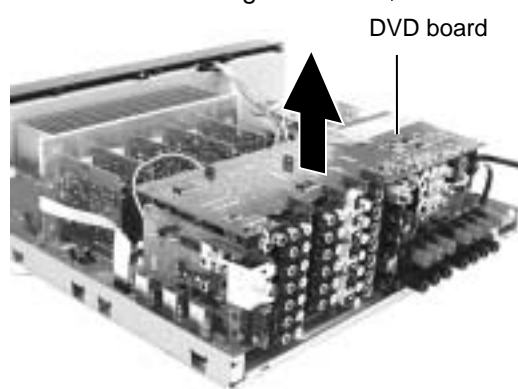

Fig.7

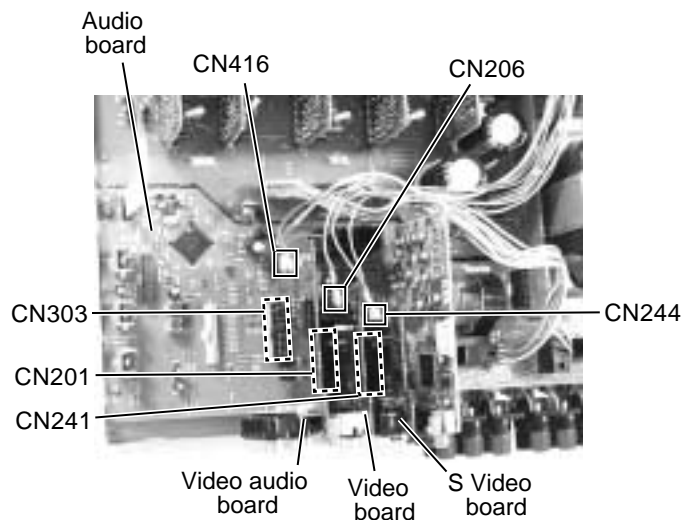

Fig.9

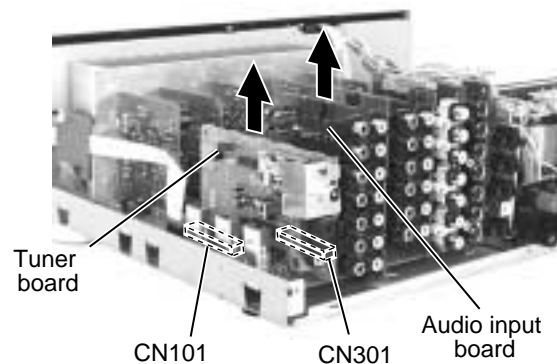

Fig.8

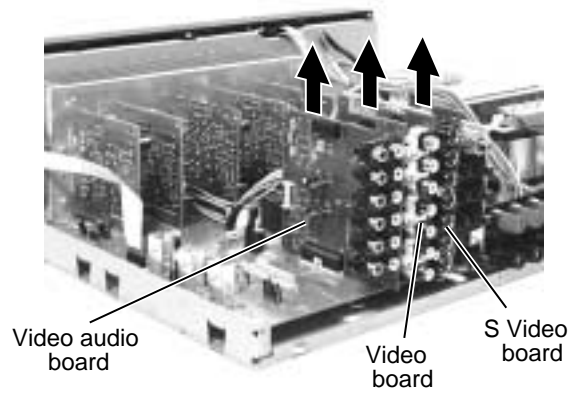

Fig.10

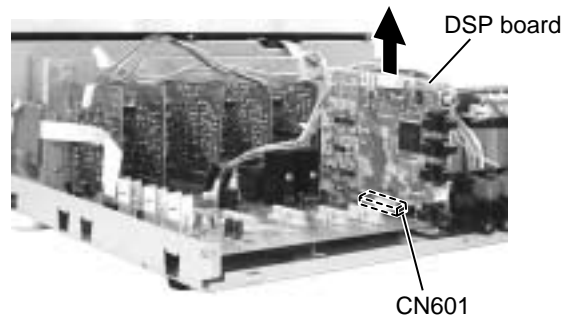

Fig.11

**■ Removing the audio board
(See Fig.12 to 13)**

- Prior to performing the following procedure, remove the top cover and the rear panel.
- 1. Disconnect the harness from connector CN813 and CN814 on the main board.
- 2. Disconnect the card wire from connector CN931 and CN932 on the audio board.
- 3. Cut off the tie band fixing the harness.
- 4. Disconnect the relay board from the audio board and the power supply board. (CN71,CN81)
- 5. Disconnect the card wire from connector CN831 on the main board.
- 6. Remove the three screws G attaching the audio board assembly.
- 7. Remove the screw H attaching the audio board assembly.

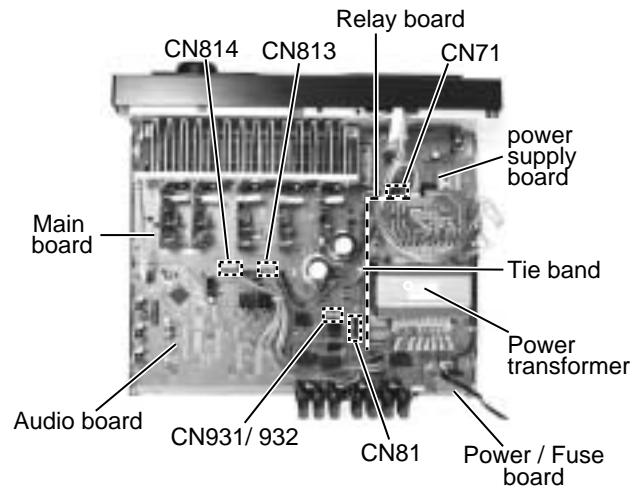

Fig.12

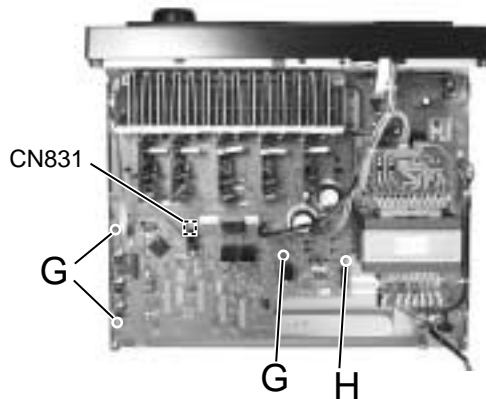

Fig.13

■ Removing the main board (See Fig.14)

- Prior to performing the following procedure, remove the top cover, the rear panel and audio board.

1. Cut off the tie band fixing the harness.
2. Disconnect the harness from connector CN811 on the power supply board respectively.
3. Disconnect the harness from connector CN881 on the main board.
4. Remove the four screws I and the two screws J attaching the main board.

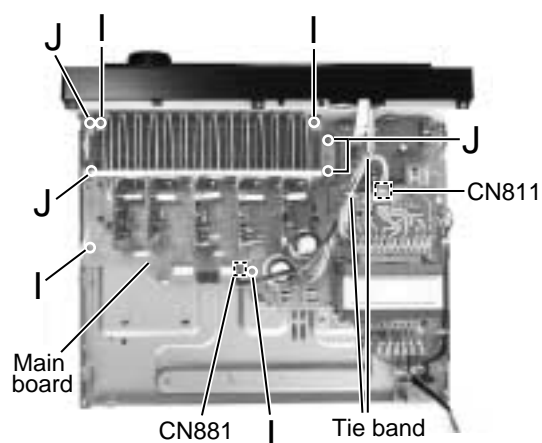

Fig.14

■ Removing the Heat sink (See Fig.15 to 16)

1. Remove the ten screws K and four screws L attaching the heat sink.
2. Remove the two screws L' attaching the heat sink from the rear side of main board.

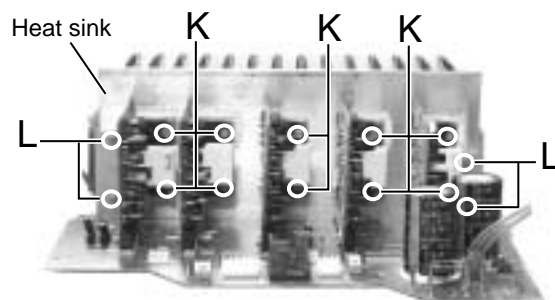

Fig.15

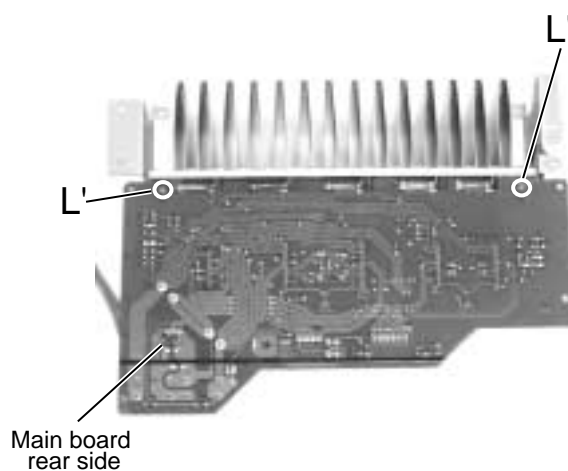

Fig.16

■ Removing the power transformer
(See Fig.17)

• Prior to performing the following procedures, remove the top cover.

1. Unsolder the two harnesses connected to the power transformer.
2. Disconnect the harness from connector CN55 and CN56 on the power transformer board.
3. Remove the four screws M attaching the power transformer.

■ Removing the power / fuse board
(See Fig.17)

• Prior to performing the following procedure, remove the top cover and the rear panel.

1. Remove the screw N attaching the power / fuse board.
2. Unsolder the power cord and other harnesses connected to the power / fuse board.

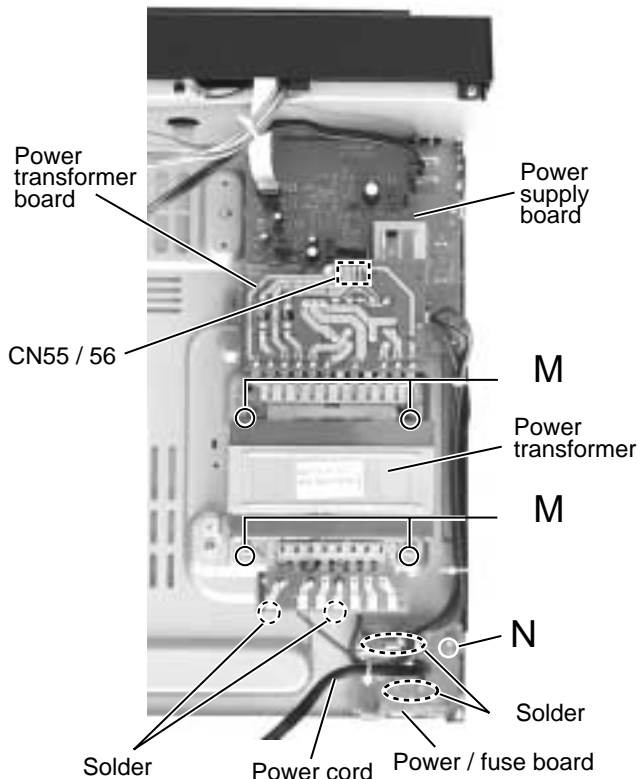

Fig.17

■ Removing the power supply board
(See Fig.18 to 19)

• Prior to performing the following procedure, remove the top cover and the front panel.

1. Remove the screws **b** fixing a bonding ground.
2. Remove the one nut attaching the headphone jack of the power supply board on the front side of the body.
3. Disconnect the card wire from connector CN402 on the power supply board.
4. Remove the three screws **O** attaching the power supply board and pull out the power supply board from the front bracket backward.
5. Unsolder the three harnesses connected to the power supply board.

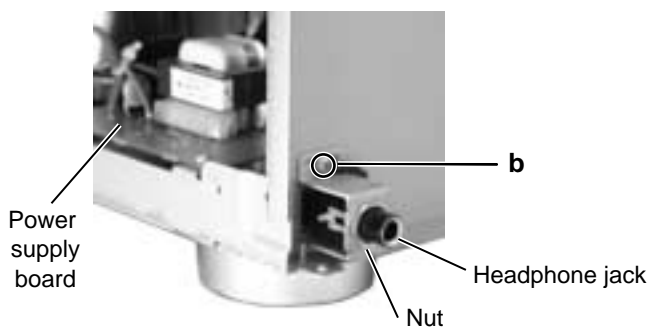

Fig.18

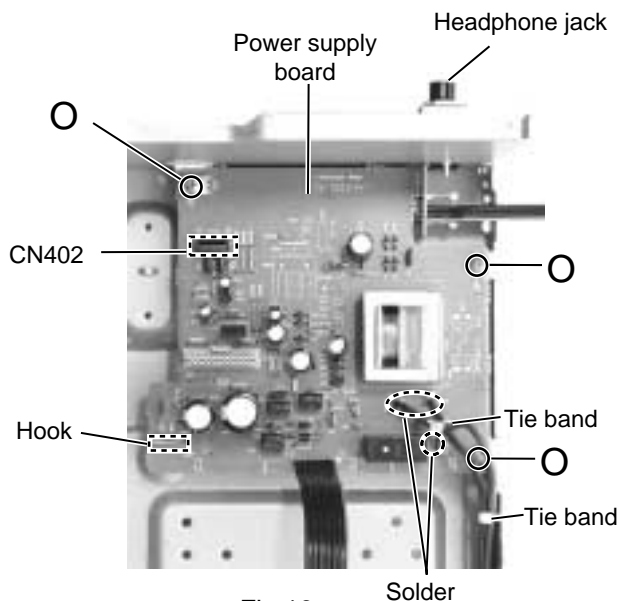

Fig.19

■ Removing the system control board / power switch board (See Fig.20 to 22)

- Prior to performing the following procedure, remove the top cover and the front panel assembly.
1. Pull out the volume knob on the front side of the front panel and remove the nut attaching the system control board.
 2. Remove the two screws P attaching the power switch board.
 3. Remove the two screws Q attaching the switch board.
 4. Remove the cords from the three hooks a.
 5. Remove the eight screws R attaching the system control board on the back of the front panel.
 6. On the back of the front panel, release the four joints by pushing the joint tabs inward. Remove the operation switch panel toward the front.
 7. Disconnect the harness from connector CN420 and CN422 on the system control board.
 8. Release the two hooks b attaching the system control board.

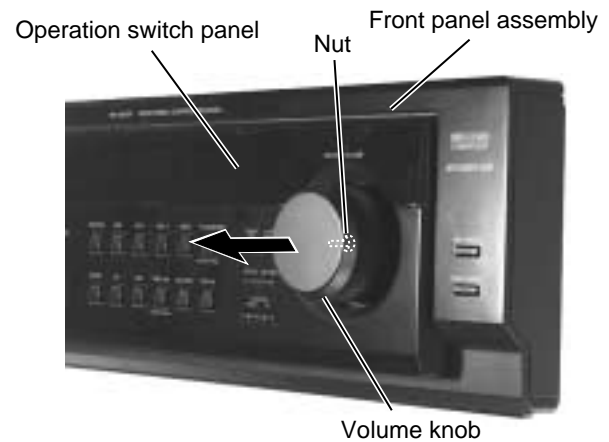

Fig.20

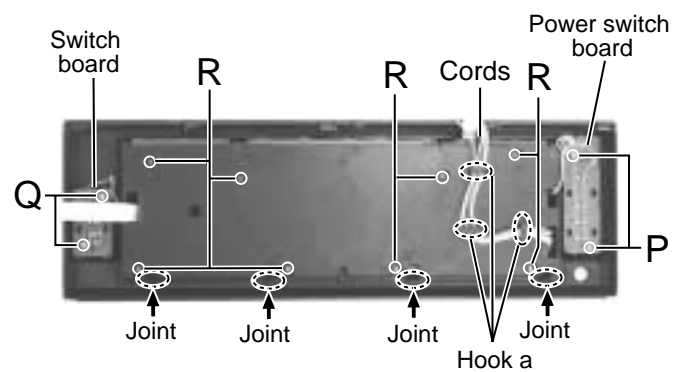

Fig.21

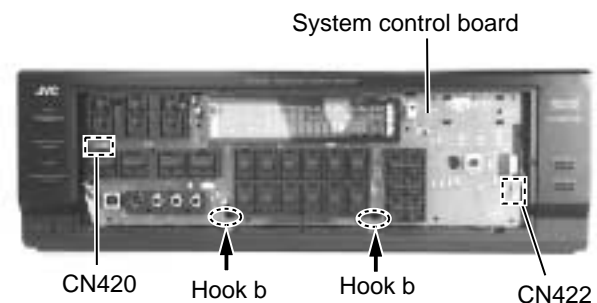
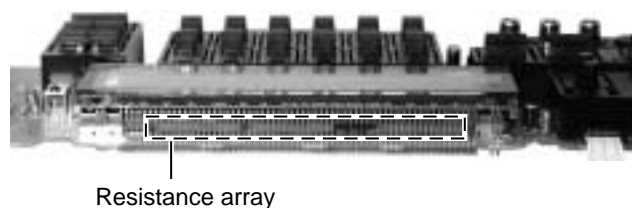

Fig.22

■ Matters that require attention during replacement of IC400

- In case where there is a resistance array:
Both onetime IC and mask IC can be used
- In case where there is no resistance array:
Only mask IC can be used



Adjustment method

■ Tuner section

1. Tuner range

FM	87.5MHz~108.0MHz
AM(MW)	530kHz~1710kHz

■ Power amplifier section

Adjustment of idling current

Measurement location	B2204-B2205(Lch) , B2213-2214(Rch)
Adjustment part	VR787(Lch) , VR788(Rch)

Attention

This adjustment does not obtain a correct adjustment value immediately after the amplifier is used (state that an internal temperature has risen). Please adjust immediately after using the amplifier after turning off the power supply of the amplifier and falling an internal temperature.

<Adjustment method>

1. Set the volume control to minimum during this adjustment. (No signal & No load)
2. Set the surround mode OFF.
2. Turn VR787 and VR788 fully counterclockwise to warm up before adjustment.
If the heat sink is already warm from previous use the correct adjustment can not be made.
3. For L-ch, connect a DC voltmeter between B2204 and B2205 (Lch)
And, connect it between B2213 and B2214 (Rch).
4. 30 minutes later after power on, adjust VR787 for L-ch, or VR788 for R-ch so that the DC voltmeter value has 1mV~10mV.

* It is not abnormal though the idling current might not become 0mA even if it is finished to turn variable resistance (VR787, VR788) in the direction of counterclockwise.

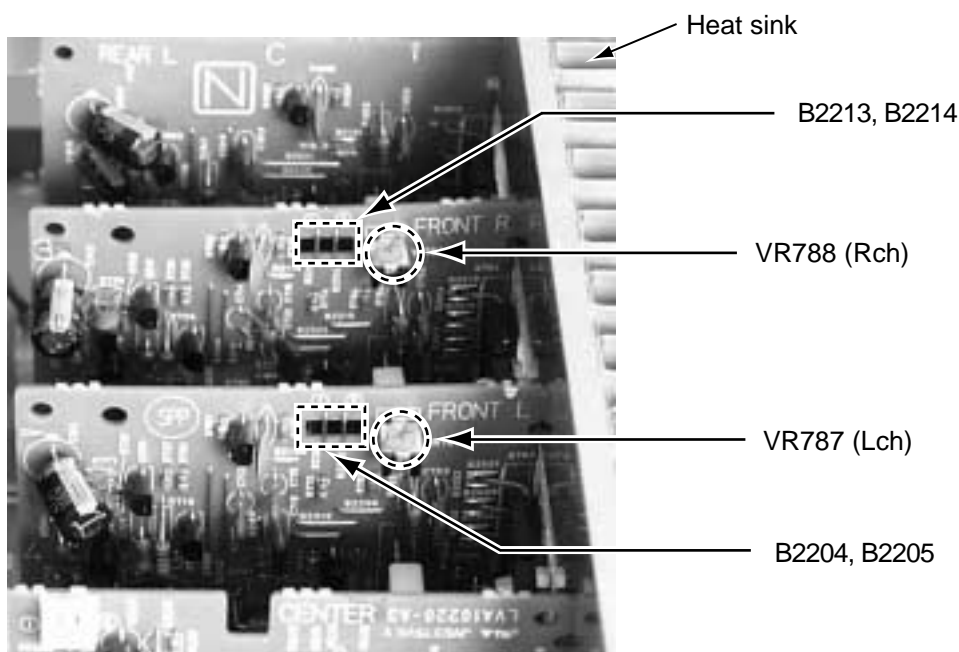

Self-diagnose function

1. Detection of abnormal power supply and voltage

- When the power is turned ON, if an abnormality is detected during the signal input at the A/D port (IC901, pin 2-5, 7) for one second continuously, the status will become STANDBY mode immediately.
- When the power is turned ON again, detection of abnormal power supply and voltage will not be carried out during the first 4 seconds.
- Given below is a list of threshold values at the detection of abnormalities.

	At abnormal state (Low voltage)	At abnormal state	At abnormal state (High voltage)
Pin 2 Micro-computer+5V	Analog value 0 - 2.2V	Analog value 2.2 - 2.8V	Analog value 2.8 - 5.0V
Pin 3 Digital+5V	Analog value 0 - 2.2V	Analog value 2.2 - 2.8V	Analog value 2.8 - 5.0V
Pin 4 Analog+5V	Analog value 0 - 2.2V	Analog value 2.2 - 2.8V	Analog value 2.8 - 5.0V
Pin 5 +12V	Analog value 0 - 2.2V	Analog value 2.2 - 2.8V	Analog value 2.8 - 5.0V
Pin 7 Tuner+9V	Analog value 0 - 2.2V	Analog value 2.2 - 2.8V	Analog value 2.8 - 5.0V

2. Initial setting on ship

- To gain the initial setting on ship, put the power plug in the socket while pressing DOWN key and UP key together simultaneously, then turn the power ON.

3. Test mode

- To enter the test mode, put the power plug in the socket while pressing EFFECT key and UP key together simultaneously, then turn the power ON.
- Workings of test mode:
 - ① All FLs are turned ON for 3 seconds. (the FLs, which are divided in two groups, are turned ON alternatively)
 - ② A Faster volume UP/DOWN operation can be achieved with the remote controller.
- When the power is turned OFF, the test mode will be released.
- The FL display returns to normal after the three seconds. Then the STANDBY LED is turned ON (flashing ON and OFF for each one second) to show the present status being a test mode.

4. Self-diagnose

- To enter the self-diagnose mode, put the power plug in the socket while pressing SETTING key and UP key together simultaneously, then turn the power ON. With the UP/DOWN key operation, DSP microcomputer, ROM No.of system microcomputer as well as working status of DSP can be displayed for five seconds. While the working status is being displayed, the followings items can be switched with the UP/DOWN key operation.

VERSION of system microcomputer → Local microcomputer CH0 →
 Local microcomputer CH01 → Local microcomputer CH2 →
 Local microcomputer CH3 → Local microcomputer CH4

- When the power is turned OFF, the self-diagnose mode will be released.
- During the self-diagnose mode, the STANDBY LED is turned ON .
 (flashing ON for one second then OFF for three seconds)
- FL transient display will be carried out as follows. When the transient display is not carried out, normal display/workings are carried out.

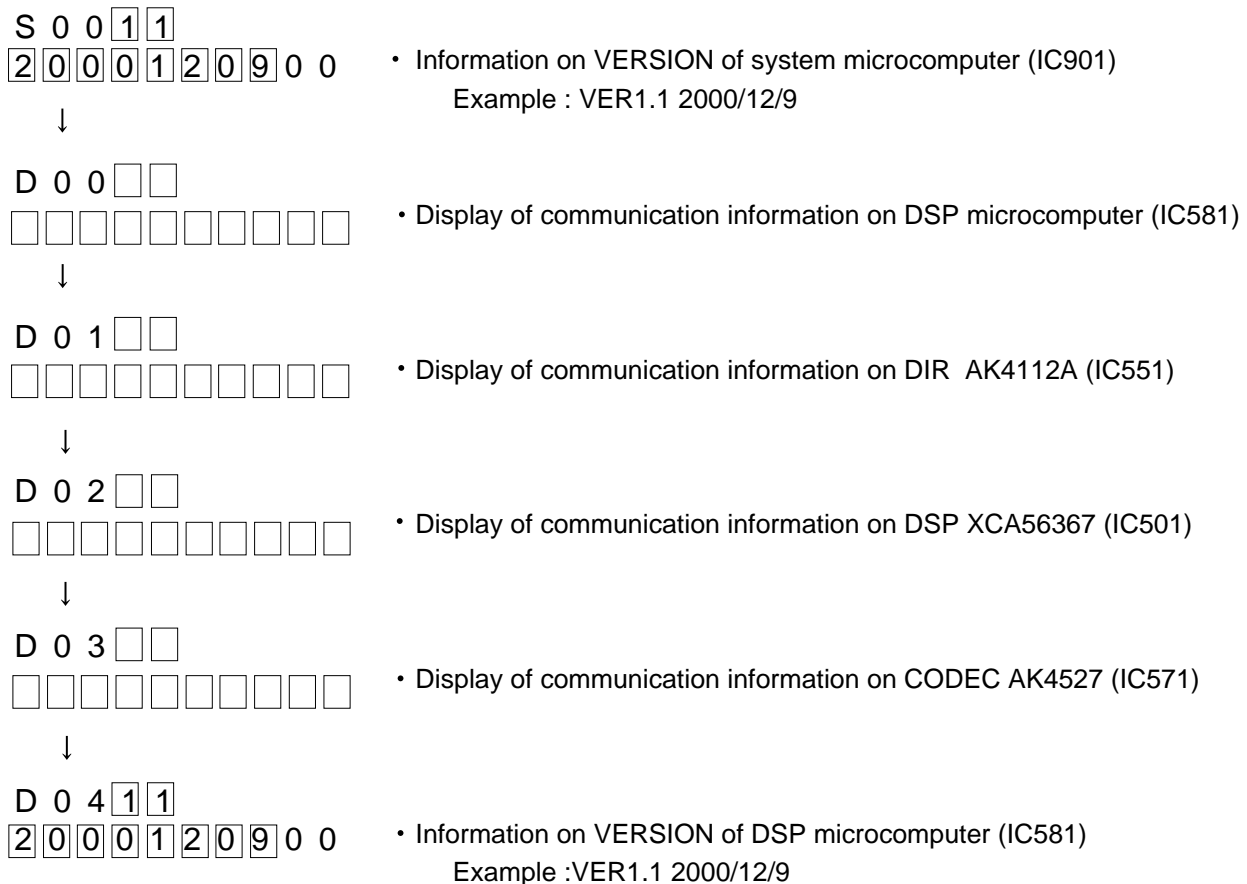
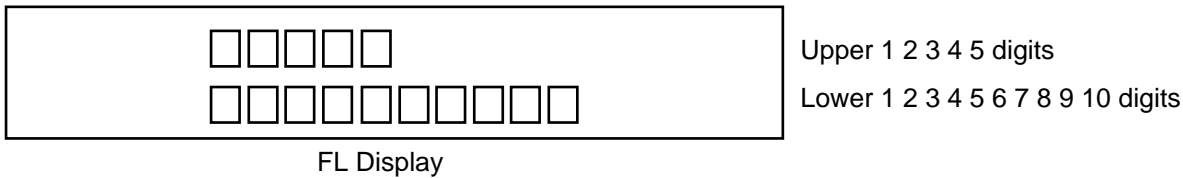

Description of major ICs

■ AK4527 (IC571) : A/D,D/A Converter

1.Pin layout

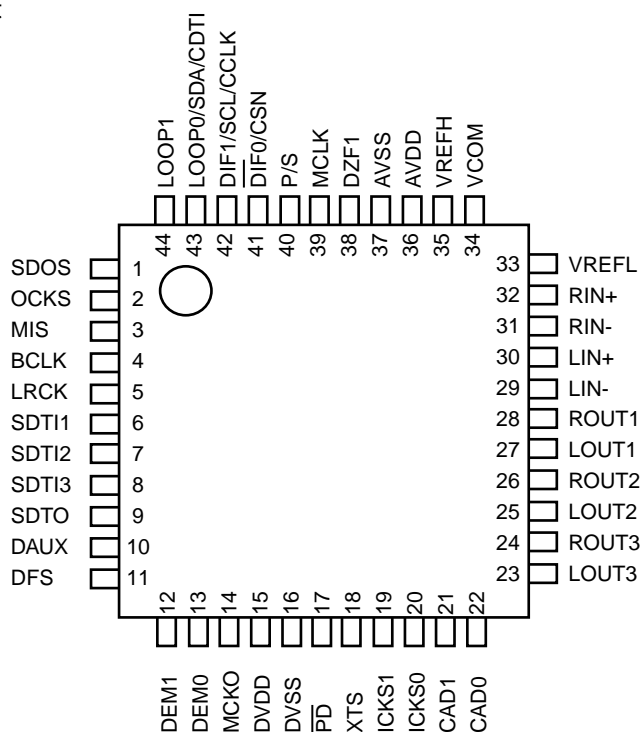

2.Block diagram

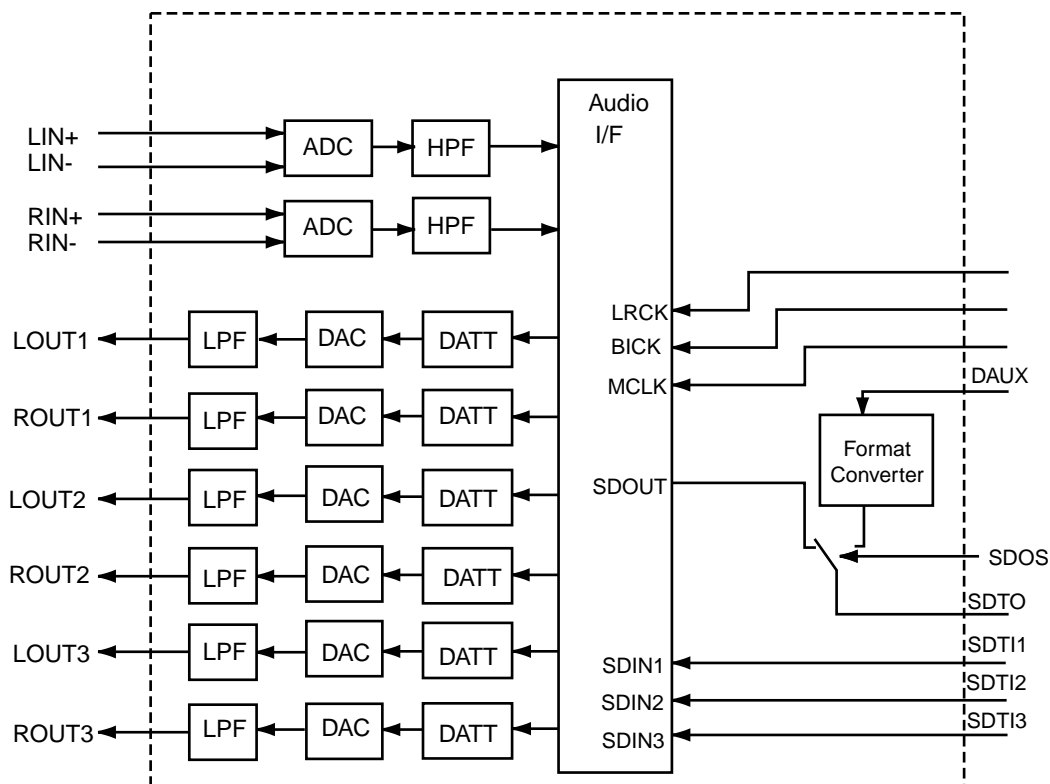

Block Diagram (DIR and AC-3) DSP are external parts)

3. Pin function (1/2)

AK4527(1/2)

No.	Pin name	I/O	Function
1	SDOS	I	SDTO Source select pin "L" : Internal ADC output, "H" : DAUX input ORed with serial control register if P/S="L".
2	OCKS	I	MCKO Clock frequency select pin "L" : MCLK, "H" : MCLK/2. ORed with serial control register if P/S="L".
3	MIS	I	Connect to GND
4	BICK	I	Audio serial data clock pin
5	LRCK	I/O	Input/Output channel clock pin
6	SDTI1	I	DAC1 Audio serial data input pin
7	SDTI2	I	DAC2 Audio serial data input pin
8	SDTI3	I	DAC3 Audio serial data input pin
9	SDTO	O	Audio serial data output pin
10	DAUX	I	AUX Audio serial data input pin
11	DFS	I	Double speed sampling mode pin "L" : Normal speed, "H" : Double speed, the ADC is powered down. ORed with serial control register if P/S="L".
12	DEM1	I	De-emphasis pin ORed with serial control register if P/S="L"
13	DEM0	I	De-emphasis Pin ORed with serial control register if P/S="L"
14	MCKO	O	Master clock output pin
15	DVDD	-	Digital power supply pin
16	DVSS	-	Digital ground pin
17	PD	I	Power-down & Reset pin When "L", the AK4527 is powered-down and the control registers are reset to default state. If the state of CAD0-1 changes, then the AK4527 must be reset by PDN.
18	XTS	I	X'tal oscillator Select/Test mode pin "H" : X'tal Oscillator selected "L" : External clock source selected
19	ICKS1	I	Input clock select 1 pin
20	ICKS0	I	Input clock select 0 pin
21	CAD1	I	Chip address pin Used during the serial control mode.
22	CAD0	I	Chip address pin Used during the serial control mode.
23	LOUT3	O	Lch #3 analog output pin
24	ROUT3	O	Rch #3 analog output pin
25	LOUT2	O	Lch #2 analog output pin
26	ROUT2	O	Rch #2 analog output pin
27	LOUT1	O	Lch #2 analog output pin
28	ROUT1	O	Rch #1 analog output pin
29	LIN-	I	Lch analog negative Input Pin
30	LIN+	I	Lch analog positive Input Pin
31	RIN-	I	Rch analog negative Input Pin
32	RIN+	I	Rch analog positive Input Pin

3.Pin function (2/2)

AK4527(2/2)

No.	Pin Name	I/O	Function
33	VREFL	I	Negative voltage reference Input pin, AVSS
34	VCOM	O	Common voltage output pin,AVDD/2 Large external capacitor around 2.2uF is used to reduce power-supply noise
35	VREFH	I	Positive voltage reference input pin,AVDD
36	AVDD	-	Analog power supply pin
37	AVSS	-	Analog ground pin
38	XTI	I	X'tal input pin
39	XTO	O	X'tal output pin if XTS="H"
	MCKI	I	External master clock input pin if XTS="L"
40	P/S	I	Parallel/Serial select pin "L" : Serial control mode, "H" : Parallel control mode
41	DIF0	I	Audio data interface format pin in parallel mode
	CS	I	Chip select pin in serial mode
42	DIF1	I	Audio data interface format pin in parallel mode
	CCLK	I	Control data clock pin in serial mode
43	LOOP0	I	Loop back mode pin in parallel mode Enables digital loop-back from ADC to 3 DACs.
	CDTI	I	Control data input pin in serial mode
44	LOOP1	I	Loop back mode pin in parallel mode Enable all 3 DAC channels to be input from SDTII.
	CDTO	O	Control data output pin in serial mode

■ BA15218F(IC303, IC304, IC372, IC385, IC386) : OP AMP.

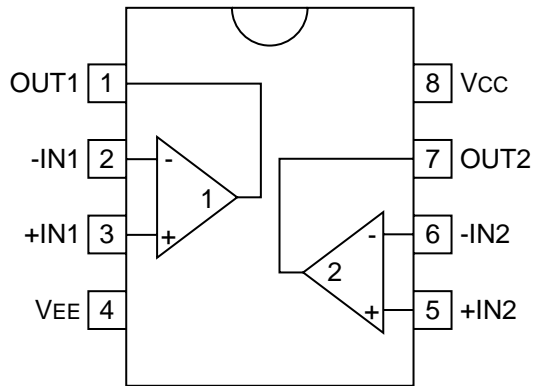

■ BA7625 (IC201, IC242) : Video selector

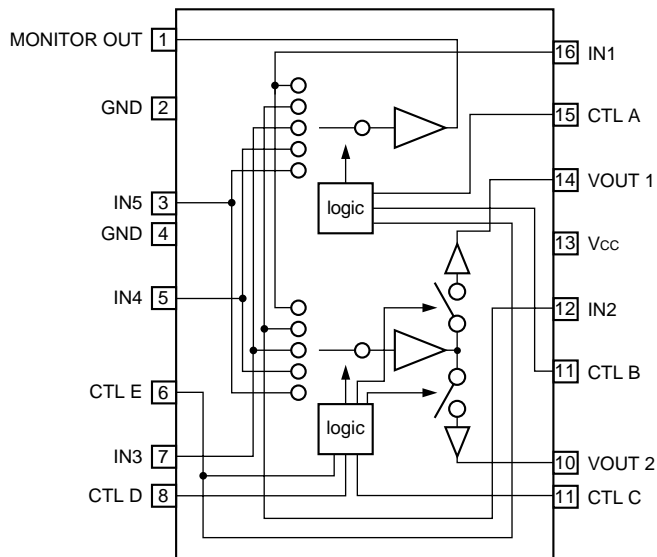

A	B	E	MONITOR OUT
L	L	*	IN1
H	L	*	IN2
L	H	*	IN3
H	H	L	IN4
H	H	H	IN5

C	D	E	VOUT1
L	L	*	--
H	L	*	IN2
L	H	*	IN3
H	H	L	IN4
H	H	H	IN5

C	D	E	VOUT2
L	L	*	IN1
H	L	*	--
L	H	*	IN3
H	H	L	IN4
H	H	H	IN5

■ BA7626 (IC241) : Video selector

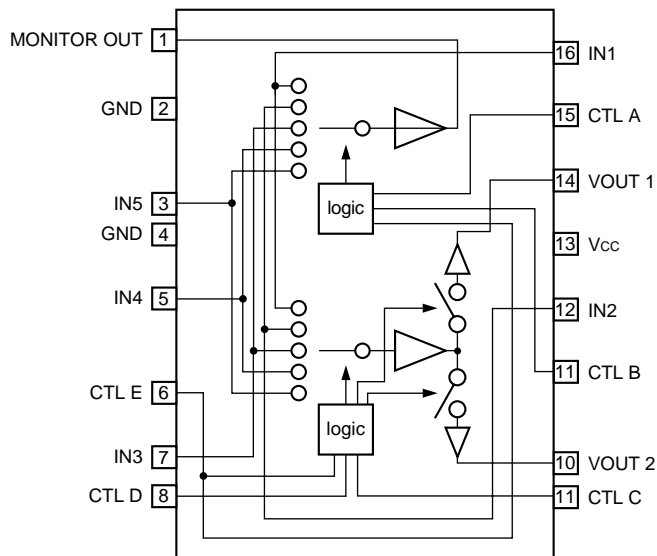

A	B	E	MONITOR OUT
L	L	*	IN1
H	L	*	IN2
L	H	*	IN3
H	H	L	IN4
H	H	H	IN5

C	D	E	VOUT1
L	L	*	--
H	L	*	IN2
L	H	*	IN3
H	H	L	IN4
H	H	H	IN5

C	D	E	VOUT2
L	L	*	IN1
H	L	*	--
L	H	*	IN3
H	H	L	IN4
H	H	H	IN5

■ BU2092(IC402):PORT EXPANDER

1. Terminal Layout

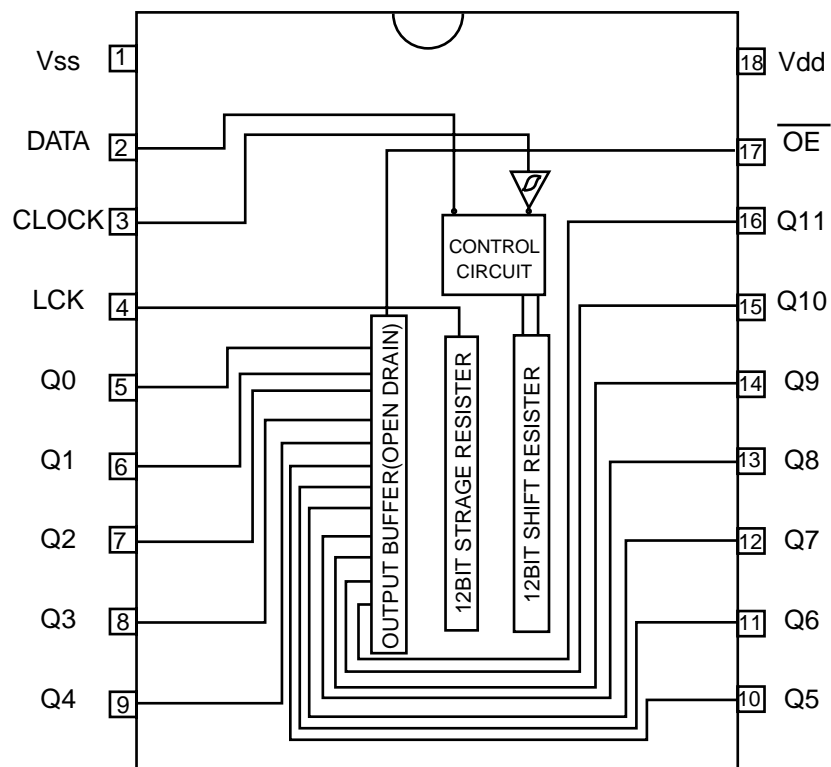

2.Pin Function

Pin No.	Symbol	I/O	Function						
1	Vss	-	Connect to GND						
2	DATA	I	Serial Data input						
3	CLOCK	I	Shift Clock of Data						
4	LCK	I	Latch Clock of Data						
5~16	Q0~Q11	O	Parallel Data Output <table border="1" style="margin-left: 20px;"> <tr> <td>Latch Data</td> <td>L</td> <td>H</td> </tr> <tr> <td>OUTPUT</td> <td>ON</td> <td>OFF</td> </tr> </table>	Latch Data	L	H	OUTPUT	ON	OFF
Latch Data	L	H							
OUTPUT	ON	OFF							
17	$\overline{\text{OE}}$	I	Output Enable						
18	Vdd	-	Power Supply						

■ MB90088 (IC203) : On screen display controller

1. Terminal Layout

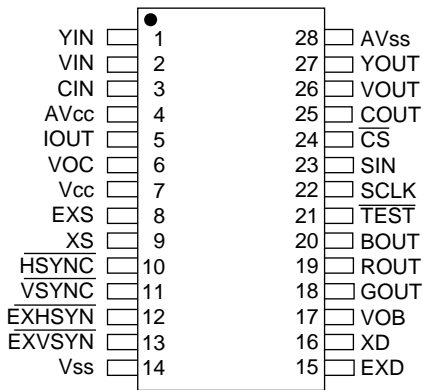

2. Block Diagram

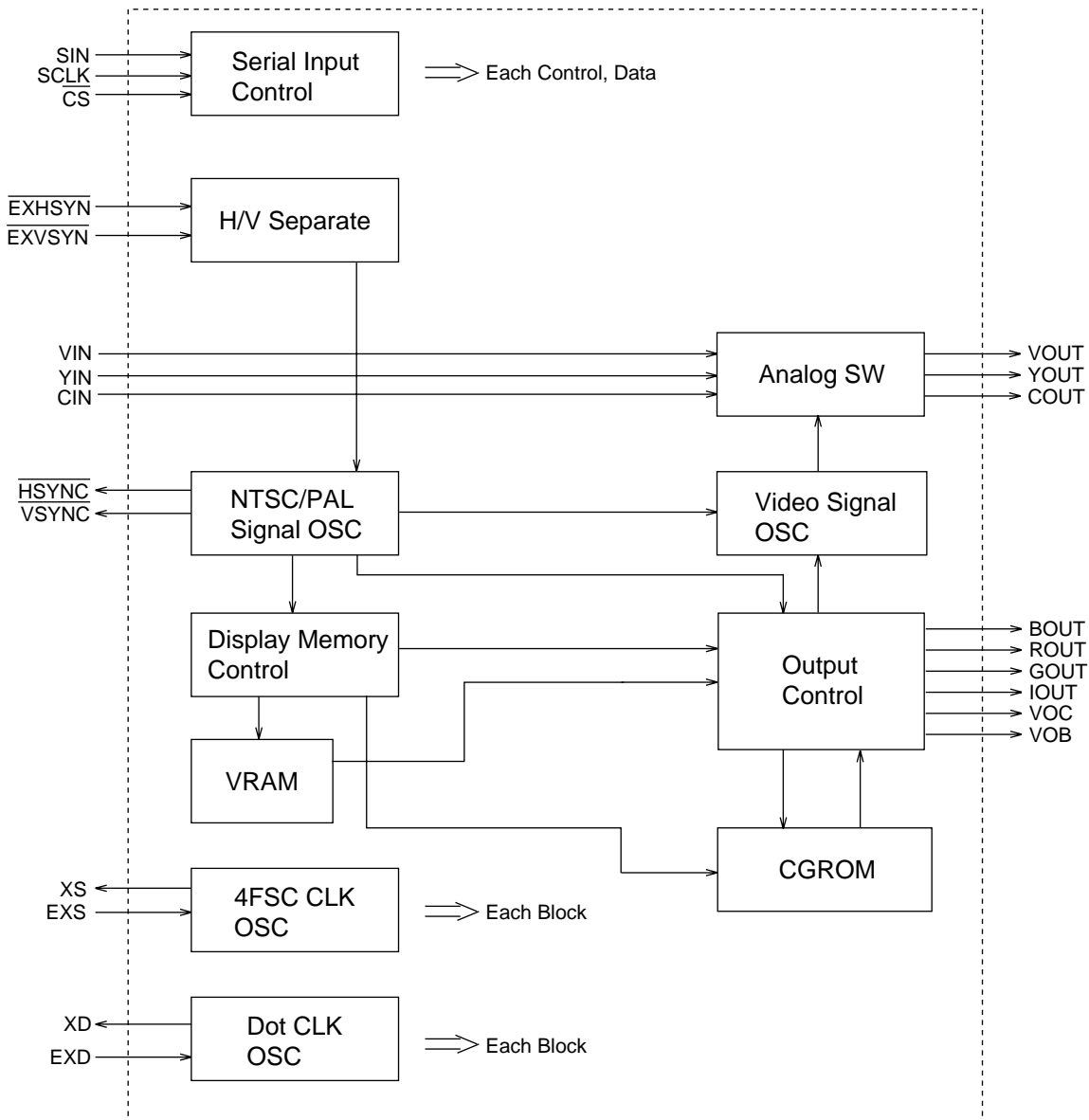

3.Functions

pin no	Symbol	I/O	Function
1	YIN	I	Lux signal Input terminal for Superinpause indication
2	VIN	I	Composite video signal input terminal for Superinpause indication
3	CIN	I	Contrast signal input terminal for Superinpause indication
4	AVcc	-	Analog power supply terminal
5	IOUT	O	Color (Lux) signal output terminal
6	VOC	O	Character output terminal
7	Vcc	-	Power supply terminal
8	EXS	I	Clock generater outside circuit terminal for color burst
9	XS	O	
10	$\overline{\text{HSYNC}}$	O	Horizontal signal output terminal
11	$\overline{\text{VSYNC}}$	O	Vertical signal output terminal
12	$\overline{\text{EXHSYN}}$	I	EXT horizontal signal input terminal
13	$\overline{\text{EXVSYN}}$	I	EXT vertical signal input terminal
14	Vss	-	GND
15	EXD	I	Dot clock generater outside circuit signal terminal for indication
16	XD	O	
17	VOB	O	Character & background signal output terminal
18	GOUT	O	Color signal (Green, Red, Blue)
19	ROUT		
20	BOUT		
21	$\overline{\text{TEST}}$	I	Test signal input terminal
22	SCLK	I	Shift clock input terminal for serial transmission
23	SIN	I	Serial data input terminal
24	$\overline{\text{CS}}$	I	Chip select terminal
25	COUT	O	Contrast signal output terminal
26	VOUT	O	Composite video signal output terminal
27	YOUT	O	Lux signal output terminal
28	AVss	-	Analog GND terminal

■ MAX4018ESD (IC390) : OP AMP.

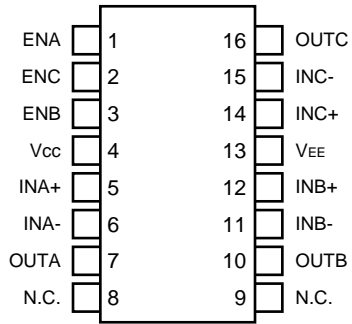

■ NJM2285V-W(IC202) : 2-INPUT 3CHANNEL VIDEO SWITCH

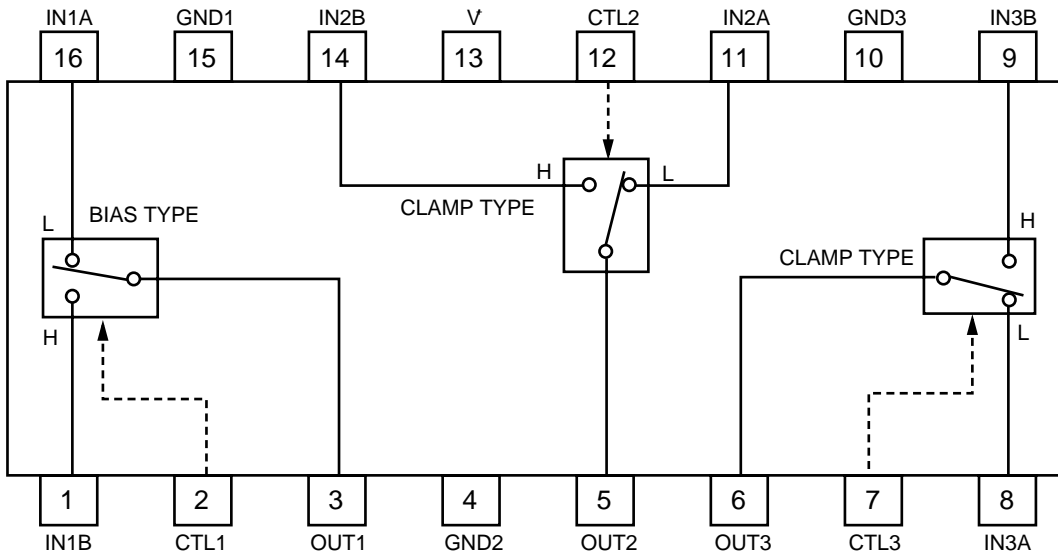

■ NJM4580D (IC301) : LPF, Mic and H.phone Amp.

1.Terminal layout

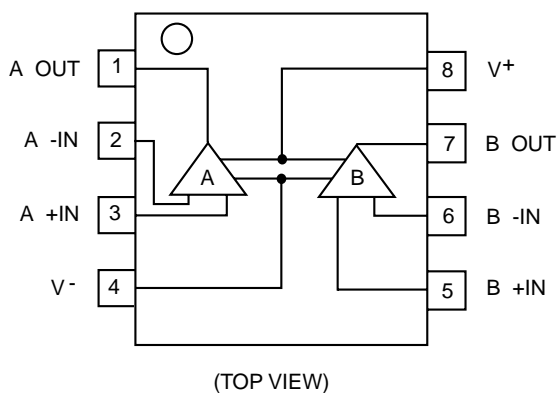

2.Block diagram

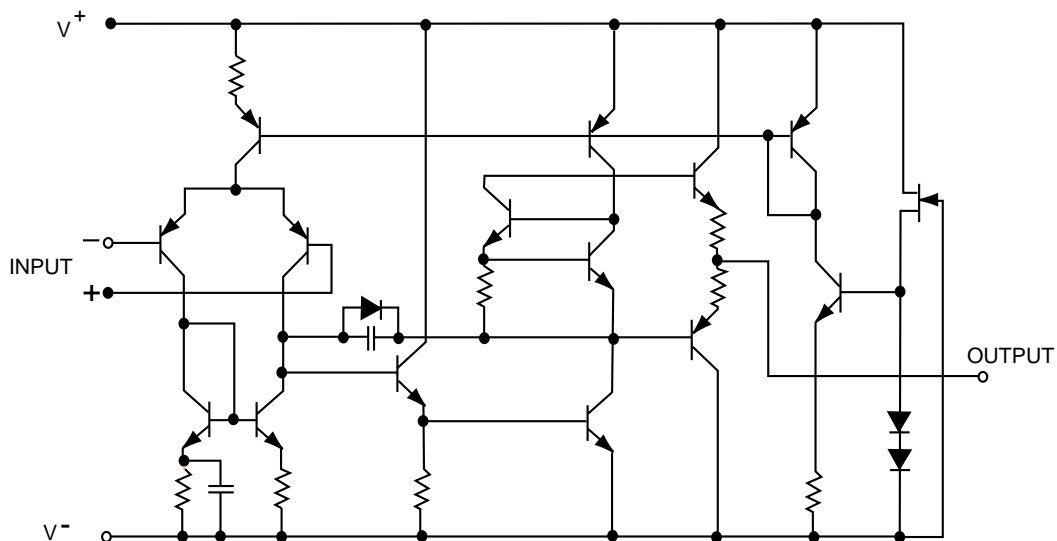

■ NJU7241F33(IC411) : VOLTAGE REGULATOR

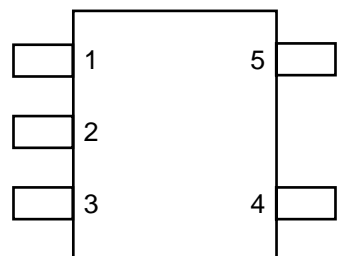

- PIN FUNCTION
- 1. GND
 - 2. V_{IN}
 - 3. V_{OUT}
 - 4. +NC
 - 5. STB

■ PCM2702E-X (IC410) : DIGITAL / ANALOG CONVERTER

1.Pin layout

1	XTI	XTO	28
2	VDDC	VCCP	27
3	DGND	AGNDP	26
4	VDD	VCCL	25
5	DGND	AGNDL	24
6	D+	VOUTL	23
7	D-	VCC	22
8	VBUS	VCOM	21
9	DGND	AGND	20
10	PLYBCK	VOUTR	19
11	SSPND	AGNDR	18
12	ZERO	VCCR	17
13	TEST3	TEST0	16
14	TEST2	TEST1	15

2. Block diagram

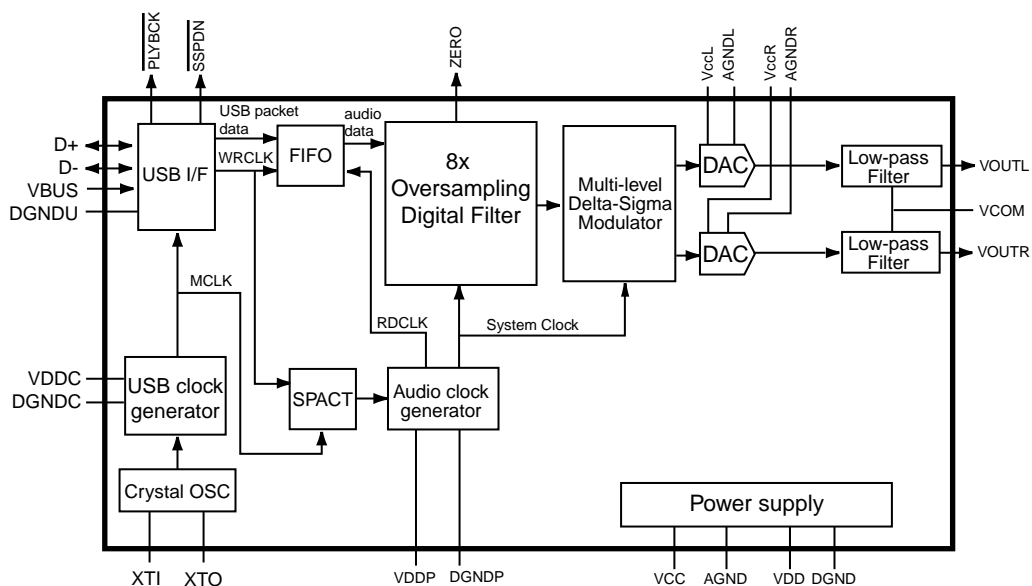

3.Pin function

PIN	Symbol	I/O	Function
1	XTI	IN	Crystal Oscillator Input. (1)
2	VDDC	-	Digital Power Supply for Clock Generator, +3.3V.
3	DGND	-	Digital Ground for Clock Generator.
4	VDD	-	Digital Power Supply, +3.3V.
5	DGND	-	Digital Ground.
6	D+	I/O	USB Differential Input/Output Plus.
7	D-	I/O	USB Differential Input/Output Minus.
8	VBUS	IN	USB Bus Power (This pin NEVER consumes the USB bus power). (2)
9	DGNDU	-	Digital Ground for USB Transceiver.
10	PLYBCK	OUT	Playback flag, active LOW. (LOW: playback, HIGH: idle).
11	SSPND	OUT	Suspend flag, active LOW. (LOW: suspend, HIGH: operational).
12	ZERO	OUT	Zero flag, (LOW: Normal, HIGH: ZERO).
13	TEST3	IN	Test pin 3. Connect to digital ground. (2)
14	TEST2	IN	Test pin 2. Connect to digital ground. (2)
15	TEST1	IN	Test pin 1. Connect to digital ground. (2)
16	TEST0	IN	Test pin 0. Connect to digital ground. (2)
17	VCCR	-	Analog Supply for R-channel, +5V.
18	AGNDR	-	Analog Ground for R-channel.
19	VOUTR	OUT	Analog Output for R-channel.
20	AGND	-	Analog Ground.
21	VCOM	-	Common for DAC.
22	VCC	-	Analog Supply, +5V.
23	VOUTL	OUT	Analog output for L-channel.
24	AGNDL	-	Analog Ground for L-channel.
25	VCCL	-	Analog Supply for L-channel, +5V.
26	AGNDP	-	Analog Ground for PLL.
27	VCCP	-	Analog Supply for PLL, +5V.
28	XTO	OUT	Crystal Oscillator Output.

Note:

(1) 3.3V tolerant.

(2) Schmitt trigger input with internal pull-down, 5V tolerant.

■ TC9162AN (IC380) : ANALOG SWITCH

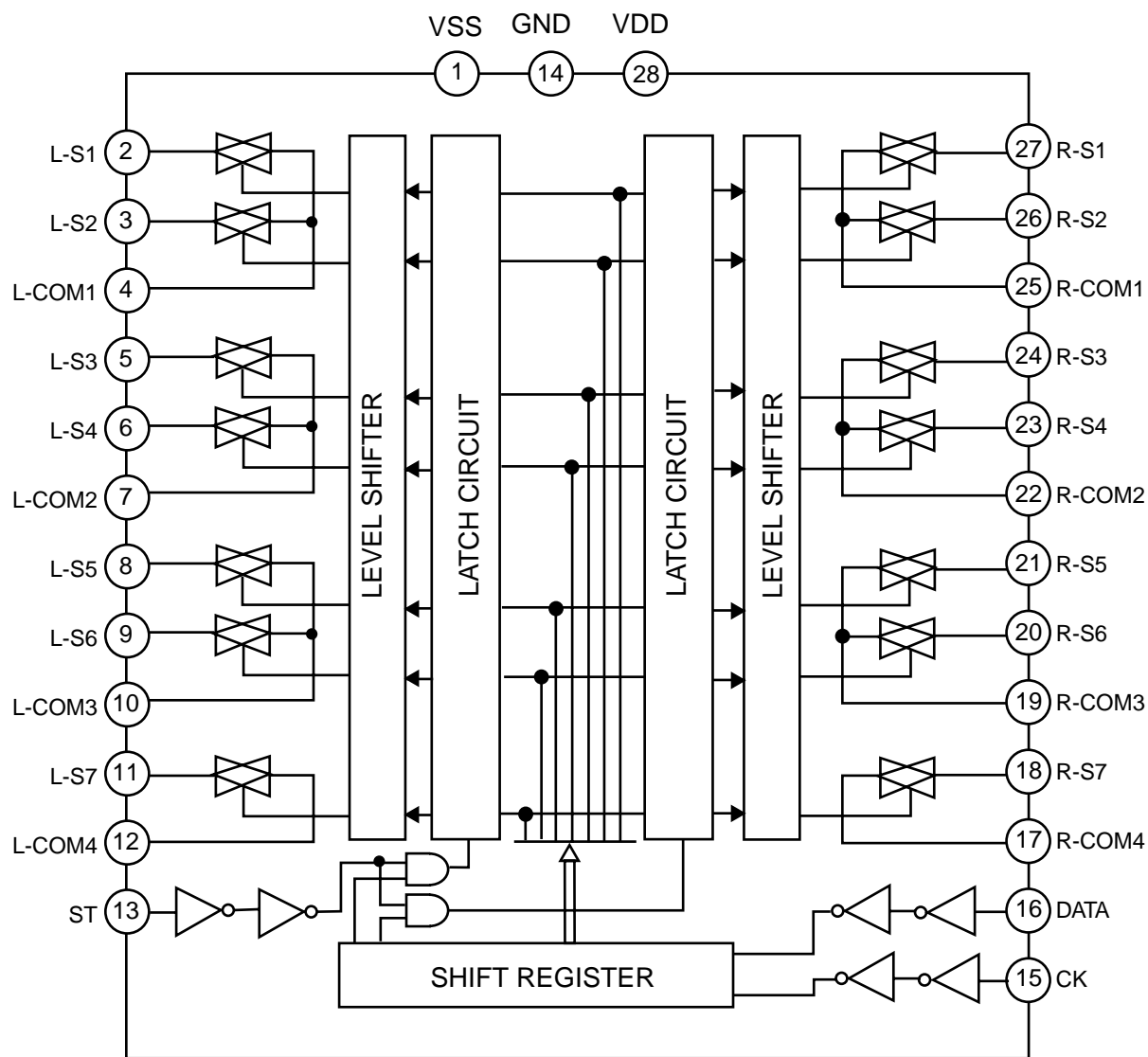
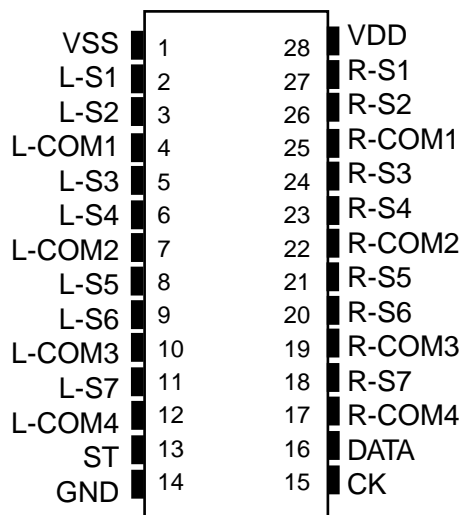

■ TC9163AF-X (IC371) : ANALOG SWITCH

VSS	1	28	VDD
L-S1	2	27	R-S1
L-S2	3	26	R-S2
L-S3	4	25	R-S3
L-COM1	5	24	R-COM1
L-S4	6	23	R-S4
L-S5	7	22	R-S5
L-S6	8	21	R-S6
L-COM2	9	20	R-COM2
L-S7	10	19	R-S7
L-S8	11	18	R-S8
L-COM3	12	17	R-COM3
ST	13	16	DATA
GND	14	15	CK

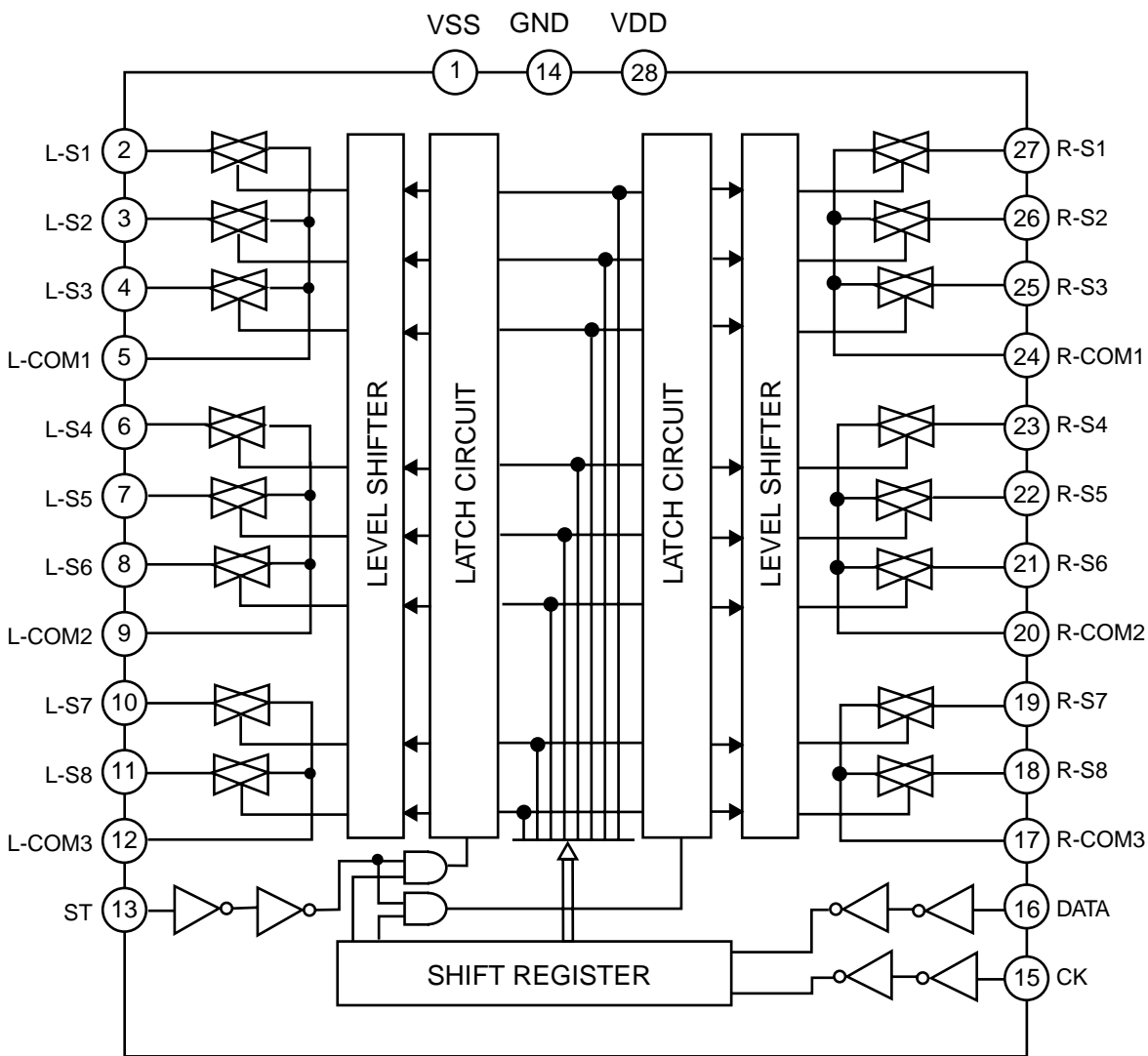

■ TC9164AF-X (IC302) : ANALOG SWITCH

VSS	1	28	VDD
L-S1	2	27	R-S1
L-S2	3	26	R-S2
L-S3	4	25	R-S3
L-S4	5	24	R-S4
L-COM1	6	23	R-COM1
L-S5	7	22	R-S5
L-S6	8	21	R-S6
L-COM2	9	20	R-COM2
L-S7	10	19	R-S7
L-S8	11	18	R-S8
L-COM3	12	17	R-COM3
ST	13	16	DATA
GND	14	15	CK

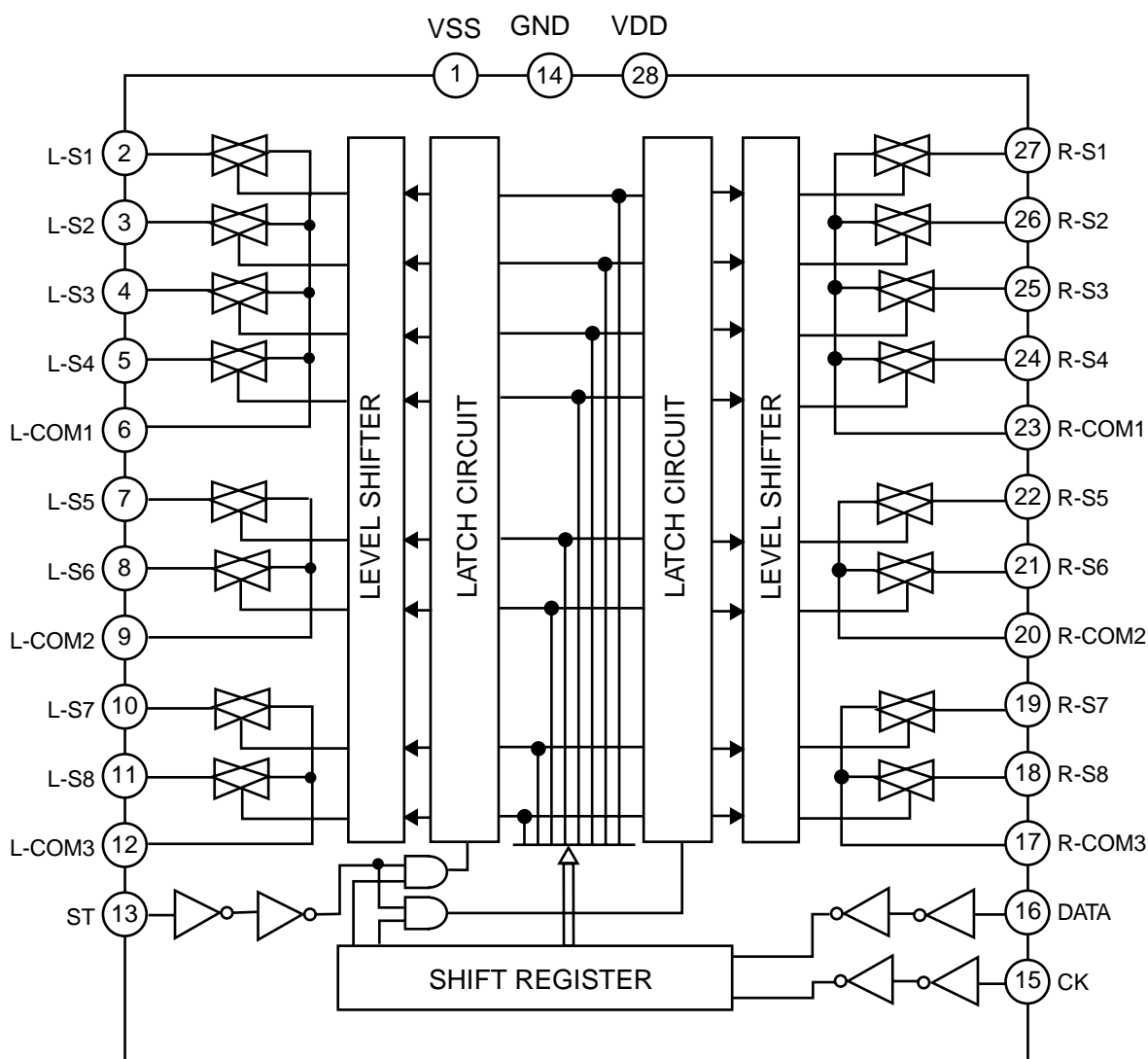

■ TC9459F (IC381, IC382, IC383) : Electronic volume control

1. Terminal layout

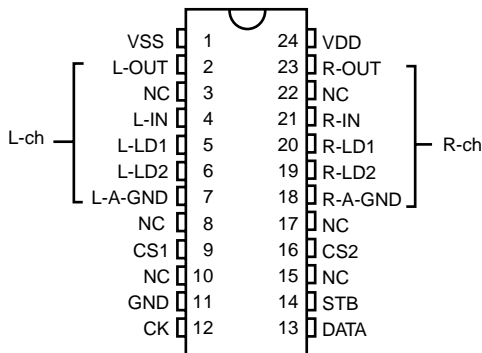

2. Block diagram

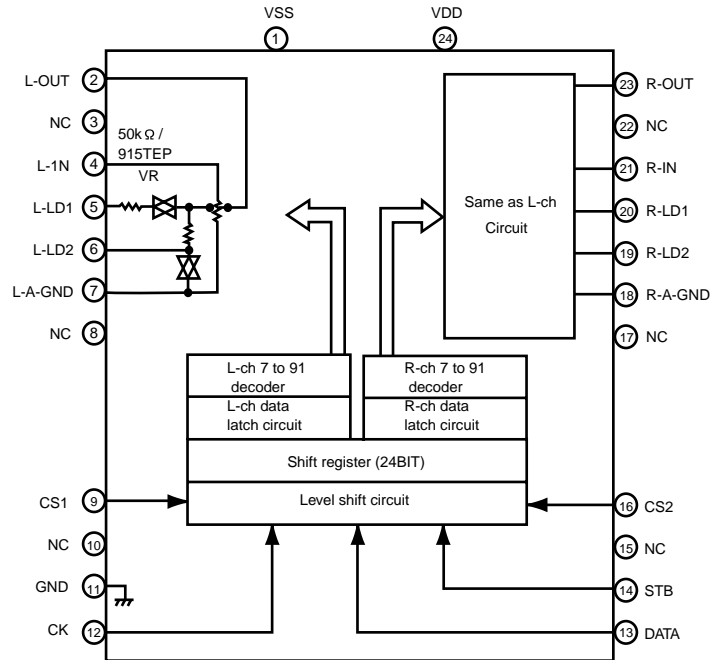

3. Pin function

Pin No.	Symbol	Function	Pin No.	Symbol	Function
1	VSS	Negative power supply pin	13	DATA	Data input pin
2	L-OUT	Volume output pin	14	STB	Strobe input pin
3	NC	No connection	15	NC	No connection
4	NC	No connection	16	CS2	Chip select input pin
5	L-LD1	Loudness tap output pin	17	NC	No connection
6	L-LD2	Loudness tap output pin	18	R-A-GND	Analog GND pin
7	L-A-GND	Analog GND pin	19	R-LD2	Loudness tap output pin
8	NC	No connection	20	R-LD1	Loudness tap output pin
9	CS1	Chip select input pin	21	R-IN	Volume input pin
10	NC	No connection	22	NC	No connection
11	NC	No connection	23	R-OUT	Volume output pin
12	CK	Clock input pin	24	VDD	Positive power supply pin

■ PQ3DZ53 (IC583) : Regulator IC

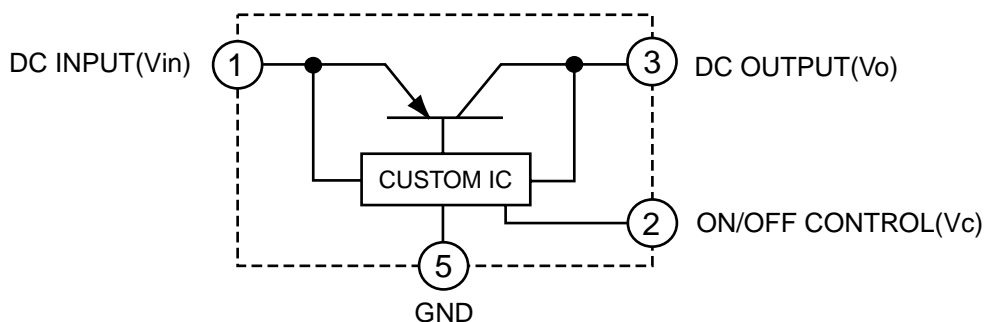

■ TC74HC4053AF (IC388, IC389) : MULTIPLEXER

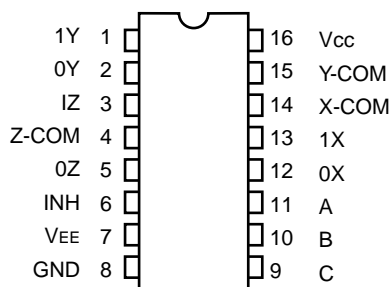

CONTROL INPUTS			
INHIBIT	C	B	A
L	L	L	K
L	L	L	H
L	L	H	K
L	L	H	H
L	H	L	K
L	H	L	H
L	H	H	K
L	H	H	H
H	X	X	X

X: Don't Care.

■ W24L010AJ-12 (IC511) : CMOS STATIC RAM

1. Pin layout

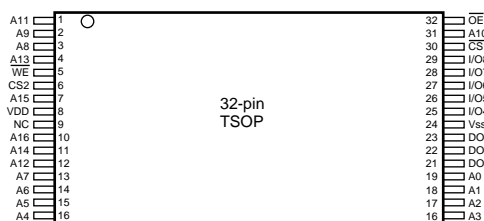
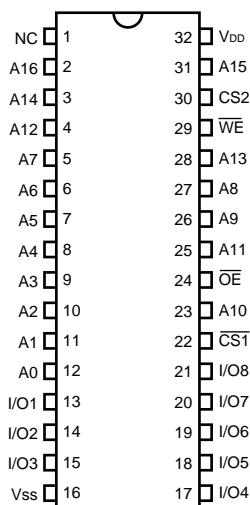

2. Block diagram

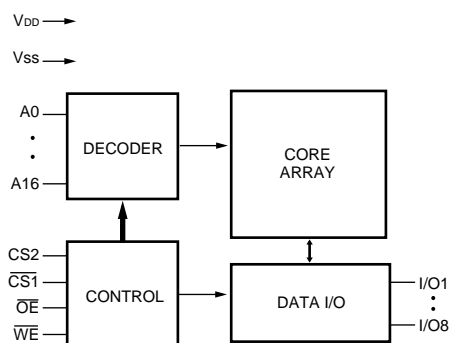

3. Pin function

SYMBOL	DESCRIPTION
A0 - A16	Address Input
I/O1 - I/O8	Data Input/Output
CS1, CS2	Chip Select Inputs
WE	Write Enable Input
OE	Output Enable Input
VDD	Power Supply
Vss	Ground
NC	No Connection

■ UPD784215AGC132(IC581) : UNIT CPU

1.Pin layout

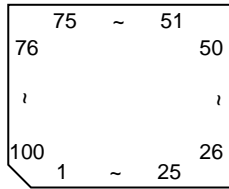

2.Pin function

Pin No.	Symbol	I/O	Function
1~8		-	Non connect
9	VDD	-	Power supply terminal
10	X2	-	Connecting the crystal oscillator for system main clock
11	X1		Connecting the crystal oscillator for system main clock
12	VSS	-	Connect to GND
13	XT2	-	Connecting the crystal oscillator for system sub clock
14	XT1		Connect VSS
15	RESET		System reset signal input
16	AUTO		Output of DSP to general-purpose port
17	ERR		Output of DSP to general-purpose port
18	Fz96k		Output of DSP to general-purpose port
19~22	P03~P06		Output of DSP to general-purpose port
23	AVDD	-	Power supply terminal
24	AV REF0	-	Connect to GND
25~32	P10~P17	-	Connect to GND
33	AVSS	-	Connect to GND
34,35	P130, P131	O	Non connect
36	AV REF1	-	Power supply terminal
37,38	RX, TX	O	Not use
39		O	Non connect
40	DSPCOM		Communication port from IC901
41	DSPSTS	O	Status communication port to IC901
42	DSPCLK		Clock input from IC901
43	DSPRDY		Ready signal input from IC901
44		O	Non connect
45,46	MIDIO_IN/OUT	I/O	Interface I/O terminal with microcomputer
47	MICK	O	Interface I/O terminal with microcomputer of clock signal
48	HREQ		HREQ
49	SS	O	System slave select
50,51		-	Non connect
52	DSP_RST	O	Reset signal output of DSP
53		-	Non connect
54	D_CS	O	Chip setselct output
55		-	Non connect
56	PD/ DIR	O	Reset signal output
57~63		-	Non connect
64,65	CDTI/CDTO	O/I	Interface I/O terminal with microcomputer
66	CCLK	O	Interface I/O terminal with microcomputer of clock signal
67	CS	O	CS
68~70		-	Non connect
71	PD	O	Reset signal output
72	GND	-	Connect to GND
73~75		-	Non connect
76	EQ	O	EQ
77	CTR TONE	O	CENTER TONE
78	3D	O	3D-Phonic
79,80		-	Non connect
81	VDD	-	Power supply
82,83		-	Non connect
84	ANA_TT	O	Analog./T.TONE
85	LEF_MIX	O	Select 1
86	LEF_OUT	O	Select 2
87	MIX_OUT	O	Select 3
88	S_MUTE	O	S.MUTE
89~93		-	Non connect
94	TEST	-	Test terminal
95~100		-	Non connect

RX-8010VBK

JVC

VICTOR COMPANY OF JAPAN, LIMITED

AUDIO & COMMUNICATION BUSINESS DIVISION

PERSONAL & MOBILE NETWORK BUSINESS UNIT. 10-1,1chome,Ohwatari-machi,Maebashi-city,371-8543,Japan

(No.20921)



Printed in Japan
200103(V)

Block diagrams

■ Signal I/O block section

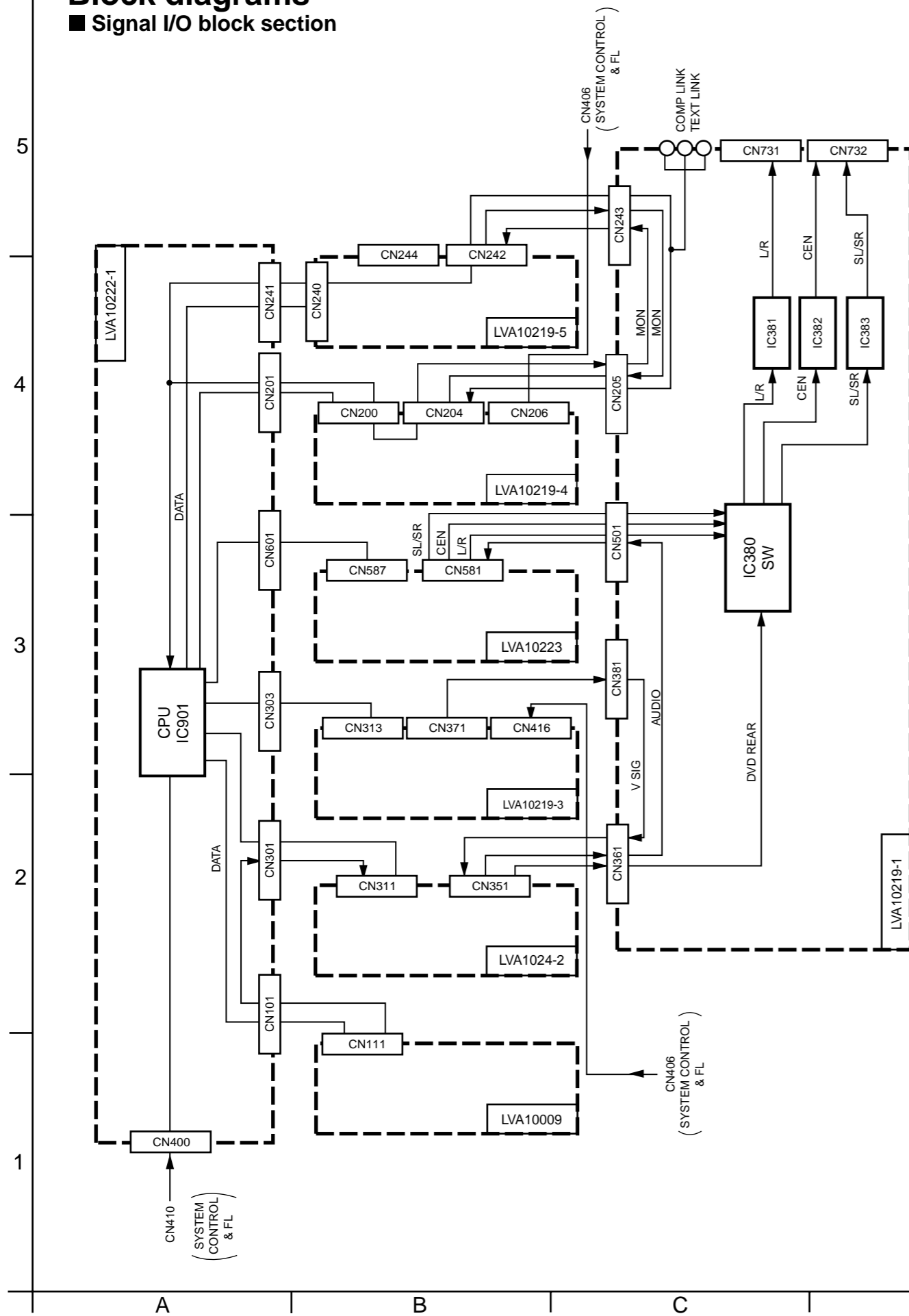

■ Main section

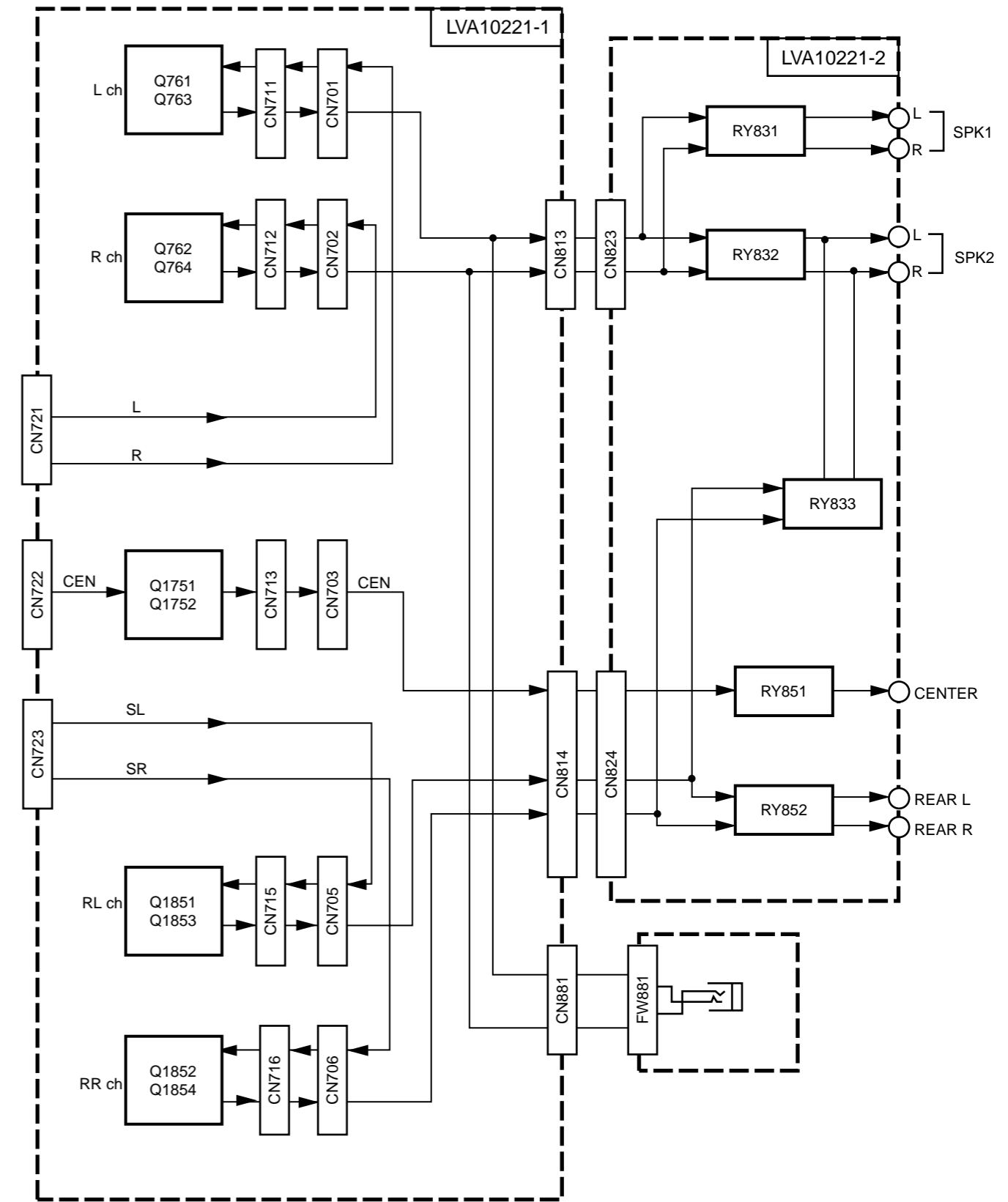

■ Video section

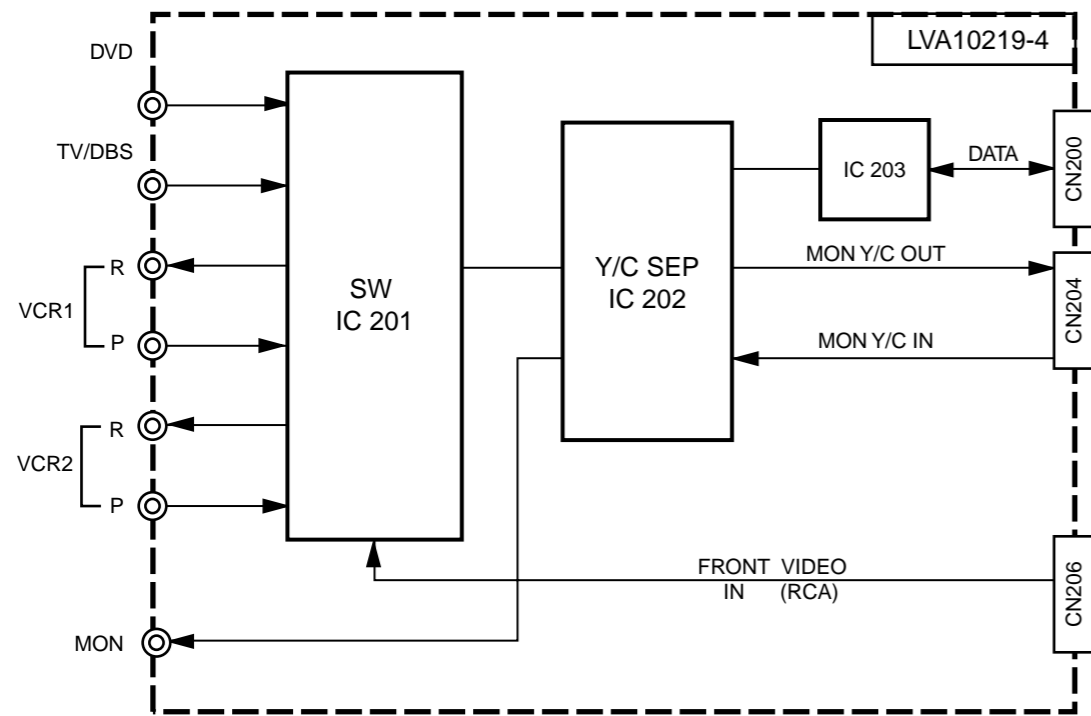

■ Video input section

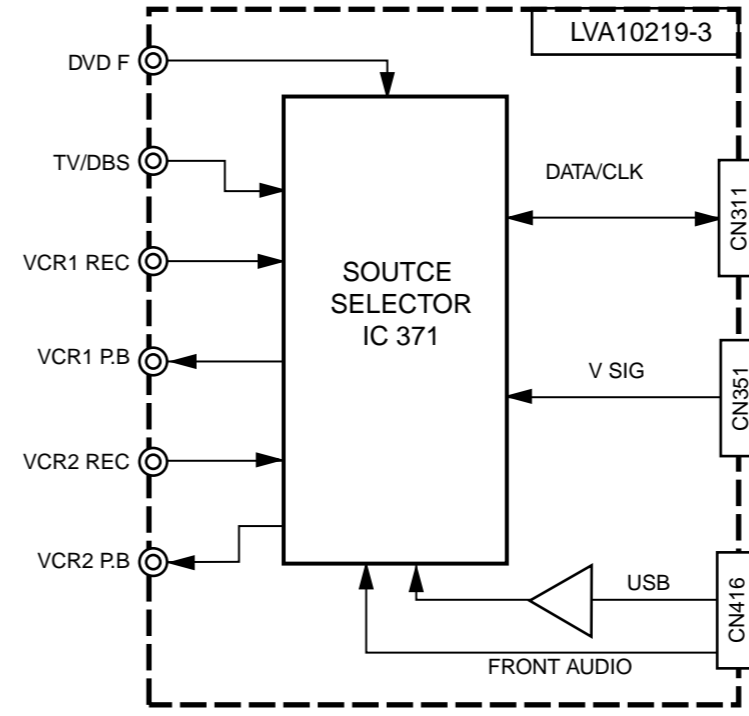

■ S Video section

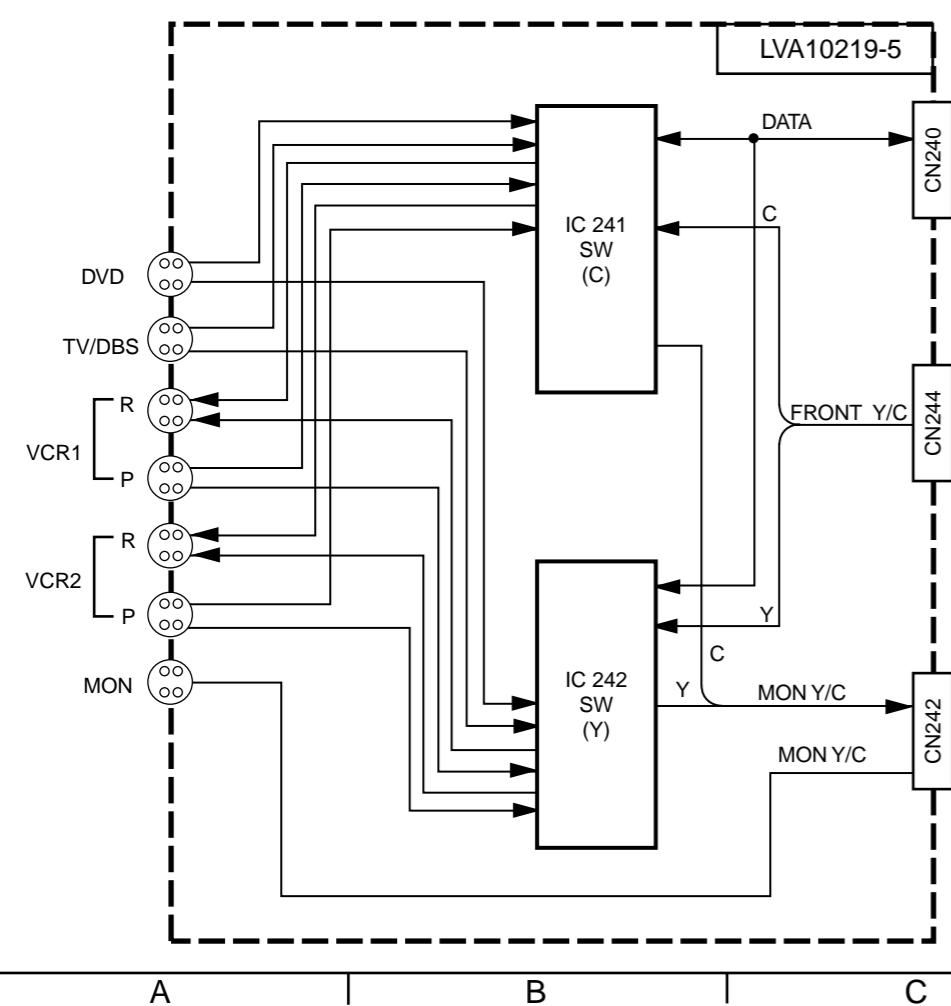

■ DSP section

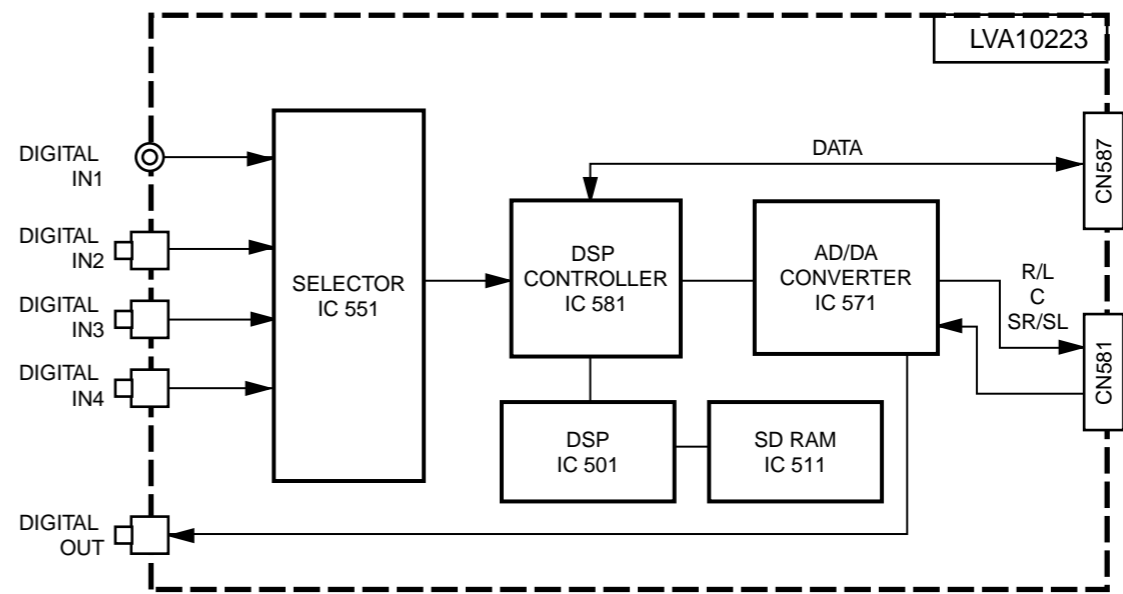

5
4
3
2
1

A B C 2-2 D E F G H

■ Tuner section

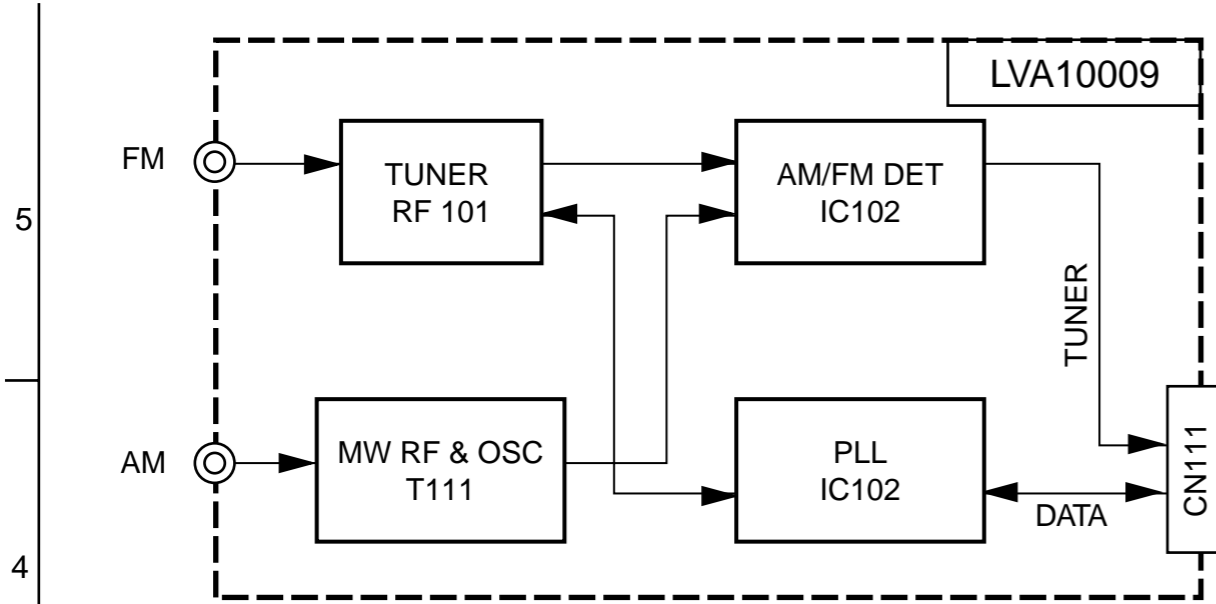

■ System control & FL section

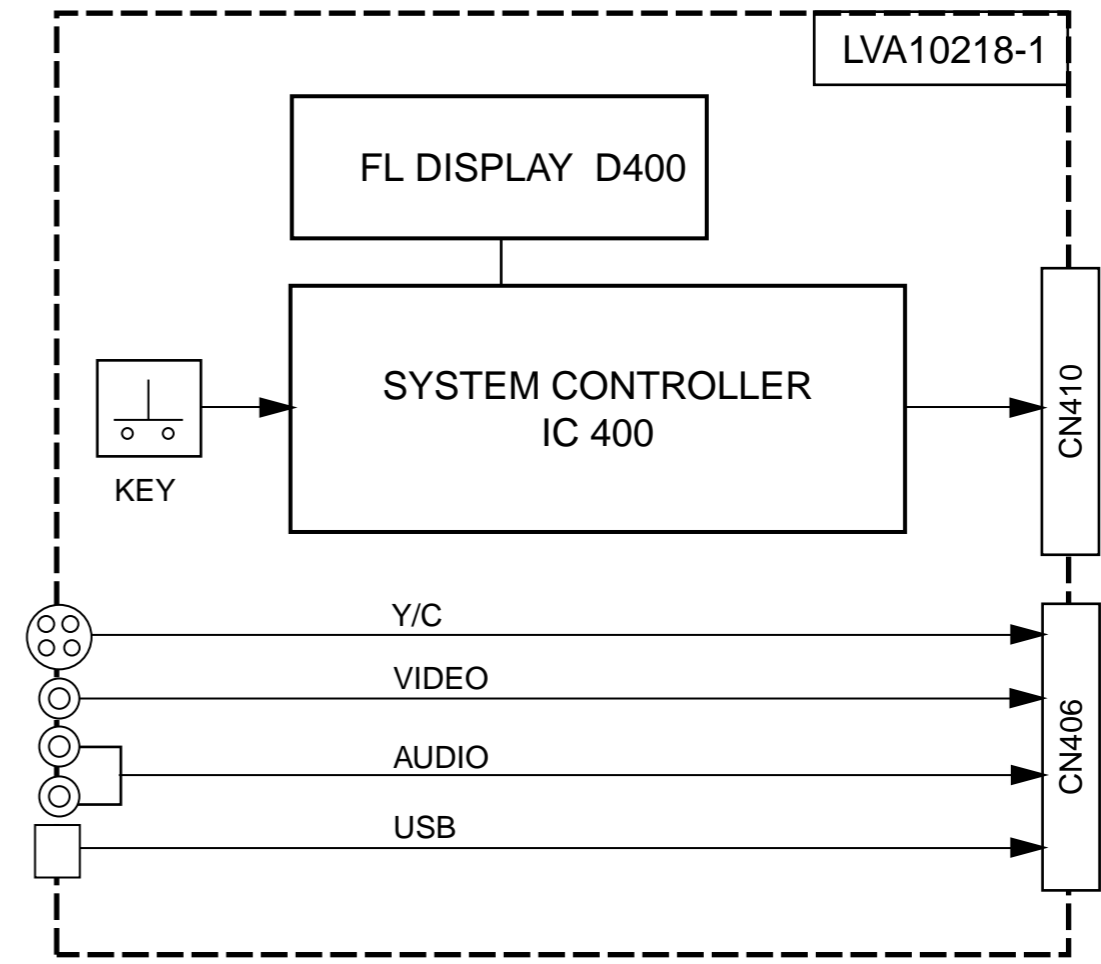

■ Audio input section

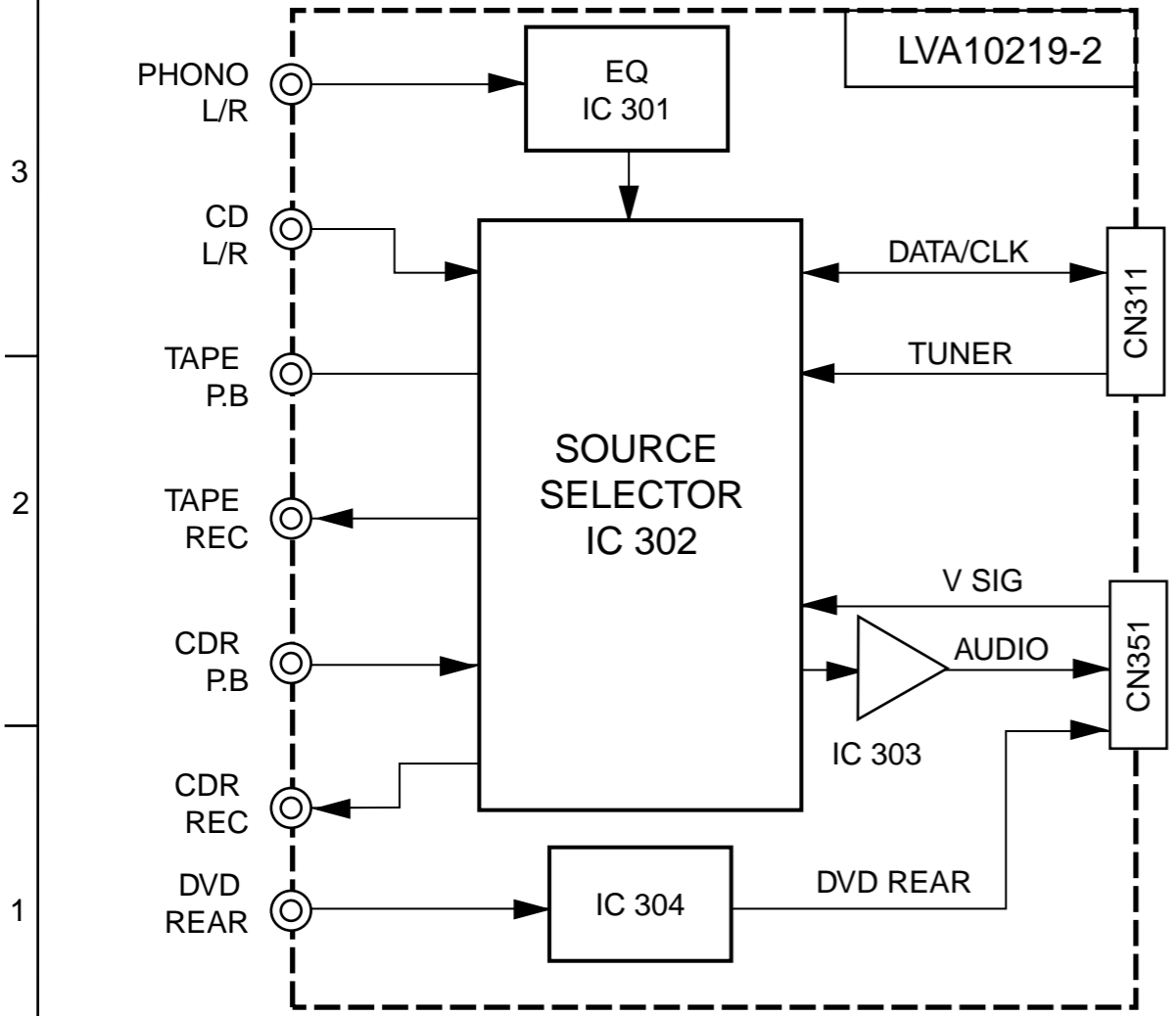

Standard schematic diagrams

Power supply section

5

4

3

2

1

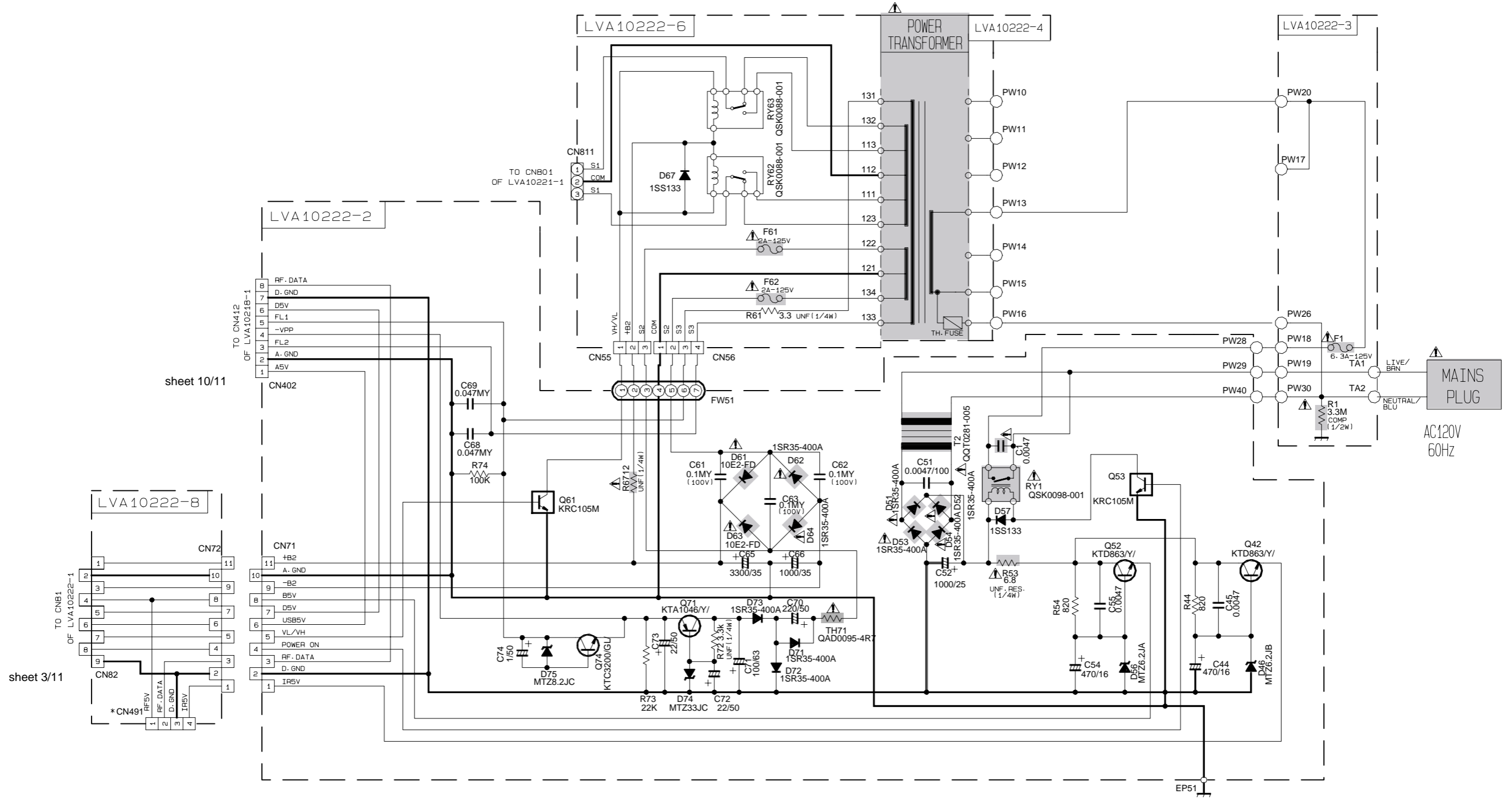

sheet 10/11

sheet 3/11

SHEET NUMBER	CIRCUIT DESCRIPTION
1/11	POWER SUPPLY
2/11	MAIN
3/11	AUDIO
4/11	AUDIO SIGNAL INPUT
5/11	VIDEO SIGNAL INPUT
6/11	AUDIO AMP (FRONT CHANNEL)
7/11	AUDIO AMP (CENTER, REAR CHANNEL)
8/11	DSP
9/11	DVD
10/11	SYSTEM CONTROL
11/11	TUNER

▲ Parts are safety assurance parts. When replacing those parts make sure to use the specified one.

A B C 2-4 D E F G H

Audio section

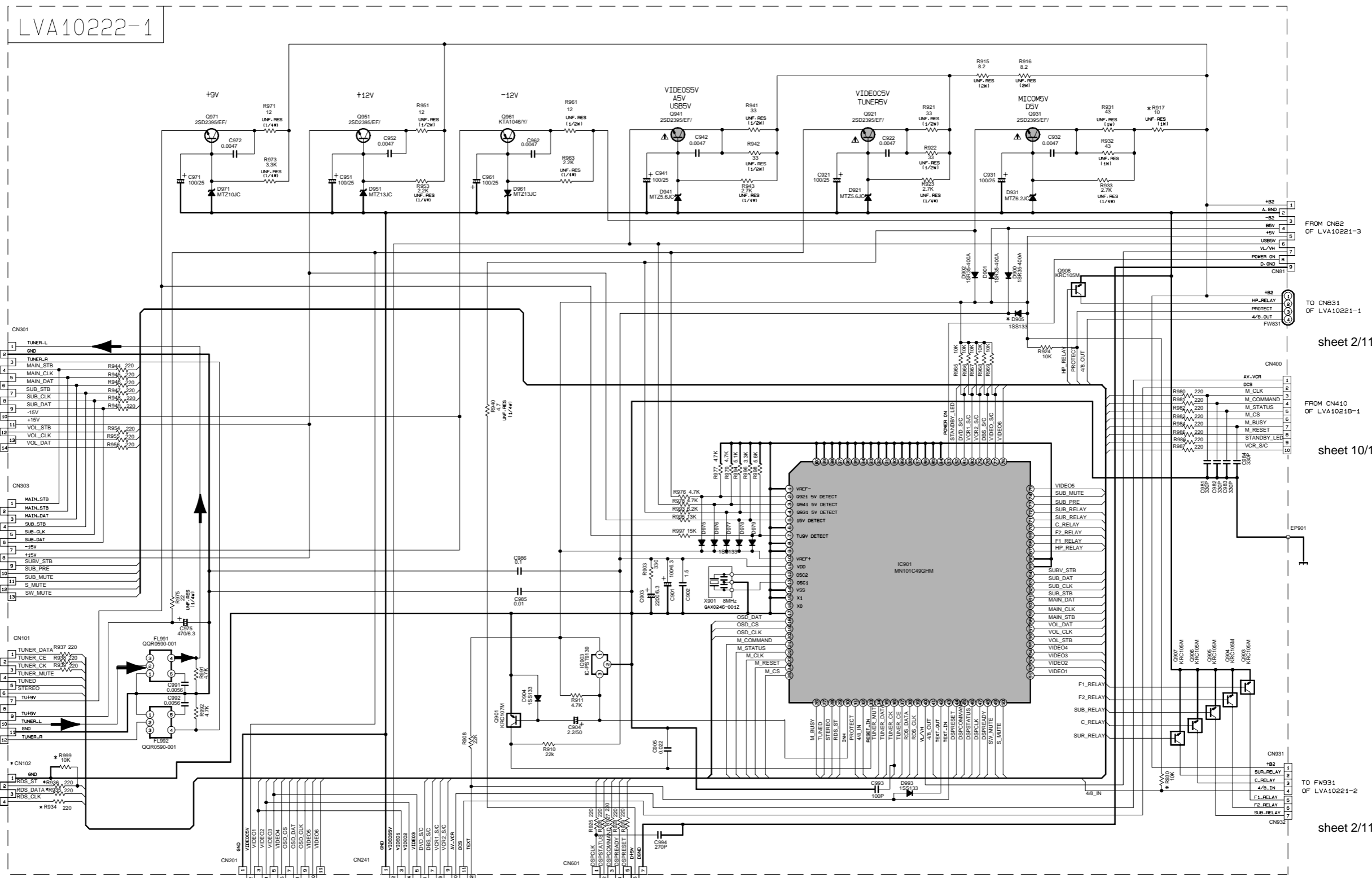

5
4
3
2
1

TO CN311
OF LVA10219-2
sheet 4/11

TO CN313
OF LVA10219-3
sheet 4/11

TO CN102
sheet 11/11

TO CN200
OF LVA10219-4
sheet 5/11

TO CN240
OF LVA10219-5
sheet 5/11

TO CN807
OF LVA10223
sheet 6/11

FROM CN82
OF LVA10221-3

TO CN831
OF LVA10221-1
sheet 2/11

FROM CN410
OF LVA10218-1
sheet 10/11

TO CN931
OF LVA10221-2
sheet 2/11

*MARK	RX-8010	RX-9010
D905	J-C	B-E-EN
R930	USE	USE
R999	USE	USE
R934	USE	USE
R935	USE	USE
R936	USE	USE
CN102	USE	USE
R917	SHORT	SHORT

➔ TUNER Signal

▲ Parts are safety assurance parts.
When replacing those parts make
sure to use the specified one.

A B C 2-6 D E F G H

Video / S video signal input section

5

4

3

2

1

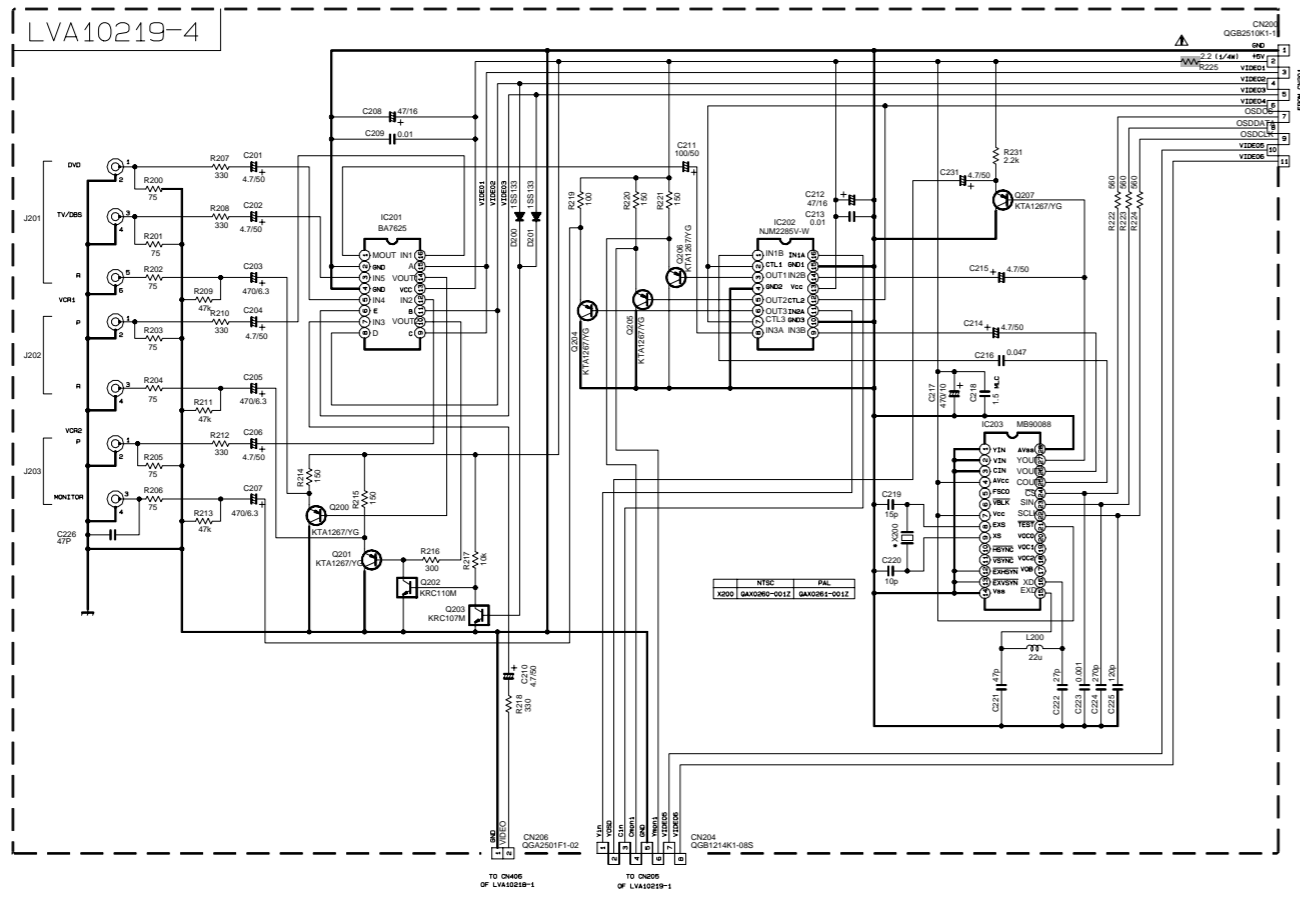

sheet 10/11 sheet 6/11

sheet 3/11

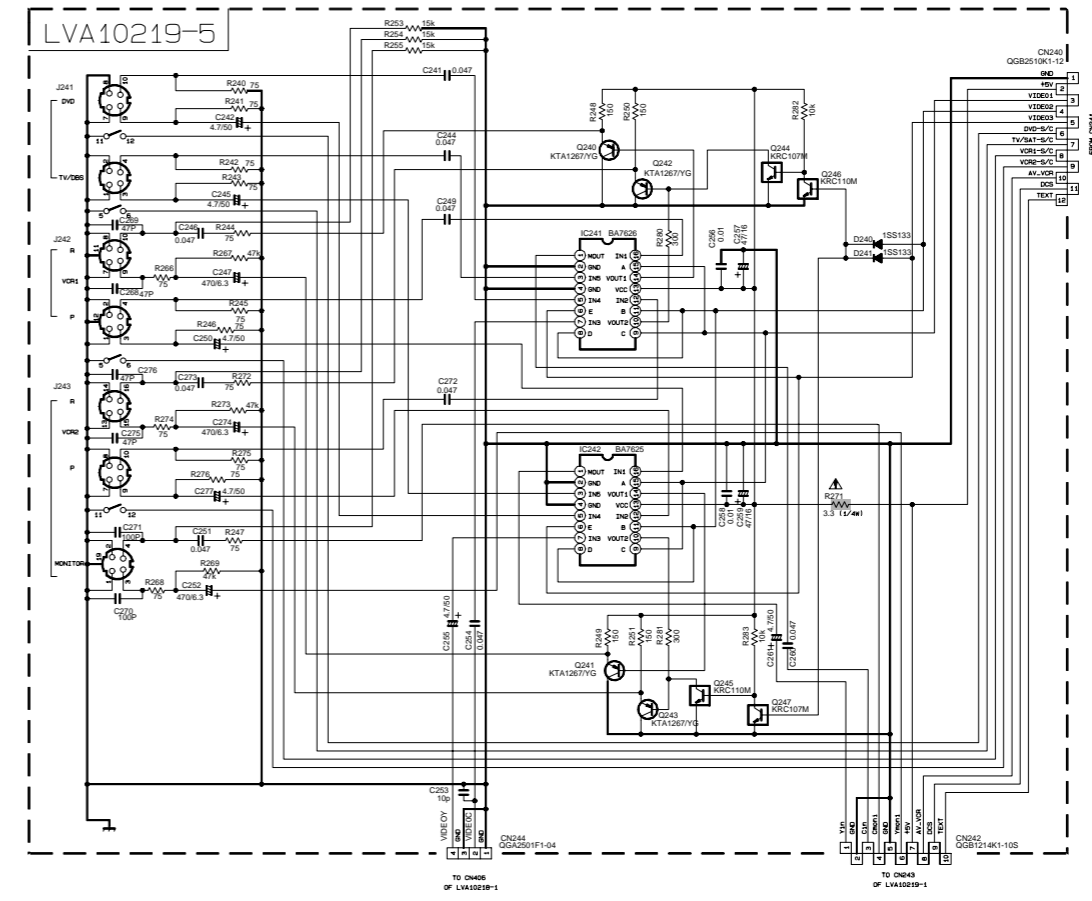

sheet 10/11 sheet 6/11

sheet 3/11

⚠ Parts are safety assurance parts. When replacing those parts make sure to use the specified one.

DVD section

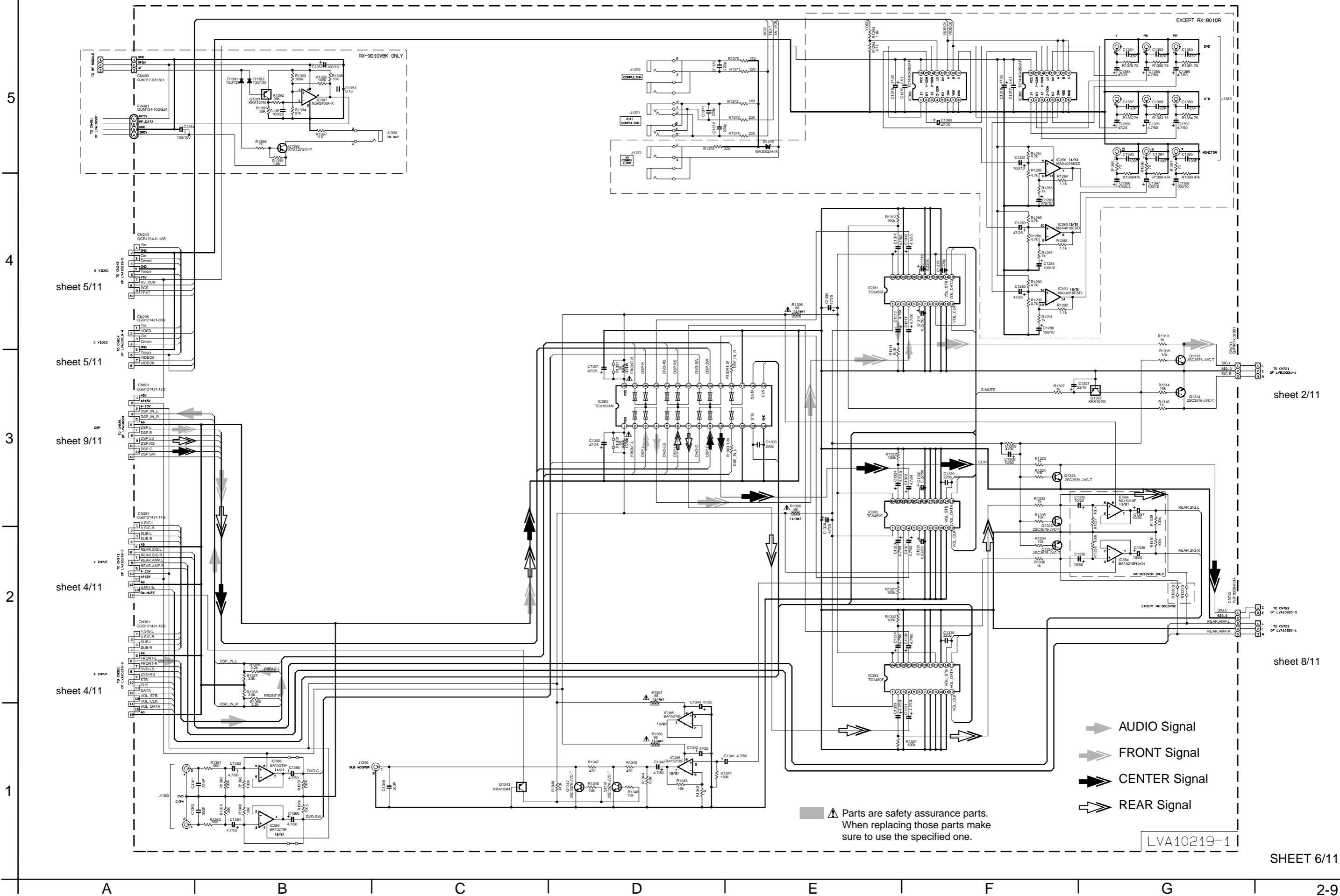

- ➔ AUDIO Signal
- ➔ FRONT Signal
- ➔ CENTER Signal
- ➔ REAR Signal

⚠ Parts are safety assurance parts.
When replacing those parts make
sure to use the specified one.

LVA10219-1

Audio amplifier section (1/2)

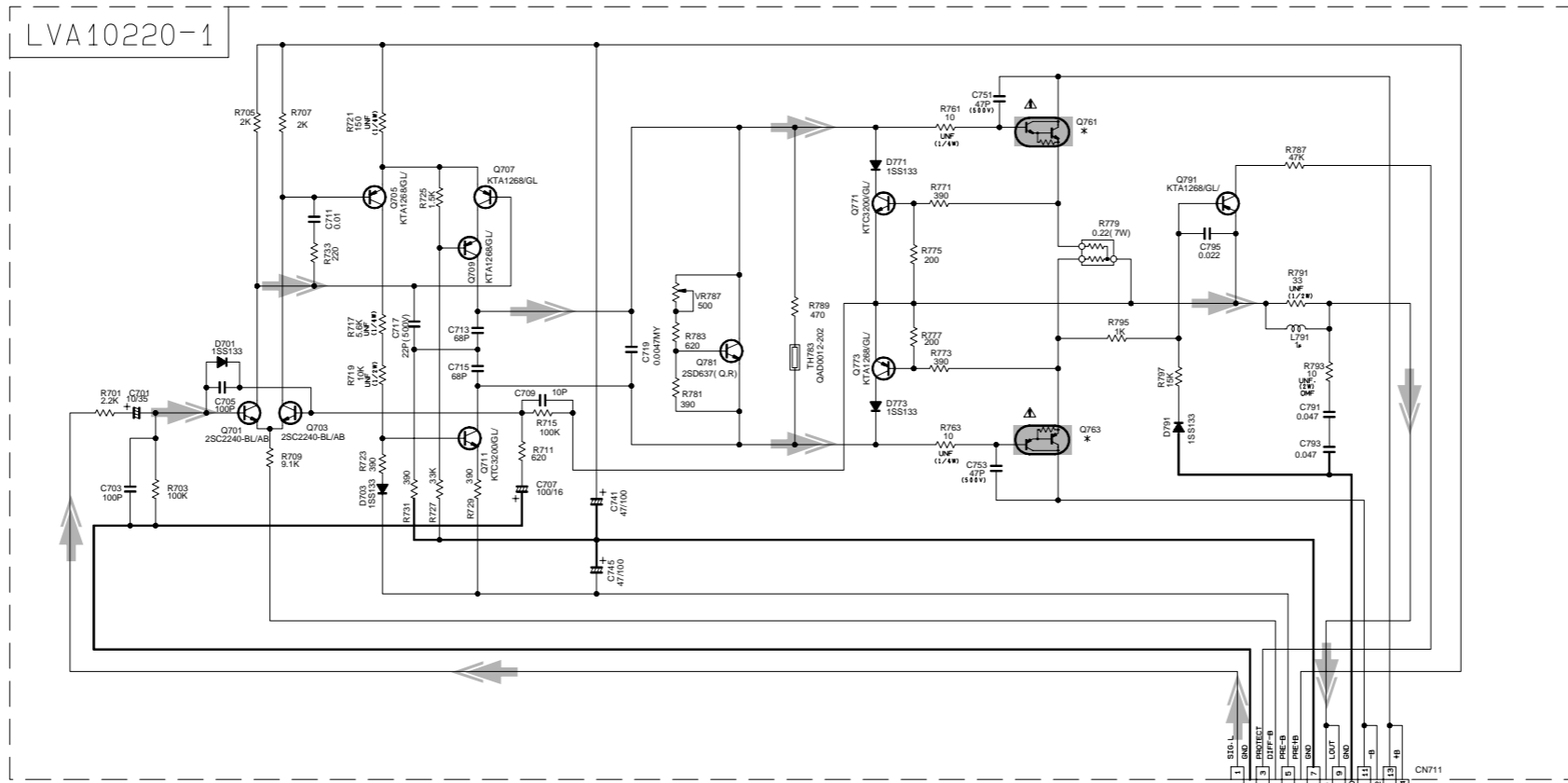

FROM CN701 OF LVA10221-1

sheet 2/11

*MARK	RX-8010		RX-9010
	B. E. EN. US. UN. UM	↓C	
Q761, Q762	2SD2390/OPY/-F6	2SD2560/OPY/-F6	2SD2560/OPY/-F6
Q763, Q764	2SB1560/OPY/-F6	2SB1647/OPY/-F6	2SB1647/OPY/-F6

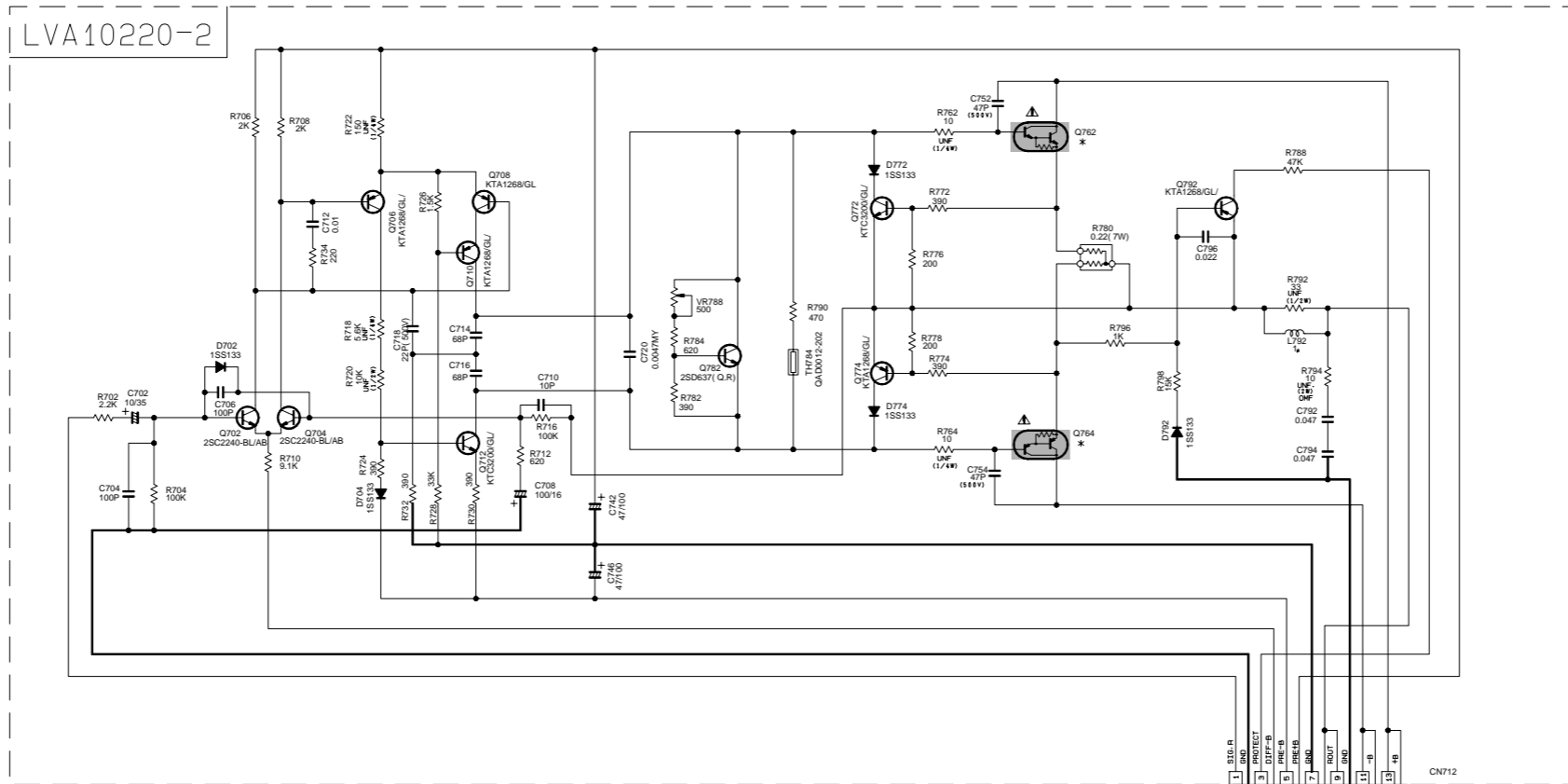

FROM CN702 OF LVA10221-1

sheet 2/11

➔ FRONT Signal

⚠ Parts are safety assurance parts. When replacing those parts make sure to use the specified one.

■ Audio amplifier section (2/2)

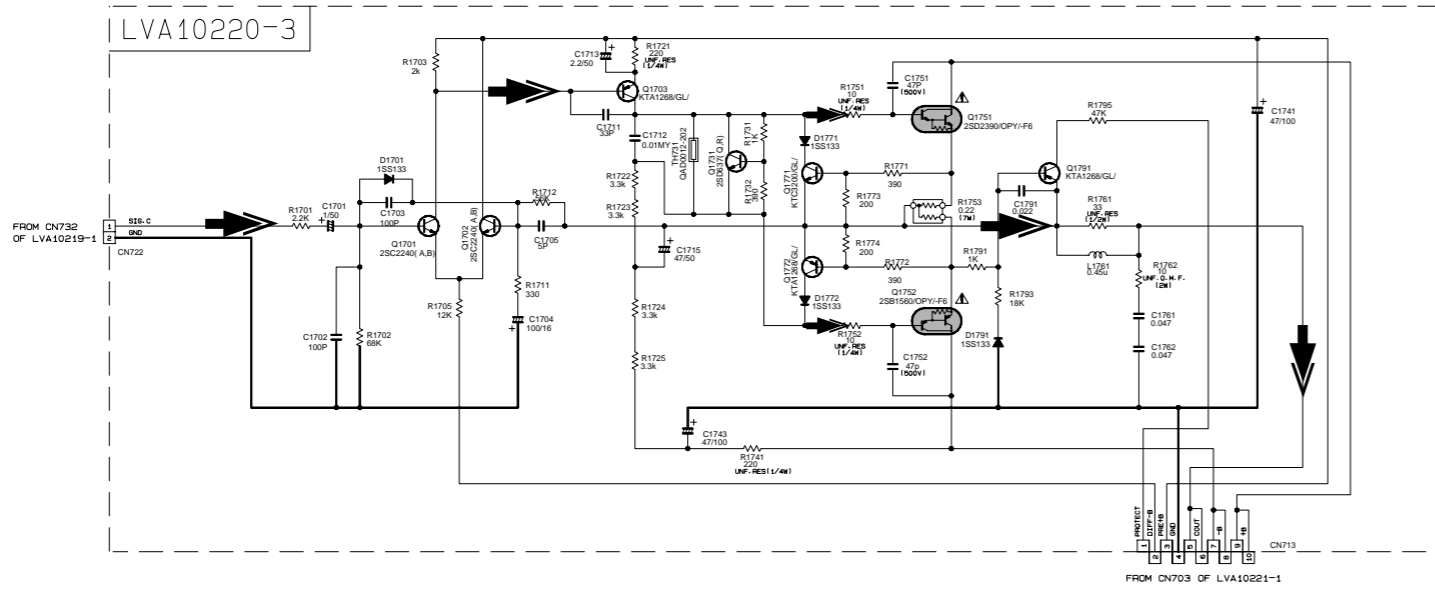

sheet 2/11

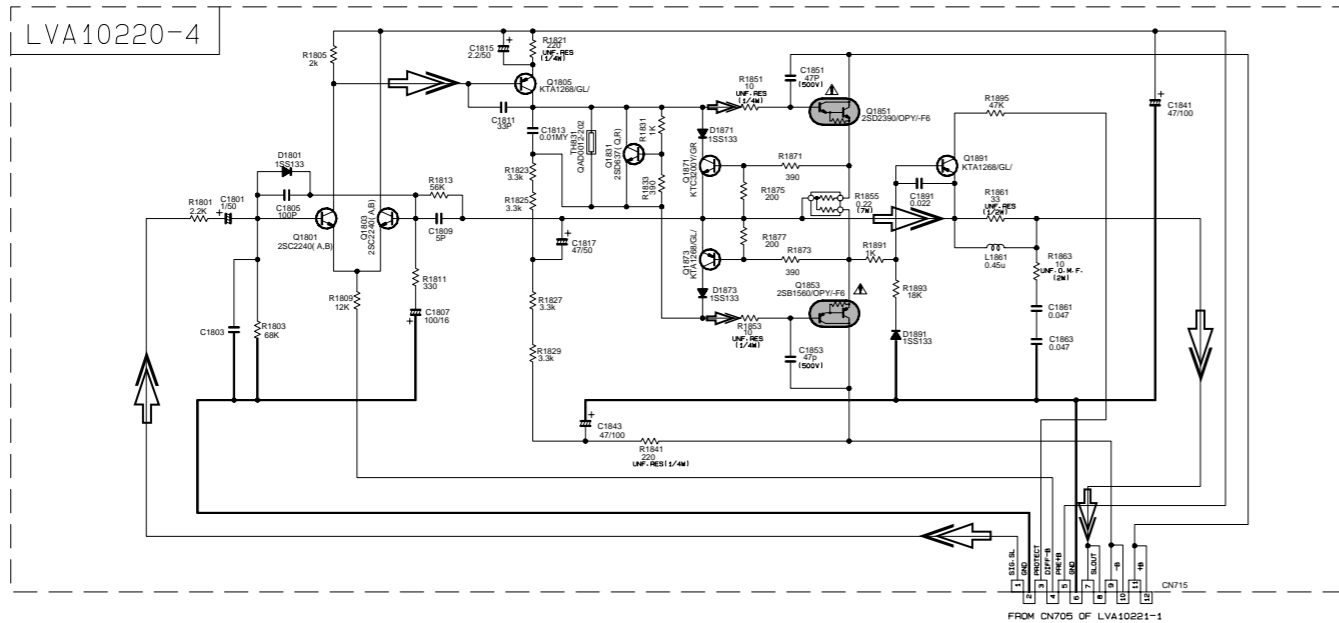

sheet 2/11

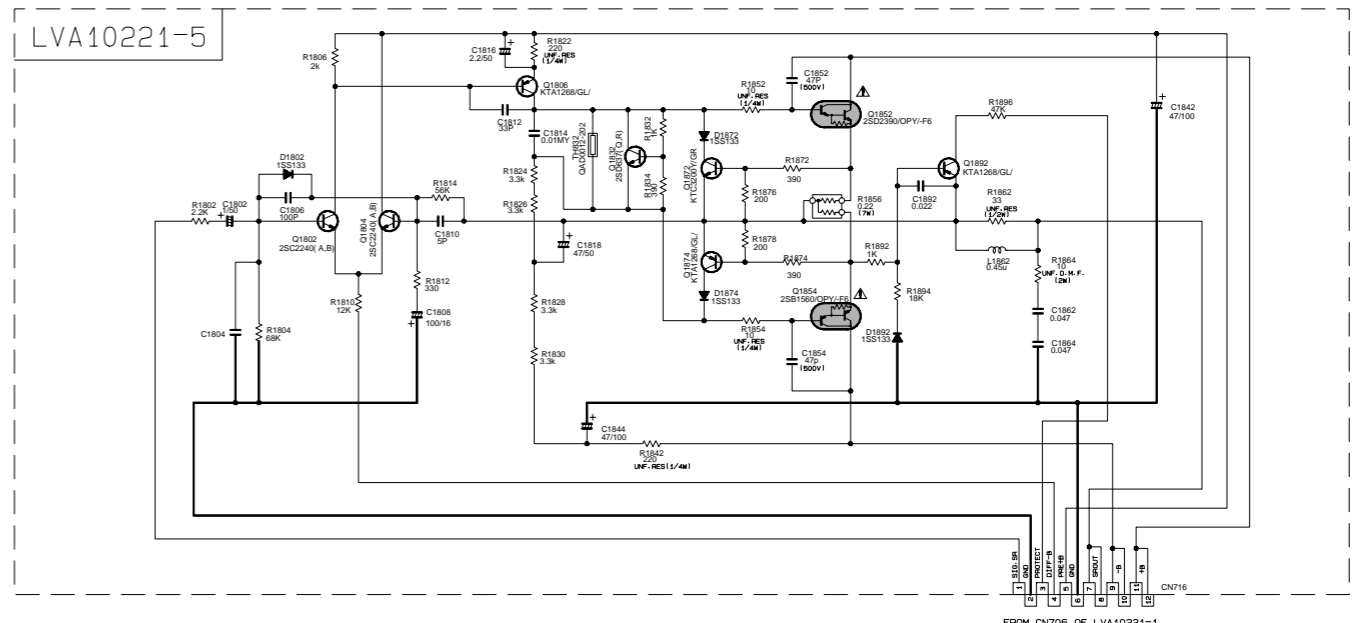

sheet 2/11

DSP section

5

4

3

2

1

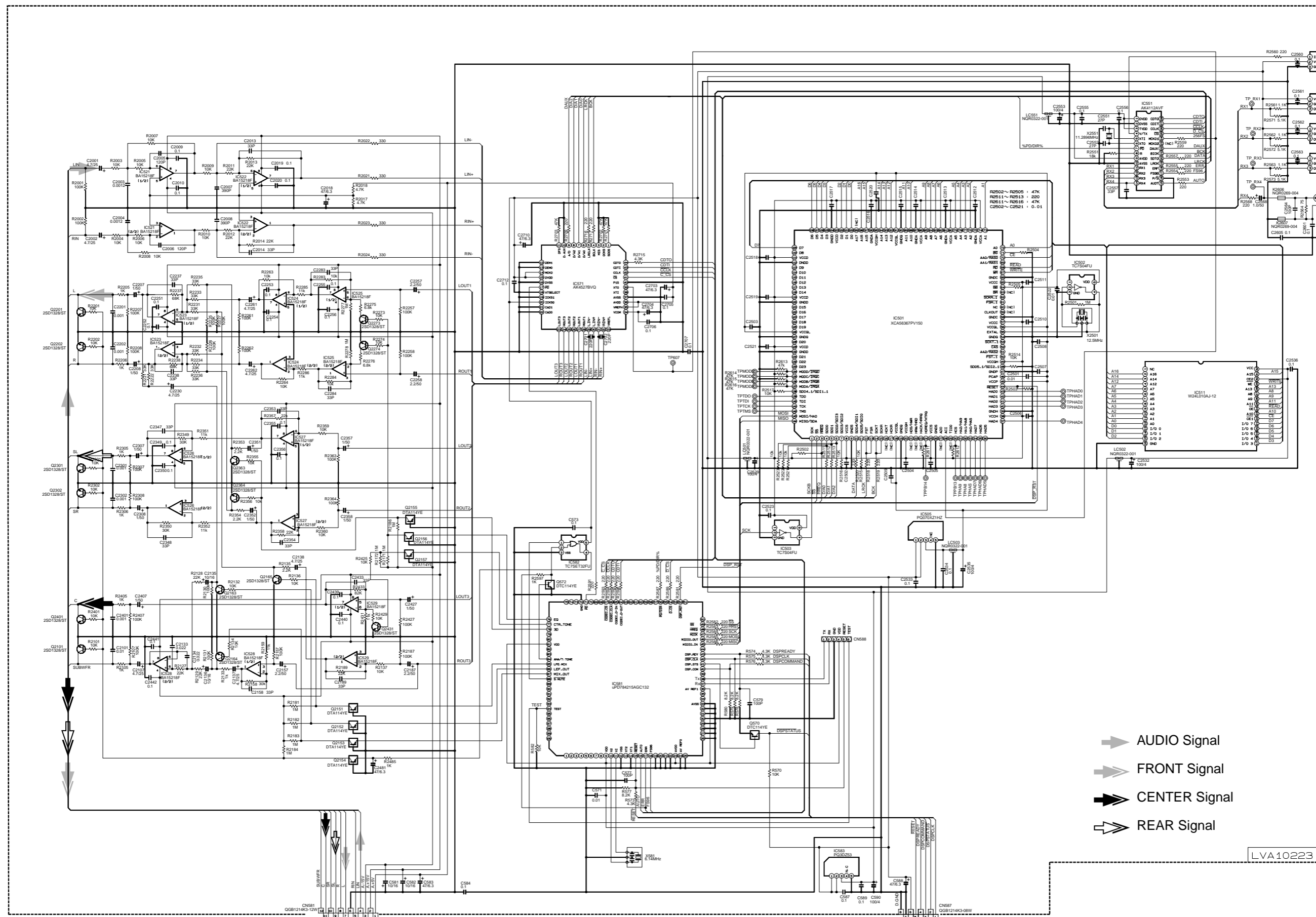

System control & FL display section

LVA10218-1

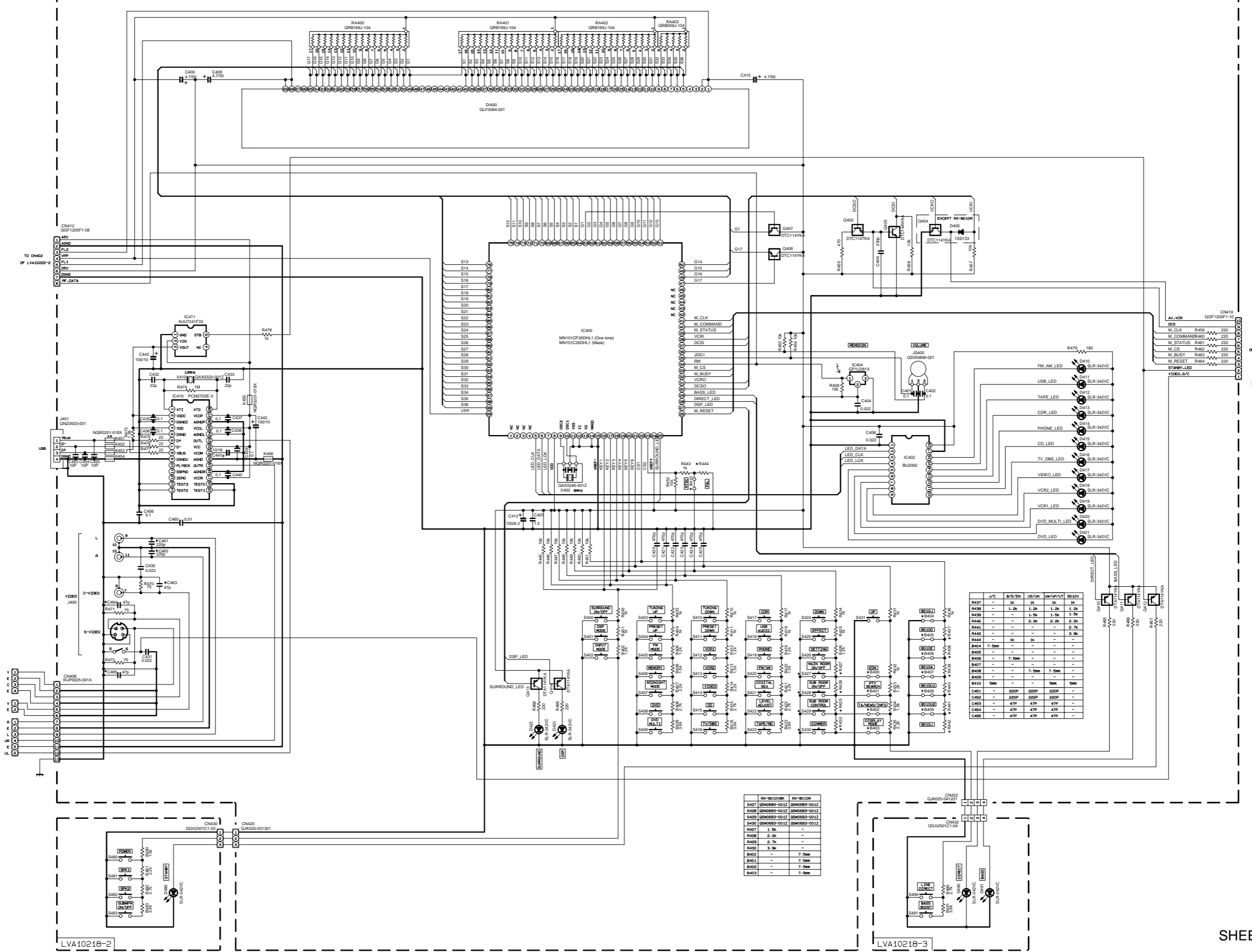

5

4

3

2

1

sheet 5/11 TO CN44 OF LVA10219-5

sheet 5/11 TO CN06 OF LVA10219-4

sheet 4/11 TO CN49 OF LVA10219-3

LVA10218-2

LVA10218-3

Part No.	Value	Part No.	Value
R427	1.5k	R430	3.3k
R428	3.3k	R431	7.5m
R429	2.7k	R432	7.5m
R430	3.3k	R433	7.5m
R431	7.5m		
R432	7.5m		
R433	7.5m		

J/C	B/E/EN	US/LN	UN/AP/AT	50/10V
R437	-	1k	1k	1k
R438	-	1.2k	1.2k	1.2k
R439	-	1.5k	1.5k	1.5k
R440	-	2.2k	2.2k	2.2k
R441	-	2.2k	2.2k	2.2k
R442	-	3.3k	3.3k	3.3k
R443	7.5m	-	-	-
R444	7.5m	-	-	-
R445	7.5m	-	-	-
R446	7.5m	-	-	-
R447	-	7.5m	7.5m	-
R448	-	-	-	-
R449	-	-	-	-
R450	5m	-	5m	5m
R451	-	200p	200p	200p
R452	-	200p	200p	200p
R453	-	47p	47p	47p
R454	-	47p	47p	47p
R455	-	47p	47p	47p

sheet 2/11

■ Tuner section

FOR J, C, U, A
LVA10009

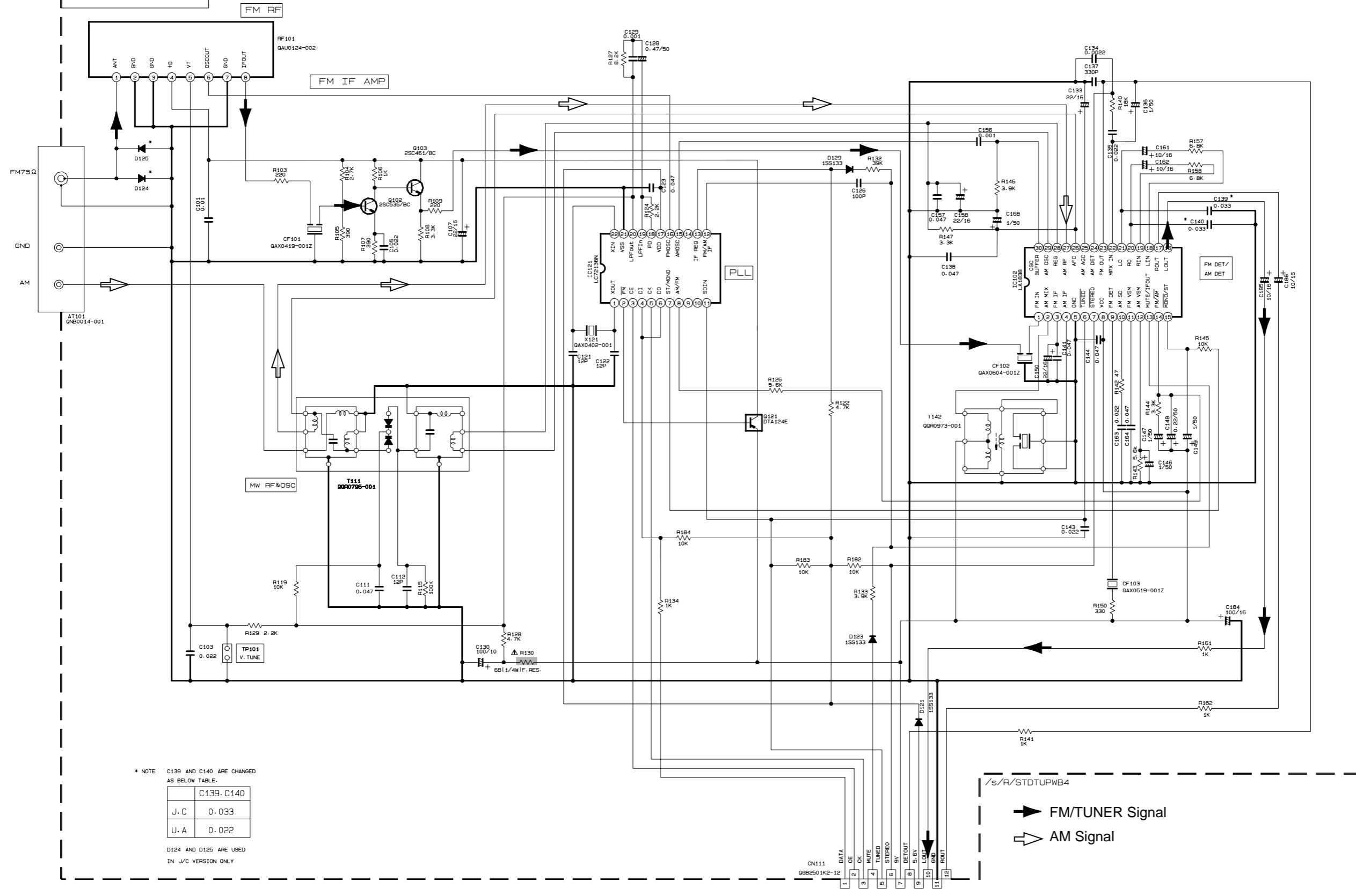

* NOTE C139 AND C140 ARE CHANGED AS BELOW TABLE.

	C139: C140
J. C	0.033
U. A	0.022

D124 AND D125 ARE USED IN J/C VERSION ONLY

/s/R/STDUPWB4

➔ FM/TUNER Signal
➤ AM Signal

TO CN101
CN111 06B2501K2-12

■ Micon board

5

4

3

2

1

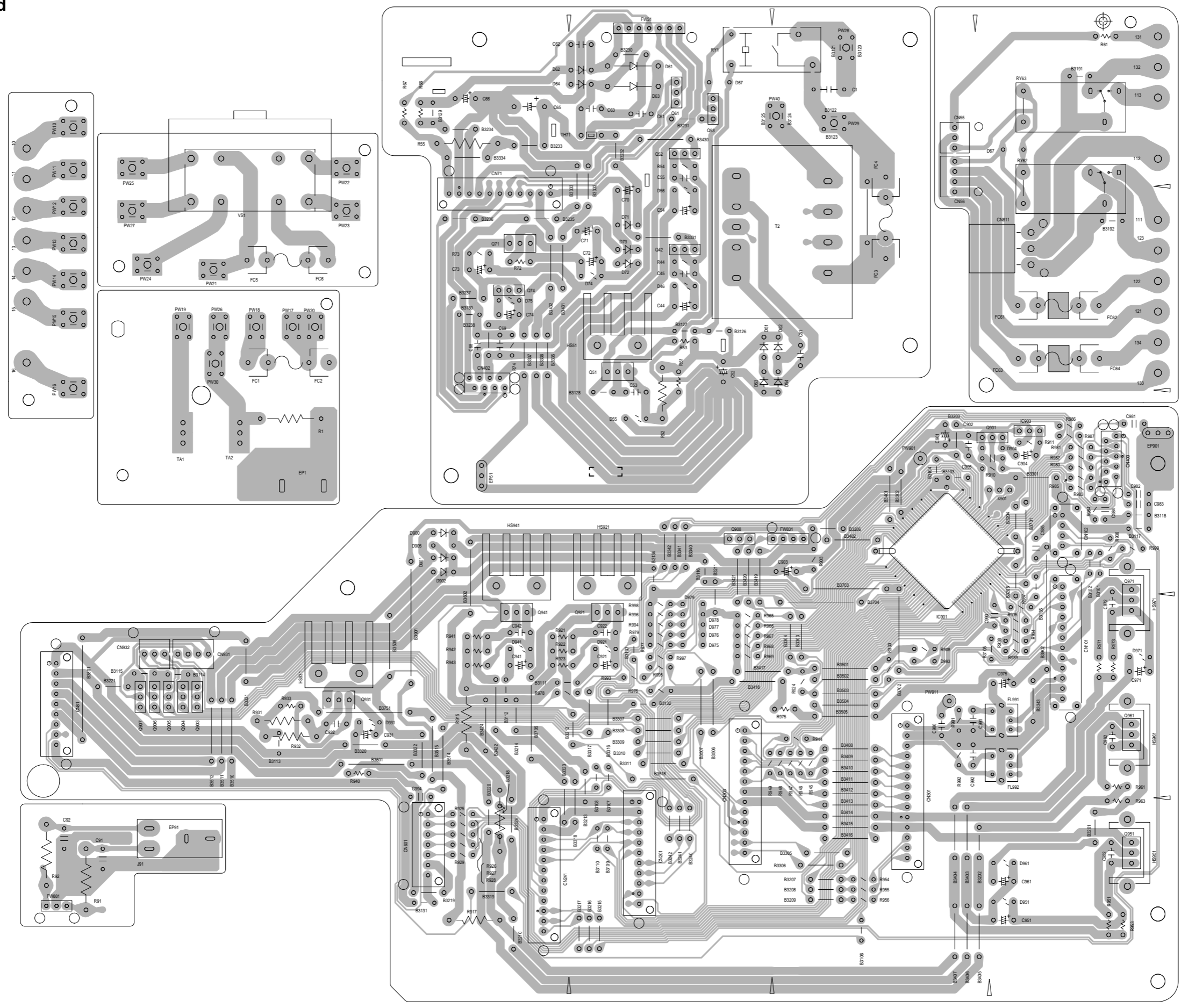

A

B

C

2-16

D

E

F

G

H

■ Front board

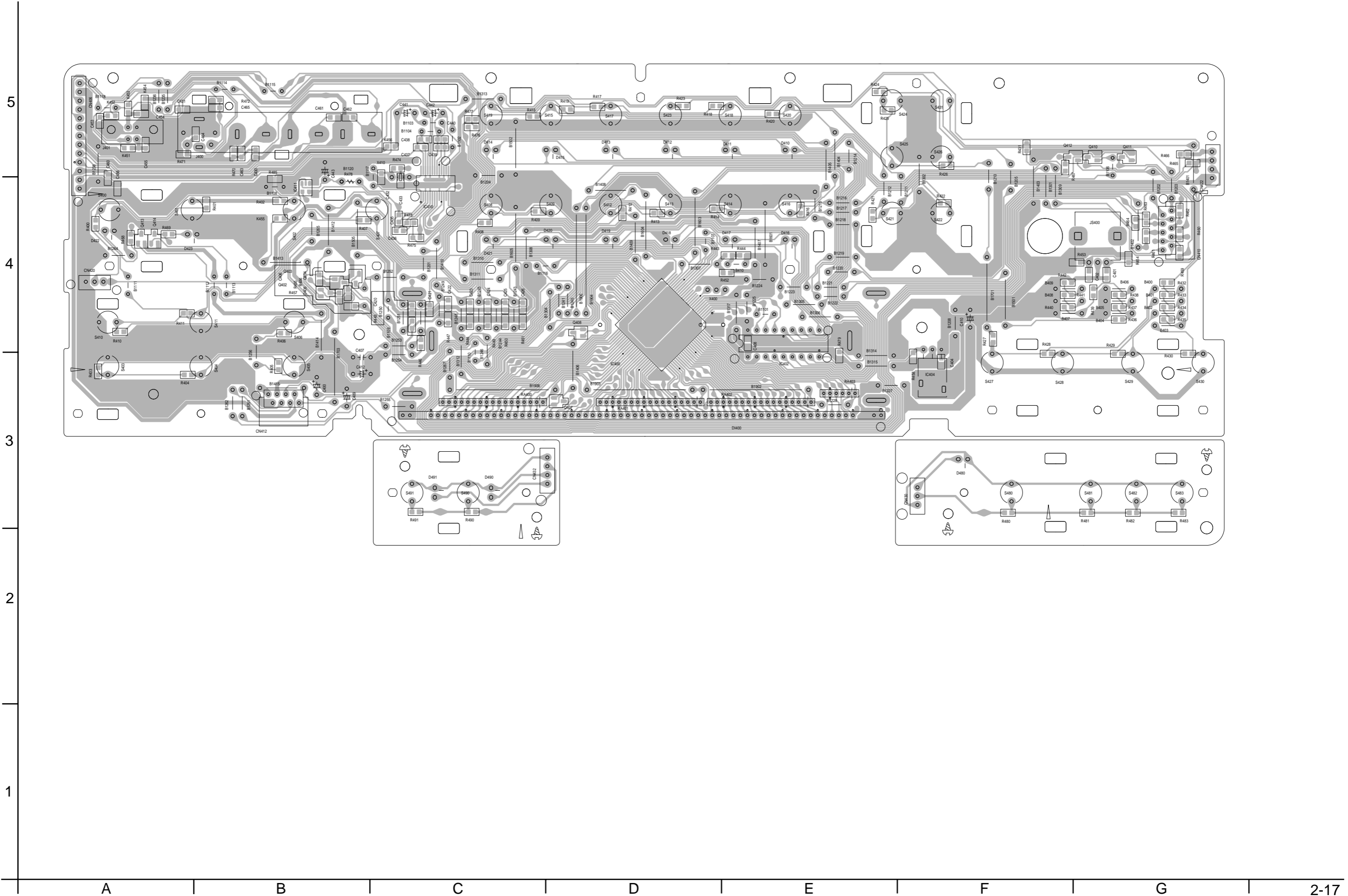

■ Input board (Reverse side)

5

4

3

2

1

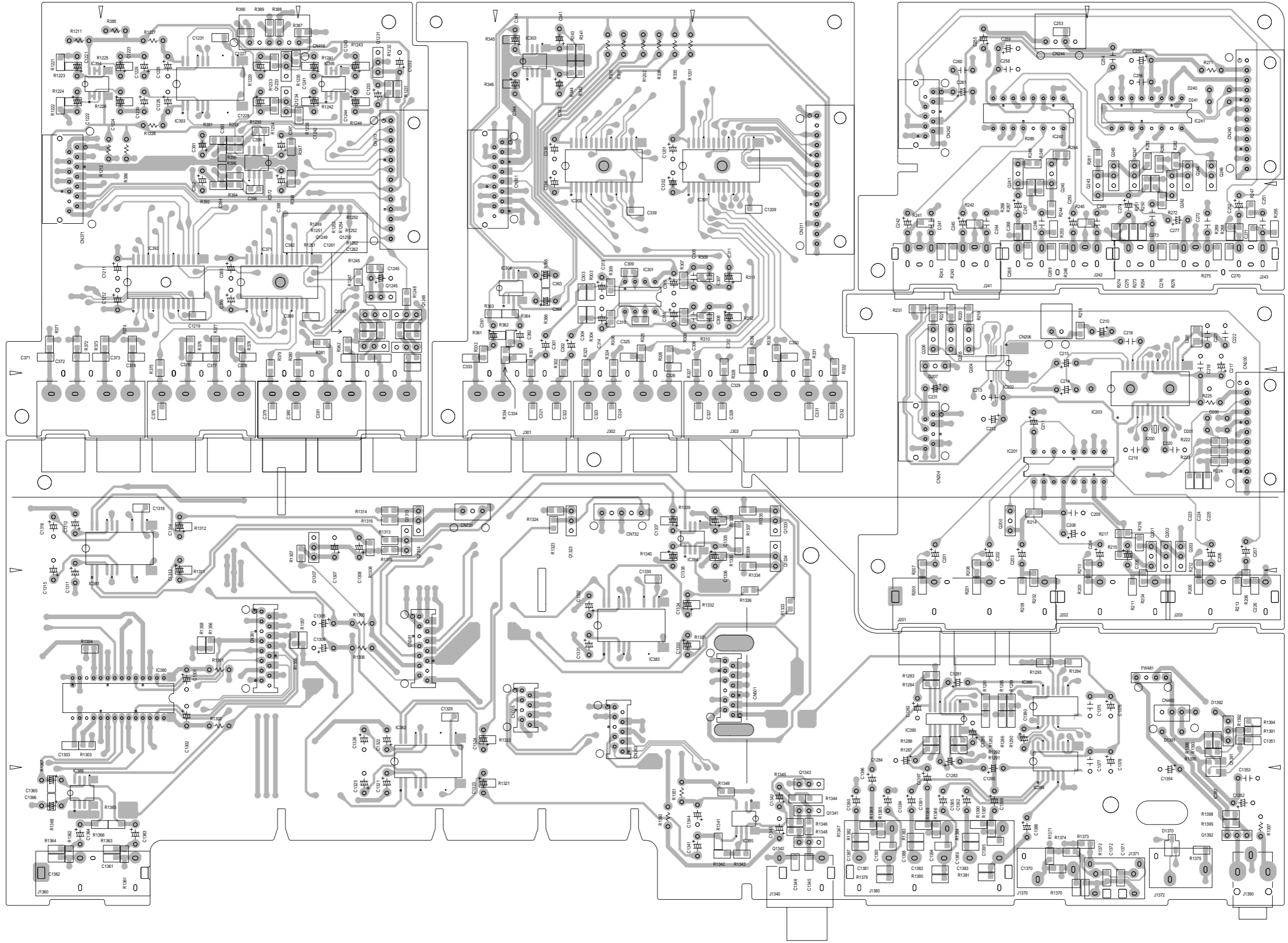

A

B

C

2-18

D

E

F

G

H

■ Input board (Forward side)

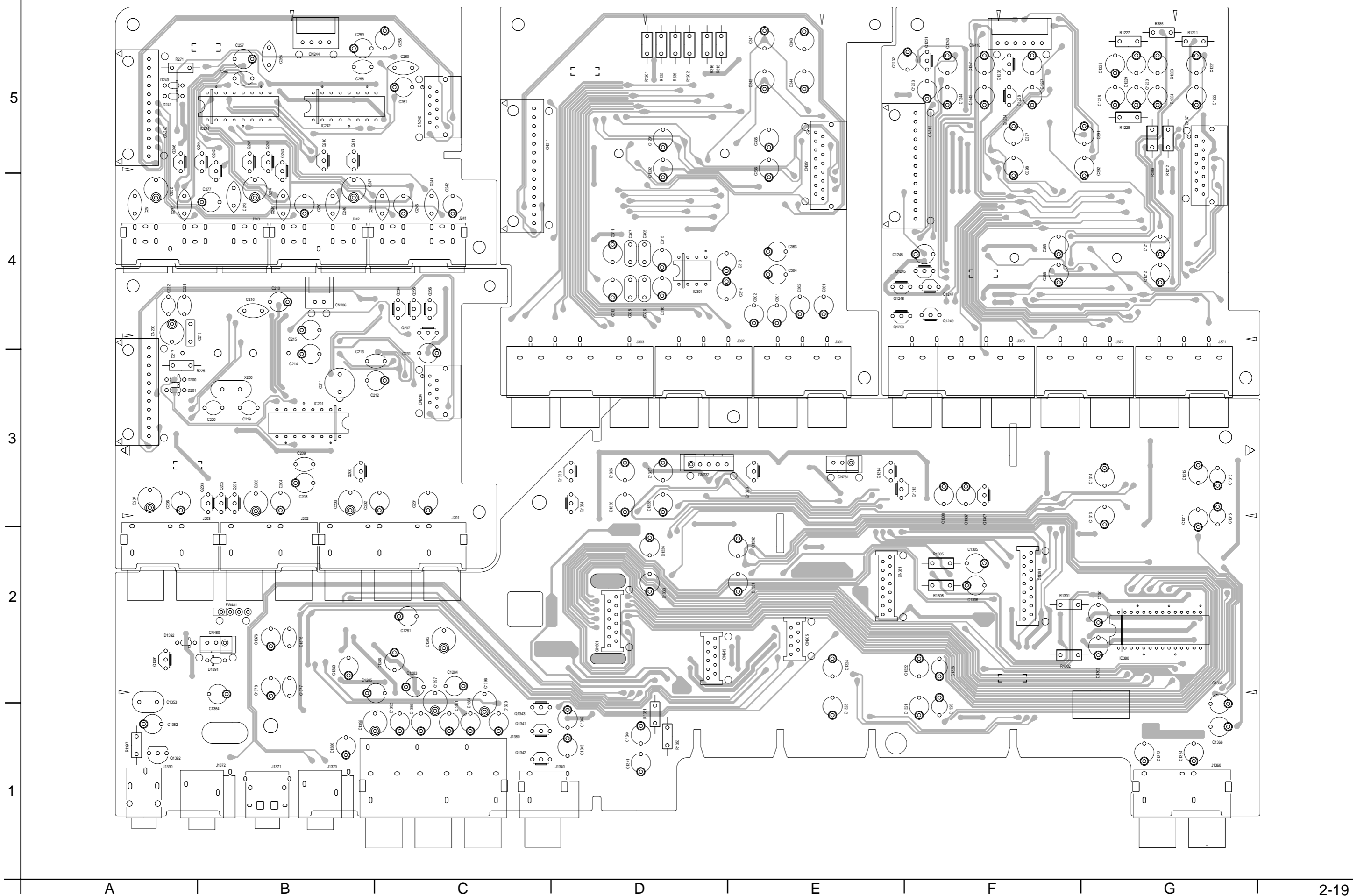

■ Tuner board

5
4
3
2
1

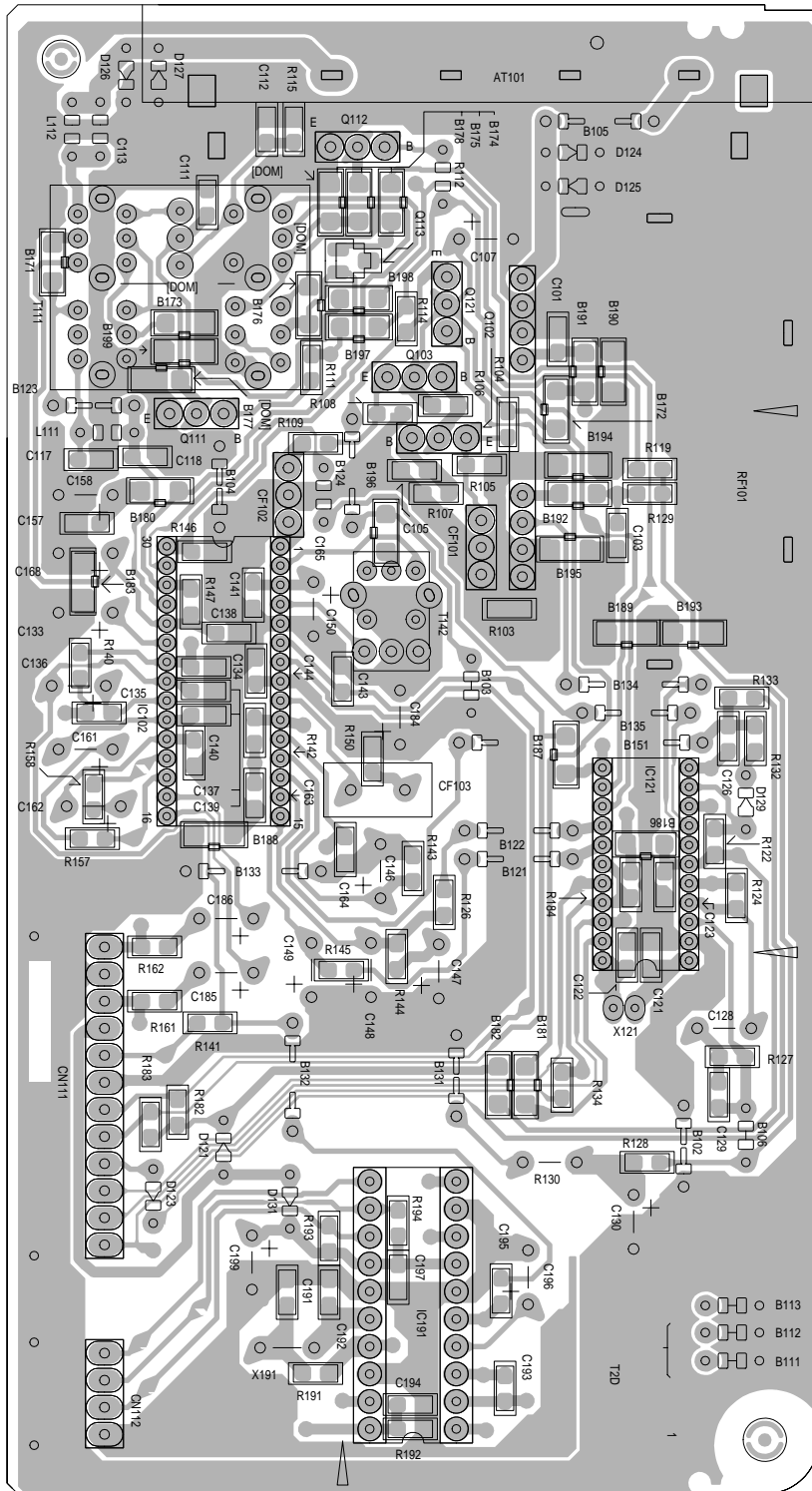

PARTS LIST

[RX-8010VBK]

* All printed circuit boards and its assemblies are not available as service parts.

Area suffix

J ----- U.S.A.

- Contents -

Exploded view of general assembly and parts list	3- 3
Electrical parts list	3- 5
Packing materials and accessories parts list	3-21

< M E M O >

Exploded view of general assembly and parts list

Block No. **M 1 M M**

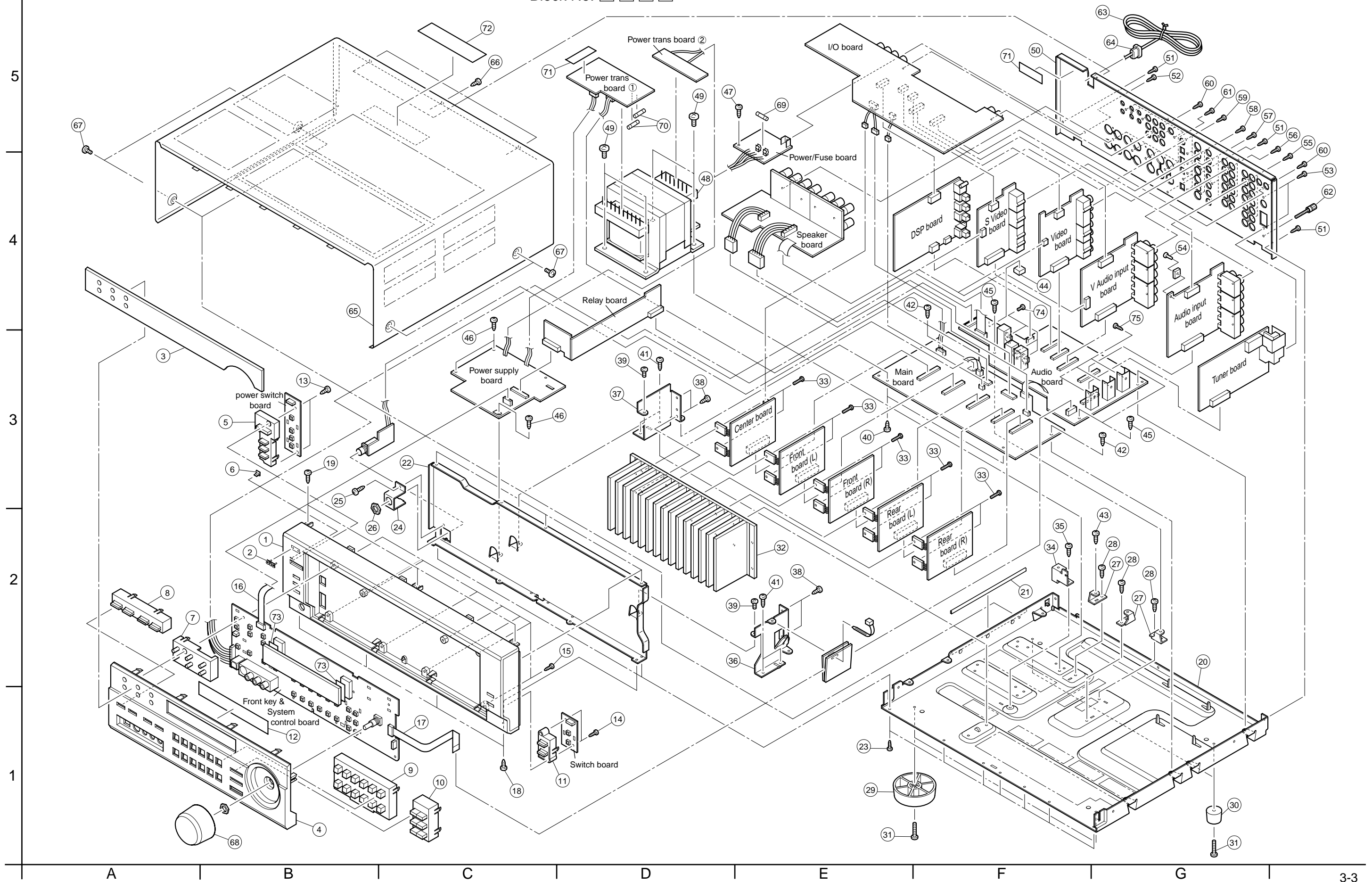

■ Parts list (General assembly)

Block No. M1MM

△	Item	Parts number	Parts name	Q'ty	Description	Area
△	1	LV10469-001A	FRONT PANEL	1		
	2	VJD5429-001SS	JVC MARK	1		
	3	LV20949-004A	LENS	1		
	4	LV10470-001A	SUB PANEL	1		
	5	LV20939-001A	PUSH BUTTON	1	POWER BK	
	6	LV42096-001A	INDICATOR	1	POWER	
	7	LV20951-001A	PUSH BUTTON	1	TUNER	
	8	LV20940-001A	P.BUTTON ASSY	1	DOLBY	
	9	LV20944-001A	P.BUTTON ASSY	1	SOURCE	
	10	LV20942-001A	PUSH BUTTON	1	SEA	
	11	LV32486-001A	P.BUTTON ASSY	1	LINE STRAIGHT	
	12	LV42095-002A	FL SCREEN	1	FL	
	13	QYSDSF2608Z	SCREW	2	FRONT C.B	
	14	QYSDSF2608Z	SCREW	2		
	15	QYSDSF2608Z	SCREW	8	FRONT C.B FL	
	16	QUQ412-0815CJ	FFC WIRE	1		
	17	QUQ412-1030CJ	FFC WIRE	1		
	18	QYSDSG3006Z	SCREW	4	FRONT D	
	19	QYSBSG3006Z	T.SCREW	3	FRONT U	
	20	LV10019-003A	CHASSIS BASE	1		
	21	EXO150010H09S11	FELT SPACER	1	FOR C.BASE	
	22	LV10471-001A	FRONT BRACKET	1		
	23	QYSDSG3006Z	SCREW	7	C.B-F.B	
	24	LV42094-002A	H.P. BKT	1		
	25	QYSBSG3006Z	T.SCREW	1	H.P BKT-F.B	
	26	VKZ4150-001	SPECIAL NUT	1		
	27	E68587-223SM	CB BKT	3		
	28	QYSBST3006Z	T.SCREW	3	C.B-BKT	
	29	QZF6018-001	FOOT	2		
	30	E47227-036	FOOT	2		
	31	QYSBST3010Z	T.SCREW	4	FOOT	
	32	LV20984-002A	HEAT SINK	1		
	33	E73525-003SS	SCREW	10	TR	
	34	LV42098-001A	C.B BKT	1	PRI/SEC C.B	
	35	QYSBST3006Z	T.SCREW	1	C.B BKT	
	36	LV32433-001A	H.S BRACKET(R)	1		
	37	LV32434-001A	H.S BRACKET(L)	1		
	38	QYSBSG3008Z	T.SCREW	4	H.S-BKT	
	39	QYSBSG3006Z	T.SCREW	2	H.S BKT-F.BKT	
	40	QYSBSG3006Z	T.SCREW	2	H.S BKT	
	41	QYSBST3006Z	T.SCREW	4	H.S BKT-CHASSIS	
	42	QYSBSG3006Z	T.SCREW	2	M.C.B	
	43	E65923-003	TAPPING SCREW	1	M.C.B	
	44	LV30225-0B2A	SPACER	1		
	45	QYSBSG3006Z	T.SCREW	3	H.S-C.B	
	46	QYSBSG3006Z	T.SCREW	3	P.C.B	
	47	QYSBSG3006Z	T.SCREW	1	C.B-CHASSIS	
△	48	QQT0325-001	POWER TRANS.	1		

■ Parts list (General assembly)

Block No. M1MM

△	Item	Parts number	Parts name	Q'ty	Description	Area
	49	QYSDSTL4008Z	SPECIAL SCREW	4	P.TRANS	
	50	LV10472-008A	REAR PANEL	1		
	51	QYSBSGY3008M	SPECIAL SCREW	3	R.P-C.BASE	
	52	QYSBSGY3008M	SPECIAL SCREW	1	R.P-ud---	
	53	QYSBSGY3008M	SPECIAL SCREW	2	TUNER	
	54	FMYH4004-001	PLASTIC RIVET	1		
	55	QYSBSGY3008M	SPECIAL SCREW	4	A.INPUT	
	56	QYSBSGY3008M	SPECIAL SCREW	3	V.INPUT	
	57	QYSBSGY3008M	SPECIAL SCREW	3	VIDEO	
	58	QYSBSGY3008M	SPECIAL SCREW	4	S VIDEO	
	59	QYSBSGY3008M	SPECIAL SCREW	6	DIGITAL	
	60	QYSBSGY3008M	SPECIAL SCREW	7	COMPONENT	
	61	QYSBSGY3008M	SPECIAL SCREW	4	SPK C.B	
△	62	E409257-001	GND TERMINAL	1		
△	63	QMPD220-200-JD	POWER CORD	1		
△	64	QZW0033-001	STRAIN RELIEF	1		
	65	LV20038-009A/S/	TOP COVER	1		
	66	QYSBSGY3008M	SPECIAL SCREW	3		
	67	E406308-003	SPECIAL SCREW	4		
△	68	LV32435-003A	VOL KNOB	1	BK	
△	69	QMF51U1-6R3-J8	FUSE	1	F1	
△	70	QMF51U1-2R0-J8	FUSE	2	F61 F62	
	71	LV42388-001A	FUSE CAUTION	2		
	72	E409394-001	CAUTION LABEL	1		
	73	E3400-444	FELT SPACER	2	FS400 FS401	
	74	QYSBSG3008E	T.SCREW	3		
	75	QYSBSG3008E	T.SCREW	3		

■ Electrical parts list (Main board)

Block No. 01

△	Item	Parts number	Parts name	Remarks	Area
	C 801	QCE22HP-103	C CAPACITOR	.010MF +100:-0%	
	C 802	QCE22HP-103	C CAPACITOR	.010MF +100:-0%	
	C 805	QCE22HP-103	C CAPACITOR	.010MF +100:-0%	
	C 807	QEZ0462-688	E CAPACITOR	6800MF	
	C 808	QEZ0462-688	E CAPACITOR	6800MF	
	C 811	QCF31HZ-472Z	C CAPACITOR	4700PF +80:-20%	
	C 816	QETN1EM-476Z	E CAPACITOR	47MF 20% 25V	
	C 823	QETN1CM-476Z	E CAPACITOR	47MF 20% 16V	
	C 824	QETN1EM-106Z	E CAPACITOR	10MF 20% 25V	
	CN 72	QGB2510K1-11	CONNECTOR		
	CN 82	QGB2510K1-09	CONNECTOR		
	CN701	QGB2510J1-14	CONNECTOR		
	CN702	QGB2510J1-14	CONNECTOR		
	CN703	QGB2510J1-10	CONNECTOR		
	CN705	QGB2510J1-12	CONNECTOR		
	CN706	QGB2510J1-12	CONNECTOR		
	CN721	QGA2501C1-03	3P CONNECTOR		
	CN723	QGA2501C1-04	4P CONNECTOR		
	CN801	QJK012-032403	SKT WIRE ASSY		
	CN813	QGA3901C1-04	4P CONNECTOR		
	CN814	QGA3901C1-06	6P PLUG ASSY		
△	CN823	QJK015-043004	SKT WIRE ASSY		
△	CN824	QJK015-063504	SKT WIRE ASSY		
	CN831	QGD2501C1-04Z	SOCKET		
	CN881	QGD2501C1-03Z	SOCKET		
△	D 801	30DF2-FC	DIODE		
△	D 802	30DF2-FC	DIODE		
△	D 803	30DF2-FC	DIODE		
△	D 804	30DF2-FC	DIODE		
	D 811	MTZJ24C-T2	Z DIODE		
	D 816	MTZJ18C-T2	Z DIODE		
	D 825	1SS133-T2	SI DIODE		
	D 831	1SS133-T2	SI DIODE		
	D 832	1SS133-T2	SI DIODE		
	D 851	1SS133-T2	SI DIODE		
	D 852	1SS133-T2	SI DIODE		
	D 871	1SS133-T2	SI DIODE		
	EP801	QNZ0136-001Z	EARTH PLATE		
	FW931	QUM137-08DGZ4	PARA RIBON WIRE		
	Q 811	2SD2395/EF/	TRANSISTOR		
	Q 812	KTC3200/GL/-T	TRANSISTOR		
	Q 823	KTC3199/GL/-T	TRANSISTOR		
	Q 824	KTC3200/GL/-T	TRANSISTOR		
	Q 825	KTA1268/GL/-T	TRANSISTOR		
	R 801	QRE141J-104Y	C RESISTOR	100K 5% 1/4W	
	R 802	QRE141J-104Y	C RESISTOR	100K 5% 1/4W	
	R 811	QRJ146J-150X	UNF C RESISTOR	15 5% 1/4W	
	R 812	QRK126J-332X	UNF C RESISTOR	3.3K 5% 1/2W	
	R 813	QRE141J-473Y	C RESISTOR	47K 5% 1/4W	
	R 814	QRE141J-103Y	C RESISTOR	10K 5% 1/4W	
	R 815	QRJ146J-120X	UNF C RESISTOR	12 5% 1/4W	
	R 816	QRL022J-332	UNF OMF RESISTOR	3.3K 5% 1/2W	
	R 823	QRE141J-103Y	C RESISTOR	10K 5% 1/4W	
	R 824	QRE141J-134Y	C RESISTOR	130K 5% 1/4W	
	R 825	QRE141J-103Y	C RESISTOR	10K 5% 1/4W	
	R 826	QRE141J-104Y	C RESISTOR	100K 5% 1/4W	
	R 831	QRJ146J-120X	UNF C RESISTOR	12 5% 1/4W	
	R 832	QRJ146J-120X	UNF C RESISTOR	12 5% 1/4W	
	R 841	QRE141J-104Y	C RESISTOR	100K 5% 1/4W	
	R 842	QRE141J-823Y	C RESISTOR	82K 5% 1/4W	
	R 843	QRE141J-104Y	C RESISTOR	100K 5% 1/4W	
	R 844	QRE141J-104Y	C RESISTOR	100K 5% 1/4W	
	R 845	QRE141J-823Y	C RESISTOR	82K 5% 1/4W	

△	Item	Parts number	Parts name	Remarks	Area
	R 851	QRJ146J-120X	UNF C RESISTOR	12 5% 1/4W	
	R 852	QRJ146J-120X	UNF C RESISTOR	12 5% 1/4W	
	R 871	QRJ146J-120X	UNF C RESISTOR	12 5% 1/4W	
	RY831	QSK0109-001	RELAY		
	RY832	QSK0109-001	RELAY		
	RY851	QSK0109-001	RELAY		
	RY852	QSK0109-001	RELAY		
	RY871	QSK0109-001	RELAY		
	S 831	QSW0509-001	SLIDE SWITCH		
	ST831	QNB0105-002	SPK TERMINAL		
	ST851	QNB0078-001	SPK TERMINAL		

■ Electrical parts list (Front board)

Block No. 02

△	Item	Parts number	Parts name	Remarks	Area	△	Item	Parts number	Parts name	Remarks	Area
	BK400	LV42092-001A	FL HOLDER(R)				IC410	PCM2702E-X	IC		
	BK401	LV42093-001A	FL HOLDER(L)				IC411	NJU7241F33-X	IC		
	C 400	QEK1HM-475Z	E CAPACITOR	4.7MF 20% 50V			J 400	QND0026-001	S JACK		
	C 401	NCB31CK-104X	C CAPACITOR				J 401	QNZ0503-001	USB JACK		
	C 402	NCB31CK-104X	C CAPACITOR				JS400	QSW0898-001	JOG VOLUME		
	C 404	NCB31EK-223X	C CAPACITOR				K 451	NQR0201-018X	INDUCTOR		
	C 406	NCB31HK-331X	C CAPACITOR				K 452	NQR0201-018X	INDUCTOR		
	C 407	QCZ0205-155Z	ML C CAPACITOR	1.5MF			K 453	NQR0201-018X	INDUCTOR		
	C 408	NCB31EK-223X	C CAPACITOR				K 454	NQR0201-018X	INDUCTOR		
	C 409	QEK1HM-475Z	E CAPACITOR	4.7MF 20% 50V			K 455	NQR0201-018X	INDUCTOR		
	C 410	QEK1HM-475Z	E CAPACITOR	4.7MF 20% 50V			K 456	NQR0201-018X	INDUCTOR		
	C 411	QCZ0205-155Z	ML C CAPACITOR	1.5MF			Q 402	DTC114TKA-X	TRANSISTOR		
	C 412	QEK0JM-107Z	E CAPACITOR	100MF 20% 6.3V			Q 403	DTC144WKA-X	TRANSISTOR		
	C 420	NCB31HK-471X	C CAPACITOR				Q 404	DTC114YKA-X	CHIP D TRANSIST		
	C 421	NCB31HK-471X	C CAPACITOR				Q 407	DTC114YKA-X	CHIP D TRANSIST		
	C 422	NCB31HK-471X	C CAPACITOR				Q 408	DTC114YKA-X	CHIP D TRANSIST		
	C 423	NCB31HK-471X	C CAPACITOR				Q 410	DTA114YKA-X	TRANSISTOR	(DIRECT)	
	C 424	NCB31HK-471X	C CAPACITOR				Q 411	DTA114YKA-X	TRANSISTOR	(BASS)	
	C 425	NCB31HK-471X	C CAPACITOR				Q 412	DTA114YKA-X	TRANSISTOR	(STANBY)	
	C 430	NCB31EK-223X	C CAPACITOR				Q 413	DTA114YKA-X	TRANSISTOR	(SURROUND)	
	C 431	NCB31EK-223X	C CAPACITOR				Q 414	DTA114YKA-X	TRANSISTOR	(DSP)	
	C 432	NCS31HJ-220X	C CAPACITOR				R 400	NRSA63J-102X	MG RESISTOR		
	C 433	NCS31HJ-220X	C CAPACITOR				R 401	NRSA63J-102X	MG RESISTOR		
	C 435	NCB31EK-104X	C CAPACITOR				R 402	NRSA63J-122X	MG RESISTOR		
	C 436	NCB31EK-104X	C CAPACITOR				R 403	NRSA63J-102X	MG RESISTOR		
	C 437	NCB31EK-104X	C CAPACITOR				R 404	NRSA63J-102X	MG RESISTOR		
	C 438	NCB31EK-104X	C CAPACITOR				R 405	NRSA63J-122X	MG RESISTOR		
	C 439	NCB31EK-104X	C CAPACITOR				R 406	NRSA63J-152X	MG RESISTOR		
	C 440	NCB31EK-104X	C CAPACITOR				R 407	NRSA63J-222X	MG RESISTOR		
	C 441	QEK41CM-106	E CAPACITOR	10MF 20% 16V			R 408	NRSA63J-272X	MG RESISTOR		
	C 442	QETN1AM-107Z	E CAPACITOR	100MF 20% 10V			R 409	NRSA63J-392X	MG RESISTOR		
	C 443	QETN1AM-107Z	E CAPACITOR	100MF 20% 10V			R 410	NRSA63J-102X	MG RESISTOR		
	C 456	NCB31EK-104X	C CAPACITOR				R 411	NRSA63J-102X	MG RESISTOR		
	CN406	WJP0031-001A	C-B WIRE ASSY				R 412	NRSA63J-122X	MG RESISTOR		
	CN410	QGF1205F1-10	CONNECTOR				R 413	NRSA63J-152X	MG RESISTOR		
	CN412	QGF1205F1-08	CONNECTOR				R 414	NRSA63J-222X	MG RESISTOR		
	CN420	QJK025-031301	C-B WIRE ASSY	(LEFT)			R 415	NRSA63J-272X	MG RESISTOR		
	CN422	QJK025-041201	SIN ID C-B WIRE	(RIGHT)			R 416	NRSA63J-392X	MG RESISTOR		
	CN430	QGA2501C1-03	3P CONNECTOR				R 417	NRSA63J-102X	MG RESISTOR		
	CN432	QGA2501C1-04	4P CONNECTOR				R 418	NRSA63J-102X	MG RESISTOR		
	D 405	1SS133-T2	SI DIODE				R 419	NRSA63J-122X	MG RESISTOR		
	D 410	SLR-342VC-T	LED	(FM/AM)			R 420	NRSA63J-152X	MG RESISTOR		
	D 411	SLR-342VC-T	LED	(USB)			R 421	NRSA63J-222X	MG RESISTOR		
	D 412	SLR-342VC-T	LED	(TAPE)			R 422	NRSA63J-272X	MG RESISTOR		
	D 413	SLR-342VC-T	LED	(CDR)			R 423	NRSA63J-392X	MG RESISTOR		
	D 414	SLR-342VC-T	LED	(PHONE)			R 424	NRSA63J-102X	MG RESISTOR		
	D 415	SLR-342VC-T	LED	(CD)			R 425	NRSA63J-102X	MG RESISTOR		
	D 416	SLR-342VC-T	LED	(TV/DBS)			R 426	NRSA63J-122X	MG RESISTOR		
	D 417	SLR-342VC-T	LED	(VIDEO)			R 431	NRSA63J-102X	MG RESISTOR		
	D 418	SLR-342VC-T	LED	(VCR2)			R 432	NRSA63J-102X	MG RESISTOR		
	D 419	SLR-342VC-T	LED	(VCR1)			R 433	NRSA63J-122X	MG RESISTOR		
	D 420	SLR-342VC-T	LED	(DVD MULTI)			R 434	NRSA63J-152X	MG RESISTOR		
	D 421	SLR-342VC-T	LED	(DVD)			R 435	NRSA63J-222X	MG RESISTOR		
	D 422	SLR-342VC-T	LED	(SURROUND)			R 436	NRSA63J-102X	MG RESISTOR		
	D 423	SLR-342VC-T	LED	(DSP)			R 443	NRSA63J-102X	MG RESISTOR		
	D 480	SLR-342VC-T	LED	(STANDBY)			R 445	NRSA63J-103X	MG RESISTOR		
	D 490	SLR-342VC-T	LED	(DIRECT)			R 446	NRSA63J-103X	MG RESISTOR		
	D 491	SLR-342VC-T	LED	(BASS)			R 447	NRSA63J-103X	MG RESISTOR		
	DI400	QLF0084-001	FL TUBE				R 448	NRSA63J-103X	MG RESISTOR		
	IC400	MN101C35DHL1	IC	MASUKU			R 449	NRSA63J-103X	MG RESISTOR		
	IC400	MN101CP35DHL1	IC	ONE TIME			R 450	NRSA63J-103X	MG RESISTOR		
	IC402	BU2092	IC				R 451	NRSA63J-103X	MG RESISTOR		
	IC404	GP1U281X	IC				R 452	NRSA63J-103X	MG RESISTOR		

■ Electrical parts list (Front board)

Block No. 02

△	Item	Parts number	Parts name	Remarks	Area
	R 453	NRSA63J-103X	MG RESISTOR		
	R 454	NRSA63J-103X	MG RESISTOR		
	R 455	NRSA63J-471X	MG RESISTOR		
	R 456	NRSA63J-103X	MG RESISTOR		
	R 457	NRSA63J-103X	MG RESISTOR		
	R 458	NRSA63J-103X	MG RESISTOR		
	R 459	NRSA63J-221X	MG RESISTOR		
	R 460	NRSA63J-221X	MG RESISTOR		
	R 461	NRSA63J-221X	MG RESISTOR		
	R 462	NRSA63J-221X	MG RESISTOR		
	R 463	NRSA63J-221X	MG RESISTOR		
	R 464	NRSA63J-221X	MG RESISTOR		
	R 465	NRSA63J-331X	MG RESISTOR		
	R 466	NRSA63J-331X	MG RESISTOR		
	R 467	NRSA63J-221X	MG RESISTOR		
	R 468	NRSA63J-221X	MG RESISTOR		
	R 469	NRSA63J-221X	MG RESISTOR		
	R 470	NRSA63J-750X	MG RESISTOR		
	R 471	NRSA63J-750X	MG RESISTOR		
	R 472	NRSA63J-750X	MG RESISTOR		
	R 473	NRSA63J-152X	MG RESISTOR		
	R 474	NRSA63J-105X	MG RESISTOR		
	R 475	NRSA63J-220X	MG RESISTOR		
	R 476	NRSA63J-220X	MG RESISTOR		
	R 477	NRSA63J-220X	MG RESISTOR		
	R 479	NRSA63J-181X	MG RESISTOR		
	R 480	NRSA63J-152X	MG RESISTOR		
	R 481	NRSA63J-222X	MG RESISTOR		
	R 482	NRSA63J-272X	MG RESISTOR		
	R 483	NRSA63J-392X	MG RESISTOR		
	R 490	NRSA63J-272X	MG RESISTOR		
	R 491	NRSA63J-392X	MG RESISTOR		
	R 495	QRE141J-102Y	C RESISTOR	1.0K 5% 1/4W	
	S 400	QSW0683-001Z	PUSH SWITCH	(SURROUND)	
	S 401	QSW0683-001Z	PUSH SWITCH	(DSP MODE)	
	S 402	QSW0683-001Z	PUSH SWITCH	(INPUT MODE)	
	S 403	QSW0683-001Z	PUSH SWITCH	(TUNING UP)	
	S 404	QSW0683-001Z	PUSH SWITCH	(PRESET UP)	
	S 405	QSW0683-001Z	PUSH SWITCH	(FM MODE)	
	S 406	QSW0683-001Z	PUSH SWITCH	(MEMORY)	
	S 407	QSW0683-001Z	PUSH SWITCH	(MIDNIGHT MODE)	
	S 408	QSW0683-001Z	PUSH SWITCH	(DVD)	
	S 409	QSW0683-001Z	PUSH SWITCH	(DVD MULTI)	
	S 410	QSW0683-001Z	PUSH SWITCH	(TUNING DOWN)	
	S 411	QSW0683-001Z	PUSH SWITCH	(PRESET DOWN)	
	S 412	QSW0683-001Z	PUSH SWITCH	(VCR1)	
	S 413	QSW0683-001Z	PUSH SWITCH	(VCR2)	
	S 414	QSW0683-001Z	PUSH SWITCH	(VIDEO)	
	S 415	QSW0683-001Z	PUSH SWITCH	(CD)	
	S 416	QSW0683-001Z	PUSH SWITCH	(TV/DBS)	
	S 417	QSW0683-001Z	PUSH SWITCH	(CDR)	
	S 418	QSW0683-001Z	PUSH SWITCH	(USB AUDIO)	
	S 419	QSW0683-001Z	PUSH SWITCH	(PHONE)	
	S 420	QSW0683-001Z	PUSH SWITCH	(FM/AM)	
	S 421	QSW0683-001Z	PUSH SWITCH	(DIGITAL SEA)	
	S 422	QSW0683-001Z	PUSH SWITCH	(LEVEL ADJUST)	
	S 423	QSW0683-001Z	PUSH SWITCH	(TAPE/MD)	
	S 424	QSW0683-001Z	PUSH SWITCH	(DOWN)	
	S 425	QSW0683-001Z	PUSH SWITCH	(EFFECT)	
	S 426	QSW0683-001Z	PUSH SWITCH	(SETTING)	
	S 431	QSW0683-001Z	PUSH SWITCH	(UP)	
	S 480	QSW0683-001Z	PUSH SWITCH	(POWER)	
	S 481	QSW0683-001Z	PUSH SWITCH	(SPK1)	

△	Item	Parts number	Parts name	Remarks	Area
	S 482	QSW0683-001Z	PUSH SWITCH	(SPK2)	
	S 483	QSW0683-001Z	PUSH SWITCH	(SUBWFR)	
	S 490	QSW0683-001Z	PUSH SWITCH	(DIRECT)	
	S 491	QSW0683-001Z	PUSH SWITCH	(BASS)	
	X 400	QAX0246-001Z	RESONATOR		
	X 410	QAX0320-001Z	CRYSTAL		

* When IC400 uses "one time micon", this list is used.

RA400	QRB169J-104	RESISTOR ARRAY	100K 5% 1/6W	
RA401	QRB169J-104	RESISTOR ARRAY	100K 5% 1/6W	
RA402	QRB169J-104	RESISTOR ARRAY	100K 5% 1/6W	
RA403	QRB059J-104	RESISTOR ARRAY	100K 5% 1/5W	

■ Electrical parts list (Power board)

Block No. 03

△	Item	Parts number	Parts name	Remarks	Area	△	Item	Parts number	Parts name	Remarks	Area
	C 701	QTE1V06-106Z	E CAPACITOR				C1808	QETN1CM-107Z	E CAPACITOR	100MF 20% 16V	
	C 702	QTE1V06-106Z	E CAPACITOR				C1809	QCS31HJ-5R0Z	C CAPACITOR	5.0PF 5% 50V	
	C 703	QCS11HJ-101	C CAPACITOR	100PF 5% 50V			C1810	QCS31HJ-5R0Z	C CAPACITOR	5.0PF 5% 50V	
	C 704	QCS11HJ-101	C CAPACITOR	100PF 5% 50V			C1811	QCS32HJ-330Z	C CAPACITOR	33PF 5% 500V	
	C 705	QCS11HJ-101	C CAPACITOR	100PF 5% 50V			C1812	QCS32HJ-330Z	C CAPACITOR	33PF 5% 500V	
	C 706	QCS11HJ-101	C CAPACITOR	100PF 5% 50V			C1813	QFLC1HJ-103Z	M CAPACITOR	.010MF 5% 50V	
	C 707	QETN1CM-107Z	E CAPACITOR	100MF 20% 16V			C1814	QFLC1HJ-103Z	M CAPACITOR	.010MF 5% 50V	
	C 708	QETN1CM-107Z	E CAPACITOR	100MF 20% 16V			C1815	QETN1HM-225Z	E CAPACITOR	2.2MF 20% 50V	
	C 709	QCS11HJ-100	C CAPACITOR	10PF 5% 50V			C1816	QETN1HM-225Z	E CAPACITOR	2.2MF 20% 50V	
	C 710	QCS11HJ-100	C CAPACITOR	10PF 5% 50V			C1817	QETN1HM-476Z	E CAPACITOR	47MF 20% 50V	
	C 711	QFLC1HJ-103Z	M CAPACITOR	.010MF 5% 50V			C1818	QETN1HM-476Z	E CAPACITOR	47MF 20% 50V	
	C 712	QFLC1HJ-103Z	M CAPACITOR	.010MF 5% 50V			C1841	QETN2AM-476Z	E CAPACITOR	47MF 20% 100V	
	C 713	QCS11HJ-680	C CAPACITOR	68PF 5% 50V			C1842	QETN2AM-476Z	E CAPACITOR	47MF 20% 100V	
	C 714	QCS11HJ-680	C CAPACITOR	68PF 5% 50V			C1843	QETN2AM-476Z	E CAPACITOR	47MF 20% 100V	
	C 715	QCS11HJ-680	C CAPACITOR	68PF 5% 50V			C1844	QETN2AM-476Z	E CAPACITOR	47MF 20% 100V	
	C 716	QCS11HJ-680	C CAPACITOR	68PF 5% 50V			C1851	QCS32HJ-470Z	C CAPACITOR	47PF 5% 500V	
	C 717	QCS32HJ-220Z	C CAPACITOR	22PF 5% 500V			C1852	QCS32HJ-470Z	C CAPACITOR	47PF 5% 500V	
	C 718	QCS32HJ-220Z	C CAPACITOR	22PF 5% 500V			C1853	QCS32HJ-470Z	C CAPACITOR	47PF 5% 500V	
	C 719	QFLC1HJ-472Z	M CAPACITOR	4700PF 5% 50V			C1854	QCS32HJ-470Z	C CAPACITOR	47PF 5% 500V	
	C 720	QFLC1HJ-472Z	M CAPACITOR	4700PF 5% 50V			C1861	QFLC1HJ-473Z	M CAPACITOR	.047MF 5% 50V	
	C 741	QETN2AM-476Z	E CAPACITOR	47MF 20% 100V			C1862	QFLC1HJ-473Z	M CAPACITOR	.047MF 5% 50V	
	C 742	QETN2AM-476Z	E CAPACITOR	47MF 20% 100V			C1863	QFLC1HJ-473Z	M CAPACITOR	.047MF 5% 50V	
	C 745	QETN2AM-476Z	E CAPACITOR	47MF 20% 100V			C1864	QFLC1HJ-473Z	M CAPACITOR	.047MF 5% 50V	
	C 746	QETN2AM-476Z	E CAPACITOR	47MF 20% 100V			C1891	QCF31HZ-223Z	C CAPACITOR	.022MF +80:-20%	
	C 751	QCS32HJ-470Z	C CAPACITOR	47PF 5% 500V			C1892	QCF31HZ-223Z	C CAPACITOR	.022MF +80:-20%	
	C 752	QCS32HJ-470Z	C CAPACITOR	47PF 5% 500V			D 701	1SS133-T2	SI DIODE		
	C 753	QCS32HJ-470Z	C CAPACITOR	47PF 5% 500V			D 702	1SS133-T2	SI DIODE		
	C 754	QCS32HJ-470Z	C CAPACITOR	47PF 5% 500V			D 703	1SS133-T2	SI DIODE		
	C 791	QFLC1HJ-473Z	M CAPACITOR	.047MF 5% 50V			D 704	1SS133-T2	SI DIODE		
	C 792	QFLC1HJ-473Z	M CAPACITOR	.047MF 5% 50V			D 771	1SS133-T2	SI DIODE		
	C 793	QFLC1HJ-473Z	M CAPACITOR	.047MF 5% 50V			D 772	1SS133-T2	SI DIODE		
	C 794	QFLC1HJ-473Z	M CAPACITOR	.047MF 5% 50V			D 773	1SS133-T2	SI DIODE		
	C 795	QCF31HZ-223Z	C CAPACITOR	.022MF +80:-20%			D 774	1SS133-T2	SI DIODE		
	C 796	QCF31HZ-223Z	C CAPACITOR	.022MF +80:-20%			D 791	1SS133-T2	SI DIODE		
	CN711	QGB2510K1-14	CONNECTOR				D 792	1SS133-T2	SI DIODE		
	CN712	QGB2510K1-14	CONNECTOR				D1701	1SS133-T2	SI DIODE		
	CN713	QGB2510K1-10	CONNECTOR				D1771	1SS133-T2	SI DIODE		
	CN715	QGB2510K1-12	CONNECTOR				D1772	1SS133-T2	SI DIODE		
	CN716	QGB2510K1-12	CONNECTOR				D1791	1SS133-T2	SI DIODE		
	CN722	QGA2501F1-02	CONNECTOR				D1801	1SS133-T2	SI DIODE		
	C1701	QETN1HM-105Z	E CAPACITOR	1.0MF 20% 50V			D1802	1SS133-T2	SI DIODE		
	C1702	QCS11HJ-101	C CAPACITOR	100PF 5% 50V			D1871	1SS133-T2	SI DIODE		
	C1703	QCS11HJ-101	C CAPACITOR	100PF 5% 50V			D1872	1SS133-T2	SI DIODE		
	C1704	QETN1CM-107Z	E CAPACITOR	100MF 20% 16V			D1873	1SS133-T2	SI DIODE		
	C1705	QCS31HJ-5R0Z	C CAPACITOR	5.0PF 5% 50V			D1874	1SS133-T2	SI DIODE		
	C1711	QCS32HJ-330Z	C CAPACITOR	33PF 5% 500V			D1891	1SS133-T2	SI DIODE		
	C1712	QFLC1HJ-103Z	M CAPACITOR	.010MF 5% 50V			D1892	1SS133-T2	SI DIODE		
	C1713	QETN1HM-225Z	E CAPACITOR	2.2MF 20% 50V			L 791	QQLZ003-1R0	INDUCTOR		
	C1715	QETN1HM-476Z	E CAPACITOR	47MF 20% 50V			L 792	QQLZ003-1R0	INDUCTOR		
	C1741	QETN2AM-476Z	E CAPACITOR	47MF 20% 100V			L1761	QQLZ005-R45	INDUCTOR		
	C1743	QETN2AM-476Z	E CAPACITOR	47MF 20% 100V			L1861	QQLZ005-R45	INDUCTOR		
	C1751	QCS32HJ-470Z	C CAPACITOR	47PF 5% 500V			L1862	QQLZ005-R45	INDUCTOR		
	C1752	QCS32HJ-470Z	C CAPACITOR	47PF 5% 500V			Q 701	2SC2240-BL/AB/T	TRANSISTOR		
	C1761	QFLC1HJ-473Z	M CAPACITOR	.047MF 5% 50V			Q 702	2SC2240-BL/AB/T	TRANSISTOR		
	C1762	QFLC1HJ-473Z	M CAPACITOR	.047MF 5% 50V			Q 703	2SC2240-BL/AB/T	TRANSISTOR		
	C1791	QCF31HZ-223Z	C CAPACITOR	.022MF +80:-20%			Q 704	2SC2240-BL/AB/T	TRANSISTOR		
	C1801	QETN1HM-105Z	E CAPACITOR	1.0MF 20% 50V			Q 705	KTA1268/GL/-T	TRANSISTOR		
	C1802	QETN1HM-105Z	E CAPACITOR	1.0MF 20% 50V			Q 706	KTA1268/GL/-T	TRANSISTOR		
	C1803	QCS11HJ-101	C CAPACITOR	100PF 5% 50V			Q 707	KTA1268/GL/-T	TRANSISTOR		
	C1804	QCS11HJ-101	C CAPACITOR	100PF 5% 50V			Q 708	KTA1268/GL/-T	TRANSISTOR		
	C1805	QCS11HJ-101	C CAPACITOR	100PF 5% 50V			Q 709	KTA1268/GL/-T	TRANSISTOR		
	C1806	QCS11HJ-101	C CAPACITOR	100PF 5% 50V			Q 710	KTA1268/GL/-T	TRANSISTOR		
	C1807	QETN1CM-107Z	E CAPACITOR	100MF 20% 16V			Q 711	KTC3200/GL/-T	TRANSISTOR		

■ Electrical parts list (Power board)

Block No. 03

△	Item	Parts number	Parts name	Remarks	Area	△	Item	Parts number	Parts name	Remarks	Area
	Q 712	KTC3200/GL/-T	TRANSISTOR				R 726	QRE141J-152Y	C RESISTOR	1.5K 5% 1/4W	
△	Q 761	2SD2560/OPY/-F6	TRANSISTOR				R 727	QRE141J-333Y	C RESISTOR	33K 5% 1/4W	
	Q 762	2SD2560/OPY/-F6	TRANSISTOR				R 728	QRE141J-333Y	C RESISTOR	33K 5% 1/4W	
△	Q 763	2SB1647/OPY/-F6	TRANSISTOR				R 729	QRE141J-391Y	C RESISTOR	390 5% 1/4W	
△	Q 764	2SB1647/OPY/-F6	TRANSISTOR				R 730	QRE141J-391Y	C RESISTOR	390 5% 1/4W	
	Q 771	KTC3200/GL/-T	TRANSISTOR				R 731	QRE141J-391Y	C RESISTOR	390 5% 1/4W	
	Q 772	KTC3200/GL/-T	TRANSISTOR				R 732	QRE141J-391Y	C RESISTOR	390 5% 1/4W	
	Q 773	KTA1268/GL/-T	TRANSISTOR				R 733	QRE141J-221Y	C RESISTOR	220 5% 1/4W	
	Q 774	KTA1268/GL/-T	TRANSISTOR				R 734	QRE141J-221Y	C RESISTOR	220 5% 1/4W	
	Q 781	2SD637/QR/	TRANSISTOR				R 761	QRJ146J-100X	UNF C RESISTOR	10 5% 1/4W	
	Q 782	2SD637/QR/	TRANSISTOR				R 762	QRJ146J-100X	UNF C RESISTOR	10 5% 1/4W	
	Q 791	KTA1268/GL/-T	TRANSISTOR				R 763	QRJ146J-100X	UNF C RESISTOR	10 5% 1/4W	
	Q 792	KTA1268/GL/-T	TRANSISTOR				R 764	QRJ146J-100X	UNF C RESISTOR	10 5% 1/4W	
	Q1701	2SC2240-BL/AB/T	TRANSISTOR				R 771	QRE141J-391Y	C RESISTOR	390 5% 1/4W	
	Q1702	2SC2240-BL/AB/T	TRANSISTOR				R 772	QRE141J-391Y	C RESISTOR	390 5% 1/4W	
	Q1703	KTA1268/GL/-T	TRANSISTOR				R 773	QRE141J-391Y	C RESISTOR	390 5% 1/4W	
	Q1731	2SD637/QR/	TRANSISTOR				R 774	QRE141J-391Y	C RESISTOR	390 5% 1/4W	
△	Q1751	2SD2390/OPY/-F6	TRANSISTOR				R 775	QRE141J-201Y	C RESISTOR	200 5% 1/4W	
△	Q1752	2SB1560/OPY/-F6	TRANSISTOR				R 776	QRE141J-201Y	C RESISTOR	200 5% 1/4W	
	Q1771	KTC3200/GL/-T	TRANSISTOR				R 777	QRE141J-201Y	C RESISTOR	200 5% 1/4W	
	Q1772	KTA1268/GL/-T	TRANSISTOR				R 778	QRE141J-201Y	C RESISTOR	200 5% 1/4W	
	Q1791	KTA1268/GL/-T	TRANSISTOR				R 779	QRZ0218-R22	EMIT RESISTOR	1/2W	
	Q1801	2SC2240-BL/AB/T	TRANSISTOR				R 780	QRZ0218-R22	EMIT RESISTOR	1/2W	
	Q1802	2SC2240-BL/AB/T	TRANSISTOR				R 781	QRE141J-391Y	C RESISTOR	390 5% 1/4W	
	Q1803	2SC2240-BL/AB/T	TRANSISTOR				R 782	QRE141J-391Y	C RESISTOR	390 5% 1/4W	
	Q1804	2SC2240-BL/AB/T	TRANSISTOR				R 783	QRE141J-621Y	C RESISTOR	620 5% 1/4W	
	Q1805	KTA1268/GL/-T	TRANSISTOR				R 784	QRE141J-621Y	C RESISTOR	620 5% 1/4W	
	Q1806	KTA1268/GL/-T	TRANSISTOR				R 787	QRE141J-473Y	C RESISTOR	47K 5% 1/4W	
	Q1831	2SD637/QR/	TRANSISTOR				R 788	QRE141J-473Y	C RESISTOR	47K 5% 1/4W	
	Q1832	2SD637/QR/	TRANSISTOR				R 789	QRE141J-471Y	C RESISTOR	470 5% 1/4W	
△	Q1851	2SD2390/OPY/-F6	TRANSISTOR				R 790	QRE141J-471Y	C RESISTOR	470 5% 1/4W	
△	Q1852	2SD2390/OPY/-F6	TRANSISTOR				R 791	QRJ125J-330	UNF C RESISTOR	33 5% 1/2W	
△	Q1853	2SB1560/OPY/-F6	TRANSISTOR				R 792	QRJ125J-330	UNF C RESISTOR	33 5% 1/2W	
△	Q1854	2SB1560/OPY/-F6	TRANSISTOR				R 793	QRL022J-100	UNF OMF RESISTOR	10 5% 1/2W	
	Q1871	KTC3200/GL/-T	TRANSISTOR				R 794	QRL022J-100	UNF OMF RESISTOR	10 5% 1/2W	
	Q1872	KTC3200/GL/-T	TRANSISTOR				R 795	QRE141J-102Y	C RESISTOR	1.0K 5% 1/4W	
	Q1873	KTA1268/GL/-T	TRANSISTOR				R 796	QRE141J-102Y	C RESISTOR	1.0K 5% 1/4W	
	Q1874	KTA1268/GL/-T	TRANSISTOR				R 797	QRE141J-153Y	C RESISTOR	15K 5% 1/4W	
	Q1891	KTA1268/GL/-T	TRANSISTOR				R 798	QRE141J-153Y	C RESISTOR	15K 5% 1/4W	
	Q1892	KTA1268/GL/-T	TRANSISTOR				R1701	QRE141J-222Y	C RESISTOR	2.2K 5% 1/4W	
	R 701	QRE141J-222Y	C RESISTOR	2.2K 5% 1/4W			R1702	QRE141J-683Y	C RESISTOR	68K 5% 1/4W	
	R 702	QRE141J-222Y	C RESISTOR	2.2K 5% 1/4W			R1703	QRE141J-202Y	C RESISTOR	2.0K 5% 1/4W	
	R 703	QRE141J-104Y	C RESISTOR	100K 5% 1/4W			R1705	QRE141J-123Y	C RESISTOR	12K 5% 1/4W	
	R 704	QRE141J-104Y	C RESISTOR	100K 5% 1/4W			R1711	QRE141J-331Y	C RESISTOR	330 5% 1/4W	
	R 705	QRE141J-202Y	C RESISTOR	2.0K 5% 1/4W			R1712	QRE141J-563Y	C RESISTOR	56K 5% 1/4W	
	R 706	QRE141J-202Y	C RESISTOR	2.0K 5% 1/4W			R1721	QRJ146J-221X	UNF C RESISTOR	220 5% 1/4W	
	R 707	QRE141J-202Y	C RESISTOR	2.0K 5% 1/4W			R1722	QRE141J-332Y	C RESISTOR	3.3K 5% 1/4W	
	R 708	QRE141J-202Y	C RESISTOR	2.0K 5% 1/4W			R1723	QRE141J-332Y	C RESISTOR	3.3K 5% 1/4W	
	R 709	QRE141J-912Y	C RESISTOR	9.1K 5% 1/4W			R1724	QRE141J-332Y	C RESISTOR	3.3K 5% 1/4W	
	R 710	QRE141J-912Y	C RESISTOR	9.1K 5% 1/4W			R1725	QRE141J-332Y	C RESISTOR	3.3K 5% 1/4W	
	R 711	QRE141J-621Y	C RESISTOR	620 5% 1/4W			R1731	QRE141J-102Y	C RESISTOR	1.0K 5% 1/4W	
	R 712	QRE141J-621Y	C RESISTOR	620 5% 1/4W			R1732	QRE141J-391Y	C RESISTOR	390 5% 1/4W	
	R 715	QRE141J-104Y	C RESISTOR	100K 5% 1/4W			R1741	QRJ146J-221X	UNF C RESISTOR	220 5% 1/4W	
	R 716	QRE141J-104Y	C RESISTOR	100K 5% 1/4W			R1751	QRJ146J-100X	UNF C RESISTOR	10 5% 1/4W	
	R 717	QRJ146J-562X	UNF C RESISTOR	5.6K 5% 1/4W			R1752	QRJ146J-100X	UNF C RESISTOR	10 5% 1/4W	
	R 718	QRJ146J-562X	UNF C RESISTOR	5.6K 5% 1/4W			R1753	QRZ0218-R22	EMIT RESISTOR	1/2W	
	R 719	QRK126J-103X	UNF C RESISTOR	10K 5% 1/2W			R1761	QRJ125J-330	UNF C RESISTOR	33 5% 1/2W	
	R 720	QRK126J-103X	UNF C RESISTOR	10K 5% 1/2W			R1762	QRL022J-100	UNF OMF RESISTOR	10 5% 1/2W	
	R 721	QRJ146J-151X	UNF C RESISTOR	150 5% 1/4W			R1771	QRE141J-391Y	C RESISTOR	390 5% 1/4W	
	R 722	QRJ146J-151X	UNF C RESISTOR	150 5% 1/4W			R1772	QRE141J-391Y	C RESISTOR	390 5% 1/4W	
	R 723	QRE141J-391Y	C RESISTOR	390 5% 1/4W			R1773	QRE141J-201Y	C RESISTOR	200 5% 1/4W	
	R 724	QRE141J-391Y	C RESISTOR	390 5% 1/4W			R1774	QRE141J-201Y	C RESISTOR	200 5% 1/4W	
	R 725	QRE141J-152Y	C RESISTOR	1.5K 5% 1/4W			R1791	QRE141J-102Y	C RESISTOR	1.0K 5% 1/4W	

■ Electrical parts list (Power board)

Block No. 03

△	Item	Parts number	Parts name	Remarks	Area
	R1793	QRE141J-183Y	C RESISTOR	18K 5% 1/4W	
	R1795	QRE141J-473Y	C RESISTOR	47K 5% 1/4W	
	R1801	QRE141J-222Y	C RESISTOR	2.2K 5% 1/4W	
	R1802	QRE141J-222Y	C RESISTOR	2.2K 5% 1/4W	
	R1803	QRE141J-683Y	C RESISTOR	68K 5% 1/4W	
	R1804	QRE141J-683Y	C RESISTOR	68K 5% 1/4W	
	R1805	QRE141J-202Y	C RESISTOR	2.0K 5% 1/4W	
	R1806	QRE141J-202Y	C RESISTOR	2.0K 5% 1/4W	
	R1809	QRE141J-123Y	C RESISTOR	12K 5% 1/4W	
	R1810	QRE141J-123Y	C RESISTOR	12K 5% 1/4W	
	R1811	QRE141J-331Y	C RESISTOR	330 5% 1/4W	
	R1812	QRE141J-331Y	C RESISTOR	330 5% 1/4W	
	R1813	QRE141J-563Y	C RESISTOR	56K 5% 1/4W	
	R1814	QRE141J-563Y	C RESISTOR	56K 5% 1/4W	
	R1821	QRJ146J-221X	UNF C RESISTOR	220 5% 1/4W	
	R1822	QRJ146J-221X	UNF C RESISTOR	220 5% 1/4W	
	R1823	QRE141J-332Y	C RESISTOR	3.3K 5% 1/4W	
	R1824	QRE141J-332Y	C RESISTOR	3.3K 5% 1/4W	
	R1825	QRE141J-332Y	C RESISTOR	3.3K 5% 1/4W	
	R1826	QRE141J-332Y	C RESISTOR	3.3K 5% 1/4W	
	R1827	QRE141J-332Y	C RESISTOR	3.3K 5% 1/4W	
	R1828	QRE141J-332Y	C RESISTOR	3.3K 5% 1/4W	
	R1829	QRE141J-332Y	C RESISTOR	3.3K 5% 1/4W	
	R1830	QRE141J-332Y	C RESISTOR	3.3K 5% 1/4W	
	R1831	QRE141J-102Y	C RESISTOR	1.0K 5% 1/4W	
	R1832	QRE141J-102Y	C RESISTOR	1.0K 5% 1/4W	
	R1833	QRE141J-391Y	C RESISTOR	390 5% 1/4W	
	R1834	QRE141J-391Y	C RESISTOR	390 5% 1/4W	
	R1841	QRJ146J-221X	UNF C RESISTOR	220 5% 1/4W	
	R1842	QRJ146J-221X	UNF C RESISTOR	220 5% 1/4W	
	R1851	QRJ146J-100X	UNF C RESISTOR	10 5% 1/4W	
	R1852	QRJ146J-100X	UNF C RESISTOR	10 5% 1/4W	
	R1853	QRJ146J-100X	UNF C RESISTOR	10 5% 1/4W	
	R1854	QRJ146J-100X	UNF C RESISTOR	10 5% 1/4W	
	R1855	QRZ0218-R22	EMIT RESISTOR	1/2W	
	R1856	QRZ0218-R22	EMIT RESISTOR	1/2W	
	R1861	QRJ125J-330	UNF C RESISTOR	33 5% 1/2W	
	R1862	QRJ125J-330	UNF C RESISTOR	33 5% 1/2W	
	R1863	QRL022J-100	UNF OMF RESISOR	10 5% 1/2W	
	R1864	QRL022J-100	UNF OMF RESISTOR	10 5% 1/2W	
	R1871	QRE141J-391Y	C RESISTOR	390 5% 1/4W	
	R1872	QRE141J-391Y	C RESISTOR	390 5% 1/4W	
	R1873	QRE141J-391Y	C RESISTOR	390 5% 1/4W	
	R1874	QRE141J-391Y	C RESISTOR	390 5% 1/4W	
	R1875	QRE141J-201Y	C RESISTOR	200 5% 1/4W	
	R1876	QRE141J-201Y	C RESISTOR	200 5% 1/4W	
	R1877	QRE141J-201Y	C RESISTOR	200 5% 1/4W	
	R1878	QRE141J-201Y	C RESISTOR	200 5% 1/4W	
	R1891	QRE141J-102Y	C RESISTOR	1.0K 5% 1/4W	
	R1892	QRE141J-102Y	C RESISTOR	1.0K 5% 1/4W	
	R1893	QRE141J-183Y	C RESISTOR	18K 5% 1/4W	
	R1894	QRE141J-183Y	C RESISTOR	18K 5% 1/4W	
	R1895	QRE141J-473Y	C RESISTOR	47K 5% 1/4W	
	R1896	QRE141J-473Y	C RESISTOR	47K 5% 1/4W	
	TH731	QAD0012-202	THERMISTOR		
	TH783	QAD0012-202	THERMISTOR		
	TH784	QAD0012-202	THERMISTOR		
	TH831	QAD0012-202	THERMISTOR		
	TH832	QAD0012-202	THERMISTOR		
	VR787	QVP0008-501Z	SEMI V RESISTOR		
	VR788	QVP0008-501Z	SEMI V RESISTOR		

■ Electrical parts list (Input board)

Block No. 04

△	Item	Parts number	Parts name	Remarks	Area	△	Item	Parts number	Parts name	Remarks	Area
	C 201	QETN1HM-475Z	E CAPACITOR	4.7MF 20% 50V			C 308	QFLC1HJ-682Z	M CAPACITOR	6800PF 5% 50V	
	C 202	QETN1HM-475Z	E CAPACITOR	4.7MF 20% 50V			C 309	NCS31HJ-101X	C CAPACITOR		
	C 203	QETN0JM-477Z	E CAPACITOR	470MF 20% 6.3V			C 310	NCS31HJ-101X	C CAPACITOR		
	C 204	QETN1HM-475Z	E CAPACITOR	4.7MF 20% 50V			C 311	QETN1HM-475Z	E CAPACITOR	4.7MF 20% 50V	
	C 205	QETN0JM-477Z	E CAPACITOR	470MF 20% 6.3V			C 312	QETN1HM-475Z	E CAPACITOR	4.7MF 20% 50V	
	C 206	QETN1HM-475Z	E CAPACITOR	4.7MF 20% 50V			C 313	QETN1AM-107Z	E CAPACITOR	100MF 20% 10V	
	C 207	QETN0JM-477Z	E CAPACITOR	470MF 20% 6.3V			C 314	QETN1AM-107Z	E CAPACITOR	100MF 20% 10V	
	C 208	QETN1CM-476Z	E CAPACITOR	47MF 20% 16V			C 315	QETN1CM-476Z	E CAPACITOR	47MF 20% 16V	
	C 209	QCF11HZ-103	C CAPACITOR	.010MF +80:-20%			C 316	QETN1CM-476Z	E CAPACITOR	47MF 20% 16V	
	C 210	QETN1HM-475Z	E CAPACITOR	4.7MF 20% 50V			C 321	NCB31HK-221X	C CAPACITOR		
	C 211	QETN1HM-475Z	E CAPACITOR	4.7MF 20% 50V			C 322	NCB31HK-221X	C CAPACITOR		
	C 212	QETN1CM-476Z	E CAPACITOR	47MF 20% 16V			C 333	NCB31HK-391X	C CAPACITOR		
	C 213	QCF11HZ-103	C CAPACITOR	.010MF +80:-20%			C 334	NCB31HK-391X	C CAPACITOR		
	C 214	QETN1HM-475Z	E CAPACITOR	4.7MF 20% 50V			C 335	QETN1EM-226Z	E CAPACITOR	22MF 20% 25V	
	C 215	QETN1HM-475Z	E CAPACITOR	4.7MF 20% 50V			C 336	QETN1EM-226Z	E CAPACITOR	22MF 20% 25V	
	C 216	QDX31EM-473Z	C CAPACITOR				C 339	NCB31HK-561X	C CAPACITOR		
	C 217	QETN1AM-477Z	E CAPACITOR	470MF 20% 10V			C 341	QETN1HM-106Z	E CAPACITOR	10MF 20% 50V	
	C 218	QZ0202-155Z	ML C CAPACITOR	1.5MF			C 342	QETN1HM-106Z	E CAPACITOR	10MF 20% 50V	
	C 219	QDC31HJ-150Z	C CAPACITOR				C 343	QETN1HM-106Z	E CAPACITOR	10MF 20% 50V	
	C 220	QDC31HJ-100Z	C CAPACITOR				C 344	QETN1HM-106Z	E CAPACITOR	10MF 20% 50V	
	C 221	QDC31HJ-470Z	C CAPACITOR				C 361	QETN1HM-475Z	E CAPACITOR	4.7MF 20% 50V	
	C 222	QDC31HJ-270Z	C CAPACITOR				C 362	QETN1HM-475Z	E CAPACITOR	4.7MF 20% 50V	
	C 223	NCB31HK-102X	C CAPACITOR				C 363	QETN1HM-475Z	E CAPACITOR	4.7MF 20% 50V	
	C 224	NCB31HK-271X	C CAPACITOR				C 364	QETN1HM-475Z	E CAPACITOR	4.7MF 20% 50V	
	C 225	NCS31HJ-121X	C CAPACITOR				C 385	QETN1EM-226Z	E CAPACITOR	22MF 20% 25V	
	C 226	NCS31HJ-470X	C CAPACITOR				C 386	QETN1EM-226Z	E CAPACITOR	22MF 20% 25V	
	C 231	QETN1HM-475Z	E CAPACITOR	4.7MF 20% 50V			C 389	NCB31HK-561X	C CAPACITOR		
	C 241	QDX31EM-473Z	C CAPACITOR				C 391	QETN1HM-106Z	E CAPACITOR	10MF 20% 50V	
	C 242	QETN1HM-475Z	E CAPACITOR	4.7MF 20% 50V			C 392	QETN1HM-106Z	E CAPACITOR	10MF 20% 50V	
	C 244	QDX31EM-473Z	C CAPACITOR				C 393	NCB31HK-122X	C CAPACITOR		
	C 245	QETN1HM-475Z	E CAPACITOR	4.7MF 20% 50V			C 394	NCB31HK-122X	C CAPACITOR		
	C 246	QDX31EM-473Z	C CAPACITOR				C 395	NCS31HJ-121X	C CAPACITOR		
	C 247	QETN0JM-477Z	E CAPACITOR	470MF 20% 6.3V			C 396	NCS31HJ-121X	C CAPACITOR		
	C 249	QDX31EM-473Z	C CAPACITOR				C 397	QETN1HM-106Z	E CAPACITOR	10MF 20% 50V	
	C 250	QETN1HM-475Z	E CAPACITOR	4.7MF 20% 50V			C 398	QETN1HM-106Z	E CAPACITOR	10MF 20% 50V	
	C 251	QDX31EM-473Z	C CAPACITOR				CN200	QGB2510K1-11	CONNECTOR		
	C 252	QETN0JM-477Z	E CAPACITOR	470MF 20% 6.3V			CN204	QGB1214K1-08S	CONNECTOR		
	C 253	NCS31HJ-100X	C CAPACITOR				CN205	QGB1214J1-08S	CONNECTOR		
	C 254	QDX31EM-473Z	C CAPACITOR				CN206	QGA2501F1-02	CONNECTOR		
	C 255	QETN1HM-475Z	E CAPACITOR	4.7MF 20% 50V			CN240	QGB2510K1-12	CONNECTOR		
	C 256	QCF11HZ-103	C CAPACITOR	.010MF +80:-20%			CN242	QGB1214K1-10S	CONNECTOR		
	C 257	QETN1CM-476Z	E CAPACITOR	47MF 20% 16V			CN243	QGB1214J1-10S	CONNECTOR		
	C 258	QCF11HZ-103	C CAPACITOR	.010MF +80:-20%			CN244	QGA2501F1-04	CONNECTOR		
	C 259	QETN1CM-476Z	E CAPACITOR	47MF 20% 16V			CN311	QGB2510K1-14	CONNECTOR		
	C 260	QDX31EM-473Z	C CAPACITOR				CN313	QGB2510K1-13	CONNECTOR		
	C 261	QETN1HM-475Z	E CAPACITOR	4.7MF 20% 50V			CN351	QGB1214K1-16S	CONNECTOR		
	C 268	NCS31HJ-470X	C CAPACITOR				CN361	QGB1214J1-16S	CONNECTOR		
	C 269	NCS31HJ-470X	C CAPACITOR				CN371	QGB1214K1-14S	CONNECTOR		
	C 270	NCS31HJ-101X	C CAPACITOR				CN381	QGB1214J1-14S	CONNECTOR		
	C 271	NCS31HJ-101X	C CAPACITOR				CN416	QGA2501F1-06	CONNECTOR		
	C 272	QDX31EM-473Z	C CAPACITOR				CN501	QGB1214J1-12S	CONNECTOR		
	C 273	QDX31EM-473Z	C CAPACITOR				CN731	QJP001-032301	SHI CR C-B WIRE		
	C 274	QETN0JM-477Z	E CAPACITOR	470MF 20% 6.3V			CN732	WJP0026-001A	CONNECTOR		
	C 275	NCS31HJ-470X	C CAPACITOR				C1281	QETN1AM-107Z	E CAPACITOR	100MF 20% 10V	
	C 276	NCS31HJ-470X	C CAPACITOR				C1282	QETN1AM-477Z	E CAPACITOR	470MF 20% 10V	
	C 277	QETN1HM-475Z	E CAPACITOR	4.7MF 20% 50V			C1283	QETN1EM-476Z	E CAPACITOR	47MF 20% 25V	
	C 301	QETN1HM-475Z	E CAPACITOR	4.7MF 20% 50V			C1284	QETN1AM-107Z	E CAPACITOR	100MF 20% 10V	
	C 302	QETN1HM-475Z	E CAPACITOR	4.7MF 20% 50V			C1285	QETN1EM-476Z	E CAPACITOR	47MF 20% 25V	
	C 303	NCS31HJ-101X	C CAPACITOR				C1286	QETN1AM-107Z	E CAPACITOR	100MF 20% 10V	
	C 304	NCS31HJ-101X	C CAPACITOR				C1301	QETN1EM-476Z	E CAPACITOR	47MF 20% 25V	
	C 305	QFLC1HJ-182Z	M CAPACITOR	1800PF 5% 50V			C1302	QETN1EM-476Z	E CAPACITOR	47MF 20% 25V	
	C 306	QFLC1HJ-182Z	M CAPACITOR	1800PF 5% 50V			C1303	NCB31HK-221X	C CAPACITOR		
	C 307	QFLC1HJ-682Z	M CAPACITOR	6800PF 5% 50V			C1305	QETN1EM-476Z	E CAPACITOR	47MF 20% 25V	

■ Electrical parts list (Input board)

Block No. 04

△	Item	Parts number	Parts name	Remarks	Area	△	Item	Parts number	Parts name	Remarks	Area
	C1306	QETN1EM-476Z	E CAPACITOR	47MF 20% 25V			HL203	VYH7653-005	IC HOLDER		
	C1307	QETN1CM-476Z	E CAPACITOR	47MF 20% 16V			IC201	BA7625	IC		
	C1311	QETN1HM-475Z	E CAPACITOR	4.7MF 20% 50V			IC202	NJM2285V-W	IC		
	C1312	QETN1HM-475Z	E CAPACITOR	4.7MF 20% 50V			IC203	MB90088PF-131	IC		
	C1313	QETN1HM-475Z	E CAPACITOR	4.7MF 20% 50V			IC241	BA7626	IC		
	C1314	QETN1HM-475Z	E CAPACITOR	4.7MF 20% 50V			IC242	BA7625	IC		
	C1315	QER61HM-224Z	E CAPACITOR	.22MF 20% 50V			IC301	NJM4580D-D	IC		
	C1316	QER61HM-224Z	E CAPACITOR	.22MF 20% 50V			IC302	TC9164AF-X	IC		
	C1319	NCB31HK-221X	C CAPACITOR				IC303	BA15218F-XE	IC		
	C1321	QETN1HM-475Z	E CAPACITOR	4.7MF 20% 50V			IC304	BA15218F-XE	IC		
	C1322	QETN1HM-475Z	E CAPACITOR	4.7MF 20% 50V			IC371	TC9163AF-X	IC		
	C1323	QETN1HM-475Z	E CAPACITOR	4.7MF 20% 50V			IC372	BA15218F-XE	IC		
	C1324	QETN1HM-475Z	E CAPACITOR	4.7MF 20% 50V			IC380	TC9162AN	IC		
	C1325	QER61HM-224Z	E CAPACITOR	.22MF 20% 50V			IC381	TC9459F-X	IC		
	C1326	QER61HM-224Z	E CAPACITOR	.22MF 20% 50V			IC382	TC9459F-X	IC		
	C1329	NCB31HK-221X	C CAPACITOR				IC383	TC9459F-X	IC		
	C1331	QETN1HM-475Z	E CAPACITOR	4.7MF 20% 50V			IC385	BA15218F-XE	IC		
	C1332	QETN1HM-475Z	E CAPACITOR	4.7MF 20% 50V			IC386	BA15218F-XE	IC		
	C1333	QETN1HM-475Z	E CAPACITOR	4.7MF 20% 50V			IC388	TC74HC4053AF-X	IC		
	C1334	QETN1HM-475Z	E CAPACITOR	4.7MF 20% 50V			IC389	TC74HC4053AF-X	IC		
	C1339	NCB31HK-221X	C CAPACITOR				IC390	MAX4018ESD-X	IC		
	C1341	QETN1HM-475Z	E CAPACITOR	4.7MF 20% 50V			J 201	QNN0078-001	PIN JACK		
	C1342	QETN1HM-475Z	E CAPACITOR	4.7MF 20% 50V			J 202	QNN0011-001	PIN JACK		
	C1343	QETN1EM-476Z	E CAPACITOR	47MF 20% 25V			J 203	QNN0011-001	PIN JACK		
	C1344	QETN1EM-476Z	E CAPACITOR	47MF 20% 25V			J 241	QND0002-001	S-CONNECTOR		
	C1345	NCB31HK-391X	C CAPACITOR				J 242	QND0028-001	DIN CONNECTOR		
	C1361	NCB31HK-391X	C CAPACITOR				J 243	QND0088-001	S JACK		
	C1362	NCB31HK-391X	C CAPACITOR				J 301	QNN0056-001	PIN JACK		
	C1363	QETN1HM-475Z	E CAPACITOR	4.7MF 20% 50V			J 302	QNN0056-001	PIN JACK		
	C1364	QETN1HM-475Z	E CAPACITOR	4.7MF 20% 50V			J 303	QNN0058-001	PIN JACK		
	C1365	QETN1HM-475Z	E CAPACITOR	4.7MF 20% 50V			J 371	QNN0056-001	PIN JACK		
	C1366	QETN1HM-475Z	E CAPACITOR	4.7MF 20% 50V			J 372	QNN0056-001	PIN JACK		
	C1370	NCB31HK-221X	C CAPACITOR				J 373	QNN0056-001	PIN JACK		
	C1371	NCB31HK-221X	C CAPACITOR				J1340	QNN0060-001	PIN JACK		
	C1372	NCB31HK-221X	C CAPACITOR				J1360	QNN0390-001	PIN JACK		
	C1375	QCF11HZ-103	C CAPACITOR	.010MF +80:-20%			J1370	QNS0083-001	3.5 JACK		
	C1376	QETN1EM-476Z	E CAPACITOR	47MF 20% 25V			J1371	QNS0077-001	3.5 JACK		
	C1377	QCF11HZ-103	C CAPACITOR	.010MF +80:-20%			J1372	QNS0083-001	3.5 JACK		
	C1378	QETN1EM-476Z	E CAPACITOR	47MF 20% 25V			J1380	QNN0391-001	PIN JACK		
	C1380	QETN1EM-476Z	E CAPACITOR	47MF 20% 25V			L 200	NQL085J-220X	INDUCTOR		
	C1381	NCS31HJ-470X	C CAPACITOR				Q 200	KTA1267/YG/-T	TRANSISTOR		
	C1382	NCS31HJ-470X	C CAPACITOR				Q 201	KTA1267/YG/-T	TRANSISTOR		
	C1383	NCS31HJ-470X	C CAPACITOR				Q 202	KRC110M-T	TRANSISTOR		
	C1384	QETN1EM-476Z	E CAPACITOR	47MF 20% 25V			Q 203	KRC107M-T	D TRANSISTOR		
	C1385	QETN1HM-475Z	E CAPACITOR	4.7MF 20% 50V			Q 204	KTA1267/YG/-T	TRANSISTOR		
	C1386	QETN1HM-475Z	E CAPACITOR	4.7MF 20% 50V			Q 205	KTA1267/YG/-T	TRANSISTOR		
	C1387	NCS31HJ-470X	C CAPACITOR				Q 206	KTA1267/YG/-T	TRANSISTOR		
	C1388	NCS31HJ-470X	C CAPACITOR				Q 207	KTA1267/YG/-T	TRANSISTOR		
	C1389	NCS31HJ-470X	C CAPACITOR				Q 208	DTC123YSA-T	D TRANSISTOR		
	C1390	QETN1EM-476Z	E CAPACITOR	47MF 20% 25V			Q 240	KTA1267/YG/-T	TRANSISTOR		
	C1391	QETN1HM-475Z	E CAPACITOR	4.7MF 20% 50V			Q 241	KTA1267/YG/-T	TRANSISTOR		
	C1392	QETN1HM-475Z	E CAPACITOR	4.7MF 20% 50V			Q 242	KTA1267/YG/-T	TRANSISTOR		
	C1393	NCS31HJ-101X	C CAPACITOR				Q 243	KTA1267/YG/-T	TRANSISTOR		
	C1394	NCS31HJ-101X	C CAPACITOR				Q 244	KRC110M-T	TRANSISTOR		
	C1395	NCS31HJ-101X	C CAPACITOR				Q 245	KRC110M-T	TRANSISTOR		
	C1396	QETN0JM-477Z	E CAPACITOR	470MF 20% 6.3V			Q 246	KRC107M-T	D TRANSISTOR		
	C1397	QETN1AM-107Z	E CAPACITOR	100MF 20% 10V			Q 247	KRC107M-T	D TRANSISTOR		
	C1398	QETN1AM-107Z	E CAPACITOR	100MF 20% 10V			Q1307	KRA104M-T	D TRANSISTOR		
	D 200	1SS133-T1	SI DIODE				Q1313	2SC3576-JVC-T	TRANSISTOR		
	D 201	1SS133-T1	SI DIODE				Q1314	2SC3576-JVC-T	TRANSISTOR		
	D 240	1SS133-T1	SI DIODE				Q1323	2SC3576-JVC-T	TRANSISTOR		
	D 241	1SS133-T1	SI DIODE				Q1333	2SC3576-JVC-T	TRANSISTOR		
	D1370	MA3062/H/-X	ZENER DIODE				Q1334	2SC3576-JVC-T	TRANSISTOR		

■ Electrical parts list (Input board)

Block No. 04

△	Item	Parts number	Parts name	Remarks	Area	△	Item	Parts number	Parts name	Remarks	Area
	Q1341	2SC3576-JVC-T	TRANSISTOR				R 302	NRSA63J-222X	MG RESISTOR		
	Q1342	2SC3576-JVC-T	TRANSISTOR				R 303	NRSA63J-473X	MG RESISTOR		
	Q1343	KRA104M-T	D TRANSISTOR				R 304	NRSA63J-473X	MG RESISTOR		
	R 200	NRSA63J-750X	MG RESISTOR				R 305	NRSA63J-621X	MG RESISTOR		
	R 201	NRSA63J-750X	MG RESISTOR				R 306	NRSA63J-621X	MG RESISTOR		
	R 202	NRSA63J-750X	MG RESISTOR				R 307	NRSA63J-393X	MG RESISTOR		
	R 203	NRSA63J-750X	MG RESISTOR				R 308	NRSA63J-393X	MG RESISTOR		
	R 204	NRSA63J-750X	MG RESISTOR				R 309	NRSA63J-474X	MG RESISTOR		
	R 205	NRSA63J-750X	MG RESISTOR				R 310	NRSA63J-474X	MG RESISTOR		
	R 206	NRSA63J-750X	MG RESISTOR				R 311	NRSA63J-104X	MG RESISTOR		
	R 207	NRSA63J-331X	MG RESISTOR				R 312	NRSA63J-104X	MG RESISTOR		
	R 208	NRSA63J-331X	MG RESISTOR			△	R 315	QRJ146J-331X	UNF C RESISTOR	330 5% 1/4W	
	R 209	NRSA63J-473X	MG RESISTOR			△	R 316	QRJ146J-331X	UNF C RESISTOR	330 5% 1/4W	
	R 210	NRSA63J-331X	MG RESISTOR				R 323	NRSA63J-471X	MG RESISTOR		
	R 211	NRSA63J-473X	MG RESISTOR				R 324	NRSA63J-471X	MG RESISTOR		
	R 212	NRSA63J-331X	MG RESISTOR				R 325	NRSA63J-471X	MG RESISTOR		
	R 213	NRSA63J-473X	MG RESISTOR				R 326	NRSA63J-471X	MG RESISTOR		
	R 214	NRSA63J-151X	MG RESISTOR				R 327	NRSA63J-471X	MG RESISTOR		
	R 215	NRSA63J-151X	MG RESISTOR				R 328	NRSA63J-471X	MG RESISTOR		
	R 216	NRSA63J-301X	MG RESISTOR				R 329	NRSA63J-471X	MG RESISTOR		
	R 217	NRSA63J-103X	MG RESISTOR				R 330	NRSA63J-471X	MG RESISTOR		
	R 218	NRSA63J-331X	MG RESISTOR				R 331	NRSA63J-471X	MG RESISTOR		
	R 219	NRSA63J-101X	MG RESISTOR				R 332	NRSA63J-471X	MG RESISTOR		
	R 220	NRSA63J-151X	MG RESISTOR				R 333	NRSA63J-471X	MG RESISTOR		
	R 221	NRSA63J-151X	MG RESISTOR				R 334	NRSA63J-471X	MG RESISTOR		
	R 222	NRSA63J-561X	MG RESISTOR			△	R 335	QRZ9005-680X	F RESISTOR	68 1/0W	
	R 223	NRSA63J-561X	MG RESISTOR			△	R 336	QRZ9005-680X	F RESISTOR	68 1/0W	
	R 224	NRSA63J-561X	MG RESISTOR				R 341	NRSA63J-104X	MG RESISTOR		
△	R 225	QRJ146J-2R2X	UNF C RESISTOR	2.2 5% 1/4W			R 342	NRSA63J-104X	MG RESISTOR		
	R 231	NRSA63J-222X	MG RESISTOR				R 343	NRSA63J-104X	MG RESISTOR		
	R 232	NRSA63J-470X	MG RESISTOR				R 344	NRSA63J-104X	MG RESISTOR		
	R 240	NRSA63J-750X	MG RESISTOR				R 345	NRSA63J-104X	MG RESISTOR		
	R 241	NRSA63J-750X	MG RESISTOR				R 346	NRSA63J-104X	MG RESISTOR		
	R 242	NRSA63J-750X	MG RESISTOR				R 361	NRSA63J-104X	MG RESISTOR		
	R 243	NRSA63J-750X	MG RESISTOR				R 362	NRSA63J-104X	MG RESISTOR		
	R 244	NRSA63J-750X	MG RESISTOR				R 363	NRSA63J-104X	MG RESISTOR		
	R 245	NRSA63J-750X	MG RESISTOR				R 364	NRSA63J-104X	MG RESISTOR		
	R 246	NRSA63J-750X	MG RESISTOR				R 365	NRSA63J-104X	MG RESISTOR		
	R 247	NRSA63J-750X	MG RESISTOR				R 366	NRSA63J-104X	MG RESISTOR		
	R 248	NRSA63J-151X	MG RESISTOR				R 371	NRSA63J-471X	MG RESISTOR		
	R 249	NRSA63J-151X	MG RESISTOR				R 372	NRSA63J-471X	MG RESISTOR		
	R 250	NRSA63J-151X	MG RESISTOR				R 373	NRSA63J-471X	MG RESISTOR		
	R 251	NRSA63J-151X	MG RESISTOR				R 374	NRSA63J-471X	MG RESISTOR		
	R 253	NRSA63J-153X	MG RESISTOR				R 375	NRSA63J-471X	MG RESISTOR		
	R 254	NRSA63J-153X	MG RESISTOR				R 376	NRSA63J-471X	MG RESISTOR		
	R 255	NRSA63J-153X	MG RESISTOR				R 377	NRSA63J-471X	MG RESISTOR		
	R 266	NRSA63J-750X	MG RESISTOR				R 378	NRSA63J-471X	MG RESISTOR		
	R 267	NRSA63J-473X	MG RESISTOR				R 379	NRSA63J-471X	MG RESISTOR		
	R 268	NRSA63J-750X	MG RESISTOR				R 380	NRSA63J-471X	MG RESISTOR		
	R 269	NRSA63J-473X	MG RESISTOR				R 381	NRSA63J-471X	MG RESISTOR		
△	R 271	QRJ146J-3R3X	UNF C RESISTOR	3.3 5% 1/4W			R 382	NRSA63J-471X	MG RESISTOR		
	R 272	NRSA63J-750X	MG RESISTOR			△	R 385	QRZ9005-680X	F RESISTOR	68 1/0W	
	R 273	NRSA63J-473X	MG RESISTOR			△	R 386	QRZ9005-680X	F RESISTOR	68 1/0W	
	R 274	NRSA63J-750X	MG RESISTOR				R 387	NRSA63J-471X	MG RESISTOR		
	R 275	NRSA63J-750X	MG RESISTOR				R 388	NRSA63J-471X	MG RESISTOR		
	R 276	NRSA63J-750X	MG RESISTOR				R 389	NRSA63J-471X	MG RESISTOR		
	R 280	NRSA63J-301X	MG RESISTOR				R 390	NRSA63J-471X	MG RESISTOR		
	R 281	NRSA63J-301X	MG RESISTOR				R 391	NRSA63J-512X	MG RESISTOR		
	R 282	NRSA63J-103X	MG RESISTOR				R 392	NRSA63J-512X	MG RESISTOR		
	R 283	NRSA63J-103X	MG RESISTOR				R 393	NRSA63J-103X	MG RESISTOR		
	R 284	NRSA63J-301X	MG RESISTOR				R 394	NRSA63J-103X	MG RESISTOR		
	R 285	NRSA63J-301X	MG RESISTOR				R 395	NRSA63J-512X	MG RESISTOR		
	R 301	NRSA63J-222X	MG RESISTOR				R 396	NRSA63J-512X	MG RESISTOR		

■ Electrical parts list (Input board)

Block No. 04

△	Item	Parts number	Parts name	Remarks	Area
	R 397	NRSA63J-104X	MG RESISTOR		
	R 398	NRSA63J-104X	MG RESISTOR		
	R1281	NRSA63J-472X	MG RESISTOR		
	R1282	NRSA63J-472X	MG RESISTOR		
	R1283	NRSA63J-102X	MG RESISTOR		
	R1284	NRSA63J-112X	MG RESISTOR		
	R1285	NRSA63J-472X	MG RESISTOR		
	R1286	NRSA63J-472X	MG RESISTOR		
	R1287	NRSA63J-102X	MG RESISTOR		
	R1288	NRSA63J-112X	MG RESISTOR		
	R1289	NRSA63J-472X	MG RESISTOR		
	R1290	NRSA63J-472X	MG RESISTOR		
	R1291	NRSA63J-102X	MG RESISTOR		
	R1292	NRSA63J-112X	MG RESISTOR		
	R1293	NRSA63J-162X	MG RESISTOR		
	R1294	NRSA63J-472X	MG RESISTOR		
△	R1301	QRZ9005-680X	F RESISTOR	68 1/0W	
△	R1302	QRZ9005-680X	F RESISTOR	68 1/0W	
	R1303	NRSA63J-122X	MG RESISTOR		
	R1304	NRSA63J-122X	MG RESISTOR		
△	R1305	QRZ9005-680X	F RESISTOR	68 1/0W	
△	R1306	QRZ9005-680X	F RESISTOR	68 1/0W	
	R1307	NRSA63J-102X	MG RESISTOR		
	R1311	NRSA63J-104X	MG RESISTOR		
	R1312	NRSA63J-104X	MG RESISTOR		
	R1313	NRSA63J-102X	MG RESISTOR		
	R1314	NRSA63J-103X	MG RESISTOR		
	R1315	NRSA63J-103X	MG RESISTOR		
	R1316	NRSA63J-102X	MG RESISTOR		
	R1321	NRSA63J-104X	MG RESISTOR		
	R1322	NRSA63J-104X	MG RESISTOR		
	R1323	NRSA63J-102X	MG RESISTOR		
	R1324	NRSA63J-103X	MG RESISTOR		
	R1329	NRSA63J-0R0X	MG RESISTOR		
	R1330	NRSA63J-0R0X	MG RESISTOR		
	R1331	NRSA63J-104X	MG RESISTOR		
	R1332	NRSA63J-104X	MG RESISTOR		
	R1333	NRSA63J-102X	MG RESISTOR		
	R1334	NRSA63J-103X	MG RESISTOR		
	R1335	NRSA63J-103X	MG RESISTOR		
	R1336	NRSA63J-102X	MG RESISTOR		
	R1341	NRSA63J-104X	MG RESISTOR		
	R1342	NRSA63J-102X	MG RESISTOR		
	R1343	NRSA63J-183X	MG RESISTOR		
	R1344	NRSA63J-104X	MG RESISTOR		
	R1345	NRSA63J-471X	MG RESISTOR		
	R1346	NRSA63J-103X	MG RESISTOR		
	R1347	NRSA63J-471X	MG RESISTOR		
	R1348	NRSA63J-103X	MG RESISTOR		
	R1349	NRSA63J-474X	MG RESISTOR		
△	R1350	QRZ9005-680X	F RESISTOR	68 1/0W	
△	R1351	QRZ9005-680X	F RESISTOR	68 1/0W	
	R1355	NRSA63J-222X	MG RESISTOR		
	R1356	NRSA63J-222X	MG RESISTOR		
	R1357	NRSA63J-392X	MG RESISTOR		
	R1358	NRSA63J-392X	MG RESISTOR		
	R1361	NRSA63J-561X	MG RESISTOR		
	R1362	NRSA63J-561X	MG RESISTOR		
	R1363	NRSA63J-104X	MG RESISTOR		
	R1364	NRSA63J-104X	MG RESISTOR		
	R1365	NRSA63J-104X	MG RESISTOR		
	R1366	NRSA63J-104X	MG RESISTOR		
	R1367	NRSA63J-104X	MG RESISTOR		

△	Item	Parts number	Parts name	Remarks	Area
	R1368	NRSA63J-104X	MG RESISTOR		
	R1370	NRSA63J-471X	MG RESISTOR		
	R1371	NRSA63J-221X	MG RESISTOR		
	R1372	NRSA63J-101X	MG RESISTOR		
	R1373	NRSA63J-221X	MG RESISTOR		
	R1374	NRSA63J-221X	MG RESISTOR		
	R1375	NRSA63J-221X	MG RESISTOR		
	R1379	NRSA63J-750X	MG RESISTOR		
	R1380	NRSA63J-750X	MG RESISTOR		
	R1381	NRSA63J-750X	MG RESISTOR		
	R1382	NRSA63J-750X	MG RESISTOR		
	R1383	NRSA63J-750X	MG RESISTOR		
	R1384	NRSA63J-750X	MG RESISTOR		
	R1385	NRSA63J-750X	MG RESISTOR		
	R1386	NRSA63J-750X	MG RESISTOR		
	R1387	NRSA63J-750X	MG RESISTOR		
	R1388	NRSA63J-473X	MG RESISTOR		
	R1389	NRSA63J-473X	MG RESISTOR		
	R1390	NRSA63J-473X	MG RESISTOR		
	X 200	QAX0260-001Z	CRYSTAL		

■ Electrical parts list (DSP board)

Block No. 05

▲	Item	Parts number	Parts name	Remarks	Area	▲	Item	Parts number	Parts name	Remarks	Area
	C 571	NCB31HK-103X	C CAPACITOR				C2308	NEA71EM-475X	E CAPACITOR		
	C 573	NCF31CZ-104X	C CAPACITOR				C2347	NCS31HJ-330X	C CAPACITOR		
	C 577	NCS31HJ-101X	C CAPACITOR				C2348	NCS31HJ-330X	C CAPACITOR		
	C 579	NCS31HJ-101X	C CAPACITOR				C2349	NCF31CZ-104X	C CAPACITOR		
	C 581	NEA71CM-106X	E CAPACITOR				C2350	NCF31CZ-104X	C CAPACITOR		
	C 582	NEA71CM-106X	E CAPACITOR				C2351	NEA71HM-105X	E CAPACITOR		
	C 583	NEA70JM-476X	E CAPACITOR				C2352	NEA71HM-105X	E CAPACITOR		
	C 584	NCB31CK-104X	C CAPACITOR				C2353	NCS31HJ-330X	C CAPACITOR		
	C 587	NCF31CZ-104X	C CAPACITOR				C2354	NCS31HJ-330X	C CAPACITOR		
	C 588	NEA70JM-476X	E CAPACITOR				C2355	NCF31CZ-104X	C CAPACITOR		
	C 589	NCF31CZ-104X	C CAPACITOR				C2356	NCF31CZ-104X	C CAPACITOR		
	C 590	NEA70GM-107X	E CAPACITOR				C2357	NEA71EM-475X	E CAPACITOR		
	CN581	QGB1214K3-12W	CONNECTOR				C2358	NEA71EM-475X	E CAPACITOR		
	CN587	QGB2510K1-07	CONNECTOR				C2401	NCB31HK-102X	C CAPACITOR		
	C2001	NEA71EM-475X	E CAPACITOR				C2407	NEA71EM-475X	E CAPACITOR		
	C2002	NEA71EM-475X	E CAPACITOR				C2427	NEA71HM-225X	E CAPACITOR		
	C2003	NCB31HK-122X	C CAPACITOR				C2433	NCS31HJ-330X	C CAPACITOR		
	C2004	NCB31HK-122X	C CAPACITOR				C2439	NCF31CZ-104X	C CAPACITOR		
	C2005	NCS31HJ-121X	C CAPACITOR				C2440	NCF31CZ-104X	C CAPACITOR		
	C2006	NCS31HJ-121X	C CAPACITOR				C2441	NCF31CZ-104X	C CAPACITOR		
	C2007	NCS31HJ-391X	C CAPACITOR				C2442	NCF31CZ-104X	C CAPACITOR		
	C2008	NCS31HJ-391X	C CAPACITOR				C2481	NEA70JM-476X	E CAPACITOR		
	C2009	NCF31CZ-104X	C CAPACITOR				C2501	NCB31HK-103X	C CAPACITOR		
	C2010	NCF31CZ-104X	C CAPACITOR				C2502	NCB31HK-103X	C CAPACITOR		
	C2013	NCS31HJ-330X	C CAPACITOR				C2503	NCB31HK-103X	C CAPACITOR		
	C2014	NCS31HJ-330X	C CAPACITOR				C2504	NCB31HK-103X	C CAPACITOR		
	C2018	NEA70JM-476X	E CAPACITOR				C2505	NCB31HK-103X	C CAPACITOR		
	C2019	NCF31CZ-104X	C CAPACITOR				C2506	NCB31HK-103X	C CAPACITOR		
	C2020	NCF31CZ-104X	C CAPACITOR				C2507	NCB31HK-103X	C CAPACITOR		
	C2101	NCB31HK-103X	C CAPACITOR				C2508	NCB31HK-103X	C CAPACITOR		
	C2107	NEA71EM-475X	E CAPACITOR				C2509	NCB31HK-103X	C CAPACITOR		
	C2133	NCB31EK-223X	C CAPACITOR				C2510	NCB31HK-103X	C CAPACITOR		
	C2134	NCB31EK-223X	C CAPACITOR				C2511	NCB31HK-103X	C CAPACITOR		
	C2135	NEA71CM-106X	E CAPACITOR				C2512	NCB31HK-103X	C CAPACITOR		
	C2136	NEA71CM-106X	E CAPACITOR				C2513	NCB31HK-103X	C CAPACITOR		
	C2137	NEA71EM-475X	E CAPACITOR				C2514	NCB31HK-103X	C CAPACITOR		
	C2138	NEA71EM-475X	E CAPACITOR				C2515	NCB31HK-103X	C CAPACITOR		
	C2157	NEA71HM-225X	E CAPACITOR				C2516	NCB31HK-103X	C CAPACITOR		
	C2158	NCS31HJ-330X	C CAPACITOR				C2517	NCB31HK-103X	C CAPACITOR		
	C2187	NEA71HM-225X	E CAPACITOR				C2518	NCB31HK-103X	C CAPACITOR		
	C2189	NCS31HJ-330X	C CAPACITOR				C2519	NCB31HK-103X	C CAPACITOR		
	C2201	NCB31HK-102X	C CAPACITOR				C2520	NCB31HK-103X	C CAPACITOR		
	C2202	NCB31HK-102X	C CAPACITOR				C2521	NCB31HK-103X	C CAPACITOR		
	C2207	NEA71HM-225X	E CAPACITOR				C2522	NCB31HK-103X	C CAPACITOR		
	C2208	NEA71HM-225X	E CAPACITOR				C2523	NCF31CZ-104X	C CAPACITOR		
	C2230	NEA71EM-475X	E CAPACITOR				C2529	NEA70GM-107X	E CAPACITOR		
	C2237	NCS31HJ-330X	C CAPACITOR				C2532	NEA70GM-107X	E CAPACITOR		
	C2238	NCS31HJ-330X	C CAPACITOR				C2533	NCF31CZ-104X	C CAPACITOR		
	C2251	NCF31CZ-104X	C CAPACITOR				C2534	NCF31CZ-104X	C CAPACITOR		
	C2252	NCF31CZ-104X	C CAPACITOR				C2535	NEA70GM-107X	E CAPACITOR		
	C2253	NCF31CZ-104X	C CAPACITOR				C2536	NCF31CZ-104X	C CAPACITOR		
	C2254	NCF31CZ-104X	C CAPACITOR				C2551	NCS31HJ-270X	C CAPACITOR		
	C2255	NCF31CZ-104X	C CAPACITOR				C2552	NCS31HJ-270X	C CAPACITOR		
	C2256	NCF31CZ-104X	C CAPACITOR				C2553	NEA70GM-107X	E CAPACITOR		
	C2257	NEA71HM-225X	E CAPACITOR				C2555	NCF31CZ-104X	C CAPACITOR		
	C2258	NEA71HM-225X	E CAPACITOR				C2556	NCF31CZ-104X	C CAPACITOR		
	C2261	NEA71EM-475X	E CAPACITOR				C2557	NCS31HJ-330X	C CAPACITOR		
	C2262	NEA71EM-475X	E CAPACITOR				C2560	NCF31CZ-104X	C CAPACITOR		
	C2283	NCS31HJ-330X	C CAPACITOR				C2561	NCF31CZ-104X	C CAPACITOR		
	C2284	NCS31HJ-330X	C CAPACITOR				C2562	NCF31CZ-104X	C CAPACITOR		
	C2301	NCB31HK-102X	C CAPACITOR				C2563	NCF31CZ-104X	C CAPACITOR		
	C2302	NCB31HK-102X	C CAPACITOR				C2564	NCS31HJ-101X	C CAPACITOR		
	C2307	NEA71EM-475X	E CAPACITOR				C2568	NEA71HM-105X	E CAPACITOR		

■ Electrical parts list (DSP board)

Block No. 05

▲	Item	Parts number	Parts name	Remarks	Area	▲	Item	Parts number	Parts name	Remarks	Area
	C2601	NCB31CK-104X	C CAPACITOR				R 574	NRSA63J-432X	MG RESISTOR		
	C2605	NCB31CK-104X	C CAPACITOR				R 575	NRSA63J-432X	MG RESISTOR		
	C2701	NCB31HK-221X	C CAPACITOR				R 576	NRSA63J-432X	MG RESISTOR		
	C2702	NCB31HK-221X	C CAPACITOR				R 577	NRSA63J-822X	MG RESISTOR		
	C2703	NEA70JM-476X	E CAPACITOR				R 578	NRSA63J-822X	MG RESISTOR		
	C2704	NEA70JM-476X	E CAPACITOR				R 579	NRSA63J-822X	MG RESISTOR		
	C2705	NCF31CZ-104X	C CAPACITOR				R 580	NRSA63J-822X	MG RESISTOR		
	C2706	NCF31CZ-104X	C CAPACITOR				R 582	NRSA63J-103X	MG RESISTOR		
	C2707	NCB31CK-104X	C CAPACITOR				R2001	NRSA63J-104X	MG RESISTOR		
	C2710	NEA70JM-476X	E CAPACITOR				R2002	NRSA63J-104X	MG RESISTOR		
	C2712	NCF31CZ-104X	C CAPACITOR				R2003	NRSA63J-103X	MG RESISTOR		
	EP561	E409182-001SM	GRAND TERMINAL				R2004	NRSA63J-103X	MG RESISTOR		
	IC501	XCA56367PV150	IC				R2005	NRSA63J-103X	MG RESISTOR		
	IC502	TC7S04FU-X	IC				R2006	NRSA63J-103X	MG RESISTOR		
	IC503	TC7S04FU-X	IC				R2007	NRSA63J-103X	MG RESISTOR		
	IC505	PQ070XZ1HZ-X	IC				R2008	NRSA63J-103X	MG RESISTOR		
	IC511	W24L010AJ-12-X	IC				R2009	NRSA63J-103X	MG RESISTOR		
	IC521	BA15218F-XE	IC				R2010	NRSA63J-103X	MG RESISTOR		
	IC522	BA15218F-XE	IC				R2011	NRSA63J-223X	MG RESISTOR		
	IC523	BA15218F-XE	IC				R2012	NRSA63J-223X	MG RESISTOR		
	IC524	BA15218F-XE	IC				R2013	NRSA63J-223X	MG RESISTOR		
	IC525	BA15218F-XE	IC				R2014	NRSA63J-223X	MG RESISTOR		
	IC526	BA15218F-XE	IC				R2017	NRSA63J-472X	MG RESISTOR		
	IC527	BA15218F-XE	IC				R2018	NRSA63J-472X	MG RESISTOR		
	IC528	BA15218F-XE	IC				R2021	NRSA63J-331X	MG RESISTOR		
	IC529	BA15218F-XE	IC				R2022	NRSA63J-331X	MG RESISTOR		
	IC551	AK4112AVF-X	IC				R2023	NRSA63J-331X	MG RESISTOR		
	IC571	AK4527BVQ	IC				R2024	NRSA63J-331X	MG RESISTOR		
	IC581	UPD784215AGC132	IC				R2101	NRSA63J-103X	MG RESISTOR		
	IC582	TC7SET32FU-X	IC				R2105	NRSA63J-102X	MG RESISTOR		
	IC583	PQ3DZ53-X	IC				R2107	NRSA63J-104X	MG RESISTOR		
	J 564	QNN0347-001	PIN JACK				R2127	NRSA63J-223X	MG RESISTOR		
	K2606	NQR0269-004X	FERRITE BEADS				R2128	NRSA63J-223X	MG RESISTOR		
	K2607	NQR0269-004X	FERRITE BEADS				R2129	NRSA63J-223X	MG RESISTOR		
	LC501	NQR0322-001X	EMI FILTER				R2130	NRSA63J-104X	MG RESISTOR		
	LC502	NQR0322-001X	EMI FILTER				R2131	NRSA63J-104X	MG RESISTOR		
	LC503	NQR0322-001X	EMI FILTER				R2132	NRSA63J-103X	MG RESISTOR		
	LC551	NQR0322-001X	EMI FILTER				R2133	NRSA63J-102X	MG RESISTOR		
	Q 570	DTC114YE-X	TRANSISTOR				R2134	NRSA63J-103X	MG RESISTOR		
	Q 572	DTC114YE-X	TRANSISTOR				R2135	NRSA63J-222X	MG RESISTOR		
	Q2101	2SD1328/ST/-X	TRANSISTOR				R2136	NRSA63J-103X	MG RESISTOR		
	Q2151	DTA114YE-X	TRANSISTOR				R2137	NRSA63J-103X	MG RESISTOR		
	Q2152	DTA114YE-X	TRANSISTOR				R2138	NRSA63J-223X	MG RESISTOR		
	Q2153	DTA114YE-X	TRANSISTOR				R2139	NRSA63J-103X	MG RESISTOR		
	Q2154	DTA114YE-X	TRANSISTOR				R2140	NRSA63J-105X	MG RESISTOR		
	Q2155	DTA114YE-X	TRANSISTOR				R2157	NRSA63J-104X	MG RESISTOR		
	Q2156	DTA114YE-X	TRANSISTOR				R2158	NRSA63J-303X	MG RESISTOR		
	Q2157	DTA114YE-X	TRANSISTOR				R2159	NRSA63J-113X	MG RESISTOR		
	Q2163	2SD1328/ST/-X	TRANSISTOR				R2171	NRSA63J-105X	MG RESISTOR		
	Q2164	2SD1328/ST/-X	TRANSISTOR				R2172	NRSA63J-105X	MG RESISTOR		
	Q2165	2SD1328/ST/-X	TRANSISTOR				R2181	NRSA63J-105X	MG RESISTOR		
	Q2201	2SD1328/ST/-X	TRANSISTOR				R2182	NRSA63J-105X	MG RESISTOR		
	Q2202	2SD1328/ST/-X	TRANSISTOR				R2183	NRSA63J-105X	MG RESISTOR		
	Q2273	2SD1328/ST/-X	TRANSISTOR				R2184	NRSA63J-105X	MG RESISTOR		
	Q2274	2SD1328/ST/-X	TRANSISTOR				R2186	NRSA63J-105X	MG RESISTOR		
	Q2301	2SD1328/ST/-X	TRANSISTOR				R2187	NRSA63J-104X	MG RESISTOR		
	Q2302	2SD1328/ST/-X	TRANSISTOR				R2189	NRSA63J-223X	MG RESISTOR		
	Q2363	2SD1328/ST/-X	TRANSISTOR				R2201	NRSA63J-103X	MG RESISTOR		
	Q2364	2SD1328/ST/-X	TRANSISTOR				R2202	NRSA63J-103X	MG RESISTOR		
	Q2401	2SD1328/ST/-X	TRANSISTOR				R2205	NRSA63J-102X	MG RESISTOR		
	Q2431	2SD1328/ST/-X	TRANSISTOR				R2206	NRSA63J-102X	MG RESISTOR		
	R 570	NRSA63J-103X	MG RESISTOR				R2207	NRSA63J-104X	MG RESISTOR		
	R 573	NRSA63J-432X	MG RESISTOR				R2208	NRSA63J-104X	MG RESISTOR		

■ Electrical parts list (DSP board)

Block No. 05

△	Item	Parts number	Parts name	Remarks	Area	△	Item	Parts number	Parts name	Remarks	Area
	R2221	NRSA63J-333X	MG RESISTOR				R2506	NRSA63J-473X	MG RESISTOR		
	R2222	NRSA63J-333X	MG RESISTOR				R2507	NRSA63J-473X	MG RESISTOR		
	R2225	NRSA63J-104X	MG RESISTOR				R2508	NRSA63J-473X	MG RESISTOR		
	R2226	NRSA63J-104X	MG RESISTOR				R2511	NRSA63J-221X	MG RESISTOR		
	R2227	NRSA63J-104X	MG RESISTOR				R2512	NRSA63J-221X	MG RESISTOR		
	R2231	NRSA63J-333X	MG RESISTOR				R2513	NRSA63J-221X	MG RESISTOR		
	R2232	NRSA63J-333X	MG RESISTOR				R2514	NRSA63J-103X	MG RESISTOR		
	R2233	NRSA63J-333X	MG RESISTOR				R2515	NRSA63J-103X	MG RESISTOR		
	R2234	NRSA63J-333X	MG RESISTOR				R2516	NRSA63J-103X	MG RESISTOR		
	R2235	NRSA63J-333X	MG RESISTOR				R2517	NRSA63J-103X	MG RESISTOR		
	R2236	NRSA63J-333X	MG RESISTOR				R2518	NRSA63J-221X	MG RESISTOR		
	R2237	NRSA63J-683X	MG RESISTOR				R2519	NRSA63J-221X	MG RESISTOR		
	R2238	NRSA63J-683X	MG RESISTOR				R2520	NRSA63J-221X	MG RESISTOR		
	R2257	NRSA63J-104X	MG RESISTOR				R2521	NRSA63J-103X	MG RESISTOR		
	R2258	NRSA63J-104X	MG RESISTOR				R2522	NRSA63J-103X	MG RESISTOR		
	R2261	NRSA63J-104X	MG RESISTOR				R2523	NRSA63J-103X	MG RESISTOR		
	R2262	NRSA63J-104X	MG RESISTOR				R2531	NRSA63F-511X	MG RESISTOR		
	R2263	NRSA63J-103X	MG RESISTOR				R2532	NRSA63F-102X	MG RESISTOR		
	R2264	NRSA63J-103X	MG RESISTOR				R2551	NRSA63J-183X	MG RESISTOR		
	R2273	NRSA63J-103X	MG RESISTOR				R2552	NRSA63J-221X	MG RESISTOR		
	R2274	NRSA63J-103X	MG RESISTOR				R2553	NRSA63J-221X	MG RESISTOR		
	R2275	NRSA63J-682X	MG RESISTOR				R2554	NRSA63J-221X	MG RESISTOR		
	R2276	NRSA63J-682X	MG RESISTOR				R2555	NRSA63J-221X	MG RESISTOR		
	R2277	NRSA63J-105X	MG RESISTOR				R2557	NRSA63J-221X	MG RESISTOR		
	R2278	NRSA63J-105X	MG RESISTOR				R2559	NRSA63J-221X	MG RESISTOR		
	R2283	NRSA63J-103X	MG RESISTOR				R2560	NRSA63J-221X	MG RESISTOR		
	R2284	NRSA63J-103X	MG RESISTOR				R2561	NRSA63J-112X	MG RESISTOR		
	R2285	NRSA63J-113X	MG RESISTOR				R2562	NRSA63J-112X	MG RESISTOR		
	R2286	NRSA63J-113X	MG RESISTOR				R2563	NRSA63J-112X	MG RESISTOR		
	R2301	NRSA63J-103X	MG RESISTOR				R2564	NRSA63J-750X	MG RESISTOR		
	R2302	NRSA63J-103X	MG RESISTOR				R2568	NRSA63J-221X	MG RESISTOR		
	R2305	NRSA63J-102X	MG RESISTOR				R2571	NRSA63J-512X	MG RESISTOR		
	R2306	NRSA63J-102X	MG RESISTOR				R2572	NRSA63J-512X	MG RESISTOR		
	R2307	NRSA63J-104X	MG RESISTOR				R2573	NRSA63J-512X	MG RESISTOR		
	R2308	NRSA63J-104X	MG RESISTOR				R2581	NRSA63J-221X	MG RESISTOR		
	R2349	NRSA63J-303X	MG RESISTOR				R2582	NRSA63J-221X	MG RESISTOR		
	R2350	NRSA63J-303X	MG RESISTOR				R2583	NRSA63J-221X	MG RESISTOR		
	R2351	NRSA63J-113X	MG RESISTOR				R2584	NRSA63J-221X	MG RESISTOR		
	R2352	NRSA63J-113X	MG RESISTOR				R2585	NRSA63J-221X	MG RESISTOR		
	R2353	NRSA63J-222X	MG RESISTOR				R2586	NRSA63J-221X	MG RESISTOR		
	R2354	NRSA63J-222X	MG RESISTOR				R2587	NRSA63J-221X	MG RESISTOR		
	R2355	NRSA63J-103X	MG RESISTOR				R2589	NRSA63J-221X	MG RESISTOR		
	R2356	NRSA63J-103X	MG RESISTOR				R2591	NRSA63J-221X	MG RESISTOR		
	R2357	NRSA63J-223X	MG RESISTOR				R2593	NRSA63J-221X	MG RESISTOR		
	R2358	NRSA63J-223X	MG RESISTOR				R2594	NRSA63J-221X	MG RESISTOR		
	R2359	NRSA63J-103X	MG RESISTOR				R2595	NRSA63J-221X	MG RESISTOR		
	R2360	NRSA63J-103X	MG RESISTOR				R2596	NRSA63J-221X	MG RESISTOR		
	R2363	NRSA63J-104X	MG RESISTOR				R2597	NRSA63J-102X	MG RESISTOR		
	R2364	NRSA63J-104X	MG RESISTOR				R2611	NRSA63J-473X	MG RESISTOR		
	R2401	NRSA63J-103X	MG RESISTOR				R2612	NRSA63J-473X	MG RESISTOR		
	R2405	NRSA63J-102X	MG RESISTOR				R2613	NRSA63J-473X	MG RESISTOR		
	R2407	NRSA63J-104X	MG RESISTOR				R2614	NRSA63J-473X	MG RESISTOR		
	R2425	NRSA63J-103X	MG RESISTOR				R2615	NRSA63J-473X	MG RESISTOR		
	R2427	NRSA63J-104X	MG RESISTOR				R2616	NRSA63J-473X	MG RESISTOR		
	R2429	NRSA63J-103X	MG RESISTOR				R2701	NRSA63J-473X	MG RESISTOR		
	R2431	NRSA63J-113X	MG RESISTOR				R2702	NRSA63J-473X	MG RESISTOR		
	R2433	NRSA63J-823X	MG RESISTOR				R2703	NRSA63J-473X	MG RESISTOR		
	R2485	NRSA63J-102X	MG RESISTOR				R2709	NRSA63J-221X	MG RESISTOR		
	R2501	NRSA63J-105X	MG RESISTOR				R2715	NRSA63J-432X	MG RESISTOR		
	R2502	NRSA63J-473X	MG RESISTOR				R2716	NRSA63J-221X	MG RESISTOR		
	R2503	NRSA63J-473X	MG RESISTOR				R2717	NRSA63J-221X	MG RESISTOR		
	R2504	NRSA63J-473X	MG RESISTOR				R2718	NRSA63J-221X	MG RESISTOR		
	R2505	NRSA63J-473X	MG RESISTOR				UN560	GP1FA550TZ	OPT TRANSMITTER		
							UN561	GP1FA550RZ	OPT RECEIVER		
							UN562	GP1FA550RZ	OPT RECEIVER		
							UN563	GP1FA550RZ	OPT RECEIVER		
							X 581	NAX0275-001X	1COSCIALLATOR		
							X2501	NAX0308-001X	CRYSTAL		
							X2551	NAX0213-001X	CRYSTAL		

■ Electrical parts list (Micon board)

Block No. 06

△	Item	Parts number	Parts name	Remarks	Area	△	Item	Parts number	Parts name	Remarks	Area
△	C 1	QCZ9104-472	C CAPACITOR	4700PF			D 56	MTZJ6.2B-T2	ZENER DIODE		
	C 51	QFLC2AJ-472Z	M CAPACITOR	4700PF 5% 100V			D 57	1SS133-T2	SI DIODE		
	C 52	QETM1EM-108	E CAPACITOR	1000MF 20% 25V		△	D 61	10E2-FD	DIODE		
	C 54	QETN1CM-477Z	E CAPACITOR	470MF 20% 16V		△	D 62	1SR35-400A-T5	DIODE		
	C 55	QCF31HZ-472Z	C CAPACITOR	4700PF +80:-20%		△	D 63	10E2-FD	DIODE		
	C 61	QFLC2AJ-104Z	M CAPACITOR	.10MF 5% 100V		△	D 64	1SR35-400A-T5	DIODE		
	C 62	QFLC2AJ-104Z	M CAPACITOR	.10MF 5% 100V			D 67	1SS133-T2	SI DIODE		
	C 63	QFLC2AJ-104Z	M CAPACITOR	.10MF 5% 100V			D 71	1SR35-400A-T5	DIODE		
	C 65	QETM1VM-338	E CAPACITOR	3300MF 20% 35V			D 72	1SR35-400A-T5	DIODE		
	C 66	QETM1VM-108	E CAPACITOR	1000MF 20% 35V			D 73	1SR35-400A-T5	DIODE		
	C 68	QFLC1HJ-473Z	M CAPACITOR	.047MF 5% 50V			D 74	MTZJ33C-T2	Z DIODE		
	C 69	QFLC1HJ-473Z	M CAPACITOR	.047MF 5% 50V			D 75	MTZJ8.2C-T2	ZENER DIODE		
	C 70	QETN1HM-227Z	E CAPACITOR	220MF 20% 50V			D 900	1SR35-400A-T5	DIODE		
	C 71	QETN1JM-107Z	E CAPACITOR	100MF 20% 63V			D 901	1SR35-400A-T5	DIODE		
	C 72	QETN1HM-226Z	E CAPACITOR	22MF 20% 50V			D 902	1SR35-400A-T5	DIODE		
	C 73	QETN1HM-226Z	E CAPACITOR	22MF 20% 50V			D 904	1SS133-T2	SI DIODE		
	C 74	QETN1HM-105Z	E CAPACITOR	1.0MF 20% 50V			D 921	MTZJ5.6C-T2	ZENER DIODE		
	C 901	QETN0JM-107Z	E CAPACITOR	100MF 20% 6.3V			D 931	MTZJ6.2C-T2	Z DIODE		
	C 902	QCZ0205-155Z	ML C CAPACITOR	1.5MF			D 941	MTZJ5.6C-T2	ZENER DIODE		
	C 903	QETN0JM-228Z	E CAPACITOR	2200MF 20% 6.3V			D 951	MTZJ13C-T2	ZENER DIODE		
	C 904	QETN1HM-225Z	E CAPACITOR	2.2MF 20% 50V			D 961	MTZJ13C-T2	ZENER DIODE		
	C 905	QDVB1EZ-223Y	C CAPACITOR				D 971	MTZJ10C-T2	Z DIODE		
	C 921	QETN1EM-107Z	E CAPACITOR	100MF 20% 25V			D 975	1SS133-T2	SI DIODE		
	C 922	QCF31HZ-472Z	C CAPACITOR	4700PF +80:-20%			D 976	1SS133-T2	SI DIODE		
	C 931	QETN1EM-107Z	E CAPACITOR	100MF 20% 25V			D 977	1SS133-T2	SI DIODE		
	C 932	QCF31HZ-472Z	C CAPACITOR	4700PF +80:-20%			D 978	1SS133-T2	SI DIODE		
	C 941	QETN1EM-107Z	E CAPACITOR	100MF 20% 25V			D 979	1SS133-T2	SI DIODE		
	C 942	QCF31HZ-472Z	C CAPACITOR	4700PF +80:-20%			D 993	1SS133-T2	SI DIODE		
	C 951	QETN1EM-107Z	E CAPACITOR	100MF 20% 25V			EP 1	E409182-001SM	GRAND TERMINAL		
	C 952	QCF31HZ-472Z	C CAPACITOR	4700PF +80:-20%			EP 51	QNZ0136-001Z	EARTH PLATE		
	C 961	QETN1EM-107Z	E CAPACITOR	100MF 20% 25V			EP 91	E406523-001SM	GND BKT		
	C 962	QCF31HZ-472Z	C CAPACITOR	4700PF +80:-20%			EP901	QNZ0136-001Z	EARTH PLATE		
	C 971	QETN1EM-107Z	E CAPACITOR	100MF 20% 25V			FC 1	QNG0020-001Z	FUSE CLIP	F001	
	C 972	QCF31HZ-472Z	C CAPACITOR	4700PF +80:-20%			FC 2	QNG0020-001Z	FUSE CLIP	F001	
	C 975	QETN0JM-477Z	E CAPACITOR	470MF 20% 6.3V			FC 61	QNG0020-001Z	FUSE CLIP	F061	
	C 981	QCBB1HK-331Y	C CAPACITOR	330PF 10% 50V			FC 62	QNG0020-001Z	FUSE CLIP	F061	
	C 982	QCBB1HK-331Y	C CAPACITOR	330PF 10% 50V			FC 63	QNG0020-001Z	FUSE CLIP	F062	
	C 983	QCBB1HK-331Y	C CAPACITOR	330PF 10% 50V			FC 64	QNG0020-001Z	FUSE CLIP	F062	
	C 984	QCBB1HK-331Y	C CAPACITOR	330PF 10% 50V			FL991	QQR0590-001	FILTER		
	C 985	QCBB1HK-103Y	C CAPACITOR	.010MF 10% 50V			FL992	QQR0590-001	FILTER		
	C 991	QFLC1HJ-562Z	M CAPACITOR	5600PF 5% 50V			FW 51	QUM137-10DGZ4	PARA RIBON WIRE		
	C 992	QFLC1HJ-562Z	M CAPACITOR	5600PF 5% 50V			FW831	QUM134-08DGZ4	PARA RIBON WIRE		
	C 993	QCBB1HK-101Y	C CAPACITOR	100PF 10% 50V			FW881	QUM133-44DGZ4	PARA RIBON WIRE		
	C 994	QCBB1HK-271Y	C CAPACITOR	270PF 10% 50V			HL901	VYH7237-002	IC HOLDER		
	CN 55	QGD2501C1-03Z	SOCKET				HS921	E70945-H40B	HEAT SINK		
	CN 56	QGD2501C1-04Z	SOCKET				HS931	E70945-H40B	HEAT SINK		
	CN 71	QGB2510J1-11	CONNECTOR				HS941	E70945-H40B	HEAT SINK		
	CN 81	QGB2510J1-09	CONNECTOR				HS951	E70306-001	HEAT SINK		
	CN101	QGB2501J1-12	CONNECTOR				HS961	E70306-001	HEAT SINK		
	CN201	QGB2510J1-11	CONNECTOR				HS971	E70306-001	HEAT SINK		
	CN241	QGB2510J1-12	CONNECTOR				△	IC901	MN101C49GHM	IC	
	CN301	QGB2510J1-14	CONNECTOR				IC903	IC-PST9139-T	IC		
	CN303	QGB2510J1-13	CONNECTOR				J 91	QNS0022-001	JACK		
	CN400	QGF1205C1-10	CONNECTOR				Q 52	KTD863/Y/-T	TRANSISTOR		
	CN402	QGF1205C1-08	CONNECTOR				Q 53	KRC105M-T	D TRANSISTOR		
	CN601	QGB2510J1-07	CONNECTOR				Q 61	KRC105M-T	D TRANSISTOR		
	CN811	QGA3901F2-03	CONNECTOR				Q 71	KTA1046/Y/	TRANSISTOR		
	CN931	QGD2501C1-04Z	SOCKET				Q 74	KTC3200/GL/-T	TRANSISTOR		
	CN932	QGD2501C1-03Z	SOCKET				Q 901	KRC107M-T	D TRANSISTOR		
△	D 51	1SR35-400A-T5	DIODE				Q 903	KRC105M-T	D TRANSISTOR		
△	D 52	1SR35-400A-T5	DIODE				Q 904	KRC105M-T	D TRANSISTOR		
△	D 53	1SR35-400A-T5	DIODE				Q 905	KRC105M-T	D TRANSISTOR		
△	D 54	1SR35-400A-T5	DIODE				Q 906	KRC105M-T	D TRANSISTOR		

■ Electrical parts list (Micon board)

Block No. 06

△	Item	Parts number	Parts name	Remarks	Area
	Q 907	KRC105M-T	D TRANSISTOR		
	Q 908	KRC105M-T	D TRANSISTOR		
△	Q 921	2SD2395/EF/	TRANSISTOR		
△	Q 931	2SD2395/EF/	TRANSISTOR		
△	Q 941	2SD2395/EF/	TRANSISTOR		
	Q 951	2SD2395/EF/	TRANSISTOR		
	Q 961	KTA1046/Y/	TRANSISTOR		
	Q 971	2SD2395/EF/	TRANSISTOR		
△	R 1	QRZ9044-335	COMP RESISTOR	3.3M 1/0W	
△	R 53	QRJ146J-6R8X	UNF C RESISTOR	6.8 5% 1/4W	
	R 54	QRE141J-821Y	C RESISTOR	820 5% 1/4W	
	R 61	QRJ146J-3R3X	UNF C RESISTOR	3.3 5% 1/4W	
△	R 67	QRJ146J-120X	UNF C RESISTOR	12 5% 1/4W	
	R 72	QRJ146J-332X	UNF C RESISTOR	3.3K 5% 1/4W	
	R 73	QRE141J-223Y	C RESISTOR	22K 5% 1/4W	
	R 74	QRE141J-104Y	C RESISTOR	100K 5% 1/4W	
	R 91	QRL022J-471	UNF OMF RESISTOR	470 5% 1/2W	
	R 92	QRL022J-471	UNF OMF RESISTOR	470 5% 1/2W	
	R 903	QRE141J-331Y	C RESISTOR	330 5% 1/4W	
	R 908	QRE141J-223Y	C RESISTOR	22K 5% 1/4W	
	R 910	QRE141J-223Y	C RESISTOR	22K 5% 1/4W	
	R 911	QRE141J-472Y	C RESISTOR	4.7K 5% 1/4W	
	R 915	QRT022J-8R2	UNF MF RESISTOR	8.2 5% 1/2W	
	R 916	QRT022J-8R2	UNF MF RESISTOR	8.2 5% 1/2W	
	R 921	QRK126J-330X	UNF C RESISTOR	33 5% 1/2W	
	R 922	QRK126J-330X	UNF C RESISTOR	33 5% 1/2W	
	R 923	QRJ146J-272X	UNF C RESISTOR	2.7K 5% 1/4W	
	R 924	QRE141J-103Y	C RESISTOR	10K 5% 1/4W	
	R 925	QRE141J-221Y	C RESISTOR	220 5% 1/4W	
	R 926	QRE141J-221Y	C RESISTOR	220 5% 1/4W	
	R 927	QRE141J-221Y	C RESISTOR	220 5% 1/4W	
	R 928	QRE141J-221Y	C RESISTOR	220 5% 1/4W	
	R 929	QRE141J-221Y	C RESISTOR	220 5% 1/4W	
	R 930	QRE141J-103Y	C RESISTOR	10K 5% 1/4W	
	R 931	QRL017J-430	UNF OMF RESISTOR	43 5% 1/1W	
	R 932	QRL017J-430	UNF OMF RESISTOR	43 5% 1/1W	
	R 933	QRJ146J-272X	UNF C RESISTOR	2.7K 5% 1/4W	
	R 937	QRE141J-221Y	C RESISTOR	220 5% 1/4W	
	R 938	QRE141J-221Y	C RESISTOR	220 5% 1/4W	
	R 939	QRE141J-221Y	C RESISTOR	220 5% 1/4W	
	R 940	QRJ146J-4R7X	UNF C RESISTOR	4.7 5% 1/4W	
	R 941	QRK126J-330X	UNF C RESISTOR	33 5% 1/2W	
	R 942	QRK126J-330X	UNF C RESISTOR	33 5% 1/2W	
	R 943	QRJ146J-272X	UNF C RESISTOR	2.7K 5% 1/4W	
	R 944	QRE141J-221Y	C RESISTOR	220 5% 1/4W	
	R 945	QRE141J-221Y	C RESISTOR	220 5% 1/4W	
	R 946	QRE141J-221Y	C RESISTOR	220 5% 1/4W	
	R 947	QRE141J-221Y	C RESISTOR	220 5% 1/4W	
	R 948	QRE141J-221Y	C RESISTOR	220 5% 1/4W	
	R 949	QRE141J-221Y	C RESISTOR	220 5% 1/4W	
	R 951	QRK126J-120X	UNF C RESISTOR	12 5% 1/2W	
	R 953	QRJ146J-222X	UNF C RESISTOR	2.2K 5% 1/4W	
	R 954	QRE141J-221Y	C RESISTOR	220 5% 1/4W	
	R 955	QRE141J-221Y	C RESISTOR	220 5% 1/4W	
	R 956	QRE141J-221Y	C RESISTOR	220 5% 1/4W	
	R 961	QRK126J-120X	UNF C RESISTOR	12 5% 1/2W	
	R 963	QRJ146J-222X	UNF C RESISTOR	2.2K 5% 1/4W	
	R 965	QRE141J-103Y	C RESISTOR	10K 5% 1/4W	
	R 966	QRE141J-103Y	C RESISTOR	10K 5% 1/4W	
	R 967	QRE141J-103Y	C RESISTOR	10K 5% 1/4W	
	R 968	QRE141J-103Y	C RESISTOR	10K 5% 1/4W	
	R 969	QRE141J-103Y	C RESISTOR	10K 5% 1/4W	
	R 971	QRJ146J-120X	UNF C RESISTOR	12 5% 1/4W	

△	Item	Parts number	Parts name	Remarks	Area
	R 973	QRJ146J-332X	UNF C RESISTOR	3.3K 5% 1/4W	
	R 975	QRJ146J-220X	UNF C RESISTOR	22 5% 1/4W	
	R 976	QRE141J-472Y	C RESISTOR	4.7K 5% 1/4W	
	R 977	QRE141J-472Y	C RESISTOR	4.7K 5% 1/4W	
	R 978	QRE141J-472Y	C RESISTOR	4.7K 5% 1/4W	
	R 979	QRE141J-472Y	C RESISTOR	4.7K 5% 1/4W	
	R 980	QRE141J-221Y	C RESISTOR	220 5% 1/4W	
	R 981	QRE141J-221Y	C RESISTOR	220 5% 1/4W	
	R 982	QRE141J-221Y	C RESISTOR	220 5% 1/4W	
	R 983	QRE141J-221Y	C RESISTOR	220 5% 1/4W	
	R 984	QRE141J-221Y	C RESISTOR	220 5% 1/4W	
	R 985	QRE141J-221Y	C RESISTOR	220 5% 1/4W	
	R 986	QRE141J-221Y	C RESISTOR	220 5% 1/4W	
	R 987	QRE141J-221Y	C RESISTOR	220 5% 1/4W	
	R 991	QRE141J-472Y	C RESISTOR	4.7K 5% 1/4W	
	R 992	QRE141J-472Y	C RESISTOR	4.7K 5% 1/4W	
	R 993	QRE141J-622Y	C RESISTOR	6.2K 5% 1/4W	
	R 994	QRE141J-512Y	C RESISTOR	5.1K 5% 1/4W	
	R 995	QRE141J-133Y	C RESISTOR	13K 5% 1/4W	
	R 996	QRE141J-332Y	C RESISTOR	3.3K 5% 1/4W	
	R 997	QRE141J-153Y	C RESISTOR	15K 5% 1/4W	
	R 998	QRE141J-562Y	C RESISTOR	5.6K 5% 1/4W	
	R 999	QRE141J-103Y	C RESISTOR	10K 5% 1/4W	
△	RY 1	QSK0098-001	RELAY		
	RY 62	QSK0088-001	RELAY		
	RY 63	QSK0088-001	RELAY		
△	T 2	QQT0317-001	POWER TRANSF		
	TA 1	QNZ0079-001Z	TAB		
	TA 2	QNZ0079-001Z	TAB		
△	TH 71	QAD0095-4R7Z	POSISTOR		
	X 901	QAX0246-001Z	RESONATOR		

■ Electrical parts list (Tuner board)

Block No. 07

△	Item	Parts number	Parts name	Remarks	Area
	AT101	QNB0014-001	ANT TERMINAL		
	BK 1	LV31618-001A	SHIELD BKT		
	C 101	NCB21HK-103X	C CAPACITOR		
	C 103	NCB21HK-223X	C CAPACITOR		
	C 105	NCB21HK-223X	C CAPACITOR		
	C 107	QEK1CM-226Z	E CAPACITOR	22MF 20% 16V	
	C 111	NCB21HK-473X	C CAPACITOR		
	C 112	NDC21HJ-120X	C CAPACITOR		
	C 121	NDC21HJ-120X	C CAPACITOR		
	C 122	NDC21HJ-120X	C CAPACITOR		
	C 123	NCB21HK-473X	C CAPACITOR		
	C 126	NCS21HJ-101X	C CAPACITOR		
	C 128	QENC1HM-474Z	NP E CAPACITOR	.47MF 20% 50V	
	C 129	NCB21HK-102X	C CAPACITOR		
	C 130	QEK1AM-107Z	E CAPACITOR	100MF 20% 10V	
	C 133	QEK1CM-226Z	E CAPACITOR	22MF 20% 16V	
	C 134	NCB21HK-222X	C CAPACITOR		
	C 135	NCB21HK-223X	C CAPACITOR		
	C 136	QEK1HM-105Z	E CAPACITOR	1.0MF 20% 50V	
	C 137	NCB21HK-331X	C CAPACITOR		
	C 138	NCB21HK-473X	C CAPACITOR		
	C 139	NCB21HK-333X	C CAPACITOR		
	C 140	NCB21HK-333X	C CAPACITOR		
	C 141	NCB21HK-473X	C CAPACITOR		
	C 143	NCB21HK-223X	C CAPACITOR		
	C 144	NCB21HK-473X	C CAPACITOR		
	C 146	QEK1HM-105Z	E CAPACITOR	1.0MF 20% 50V	
	C 147	QEK1HM-105Z	E CAPACITOR	1.0MF 20% 50V	
	C 148	QEK1HM-224Z	E CAPACITOR	.22MF 20% 50V	
	C 149	QEK1HM-105Z	E CAPACITOR	1.0MF 20% 50V	
	C 150	QEK1CM-226Z	E CAPACITOR	22MF 20% 16V	
	C 156	QDGB1HK-102Y	C CAPACITOR		
	C 157	NCB21HK-473X	C CAPACITOR		
	C 158	QEK1CM-226Z	E CAPACITOR	22MF 20% 16V	
	C 161	QEK41CM-106	E CAPACITOR	10MF 20% 16V	
	C 162	QEK41CM-106	E CAPACITOR	10MF 20% 16V	
	C 163	NCB21HK-223X	C CAPACITOR		
	C 164	NCB21HK-473X	C CAPACITOR		
	C 168	QEK1HM-105Z	E CAPACITOR	1.0MF 20% 50V	
	C 184	QEK1CM-107Z	E CAPACITOR	100MF 20% 16V	
	C 185	QEK41CM-106	E CAPACITOR	10MF 20% 16V	
	C 186	QEK41CM-106	E CAPACITOR	10MF 20% 16V	
	CF101	QAX0419-001Z	C FILTER		
	CF102	QAX0604-001Z	C FILTER		
	CF103	QAX0519-001Z	C FILTER		
	CN111	QGB2501K2-12	CONECTOR		
	D 121	1SS133-T2	SI DIODE		
	D 123	1SS133-T2	SI DIODE		
	D 124	1SS133-T2	SI DIODE		
	D 125	1SS133-T2	SI DIODE		
	D 129	1SS133-T2	SI DIODE		
	IC102	LA1838	IC		
	IC121	LC72136N	IC		
	Q 102	2SC535/BC-T	TRANSISTOR		
	Q 103	2SC461/BC-T	TRANSISTOR		
	Q 121	KRA103M-T	TRANSISTOR	FM+B	
	R 103	NRSA02J-221X	MG RESISTOR		
	R 104	NRSA02J-272X	MG RESISTOR		
	R 105	NRSA02J-391X	MG RESISTOR		
	R 106	NRSA02J-102X	MG RESISTOR		
	R 107	NRSA02J-391X	MG RESISTOR		
	R 108	NRSA02J-332X	MG RESISTOR		
	R 109	NRSA02J-221X	MG RESISTOR		

△	Item	Parts number	Parts name	Remarks	Area
	R 115	NRSA02J-104X	MG RESISTOR		
	R 119	NRSA02J-103X	MG RESISTOR		
	R 122	NRSA02J-472X	MG RESISTOR		
	R 124	NRSA02J-222X	MG RESISTOR		
	R 126	NRSA02J-562X	MG RESISTOR		
	R 127	NRSA02J-822X	MG RESISTOR		
	R 128	NRSA02J-472X	MG RESISTOR		
	R 129	NRSA02J-222X	MG RESISTOR		
△	R 130	QRZ9005-680X	F RESISTOR	68 1/0W	
	R 132	NRSA02J-393X	MG RESISTOR		
	R 133	NRSA02J-392X	MG RESISTOR		
	R 134	NRSA02J-102X	MG RESISTOR		
	R 140	NRSA02J-183X	MG RESISTOR		
	R 141	NRSA02J-102X	MG RESISTOR		
	R 142	NRSA02J-470X	MG RESISTOR		
	R 143	NRSA02J-562X	MG RESISTOR		
	R 144	NRSA02J-332X	MG RESISTOR		
	R 145	NRSA02J-103X	MG RESISTOR		
	R 146	NRSA02J-392X	MG RESISTOR		
	R 147	NRSA02J-332X	MG RESISTOR		
	R 150	NRSA02J-331X	MG RESISTOR		
	R 157	NRSA02J-682X	MG RESISTOR		
	R 158	NRSA02J-682X	MG RESISTOR		
	R 161	NRSA02J-102X	MG RESISTOR		
	R 162	NRSA02J-102X	MG RESISTOR		
	R 182	NRSA02J-103X	MG RESISTOR		
	R 183	NRSA02J-103X	MG RESISTOR		
	R 184	NRSA02J-103X	MG RESISTOR		
	RF101	QAU0124-002	FRONT END		
	T 111	QQR0796-001	COIL BLOCK		
	T 142	QQR0973-001	IFT		
	X 121	QAX0402-001	CRYSTAL		

Packing materials and accessories parts list

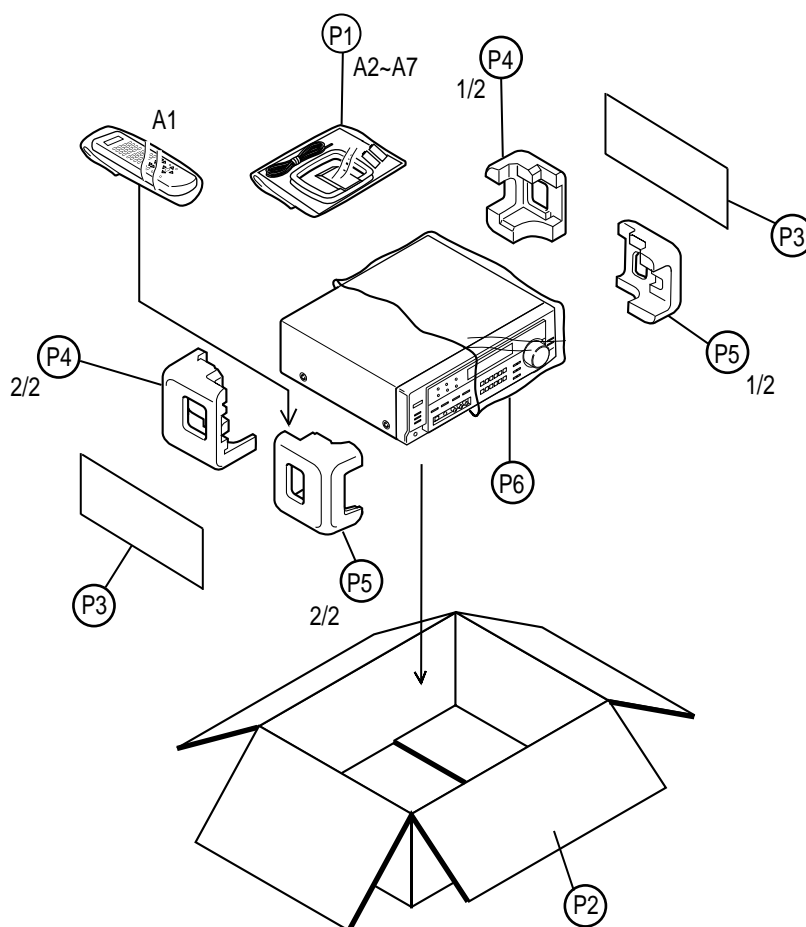
Block No. M 2 M MBlock No. M 3 M M

Parts list (Packing)

Block No. M2MM

Item	Parts number	Parts name	Q'ty	Description	Area
P 1	QPA02503505P	POLY BAG	1	FOR INST	
P 2	LV20989-010A	CARTON BOX	1		
P 3	LV32034-003A	SHEET	2		
P 4	LV20947-001A	PACKING PAD	1		
P 5	LV20948-001A	PACKING PAD	1		
P 6	QPC06507015P	POLY BAG	1	FOR SET	

Parts list (Accessories)

Block No. M3MM

Item	Parts number	Parts name	Q'ty	Description	Area
A 1	RM-SRX8010J	REMOCON	1		
A 2	-----	BATTERY	1		
A 3	LVT0618-001B	INST BOOK	1	ENG	
A 4	EWP503-001C	ANT.WIRE	1		
A 5	QAL0204-001	AM LOOP ANT	1		
A 6	BT-51020-2	J=REGIST CARD	1		
A 7	YU20333	SAFETY INST.	1		