

BeoVision 6 – 26

Type 925x

Service Center repair guide

English, German, French, Italian, Spanish, Danish, Dutch

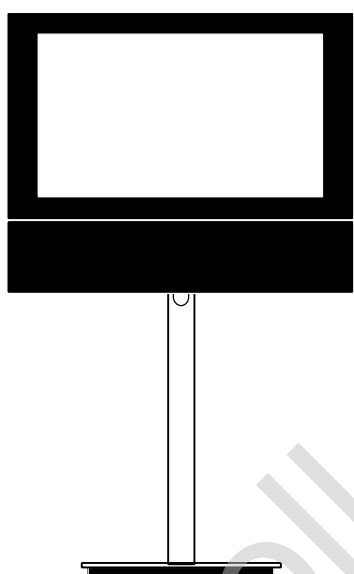

This Service Center repair guide must be returned with the defective parts/back-up suitcase !

CONTENTS

English	1
German	2
French	3
Italian	4
Spanish	5
Danish	6
Nederlands	7
Replace modules	8
Specification guidelines for service use	9
Wiring diagram	10
Available parts	11

There is no Brief operation guide in this Service Center repair guide. Instead an english version of the user guide is enclosed the back-up suitcase.

Survey of modules

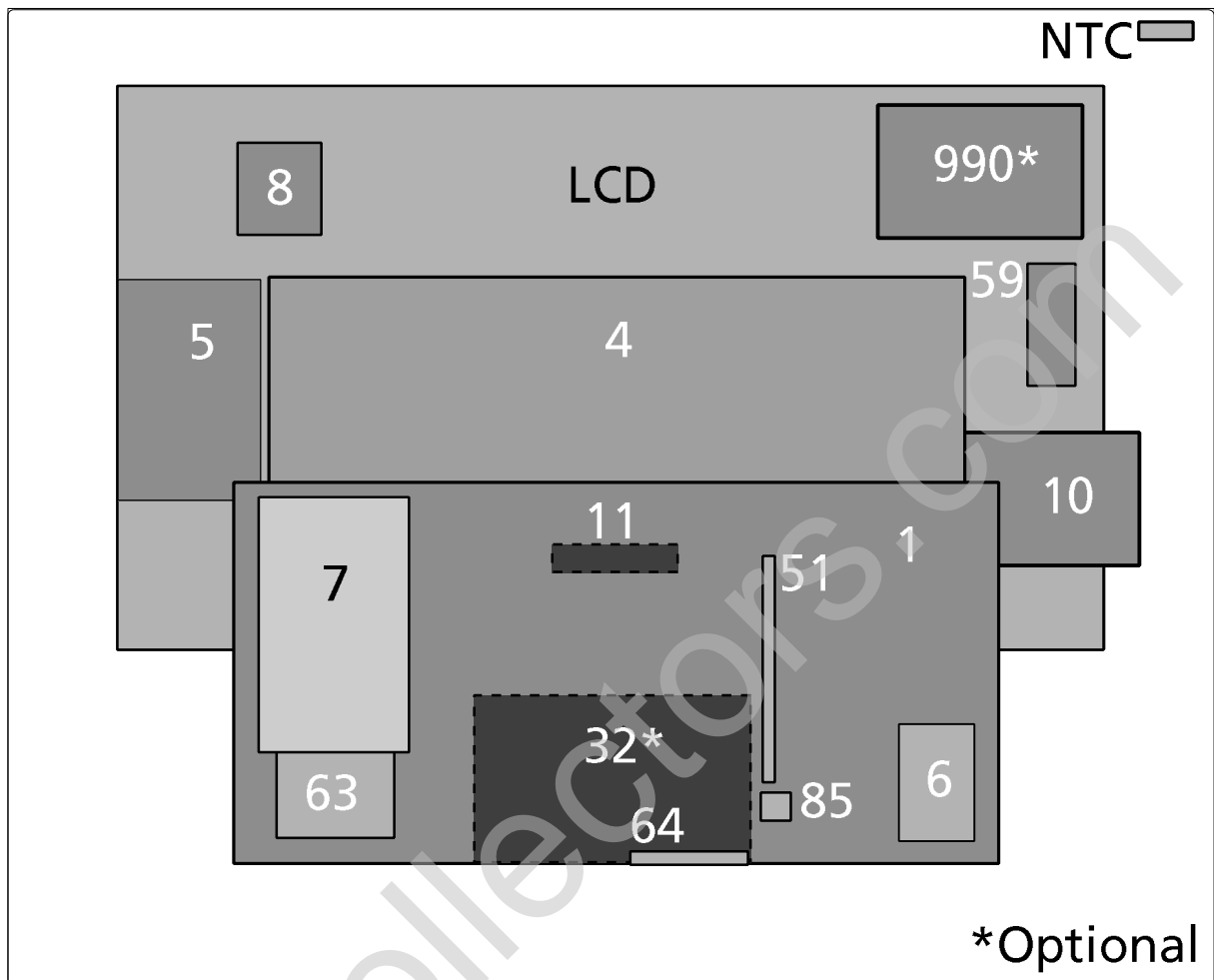

- PCB1, PCB4, PCB5, PCB6, PCB7,Main chassis, module 999
- PCB51, PCB63, PCB64, PCB85
- PCB10.....Sound Out
- PCB11.....IR Receiver
- PCB21, PCB22*DVB-S chassis, module 990
- PCB32*DSM
- PCB59.....Camcorder
- LCD, PCB8.....LCD

How to service 1.2

Fault flow chart 1.7

Placement of measuring points 1.15









Replacement of modules 1.16

Adjustments 1.19

Final check after repair 1.21

Service mode 1.23

Survey of symbols

-  → Push with finger, in arrow direction
-  Disconnect internal plug
-  Connect internal plug
-  Disconnect mains plug
-  Connect mains plug
-  Disconnect aerial or other external plug
-  Connect aerial or other external plug
-  Loosen/remove or fasten/install screw
- ← - - Dashed arrow. Push/pull e.g. PCB, chassis etc. in arrow's direction
- ➔ Filled arrow. Refer to the description for more information.

How to service

Strategy

The television is to be serviced in the customer's home.

The static-protective field service kit must always be used when the product is disassembled or modules are being handled.

The repair involves replacement of the chassis, module(s) or LCD panel, which are supplied in the Back-up suite case.

The replaced modules must be returned for repair at Bang & Olufsen, Module Repair Department.

Fault description and error codes must be returned with the replaced parts. Use the Module Repair form or the form in the Retail Order System, Exchange Module.

The EEPROM must be transferred to the chassis in the television, hereby maintaining the customer settings.

Preparations before service

Fault description and error codes must be returned with the replaced parts. Use the Module Repair form or the form in the Retail Order System, Exchange Module.

Fault explanation and demonstration

Before troubleshooting is initiated, let the customer demonstrate the fault, if possible.

Error code

The error code contains data that may be used for repairing the module(s) and must be returned with the module(s).

Handling the error code

1. Take a note of the error code, for example on the Module repair form.
2. Use the error code when trouble shooting.
3. Return the error code, either on the Module Repair form or in the Retail system.
4. Before returning the television to the customer, clear the error code.

Recommended tools for service

B&O ServiceTool.

Service stand. (Part no. 3375038)

B&O Test tape, for geometry check. (Part no. 6780000)

Ruler for geometry check/adjustment.

White gloves

Soft lint-free cloth.

ML-tester (Part no. 8053404)

B&O programmer (ML kit must be installed) (Part no. 8053368)

Handling and cleaning

Static electricity



Static electricity may damage the television.

Static-protective field service kit.

A static-protective field service kit must always be used when the product is disassembled or modules are being handled.

Follow the instructions in the guide and use the ESD-mat for both old and new modules.

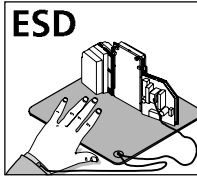

Please note:

When mains voltage on the product is required, remove the connection between the product and the ESD-mat.

The chassis or modules must always be connected to the static-protective field service kit or placed in an ESD-proof bag.

Symbol of safety components



When replacing components with this symbol, the same type has to be used, also the same values for ohm and watt.

The new component is to be mounted in the same way as the replaced one.

Lithium battery



WARNING

Short-circuit and overcharging of some types of lithium batteries may result in a violent explosion.

Transport and handling.

The product must not be placed on the contrast screen.

It is recommended to use the product cover when transporting the television.

The product cover can be ordered, part no. 3375015.

Mounting or dismounting the Service stand.

Place the television on the rear cover and mount the Service stand.

See illustrations page 9.1.

Cleaning

Please refer to the chapter "Final check after repair" or the User's guides.

PIN-code

The TV has a 4 digit PIN-code, of the user's own choice, which must be entered if the TV has been disconnected from the mains for 15-30 min.

If the PIN-code is activated, and the TV has been without mains for 15-30 min., the user will be asked to enter the 4 digit PIN-code when the TV is switched on.

Before the TV is handed in to service it is a good idea to ask the customer to deactivate the PIN-code.

The PIN-code is activated when the TV is shipped from Bang & Olufsen.

Refer to the user guide for further information

PIN-code active prior to service

If the PIN-code is not deactivated prior to service you must use the Service code to unlock the product.

Service code

The service code

- unlocks the product, but does not affect the pin-code setting
- gives you 12 hours service time

Entering the Service code

1. When the product asks for PIN-CODE press and hold **◀** for 3 seconds.
2. The Master code menu appears.
3. Enter the Service code: 1 1 1 1 1.

Important notice concerning Service time

The service time is active as long as the product is connected to the mains, including Standby.

To obtain maximum service time:

Only connect the product to the mains while you are performing actual service on the product.

When the service time is expired, the product can only be unlocked by entering the PIN-code or the Master code.

Registration of the modules

The modules will be registered to the product in the following situations:

- the product has been connected to the mains for more than 12 hours, including Standby time.
- the PIN-code is activated or deactivated.

PIN-code deactivated by customer prior to service

With the PIN-code deactivated prior to service you must be aware of the modules will be registered to the product in the following situations :

- the product has been connected to the mains for more than 12 hours, including Standby time.
- the PIN-code is activated or deactivated.

The registration of modules in the product can only be changed at Bang & Olufsen.

Activate the PIN-code

Select the TV SETUP menu.

Press **◀** twice and then **STOP** to bring up the PINCODE SETUP menu.

Enter the 4 digit Pin-code. Re-enter the code to confirm it and press **GO**.

If you want to change or delete the PIN-code, enter the correct PIN-code and press **GO**.

It is now possible to change the PIN-code or delete the PIN-code.

Enter the PIN-code

If the PIN-code is activated and the TV is disconnected from the mains for more than 15-30 minutes, a PINCODE menu appears as soon as the TV is switched on.

Enter the PIN-code, and the TV starts again.

If the PIN-code has been forgotten

If the PIN-code has been forgotten the only way to unlock the TV again is by entering a 5 digit Master-code.

The Master-code is ordered by sending a request either via the Retail System or on the Master-code formula. If non of these options are available please contact Bang & Olufsen.

When the TV prompts for a PIN-code, press and hold **◀** down to bring up the MASTERCODE menu.

Enter the Master-code and press **GO**. This will deactivate the PIN-code and reactivate the TV.

TV locked by PIN-code

The TV is locked by PIN-code when:

- The PIN-code is activated and the mains is disconnected for more than 15- 30 minutes.

The TV is unlocked when the PIN-code is entered.

The PIN-code counter is set to 5 attempts within 3 hours.

When a wrong PIN-code has been entered 5 times within 3 hours, the television cannot receive any commands for a period of 3 hours.

After this period the PIN-code counter is reset.

The TV must be in standby mode to activate the timer.

Fault flow chart

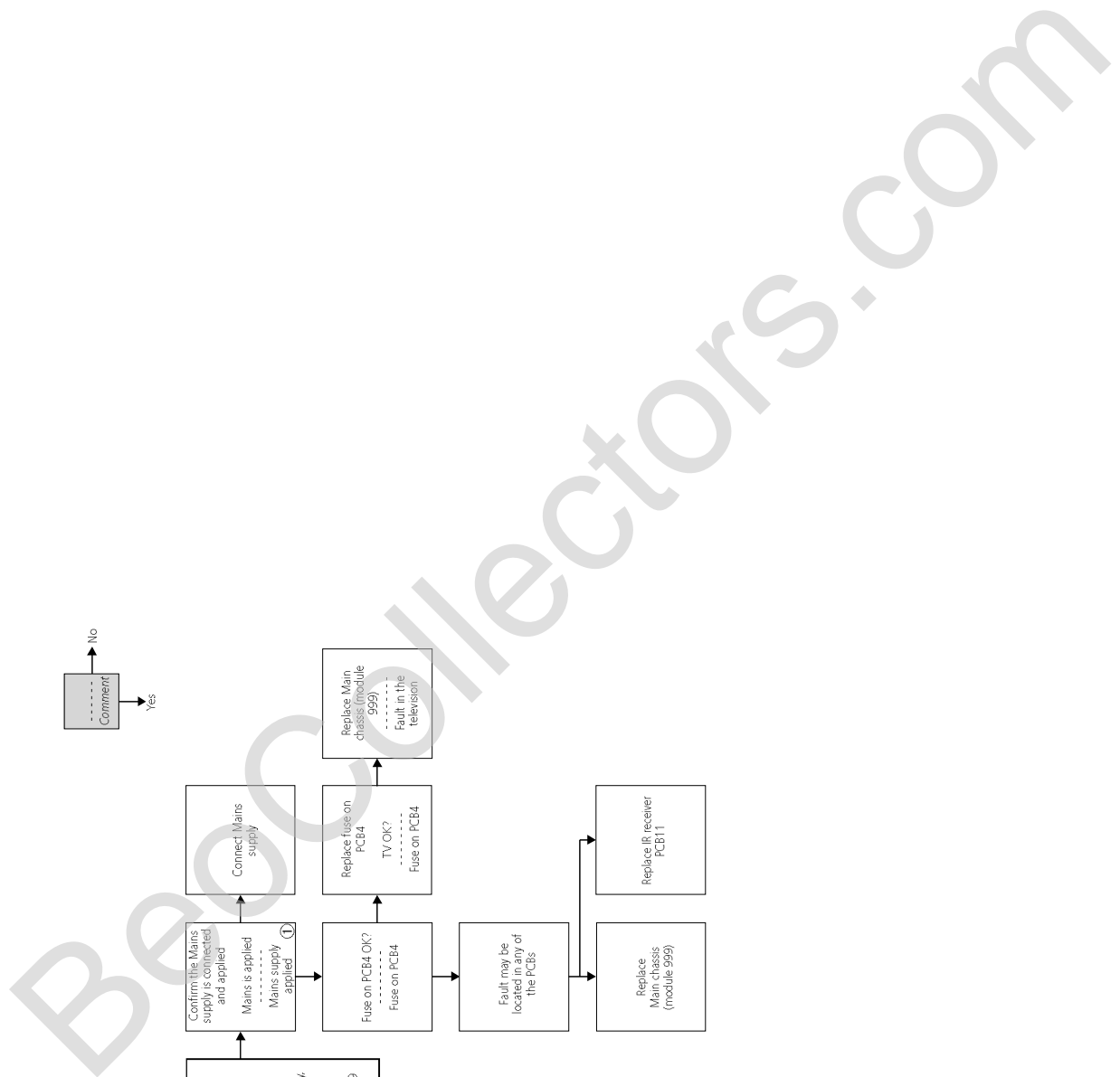
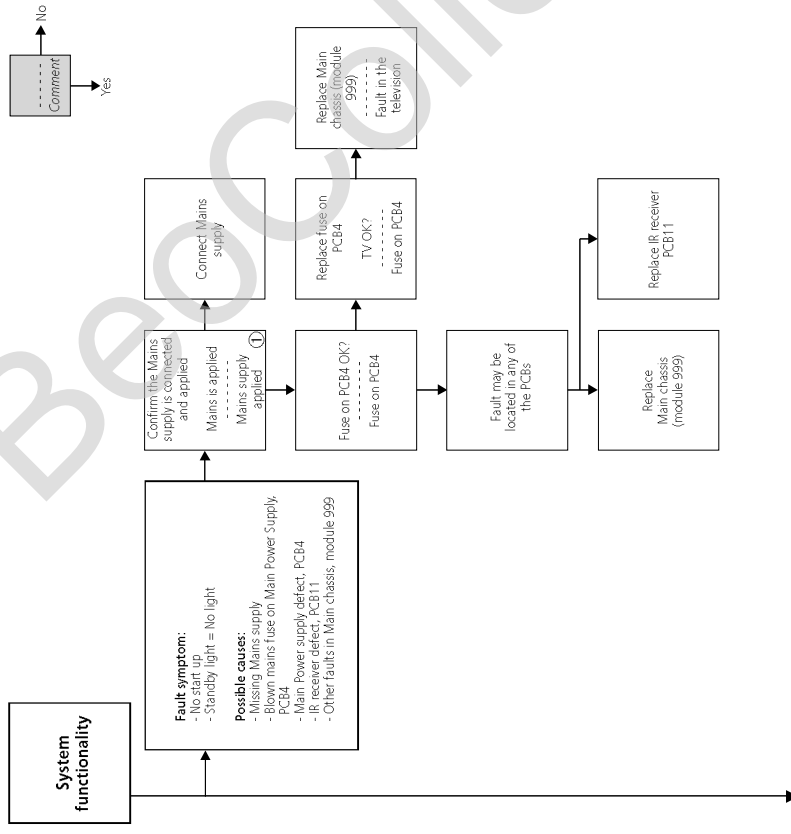

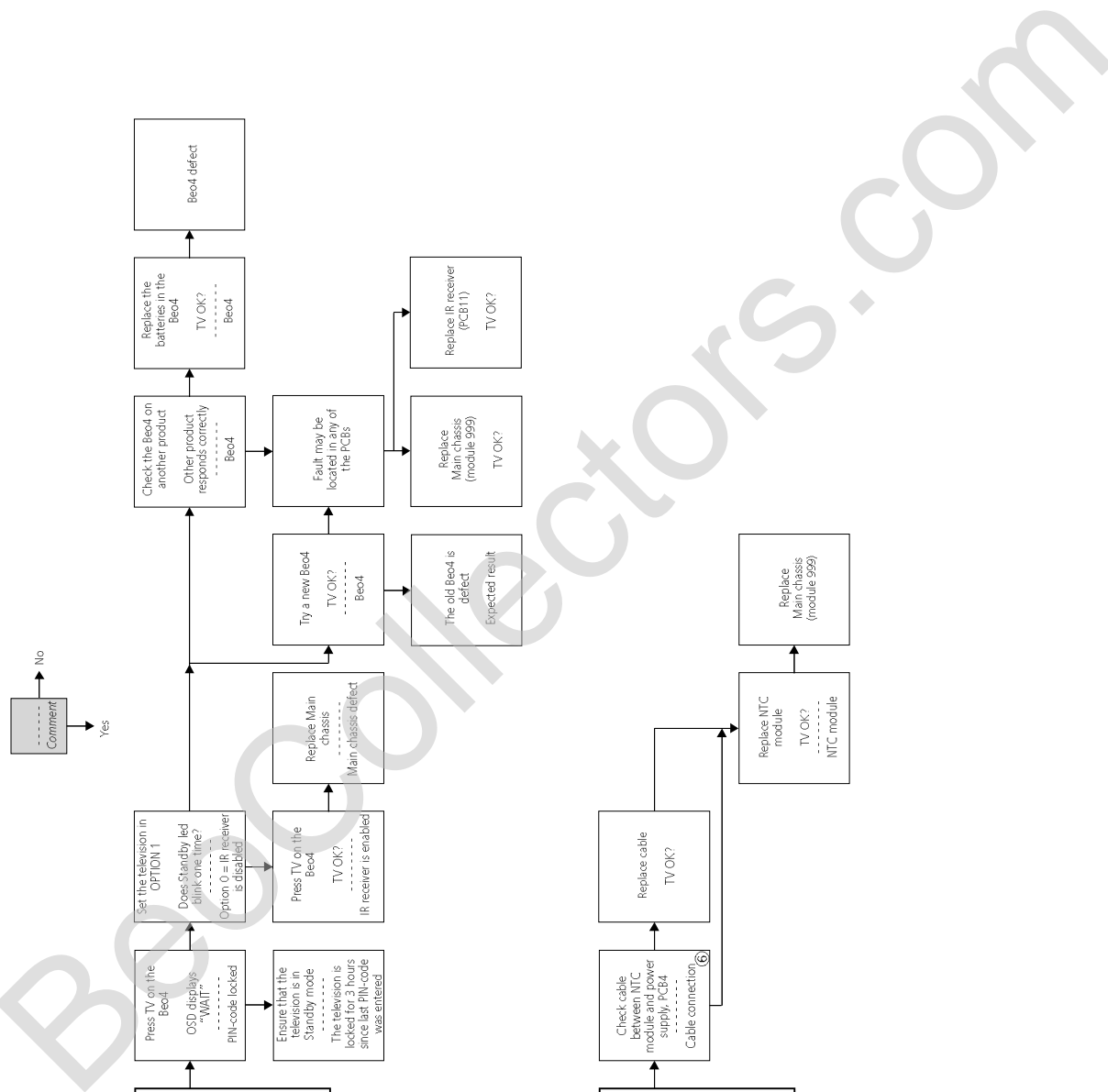
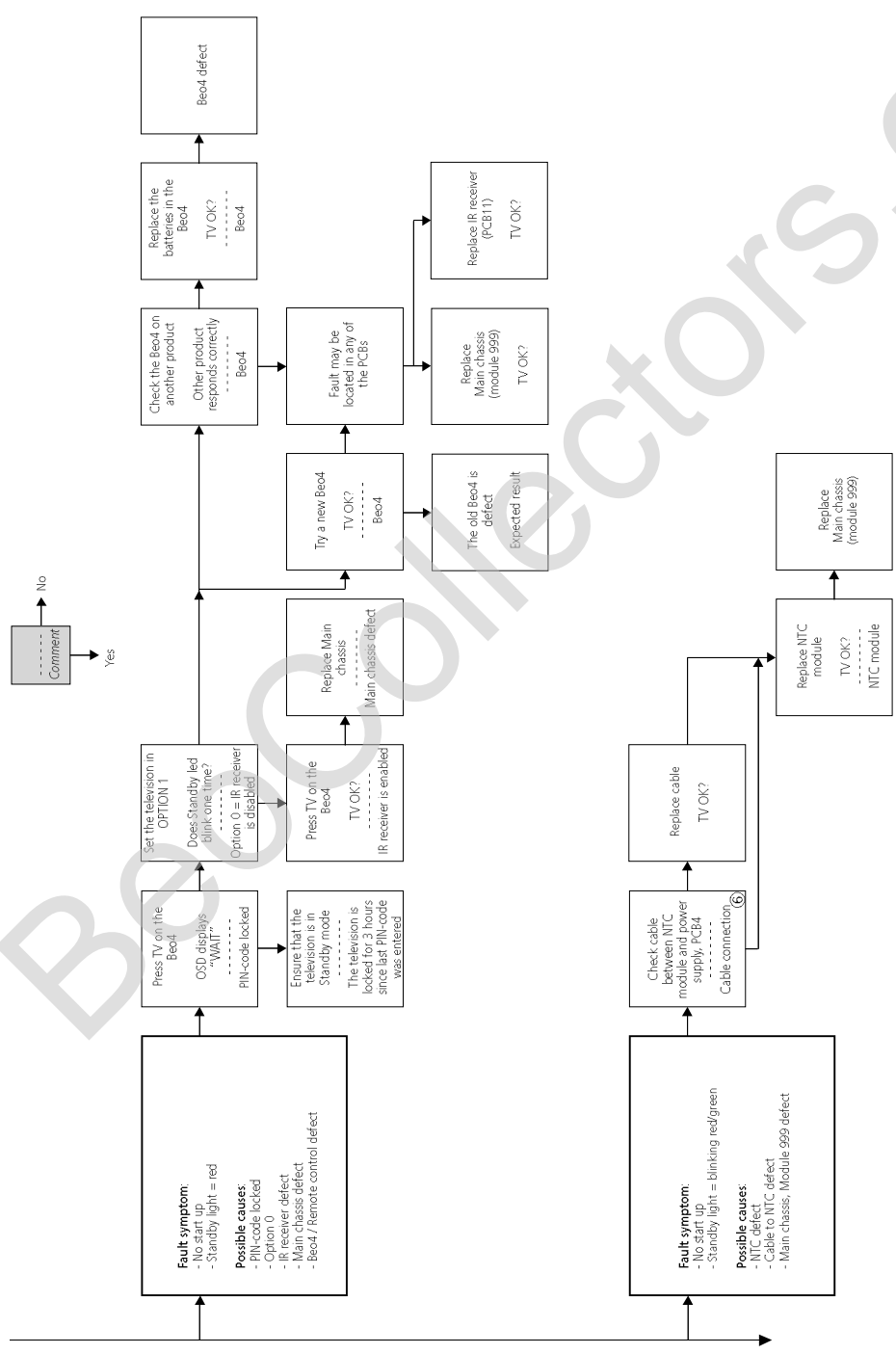

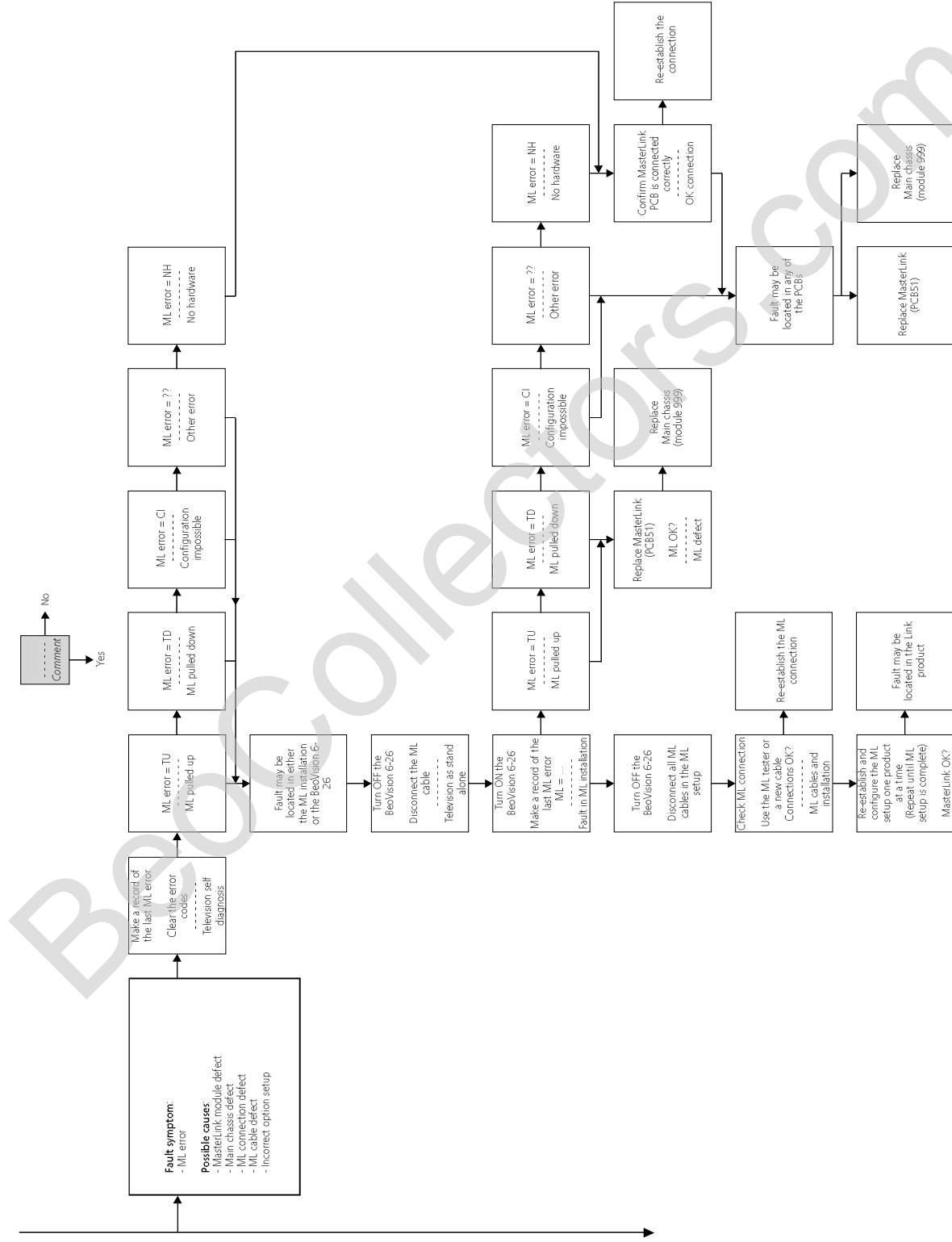

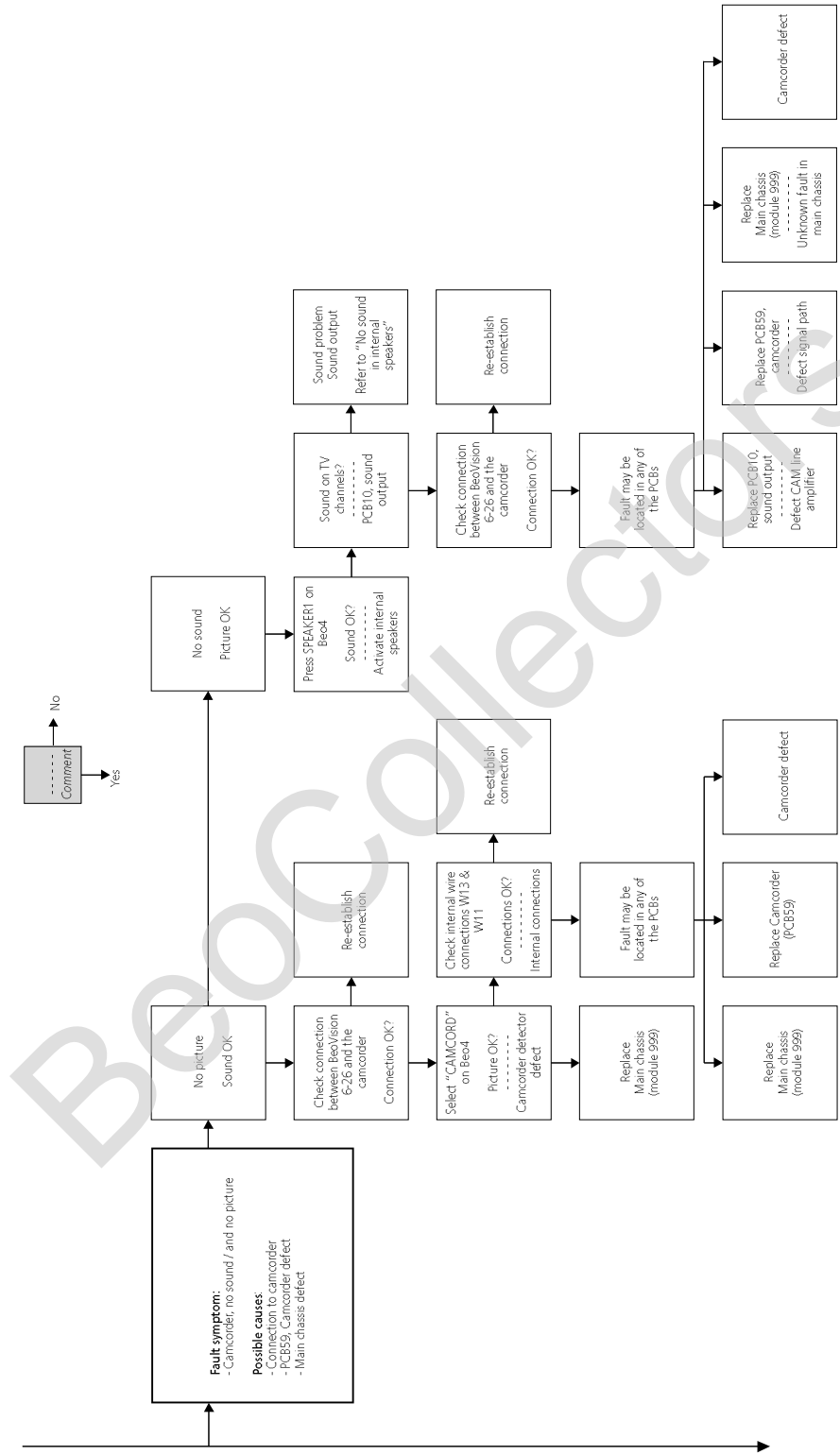

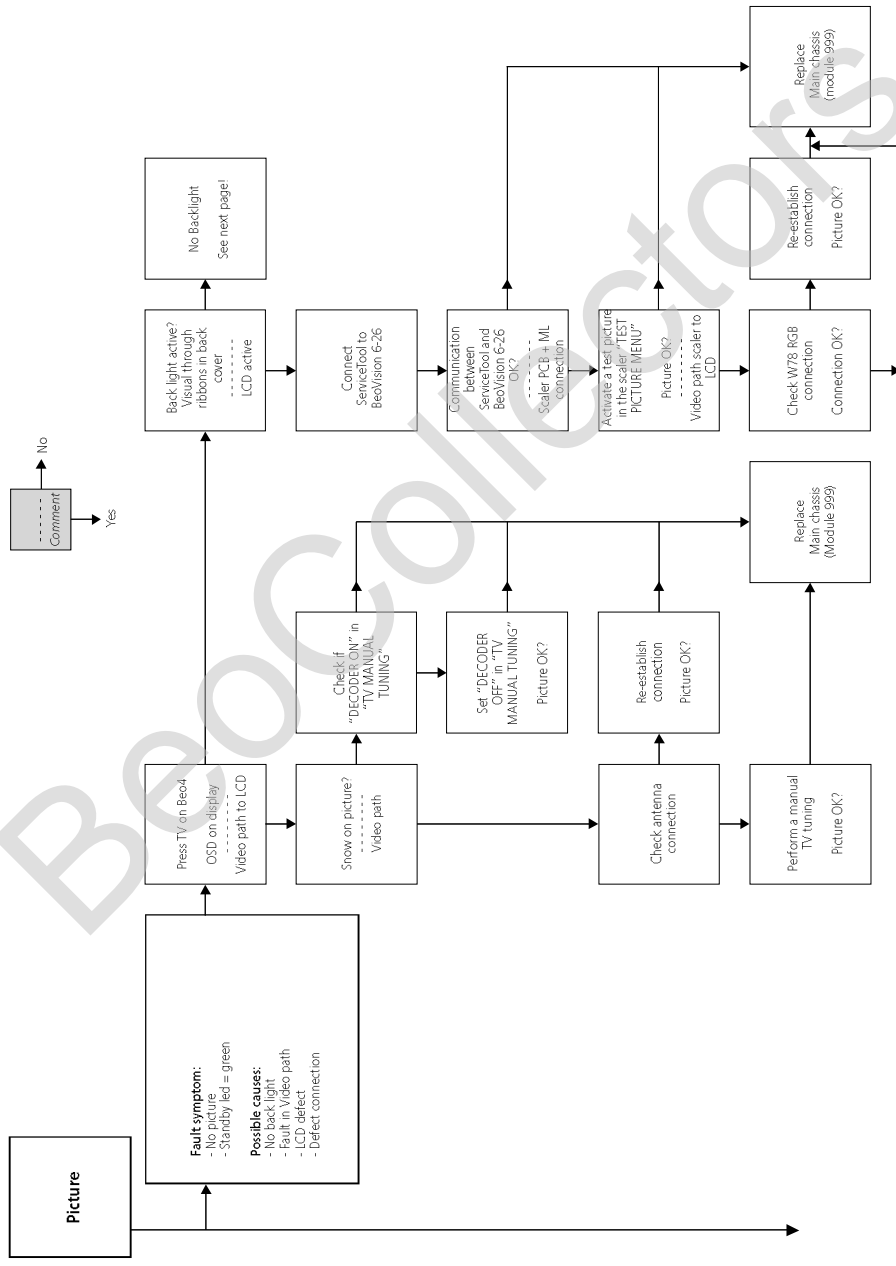

Comment

No

Yes

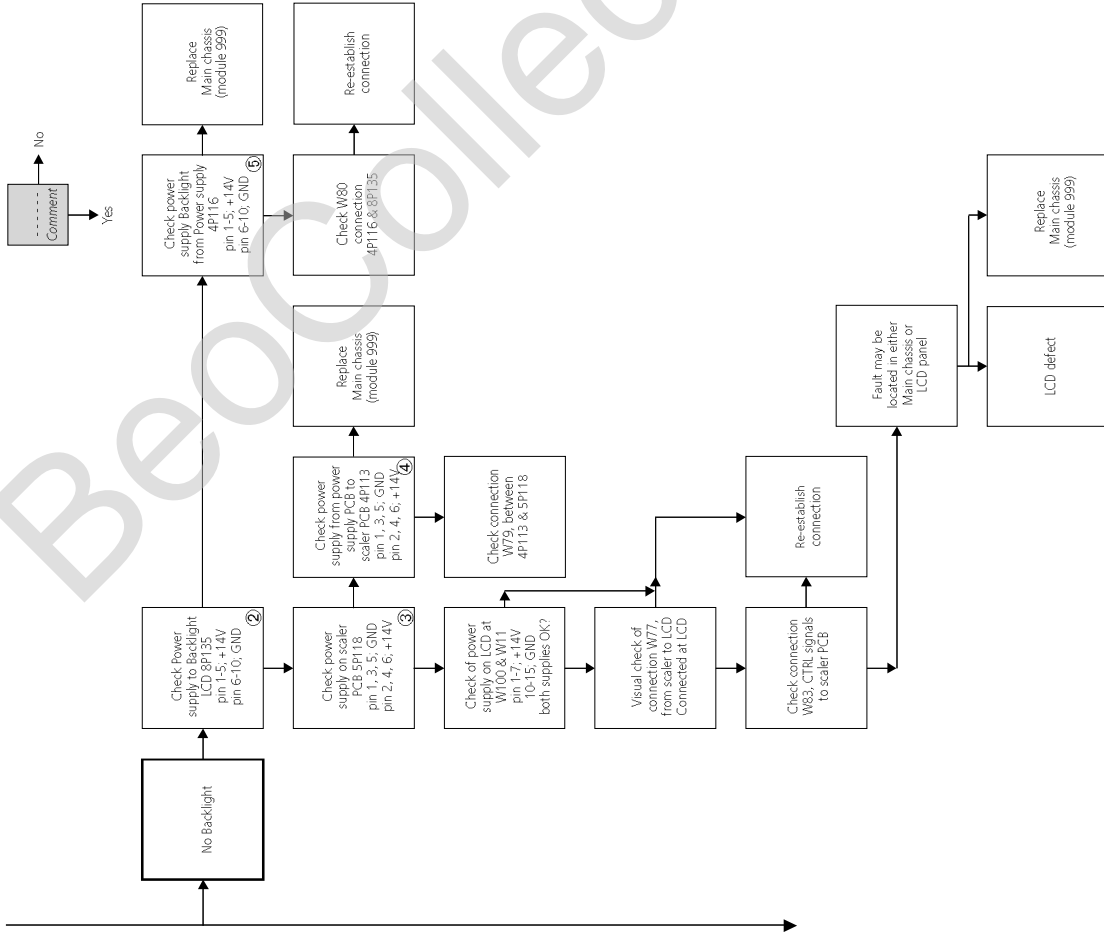

Comment

Yes

No

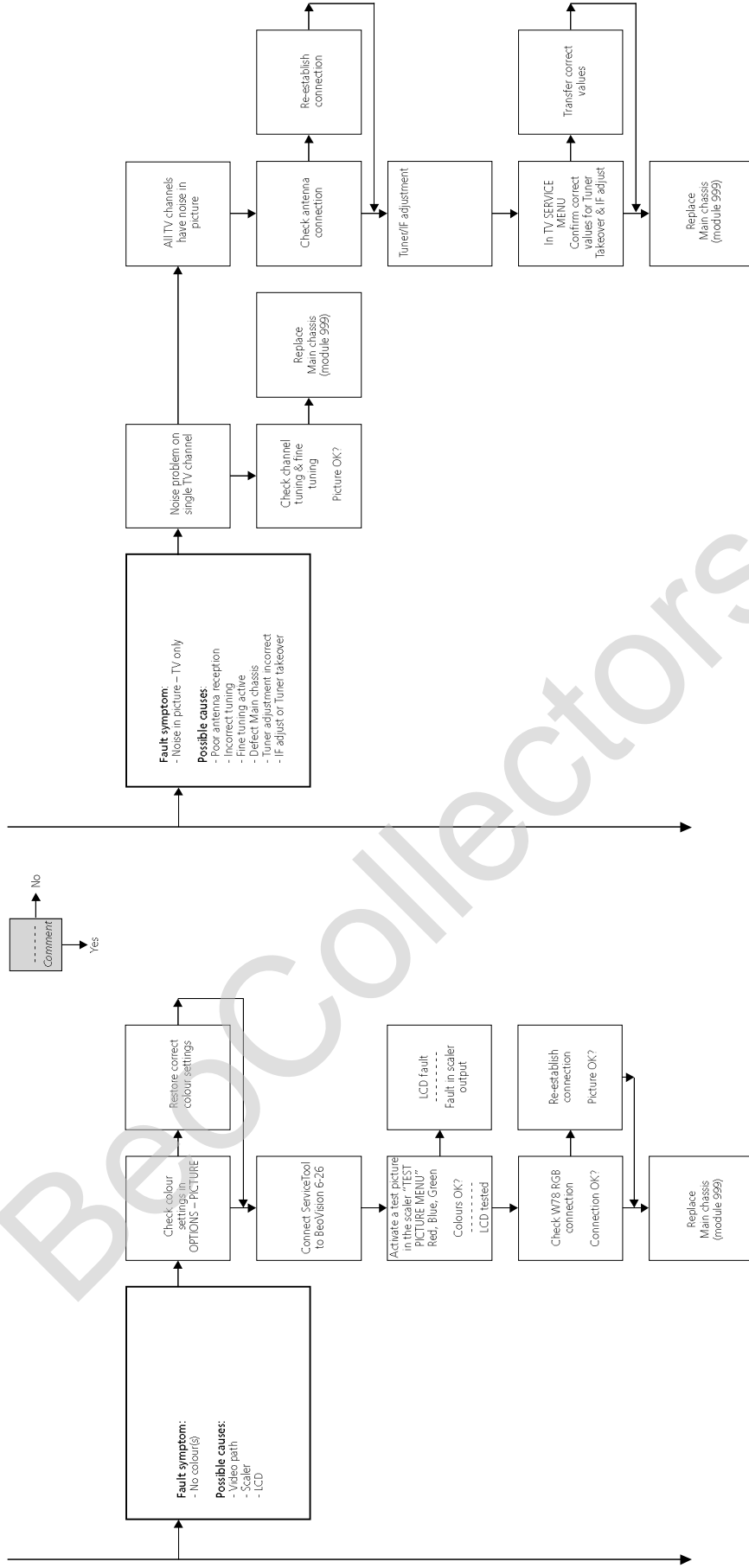

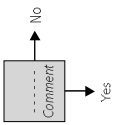
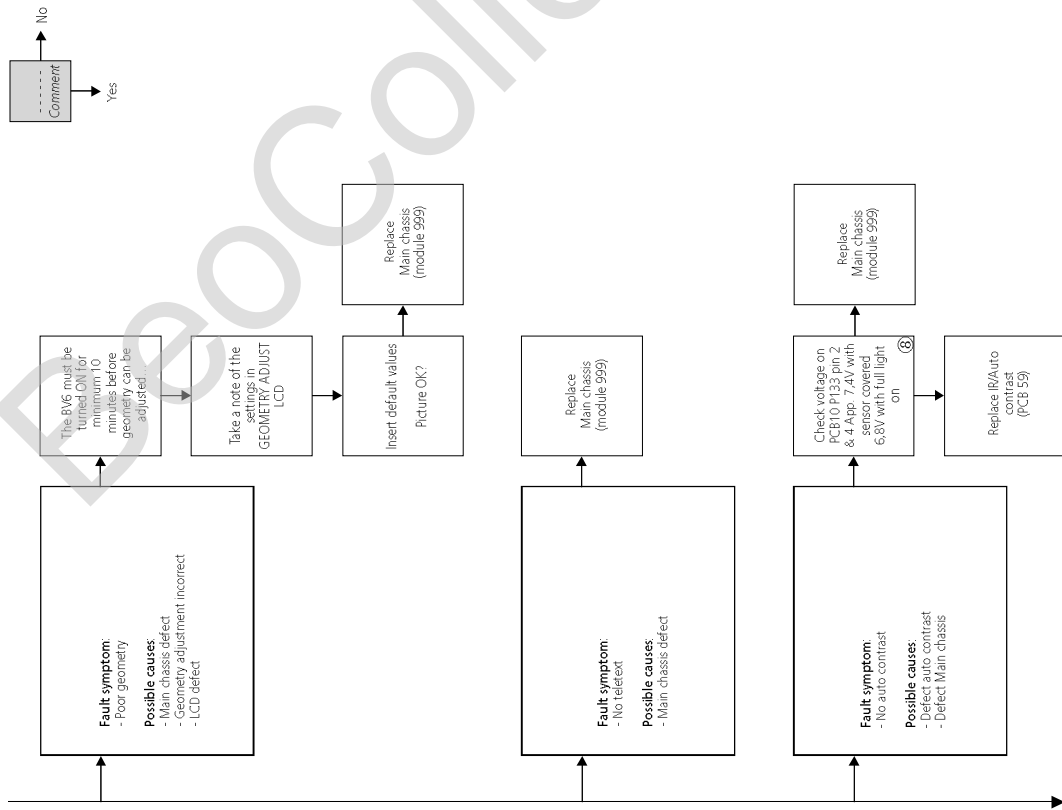

The BVC must be turned ON for minimum 10 minutes before geometry can be adjusted.

Take a note of the settings in GEOMETRY ADJUST LCD

Insert default values
Picture OK?

Replace Main chassis (module 999)

Replace Main chassis (module 999)

Check voltage on PCB10 P133 pin 2 & 4 App. 7.4V with sensor covered 6.8V with full light on

Replace I2C/Auto contrast (PCB 59)

Replace Main chassis (module 999)

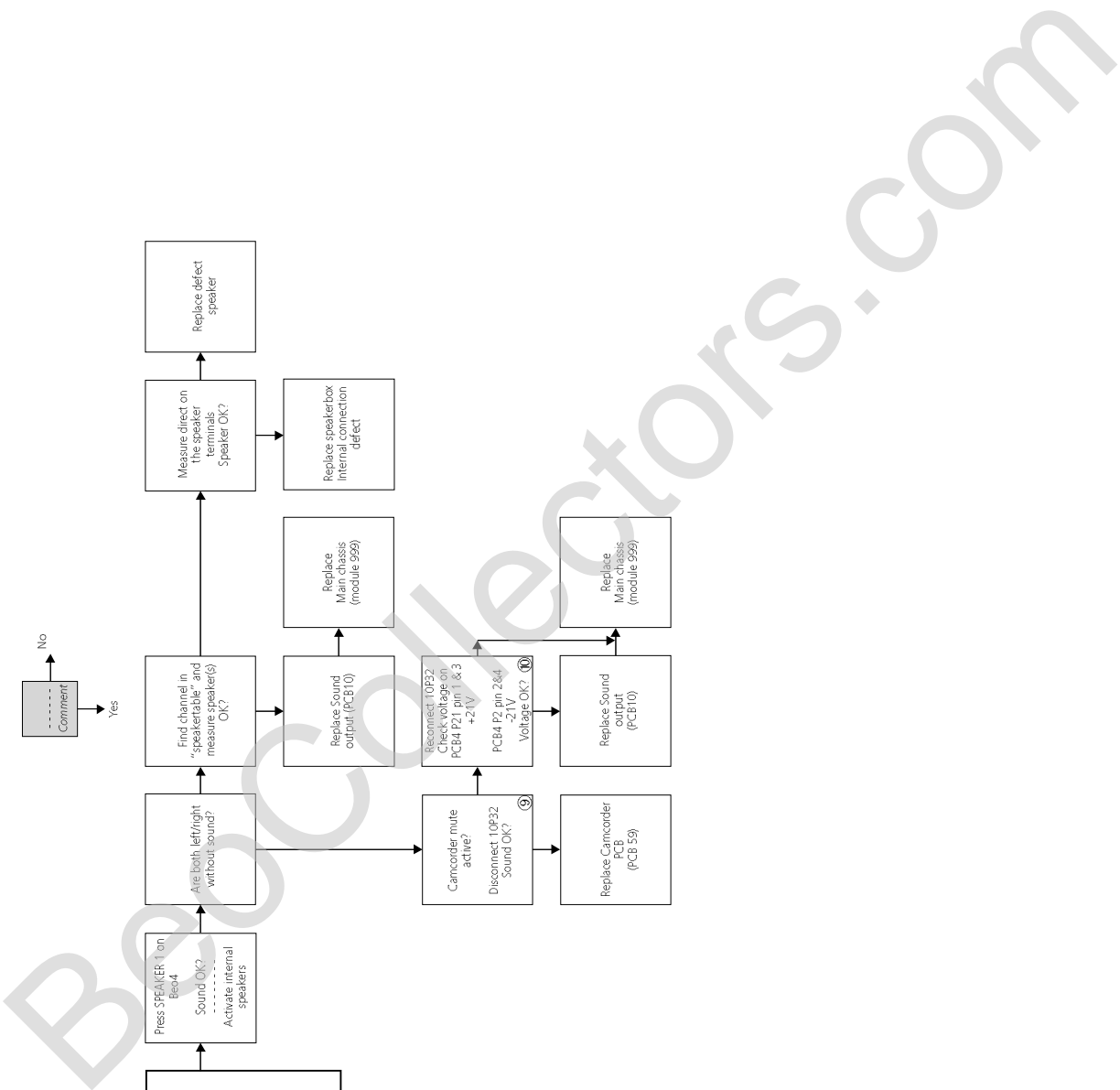
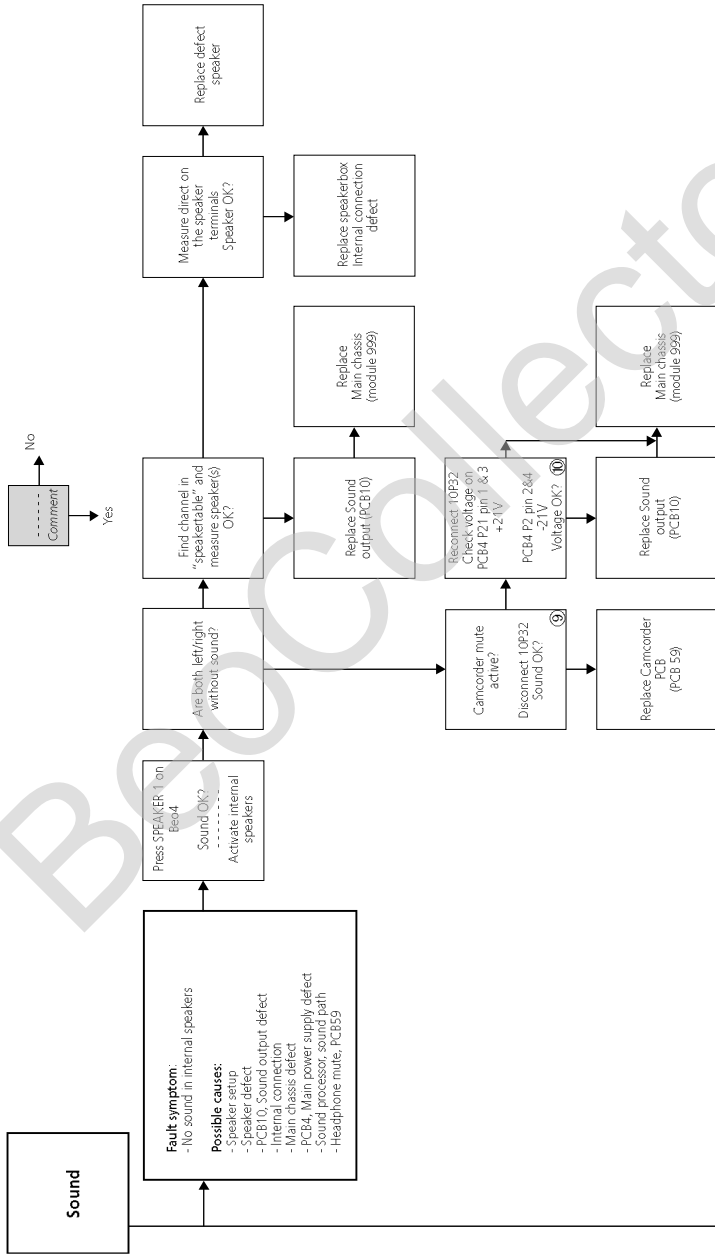

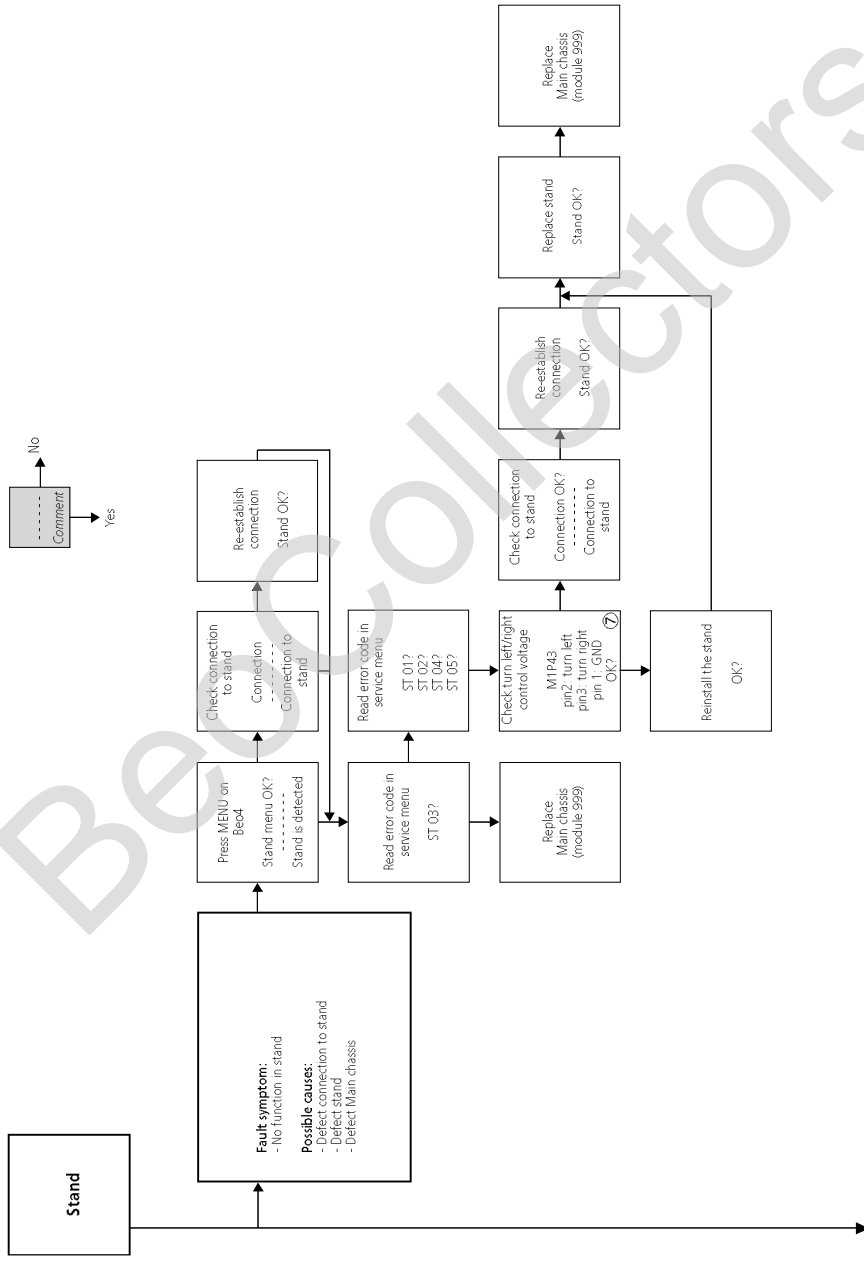

BeoCollectors.com

Placement of measuring points

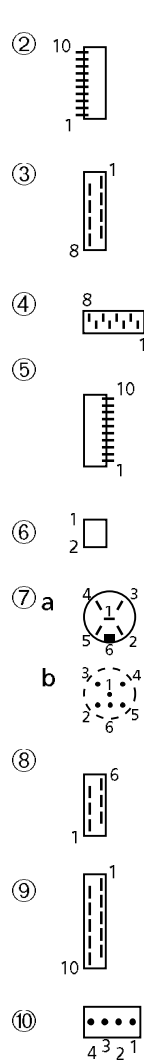

- ① Fuse on PCB4 (F220)
- ② Back light supply to LCD (8P135)
- ③ Scaler PCB power supply on PCB5 (5P118)
- ④ Scaler PCB power supply on PCB4 (4P113)
- ⑤ Back light power supply to LCD (4P116)
- ⑥ NTC connection (4P174)
- ⑦ Stand connection (1P43)
- ⑧ Light CTRL signal from PCB11 (10P33)
- ⑨ Camcorder connection (10P32)
- ⑩ Sound out power supply (4P21)

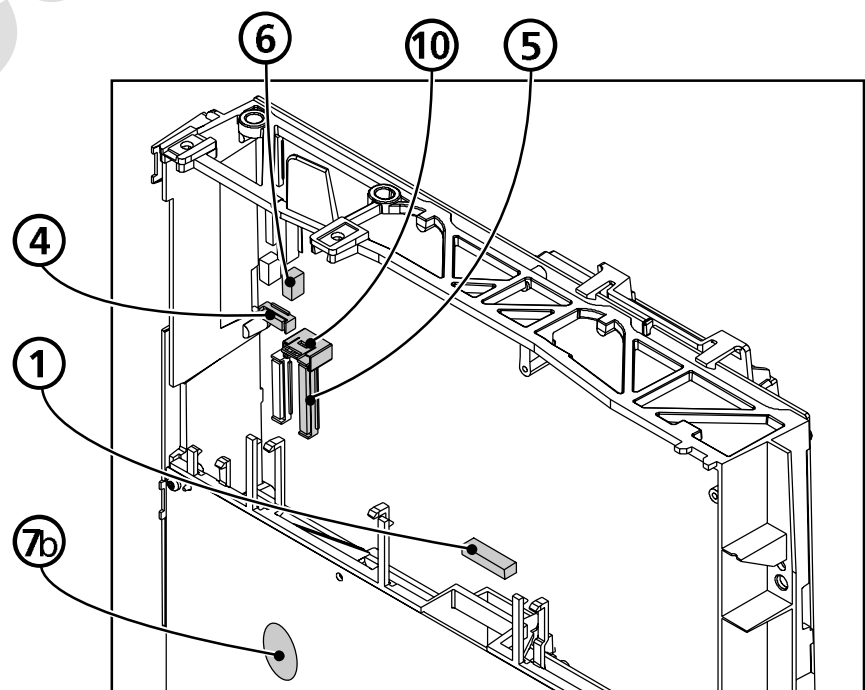
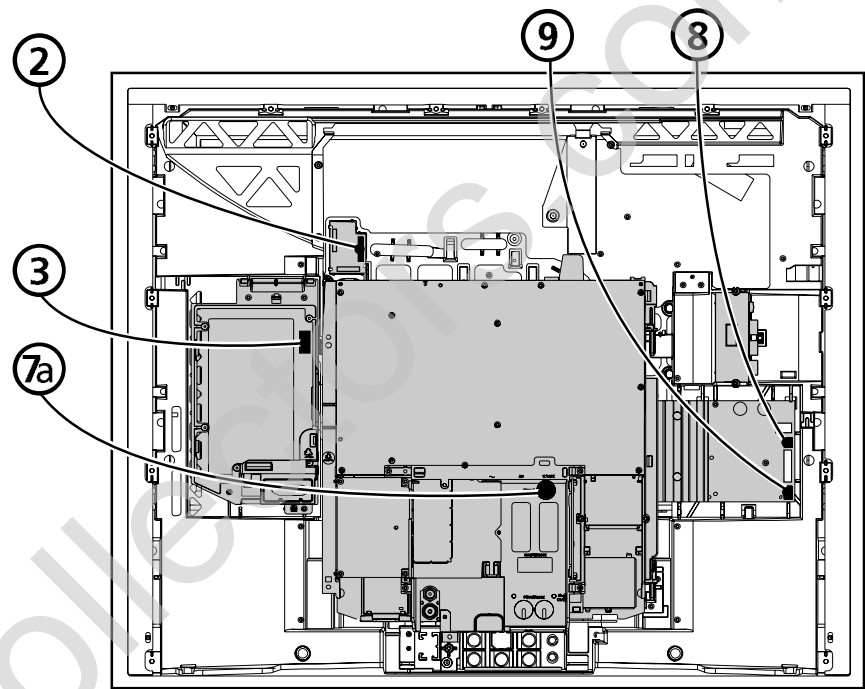

These tables are used in connection with fault-finding on BeoVision 6–26

Speakertable

No sound

- Find the channel and measure on the pins described, with multimeter in ohm's position. Resistance should be approx. 0 ohm. If not the speaker box should be replaced.

Channel			Pin no.
Left	Treble	10P45	5 - 3
Left	Bass	10P45	2 - 4
Right	Treble	10P31	4 - 2
Right	Bass	10P31	1 - 3

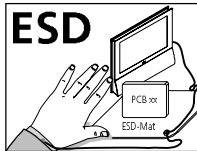

Please note:

When mains voltage on the product is required, remove the connection between the product and the ESD-mat.

Scaler test pictures

Access to Service Mode

Select TV SETUP menu
Beo4:: Press **0 0 GO** within 3 seconds

Access to the test patterns

Select MONITOR -> PICTURE ADJUSTMENTS -> SCALER TEST MENU -> TEST PATTERNS -> **GO**

Replacement of modules

Modules that can be replaced.

999	Main chassis, PCB 1, 4, 5, 6, 7, 64, 85	
LCD	LCD Panel	
8	Decoupling	illustrations only, page 8.8
10	Sound output	illustrations only, page 8.9
11	IR/Autocontrast	illustrations only, page 8.10
21*	DVB-S	illustrations only, page 8.11
32*	DSM	Illustrations only, page 8.12
51	Masterlink	illustrations only, page 8.13
59	Camcorder	illustrations only, page 8.14
63	System modulator	illustrations only, page 8.15
64	Powerlink	illustrations only, page 8.16
85	Mini Jack STB	illustrations only, page 8.17
* Optional modules		

Purpose of replacement of modules

Short instructions for replacement of the available modules, with reference to additional illustrations:

- the correct sequence for replacing modules.
- Text and illustrations.
- Reference to adjustment

Modules that do not require any special procedure may be shown as only illustrations.

Replacement of module 999, main chassis

For detailed dismantling instructions, please refer to illustrations on page 8.5

Notice

All modules must be placed on the ESD-mat or in an ESD-proof bag.

If the BeoVision 6 - 26 is mounted with Surround sound, DSM, the PL-module must be transferred from the new main chassis to defect main chassis.

On the new Main chassis, insert the two blind plugs instead of the PL output sockets.

Replace module 999

Replace using IC-pliers
(part no. 3629145)

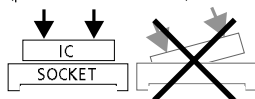

1. Set the product in Service position
2. Connect ESD-mat.
3. Remove DVB-S module if mounted
4. Disconnect cables and modules from the main chassis
5. Remove the main chassis and place it on the ESD-mat
6. Insert the new main chassis in the product
7. Transfer 6IC6, EEPROM, from the old to the new chassis
8. Remount modules and reconnect cables to the main chassis
9. Reconnect remaining cables

The product is now ready for adjustment.

10. Disconnect ESD-mat
11. Connect mains
12. Turn on the product

Enter TV Service menu.

13. Transfer the values for
Tuner Taker Over, IF adjust and FM Sound adjust.

Enter Monitor Service menu.

Check picture and geometry.

14. Check picture quality.
If picture quality is not OK, set HOP adjustment data to default.
Check picture quality again.

If picture quality is not OK, set ADC Adjustments, Scaler menu 1 & Scaler menu2
data to default.

If picture quality is not OK, contact Bang & Olufsen.
15. Geometry check.
If the geometry is not OK, set Geometry adjustment data to default.
16. Finish service.
See chapter "Final check after repair".

BeoCollectors.com

Replacement of LCD

For detailed dismantling instructions, please refer to illustrations on page 8.7

Notice

All modules must be placed on the ESD-mat or in an ESD-proof bag.

Replace LCD display

1. Set the product in Service position
2. Connect ESD-mat.
3. Disconnect cables connected to the LCD display.
4. Remove the LCD display, and place it on the ESD-mat.
5. Insert the new LCD display in the Television.
6. Reconnect cables to the main chassis

The product is now ready for adjustment.

7. Disconnect ESD-mat
8. Connect mains
9. Turn on the product

Enter Monitor Service menu.

Check picture and geometry.

10. Check picture quality.
If picture quality is not OK, set ADC Adjustments, Scaler menu 1 & Scaler menu2 data to default.

If picture quality is not OK, set HOP adjustment data to default.
Check picture quality again.

If picture quality is not OK, contact Bang & Olufsen.

11. Geometry check.
If the geometry is not OK, set Geometry adjustment data to default.

Confirm geometry is OK.
If geometry not OK, refer to "Adjustment«

12. Finish service.
See chapter "Final check after repair".

Adjustments

Adjustments described

Stand adjustment (if motorised stand connected).
 Tuner take over, IF adjustment & FM sound adjustment.
 Geometry check.
 Picture check.
 Sound adjustment, no adjustment possible.

Purpose of Adjustments

The content in the adjustment instructions are the following:

- Contains text and illustrations if needed.
- The correct sequence for adjusting the product.
- The correct procedure for the adjustment.

Illustrations of:

- Geometry measuring points

General considerations

- Correct adjustment of all parameters can only be obtained by using special test signals and equipment for light measurement.
- Factory settings will give the best result.
- Customer picture set up, Brilliance, contrast and colour are obtained in the TV SETUP – OPTIONS – PICTURE.

Picture adjustments

Brightness, Contrast and Colour can only be adjusted in the MENU – OPTIONS – PICTURE.
 The SERVICE MENU does not give this opportunity.

Measurements

All measurements concerning the geometry are measured with the contrast screen mounted.

Measurements are performed with a ruler, or by counting pixels.

For the best result, measurements are performed in a straight angle to the LCD panel, e.g. you see into the reflection of your own eye.

The television must be turned on for minimum 15 minutes before measurements may be started.

This is due to the back light that first is at 90% level after 15 minutes.

The test signal is applied to the V.TAPE input, SCART connector, unless other is specified.

Preparations before check and adjustment.

1. Turn the TV on.
2. The TV must warm up for minimum 15 minutes before adjustment may be performed.
 The back-light reaches 90% efficiency after app. 15 minutes
3. Select the correct test picture.
4. Set the TV in the correct FORMAT.

It is recommended to use the ServiceTool to download the settings.

Adjustment sequence:

1. Tuner take over, IF adjust and FM Sound adjust.
2. Stand, if connected.
3. Geometry check and adjustment if necessary.
4. Picture check and adjustment if necessary.

Access to Service Mode

Select a SETUP menu.

Beo4: Press **0 0 GO** within 3 seconds.

Select ordinary menu operation to leave Service Mode.

Operation in Service Mode.

Beo4	Activity
EXIT	Removes the menus
GO	- Selects the sub menu to the menu line where the cursor is placed - Stores the selected values and returns to the SERVICE MENU - Deletes error codes in the MONITOR INFORMATION menu and returns to the SERVICE MENU
▲	Moves the cursor up and returns to the previous menu
▼	Moves the cursor down and selects a sub menu in special occasions
◀▶	Selects new values in the menus and selects a sub menu in special occasions

Adjust Tuner takeover, IF adjust and FM sound adjust

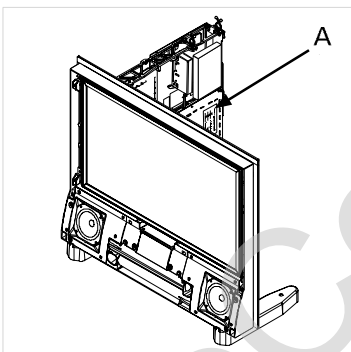

- The values (A) written on the label placed on PCB1, have to be written into the EEPROM (6IC6)

- Enter SETUP, select SERVICEMODE with **0, 0, GO**. Press the button combination within 3 seconds. Highlight TV-TUNER, select with **GO**. Change the settings by means of **◀▶** until they match the values on the label. Then press **GO** to store the settings.

Exit Service Mode.

Stand (Only TV with motorised stand)

The scope of this adjustment is to determine the center position.

The adjustment must be performed in the following situations:

- the motorised stand is connected to the television.
- the main chassis has been replaced.
- the EEPROM (6IC6) has been replaced.

Adjustment procedure

1. Enter the SERVICE MENU and select STAND.
2. Press **GO**, when CALIBRATION OK is displayed, the center position of the motorised stand is found.

Geometry adjustment

Geometry adjustment is normally not necessary.
The geometry may be checked.
It is recommended to use a tv test picture, test tape part no: 6780000.
Geometry specification is placed in section 9.1.

It is possible to adjust the size and position in the SERVICE MENU - GEOMETRY ADJUSTMENTS.

Geometry is adjusted in FORMAT 1 and the values for all other picture formats are calculated.

The picture format 4:3 must be enabled in SERVICE MENU - TELETEXT & FORMAT ADJUST.

Geometry Adjustment procedure.

1. Check the geometry specifications in FORMAT 1.
FORMAT 1, 15:9
FORMAT 1, 4:3
FORMAT 2, 15:9 Letterbox
FORMAT 3, 16:9 - use the 4:3 testpicture.
2. If geometry adjustments are within specifications no adjustment is necessary.
3. Insert/adjust the default factory values in FORMAT 1 if necessary.

Geometry default factory values:

HOR SIZE 980
VERT SIZE 548
HOR POSITION 103
VERT POSITION 11

Remember to disable picture format 4:3.

Geometry specifications 9.1

FORMAT 1, 15:9
FORAMT 1, 4:3
FORMAT 2, 15:9 letterbox
FORMAT 3, 16:9

Picture adjustments

Correct adjustment of all parameters can only be obtained by using special test signals and equipment for light measurement.
Adjustment of the specific parameters are not described

Picture setting (TV – MENU – OPTIONS – PICTURE)

Brightness	Contrast	Colour
Middle position (32)	Middle position (32)	Middle position (32)

Picture adjustments

1. Check the picture quality.
2. If adjustment is necessary, insert default factory values.
3. Confirm the picture quality.

Default factory values

		Default factory	Actual value
HOP Picture menu	<u>HOP settings</u>		
	Brilliance	7	
	Colour	19	
	Contrast	32	
	Red Drive	7	
	Green Drive	7	
	Blue Drive	5	
	Black Offset R	6	
	Black Offset G	8	
	Soft Clip	0	
	PWL	2	
ADC Adjustments	R Offset	0	
	R Coarse	58	
	R Fine	0	
	G Offset	0	
	G Coarse	58	
	G Fine	0	
	B Offset	0	
	B Coarse	58	
	B Fine	0	
	H SYNC	144	
Scaler Menu 1	<u>Picture Offsets</u>		
	Brightness	12	
	Colour	22	
	Contrast	70	
	Scaler Contrast	148	
	<u>Current Values</u>		
	Brighthness		
	Colour		
	Contrast		
	Backlight		
	TINT		
Scaler Menu 2	<u>Display White Point</u>		
	Display R	124	
	Display G	128	
	Display B	115	
	<u>Lookup Table Selection</u>		
	Red Table	0	
	Green Table	0	
	Blue Table	1	

Final check after repair

Final check after repair

The final check after repair, describes the activities that are needed to ensure the product will be returned in perfect condition to the customer.

The contents is:

- AC leakage test.
- Check product information.
- Restore the setup and check connections, picture and sound.
- Final cleaning of the product.
- PIN-code setting

Insulation test

Each set must be insulation tested after having been dismantled. Make the test when the set has been reassembled and is ready to be returned to the customer. *Flashovers must not occur during the testing procedure!*

Make the insulation test as follows:

Short-circuit the two pins of the mains plug and connect them to one of the terminals of the insulation tester. Connect the other terminal to ground on the aerial socket.

NOTE!

To avoid damaging the set it is essential that both terminals of the insulation tester have good contact.

Slowly turn the voltage control of the insulation tester until a voltage of 1.5 kV and max. 10mA is obtained. Maintain that voltage for one second, then slowly turn it down again.

Monitor information

The scope of this check is, to ensure the following:

- The product has maintained the correct identity.
- Is set to correct option
- The error code register is cleared

Procedure

1. Enter Service menu – monitor service menu – monitor information
2. check the serial number is correct
3. check option setting is correct
4. clear the error code.
5. select error code and press **GO**.

Customer setup

Remember to inform the customer of any changed that has been made in the user setup, due to procedures in the ossg, such as Connections, Sound, Picture, etc.

Restore the product to the customer setup.

TV SETUP - OPTIONS

Connections, such as DVD, STB, VTR

Sound, such as external speakers

Picture

Clock

Check all sources are working correctly

- Check that picture and sound on all sources are working correctly.
- Check the teletext are working correctly.

Clean the product.

Never use alcohol or other solvents to clean any part of the television.
Use a soft, lint-free cloth to clean the surfaces of the television.

Contrast screen.

To avoid soiling the speaker cover when you clean the television screen or the LCD, we recommend that you remove the speaker cover beforehand.

Use white gloves to avoid smudging the contrast screen.
The illustrations are places in the back. See page 8.4

To clean the contrast screen or the LCD, use a mild window cleaning fluid. To retain the optimum performance of the screen, make sure that no streaks or traces of the cleaning fluid are left on the screen or the LCD.

Cabinet surfaces

Wipe dust off the surfaces using a dry, soft cloth. Remove grease stains or persistent dirt with a soft, lint-free, firmly wrung cloth, dipped in a solution of water containing only a few drops of mild detergent, such as washing-up liquid.

Speaker cover cleaning instructions

Please refer to the user guide.

PIN-code

Please refer to the user guide for further information about the use of PIN-code

Information to the customer

The PIN-code must be activated by the customer.

BeoCollectors.com

Service menu

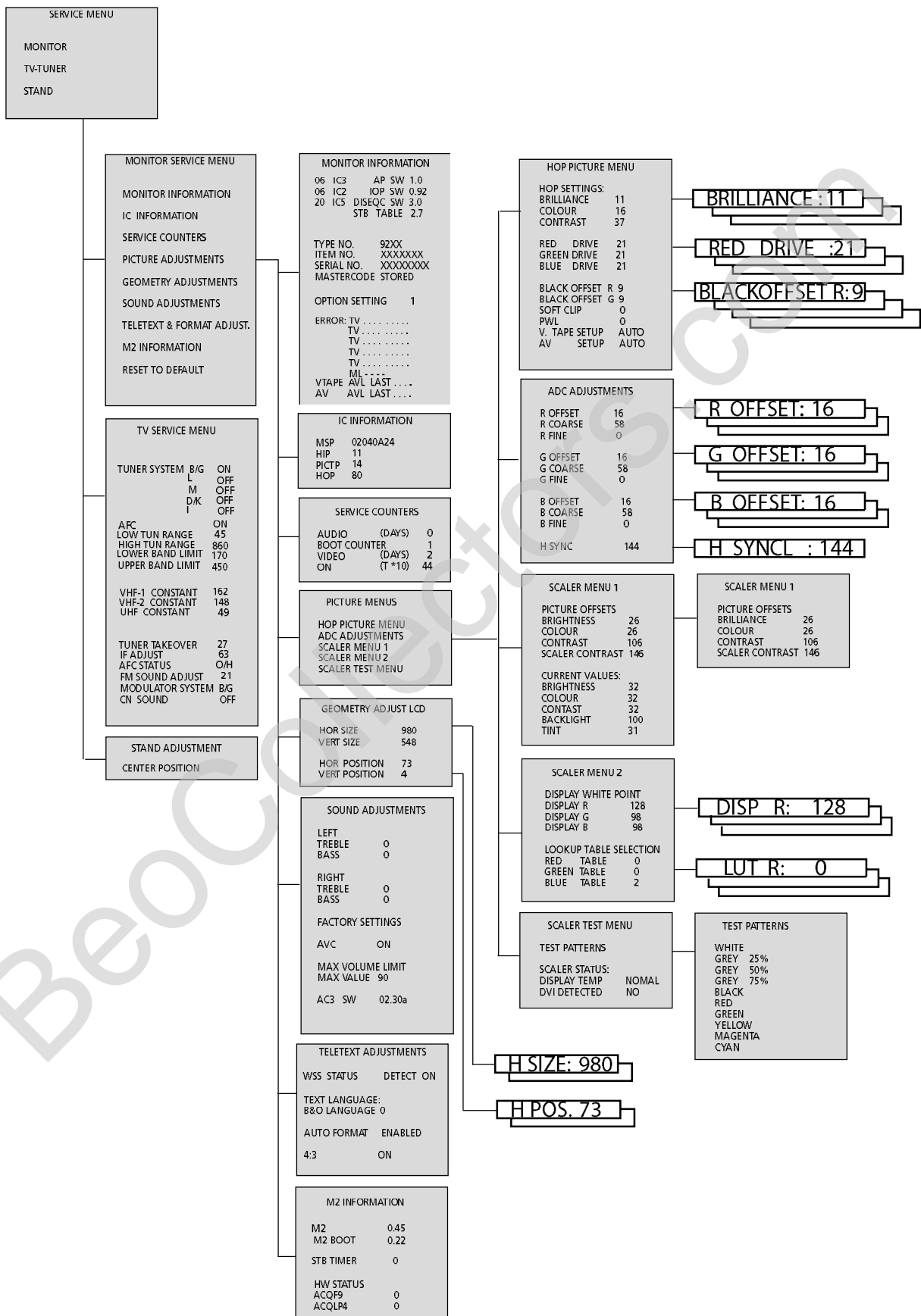

Service Mode

The Service Mode consists of two parts: Service menu and ignore mode. On page 5.1 see an overview of the Service Mode menus, and operation in Service Mode.

SERVICE MENU

The STAND line is only shown if the TV is fitted with motorized stand. The function is described in the section on adjustments.

MONITOR SERVICE MENU

The PICTURE ADJUSTMENTS and GEOMETRY ADJUSTMENTS lines are described in the section on adjustments.

MONITOR INFORMATION

- Software version numbers
The DISEQC line is only shown if the TV is fitted with a DVB-S module.
The "STB TABLE 1.0" line shows the version of conversion of set top box remote control codes into Beo4 codes. The line is only shown if the M2 processor has been flash programmed.
- Type, item and serial numbers
- PIN-code status. Shows if the Master code is correctly entered (STORED/NOT STORED)
- Option programming
- Latest five TV errors
- Latest ML error
- Latest AVL error from the V.TAPE and AV sockets

OPTION SETTING

- Option 0 = The IR receiver of the TV is disconnected.
- Option 1 = The TV and the Audio system (BeoLink system) are placed in the same room.
- Option 2 = The TV and the Audio system (BeoLink system) are placed in different rooms.
- Option 4 = Two TV's in the same room and the TV's are not linked together.
- Option 5 = The TV and the Audio system (BeoLink system) are placed in the same link room.
- Option 6 = The TV is the only product in the link room.

ERROR:TV

The TV is able to detect certain types of error and display them on the screen. The five latest TV errors are shown as error codes and displayed with the month/date (four digits) as provided by the system clock. The most recent error is displayed at the top. As the TV has no hardware clock the displayed month/date will not be correct, but can be used to see if more errors have occurred at the same date.

The following TV error types can be displayed:

- No error registered
- DF Data failure
- POR1 Power on reset failure 1
- POR2 Power on reset failure 2
- PDD Power down detected failure
- DPF DiSEqC power fail.
- XX-YZ (XX = IIC address
Y = IIC bus 1 or bus 2
Z = any IIC bus segment A/B/C/D)

ML error codes are for detection of errors in the Master Link system.

. . . . No error registered
 CI Address configuration impossible
 TD ML data pulled down
 TU ML data pulled up
 ?? Other undefinable error possibilities
 NH No Hardware. There is no Master Link PCB in the TV

AVL error codes from the V.TAPE and AV sockets

. . . . No error registered
 TI Transmission impossible
 TD Data link tied down

Motorized stand error codes

ST-01 Calibration error too few positions
 ST-02 Calibration error too many positions
 ST-03 Calibration error EEPROM
 ST-04 Calibration error transducer
 ST-05 Calibration error position

After repair of an error that has triggered the display of an error code, the error code has to be deleted. This is done by pressing **GO** in the MONITOR INFORMATION menu.

IIC bus error

An IIC bus error means that the communication on the bus fails when the microcomputer tries to communicate with the address in question.

Error code	Module	IC	Function	On modes	Clock	BUS
22	1	IC200 SDA6000	M2 Processor	AV	400 kHz	IIC-2D
40	1	IC300 TDA9178	CTI	V	400 kHz	IIC-3_2
60	6	IC2 H8/3216	IOP Main processor	SAV	400 kHz	IIC-2D
80	1	IC550 MSP3410D	Sound processor	AV	100 kHz	IIC-2C
80	64	IC2 TDA7315	Power Link	AV	100 kHz	IIC-2B
84	32	IC601 H8/3214	Digital Sound Module	AV	100 kHz	IIC-1
8A	1	IC100 TDA9321H	Colour decoder & IF (HIP)	AV	100 kHz	IIC-2A
8C	1	IC350 TDA9330H	Video processor (HOP)	V	100 kHz	IIC-3_2
A2	1	IC49 PCF8563	Real-time clock	SAV	100 kHz	IIC-1
C0	1	TU1 CTF5510	TV tuner	V	100 kHz	IIC-2A
C8	63	IC1 TDA8722M	Modulator	AV	100 kHz	IIC-2A

In most cases this means that the addressed IC is defective but the defect could also be in one of the components surrounding the IC or in other components on the bus. Addresses in connection with IIC bus errors:

On modes:

S - Standby mode
 A - Audio mode
 V - Video mode

DF Data failure

If an error occurs in the EEPROM (6IC6) that prevents output of geometry data to the TV set, the microcomputer will replace the missing data with default data stored in the EPROM (6IC3) module 999.

- POR1 Power on reset failure 1**
Reset or update failure of 1IC100 (TDA9321H module 999) during start up.
- POR2 Power on reset failure 2**
Reset or update failure of 1IC350 (TDA9330H module 999) during start up.
- PDD Power down detected failure**
Power down failure detected on 1IC300 (TDA9178 module 999).
- DPF DiSEqC power fai**
Power fail on the DVB-S module.
- CI Address configuration impossible**
Error during address configuration. No address has been allocated because an excessive number of units has been connected to the Master Link.
- Disconnect all units from the link and reconnect them again one at a time.
- TD ML data pulled down**
The link is pulled down (Low). This error can occur in the form of a physical short circuit in the link. In the link drivers, or in the ML master/source circuit module 51 in the TV.
- TU ML data pulled up**
The link is pulled up (High). This error can occur in the form of a physical short circuit in the link. In the link drivers, or in the ML master/source circuit module 51 in the TV.
- TI Transmission impossible**
It is not possible to send data to pin 8 on the V.TAPE or AV socket, probably because of noise.
- TD Data link tied down**
The data link connection to pin 8 on the V.TAPE or AV socket is short circuited to ground.
- ST-01 Calibration error too few positions**
Not enough positions are read during Stand calibration. The Stand may be blocked.
- ST-02 Calibration error too many positions**
Too many positions are read during Stand calibration.
- ST-03 Calibration error EEPROM**
Failure when the Stand offset should be stored in the EEPROM.
- ST-04 Calibration error transducer**
An invalid position is read from the transducer.
- ST-05 Calibration error position**
Several readings from the transducer with the Stand in the same position.

IC INFORMATION

Shows the version numbers for the IC's mentioned.

MSP = 1IC550 (MSP3410D), HIP = 1IC100 (TDA9321H)

PICTP = 1IC300 (TDA9178), HOP = 1IC350 (TDA9330H)

SERVICE COUNTERS

AUDIO = audio mode, the EHT voltage is off.

BOOT COUNTER = shows how many times the set has been connected to the mains voltage.

VIDEO = audio/video mode.

ON (T*10) = shows how many times the set has been turned on from stand by.

(T*10) = The numbers are stated in interval of 10 (e.g. 10 = 100).

The number is given in full tens.

The values are stored in the EEPROM. If faulty readings of the values in the EEPROM occur all service counter values will be set to 0.

SOUND ADJUSTMENTS

LEFT and RIGHT TREBLE/BASS are for future use.

AVC = Automatic Volume Control, can be set to OFF when measuring in the audio circuits. The AVC is set to ON when the TV has been turned off by means of the mains switch.

- MAX VOLUME LIMIT: Can e.g. be used to limit the max. volume regulations on TV's placed in hotel rooms.
- The AC3 SW line is only shown if the TV is fitted with an AC3 module.

TELETEXT ADJUSTMENTS

WSS STATUS: Some TV broadcasters transmit a picture format identification, enabling the TV to switch to the proper format automatically when WSS DETECT is ON if there is WSS codes in the signal.

BROADCAST ONLY: Only switching on signal from the TV tuner.

DETECT ON: Switching on signals from all sources TV tuner, DVD playback, V TAPE and AV sockets.

DETECT OFF: Used under certain conditions, e.g. a poor signal-to-noise ratio, the detection may fail, which may entail faulty swithing.

Selecting "B&O LANGUAGE" makes it possible to choose among 7 different teletext character sets.

- 0 English, German, Swedish, Italian, French, Portuguese, Slovak
- 1 Polish, German, Swedish, Italian, French, Croatian, Slovak, Rumanian
- 2 English, German, Swedish, Italian, French, Portuguese, Turkish
- 3 English, Russian, Estonian, Czech, German, Lithuanian, Ukrainian
- 4 English, German, Swedish, Italian, French, Portuguese, Turkish, Greek
- 5 English, Arabic, French
- 6 English, Hebrew, Arabic

If language 3 to 6 are choosen it is not possible to receive teletext level 2.5 d/r/c/s characters.

If language 3 to 6 are choosen it is not possible to make animation in the programme list in teletext mode.

AUTO FORMAT ENABLED

It is possible to get a 4:3 picture in Format 1 if 4:3 is set to ON.

M2 INFORMATION

- Software versions for the teletext processor 11C200 SDA6000.
- STB TIMER: Is default set to 0 but can be altered if timing problems occurs during start up with certain Set Top Boxes.
- HW STATUS: For factory use.

RESET TO DEFAULT

When this line is selected the settings will be defined.

- All TV and radio programmes are cleared.
- The V.TAPE and AV sockets are set to NONE.
- In the PICTURE ADJUSTMENT service menu the values for brilliance, colour and contrast are set to default.
- All programme lists are cleared.
- The TV SETUP TUNE menu will be shown the first time the TV is switched on.
- OPTION is set to 2.
- The PIN-code setup is not changed.

When RESET TO DEFAULT is selected a text "PLEASE WAIT 30 SEC." is displayed. While the text is displayed no operation must be done. When the text disappears Service Mode is exited.

Set the TV into St. by.

TV SERVICE MENU

In TUNER SYSTEM it is possible to set only relevant tuner systems to ON (only multi standard TV's). This is done to reduce the tuning time.

AFC ON/OFF is used in connection with adjustments but it may also be useful in other situations.

The AFC is set to ON when the TV has been turned off by means of the mains switch.

CN SOUND (ON) / OFF

Used to compensate for different sound modulation levels from TV transmitters in China.

Normally the frequency deviation is 100 kHz, but in China some TV transmitters are transmitting "Wide Sound" which has a frequency deviation of 360 kHz. This results in bad sound - distortion - because of the higher modulation level. To compensate for this CN SOUND must be set to ON.

The function is only working in combination with the tuner system D/K.

If the function is set to ON with other tuner systems it will not influence the sound.

LOW TUN RANGE	45
HIGH TUN RANGE	860
LOWER BAND LIMIT	170
UPPER BAND LIMIT	450

VHF-1 CONSTANT	161
VHF-2 CONSTANT	146
UHF CONSTANT	52

These items are for factory use.

TUNER TAKEOVER	26
IF ADJUST	8
AFC STATUS	O/H
FM SOUND ADJUST	14
MODULATOR SYSTEM	B/G

These items are described in the section on adjustments.

Bus ignore mode

If an error occurs in the IIC bus system which makes the TV go into stand by every time it is attempted to be switched on, it is possible to switch on the TV in such a way that the error is ignored:

- The TV must be in stand by.
- Short-circuit the two solder pads (marked J40 coordinate 11A on PCB1).
- Press **TV**. The TV will now start up in bus ignore mode with service menu if possible.
IMPORTANT! If the TV is started up in ignore mode it may result in further damage to the TV.
- Exit ignore mode. Turn off the TV.

ServiceTool

Considerations before connecting the ServiceTool to the product

- Disconnect the product from the Mains supply.
- Follow the instructions described in the ServiceTool.

Contents in Servicetool

The ServiceTool will contain the complete information concerning:

- How to connect the ServiceTool to the product.
- List of functions handles by the ServiceTool.
- Instruction for using the functions.

The ServiceTool does not contain:

- Description of access and connection to internal connectors inside the product.

BeoCollectors.com

Mounting servicestands

Remove socket cover

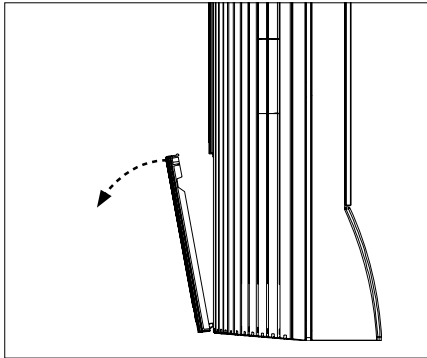

Correct mounted service foot

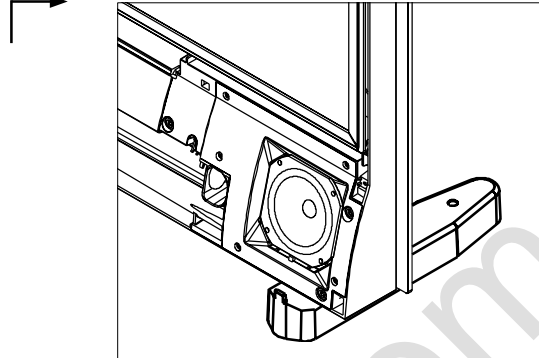

Remove cables

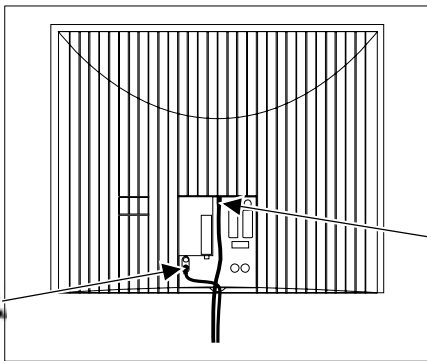

Pull of speaker cover

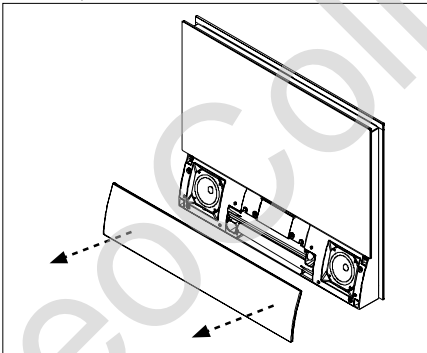

Mount service feet

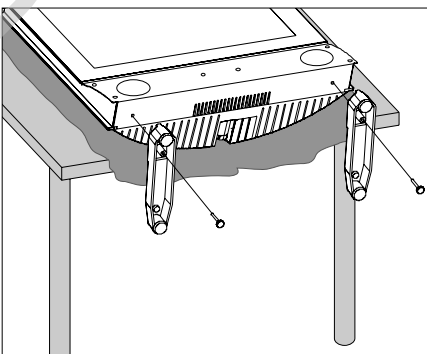

BeoCollectors.com

Service mode

6.1 Mounting servicestands

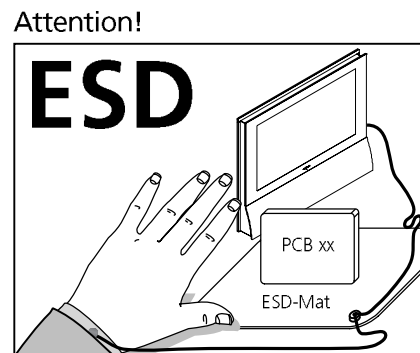
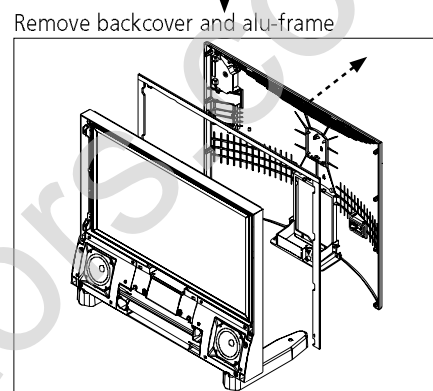
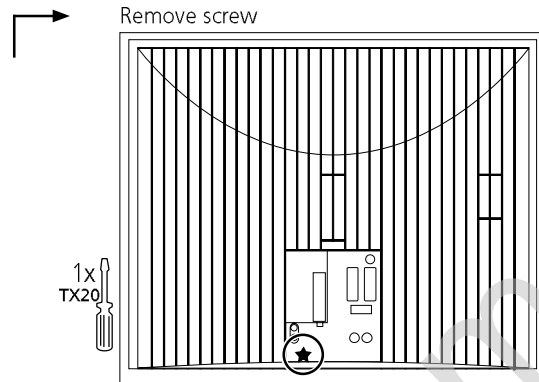
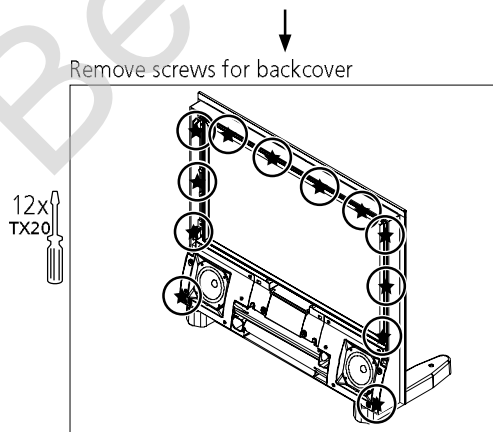
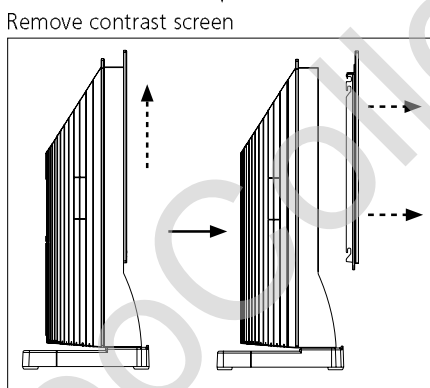
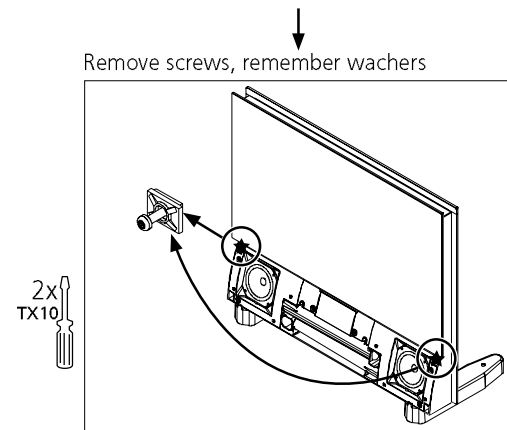

Main chassis in service position

➔ 6.2 Service mode

Attention!

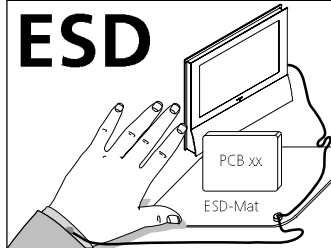

Open chassis 90°

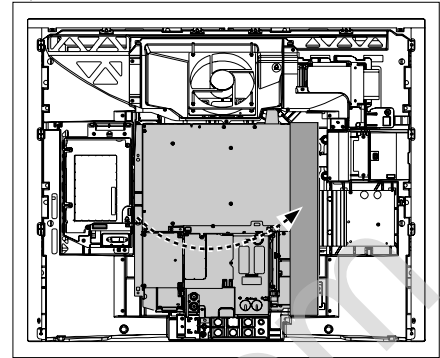

Remove screws on right side

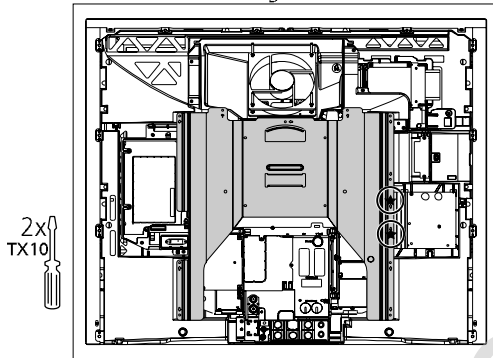

Remove screws and remove shield

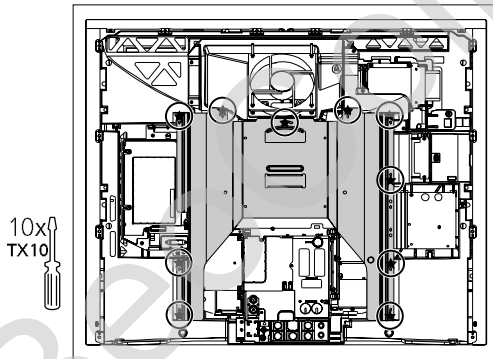

Remove screws on chassis

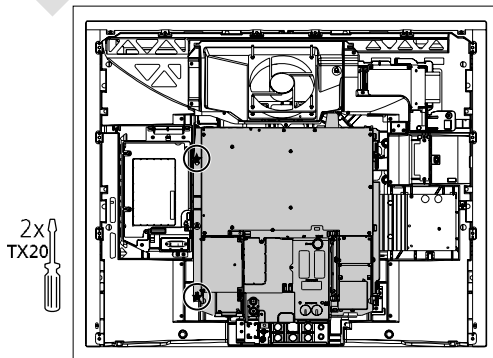

Removing speaker cover

Pull of speaker cover

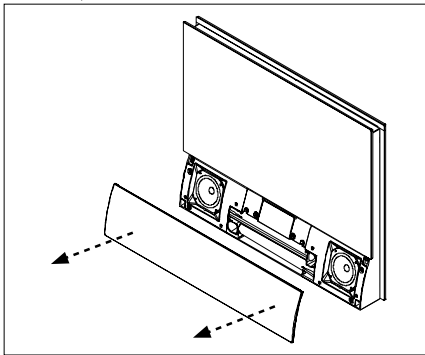

Removing contrast screen

Remove screws, remember washers

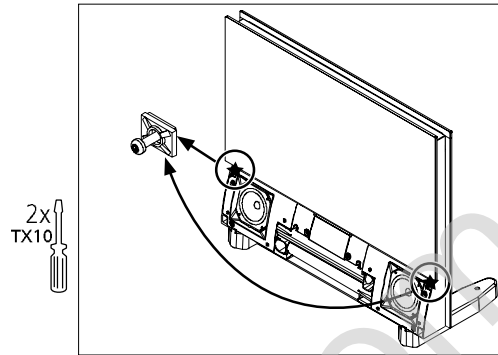

Remove contrast screen

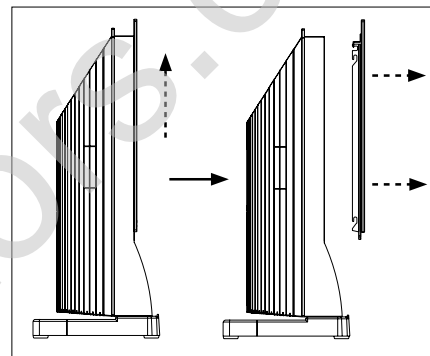

BeoCollectors.com

Main chassis

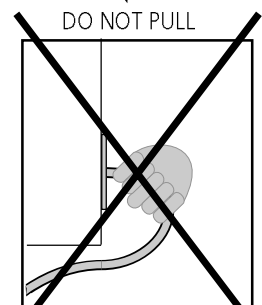
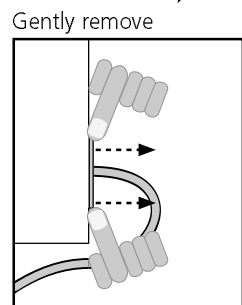
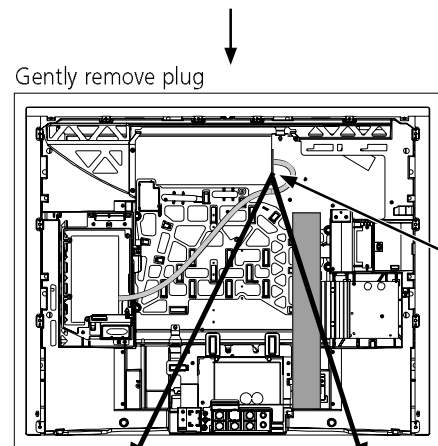
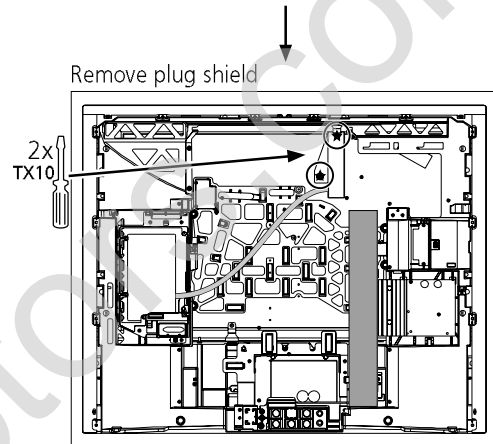
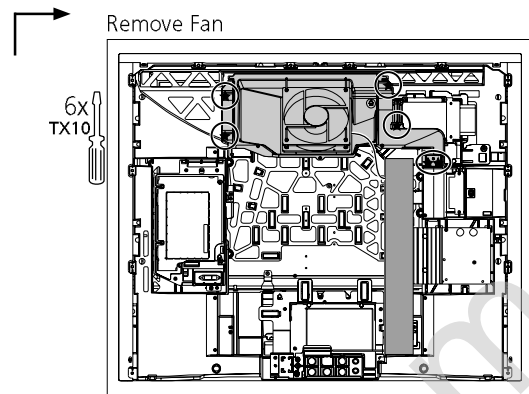
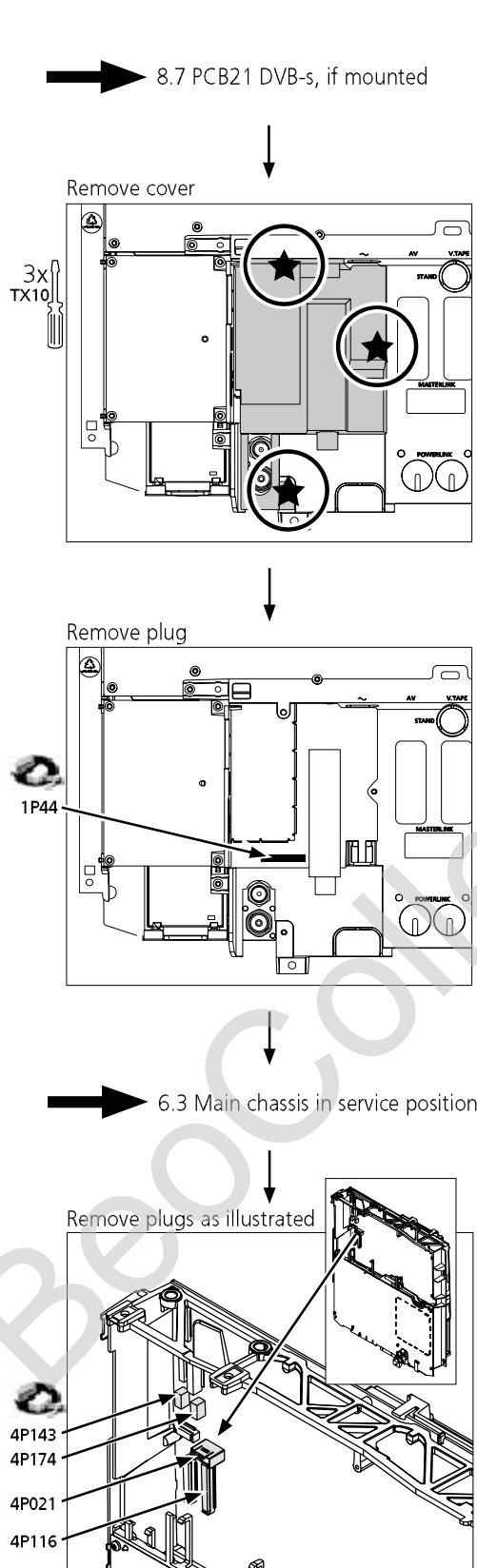

Remove plug

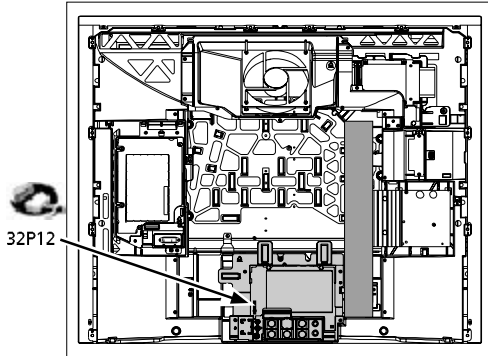

Lift up chassis and remove it with scaler module

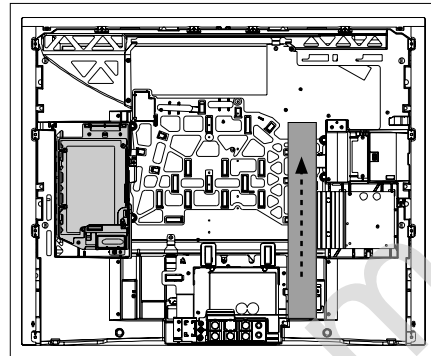

Remove ground wire

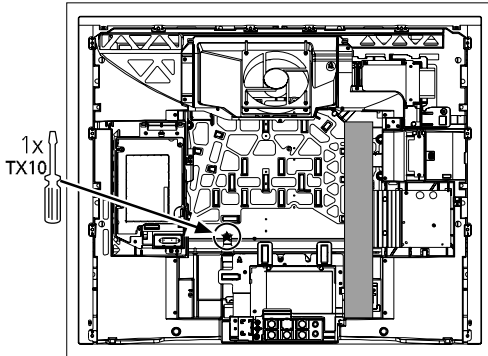

Note: transfer 6IC6

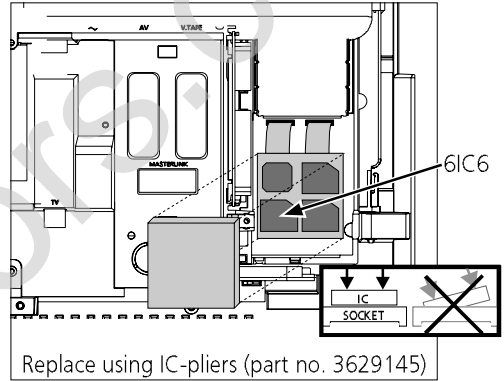

Remove plug

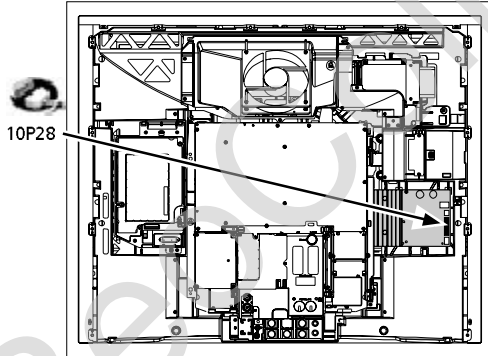

! If DSM module is mounted, transfer the Powerlink module from the new chassis to the old chassis, and mount 2 new covers for the powerlink holes !

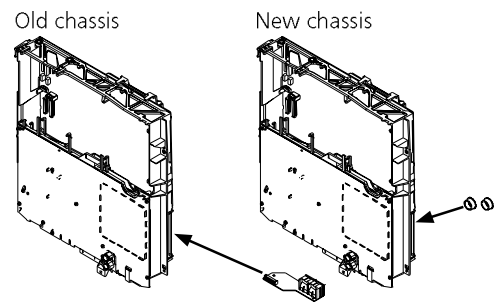

Remove screws for scaler module

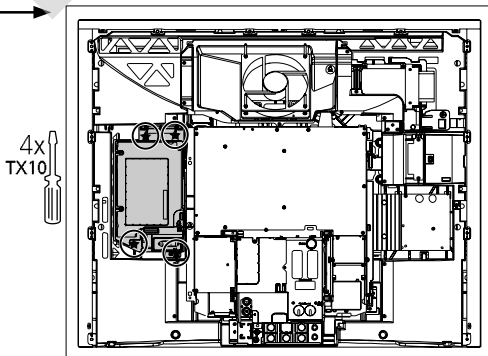

LCD panel

➔ 6.3 Main chassis in service position

➔ 6.4 Remove PCB8, decoupling

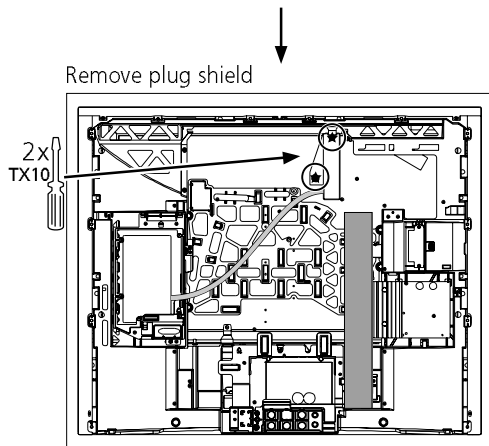
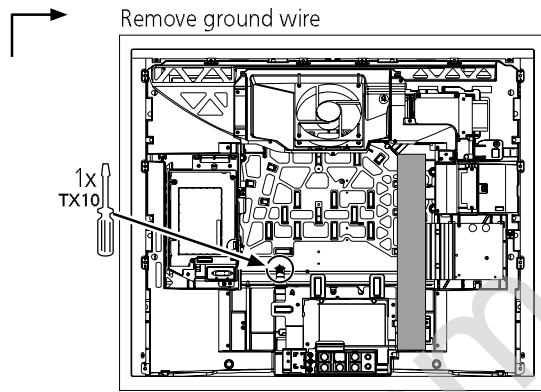

➔ Remove all cables from cableholders

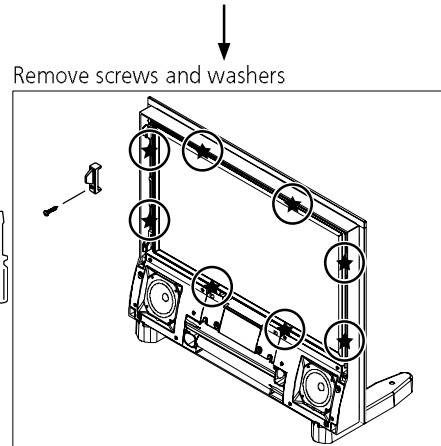
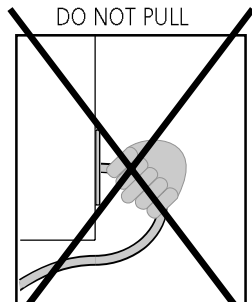
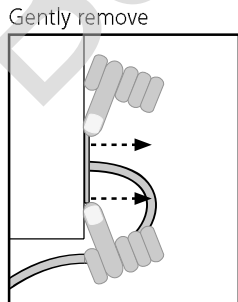
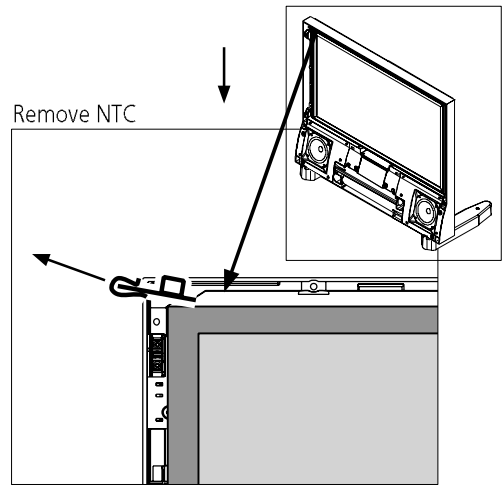
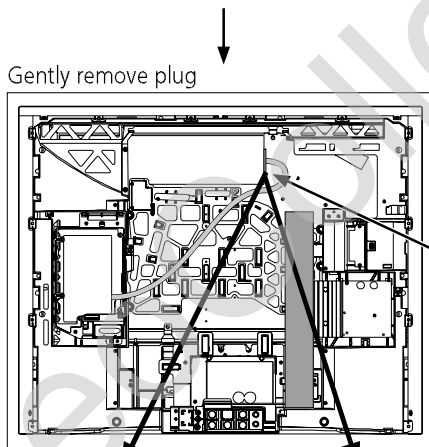

PCB8, Decoupling module

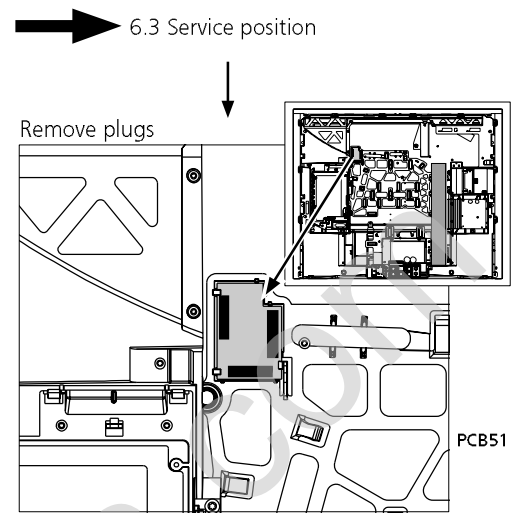

BeoCollectors

PCB10, Sound Output module

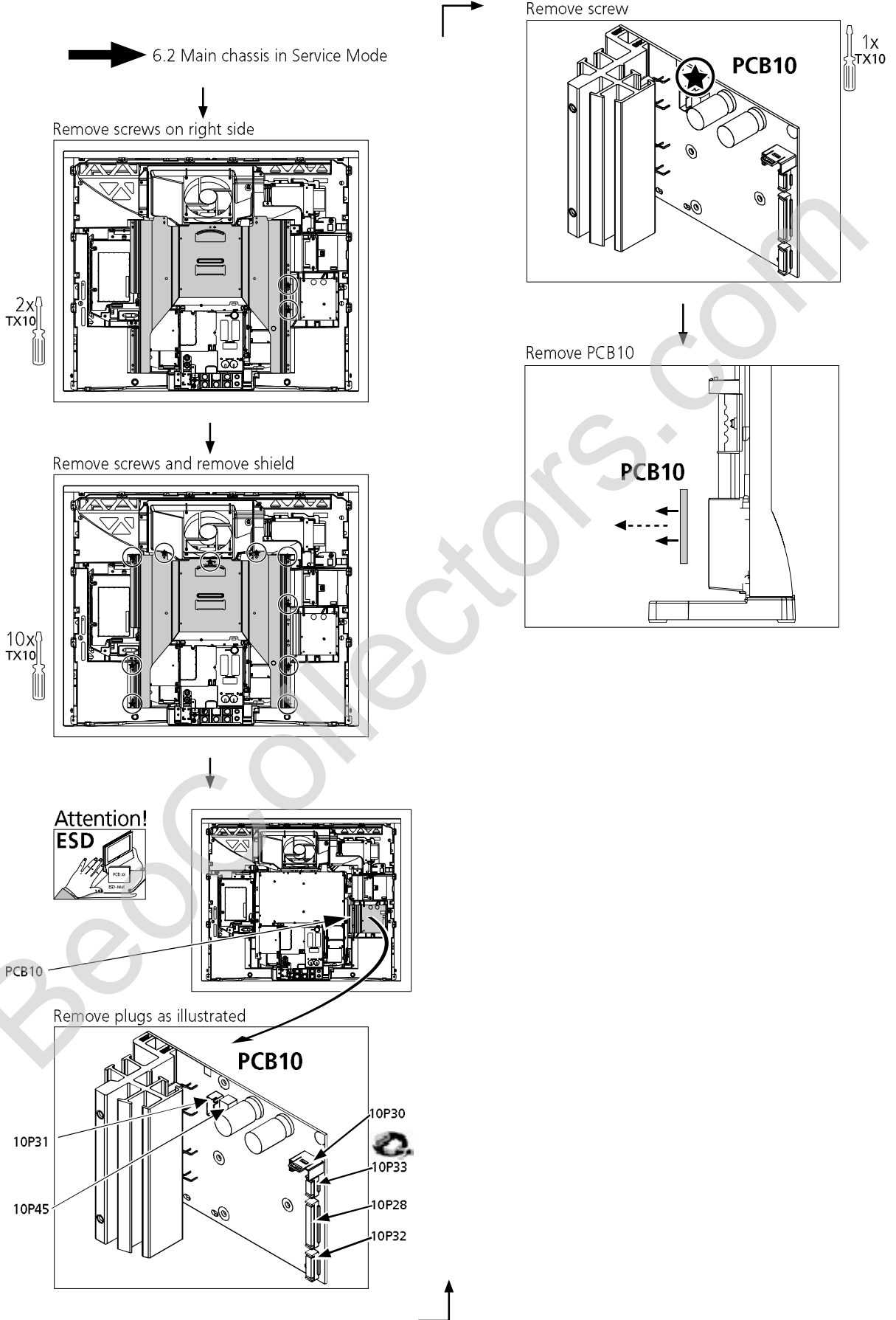

PCB11, IR receiver module

➔ 7.1 Remove speaker cover

➔ 7.1 Remove contrast screen

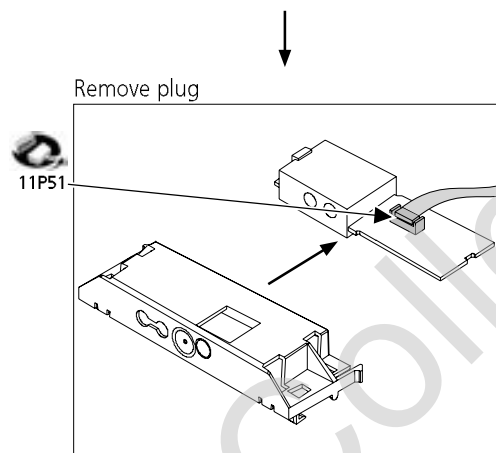
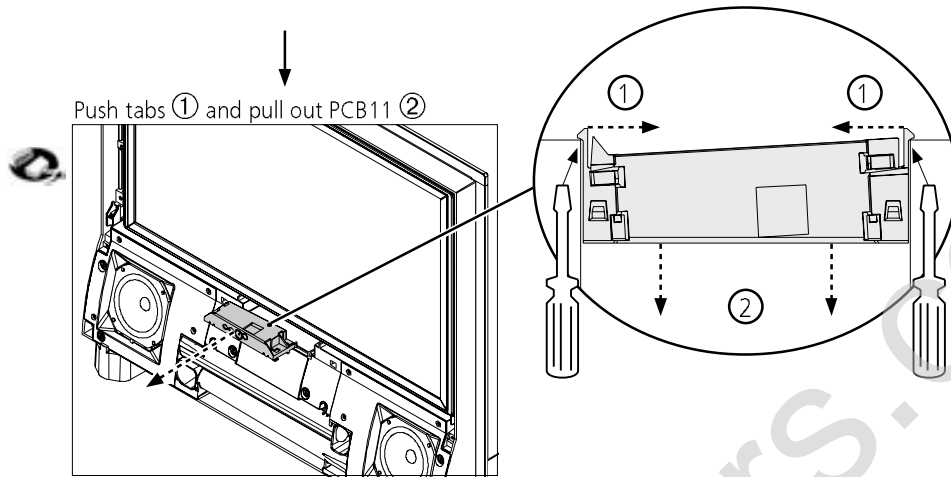

BeoCollectors.com

PCB21, DVB-S module

6.3 Main chassis in service position

Remove cover

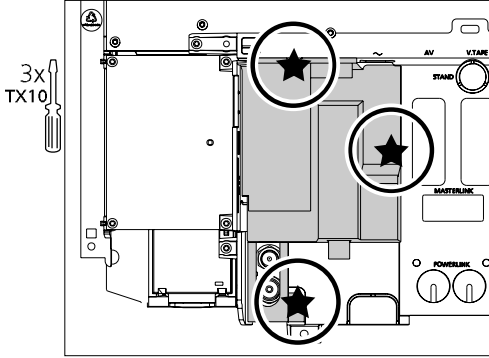

Remove arial cable

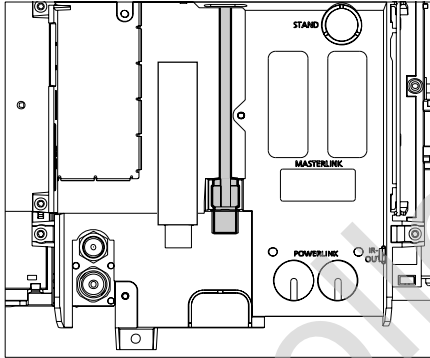

Remove plugs

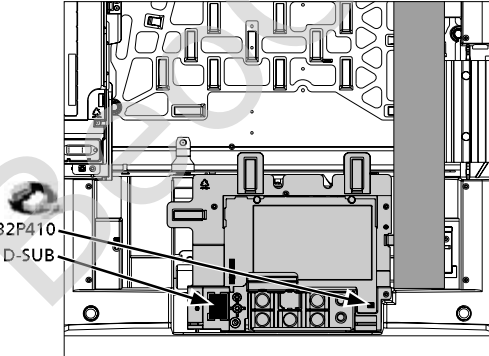

Remove plugs as shown

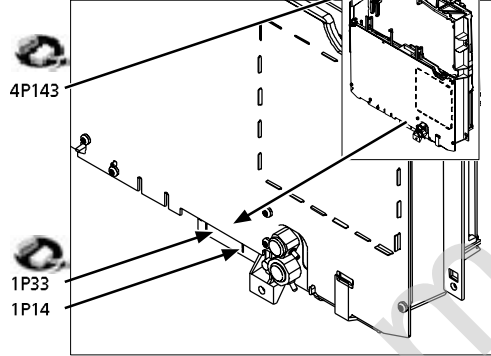

Remove Fan

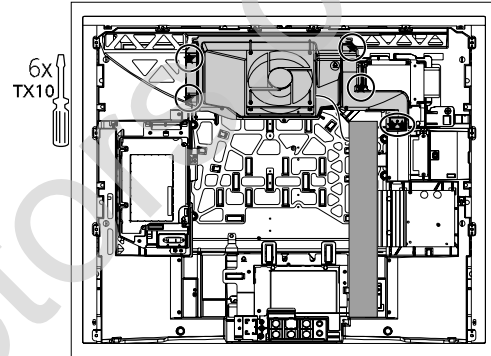

Remove screw

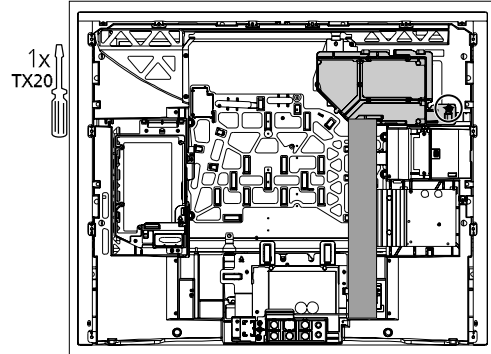

Release snap lock and slide out

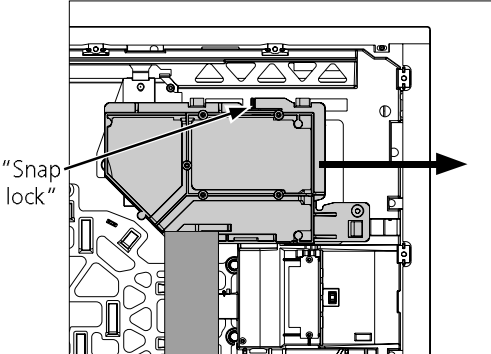

PCB32, DSM module

➔ 6.3 Main chassis in service position



Remove plugs

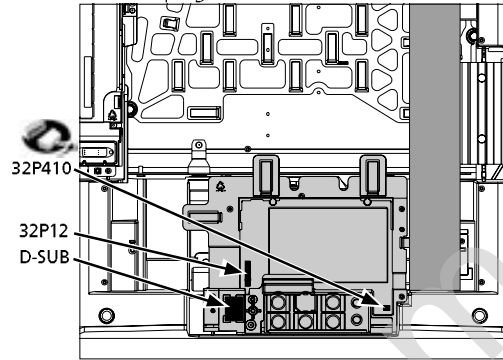

Remove screws

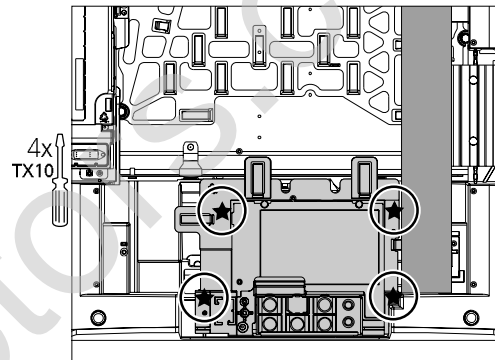

Remove screws on backside

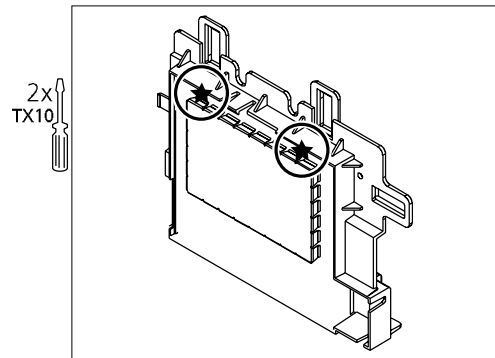

Remove DSM module from holder



BeoCollect

PCB51, Masterlink module

➔ 6.2 Service mode

↓
Placement of PCB51

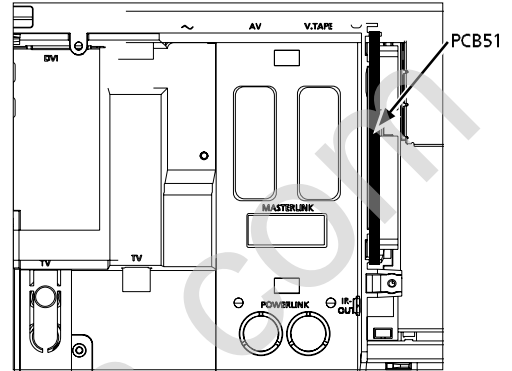

↓
Pull tabs as shown

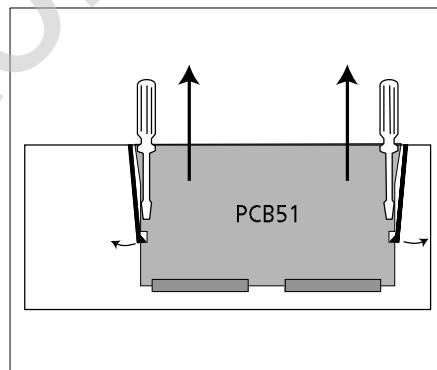

PCB59, Camcorder interface module

➔ 6.2 Service mode

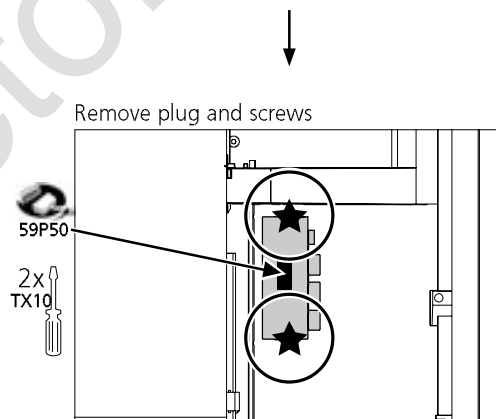
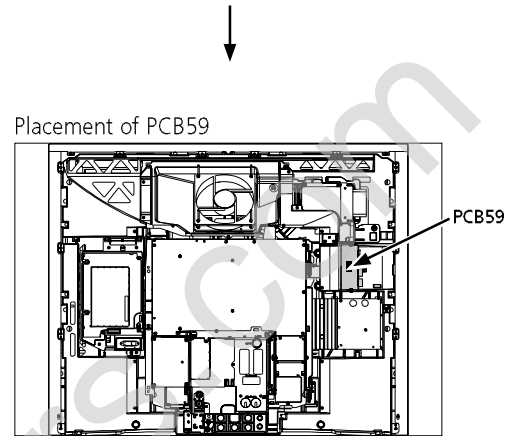

PCB63, Modulator module

➔ 6.3 Main chassis in service position

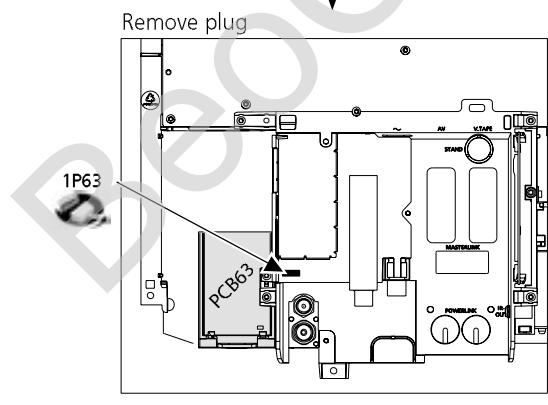
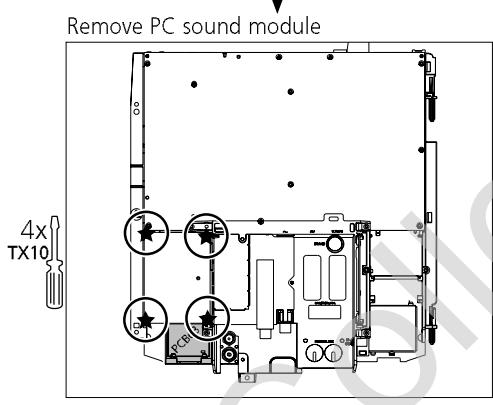
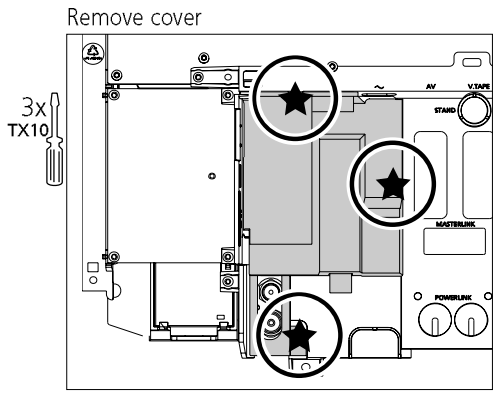

Remove modulator

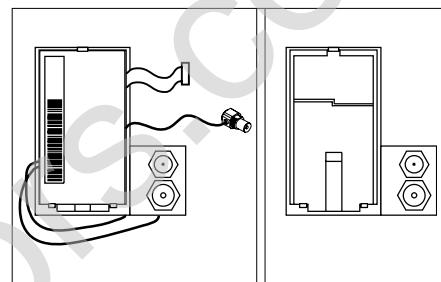
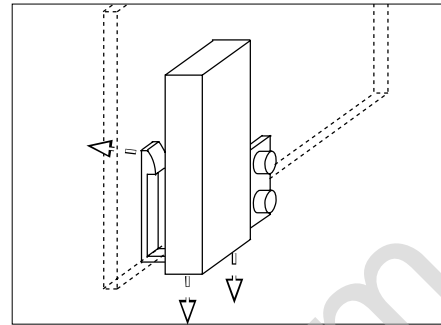

PCB64, Powerlink module

➔ 6.3 Main chassis in service position

↓
Pull tabs as shown

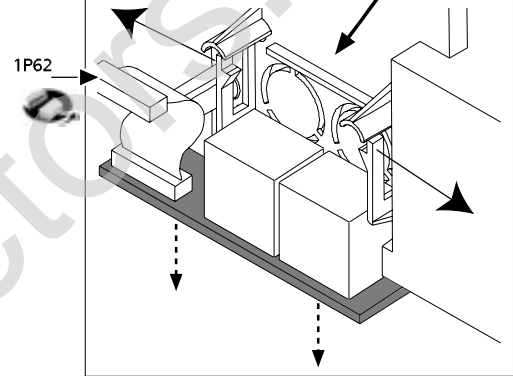
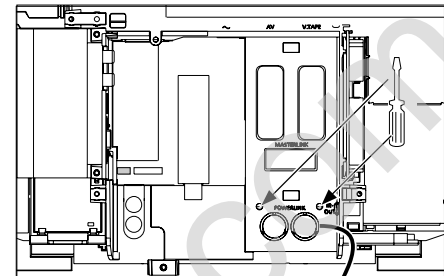

↓
Pull down as shown

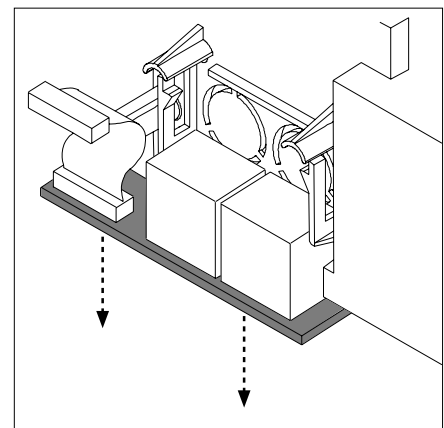

PCB85, Mini jack f. STB-Controller

➔ 6.2 Service mode



Remove PCB85 as shown

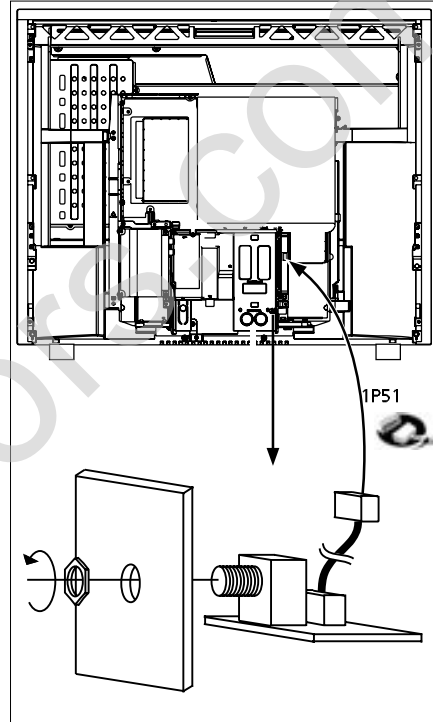

Format 1
15:9

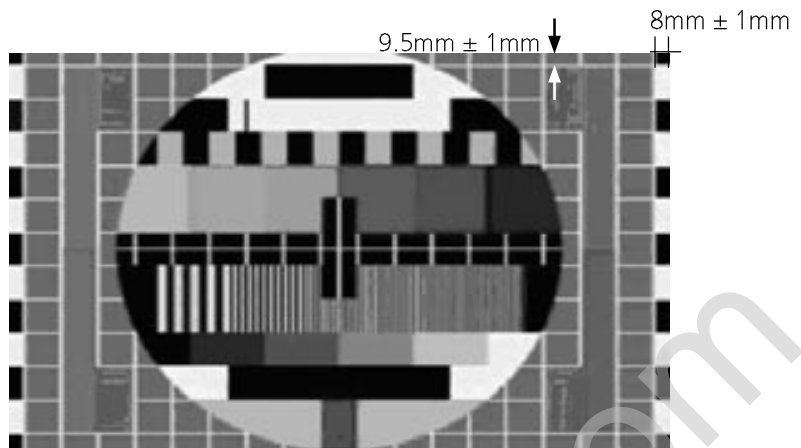

Format 1
4:3

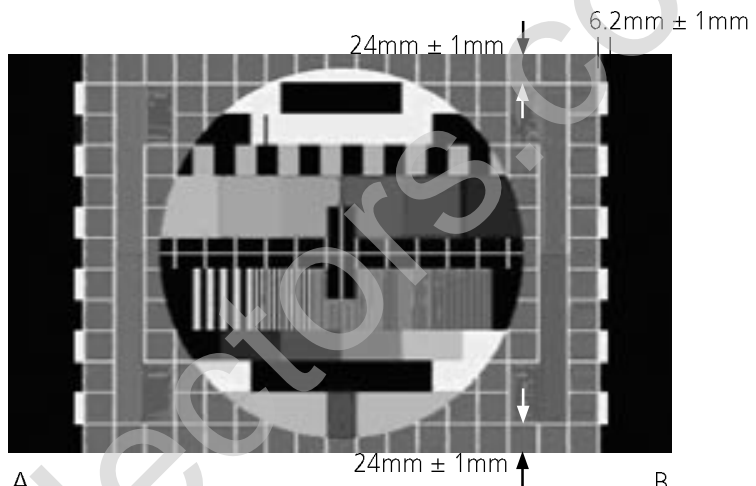

Format 2
Letterbox

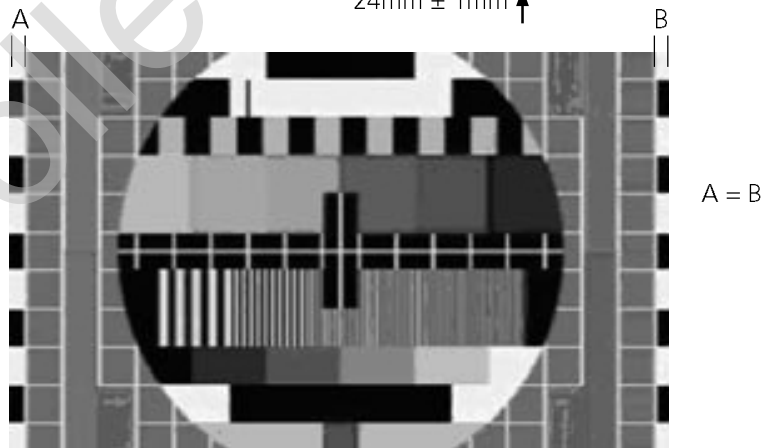

Format 3
16:9

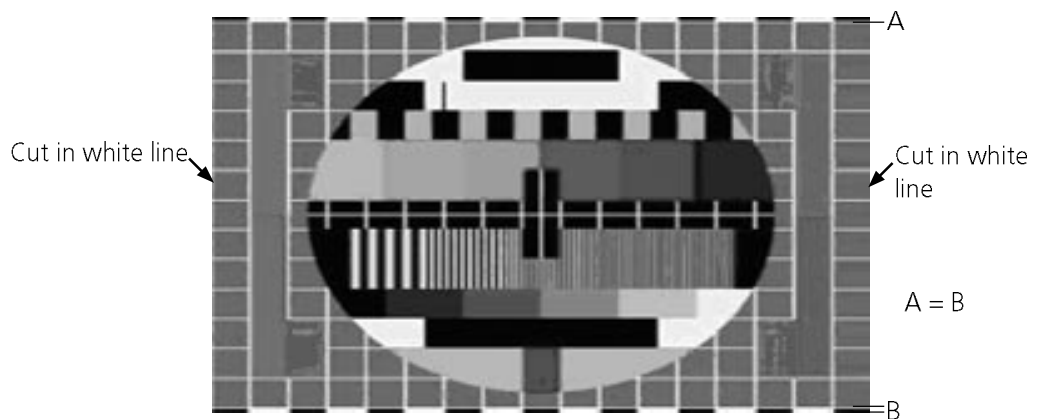

Wiring diagram

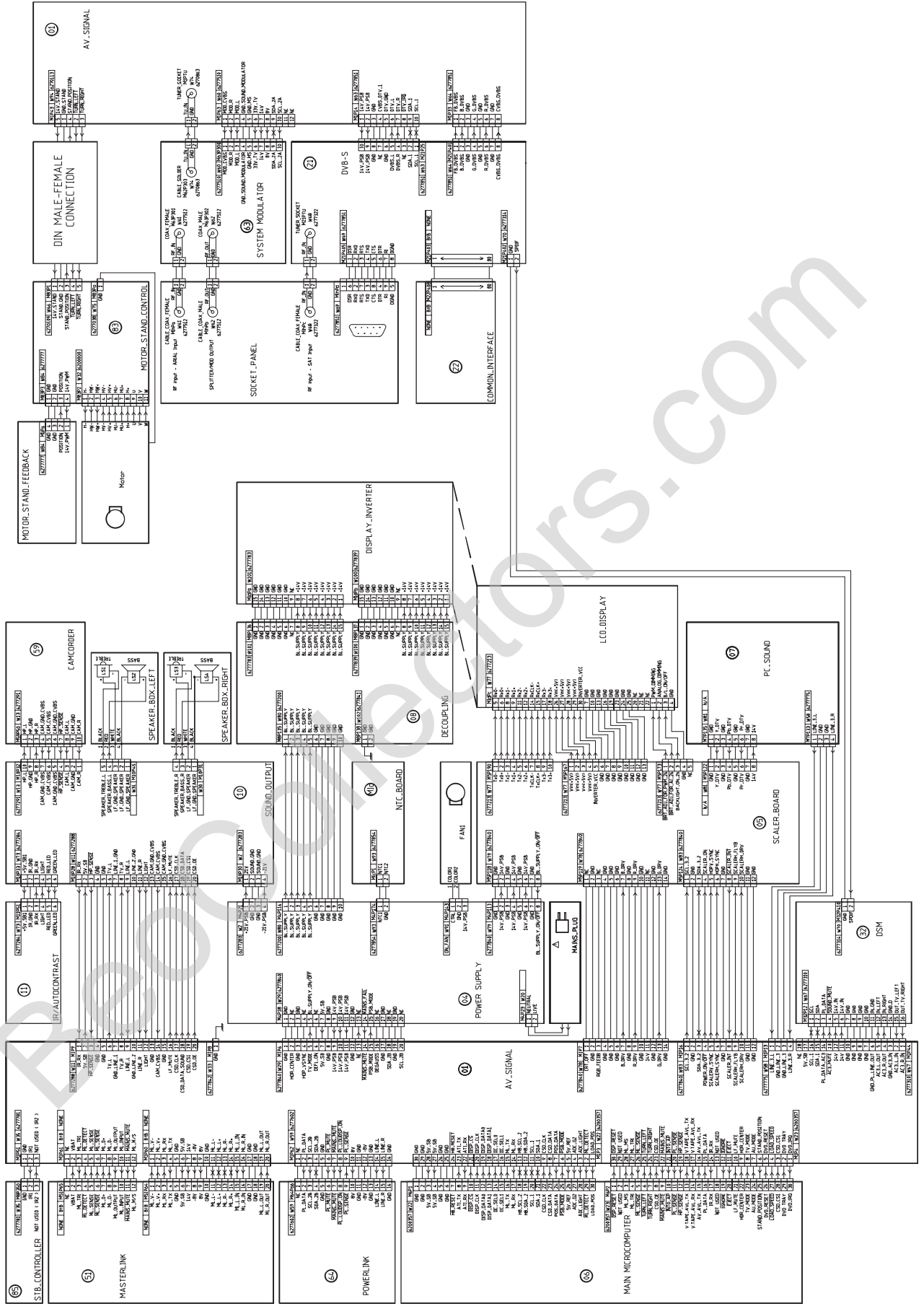

Available parts
BeoVision 6 - 26

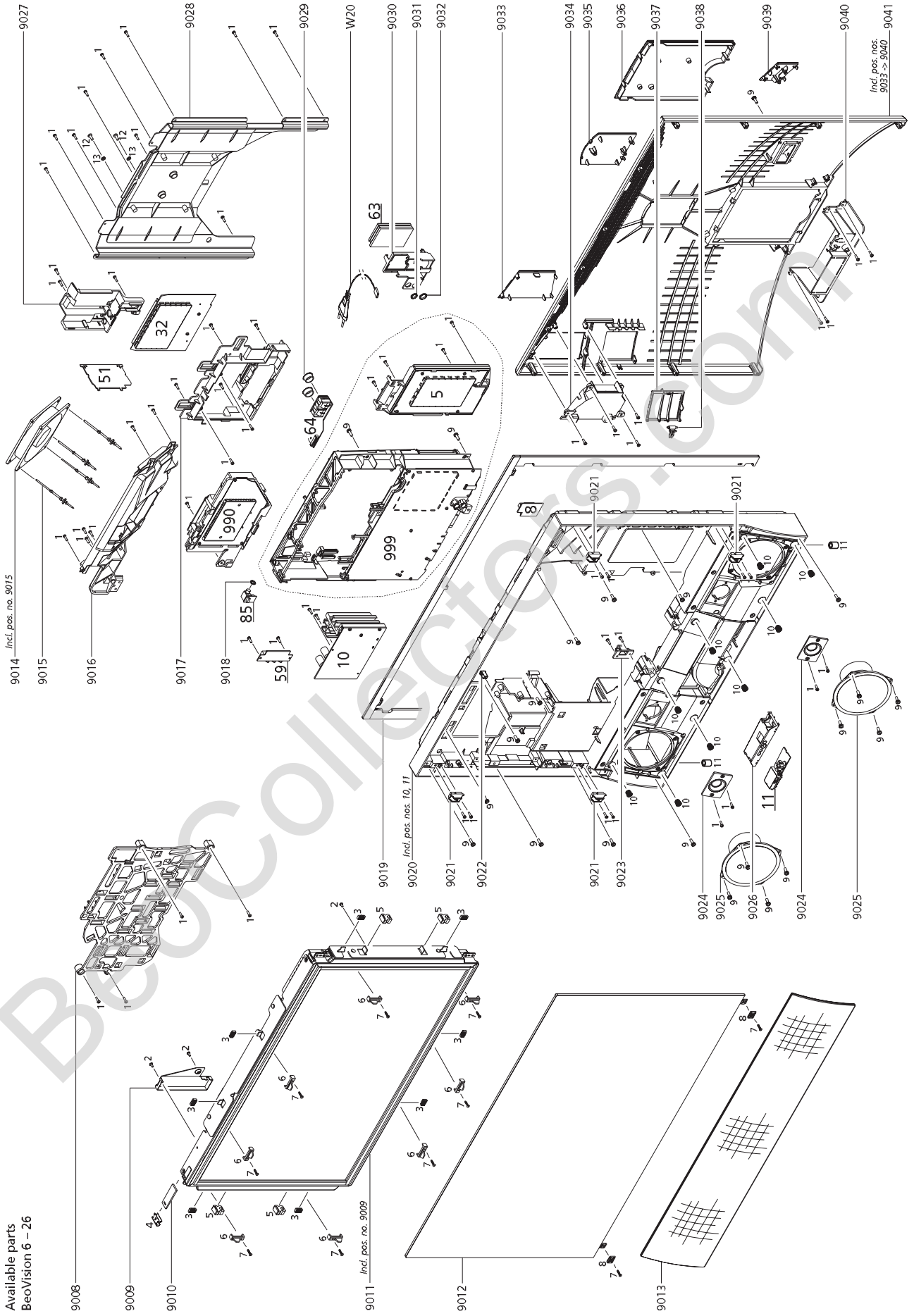

BeoVision 6 – 26

9008	3151338	Cable rack	9025	8480338	Bass
9009	3162045	Shield	9026	3151783	Holder f/PCB11
9010	8001992	NTC PCB	9027	3160091	Cover f/socket panel
9011	8200029	LCD panel, incl. pos. nos. 2, 3, 5, 9009	9028	2576027	Bracket
			9029	3341105	Blind plug
9012	3451376	Contrast screen	9030	3151706	Holder
9013	3320812	Speaker cover	9031	2380170	Nut f/ant. plug
9014	8400018	Fan, incl. pos. no. 9015	9032	2380185	Nut f/female ant. plug
9015	3907001	Rubber bushing	9033	3160333	Cover f/DVB-S
9016	3151232	Holder	9034	3151026	Plate f/DVB-S
9017	3151229	Holder	9035	3160332	Cover f/stand
9018	2380145	Nut	9036	3160330	Cover f/connector panel
9019	3320827	Profile	9037	3160334	Cover f/Camcorder
9020	3320819	Main frame, incl. pos. nos. 10, 11	9038	2810020	Hinge
			9039	3160331	Cover f/DVI
9021	3151766	Bracket	9040	3151822	Cover f/DSM
9022	2810336	Lock	9041	3431473	Back cover, incl. pos. nos. 9033 -> 9040
9023	3151218	Chassis bracket			
9024	8480388	Tweeter			

W20▲	6100325	Mains lead w/filter
	6100404	Mains lead GB
	6100248	Mains lead AUS
	6100037	Mains lead CHN

6Module		PCB6, Main microcomputer
6IC3&6IC4	8344402	SW EPROM
6IC6	8343712	EEPROM

PCB6 Main microcomputer is not available as spare part

8Module	8001990	PCB8, Decoupling
---------	---------	------------------

10Module	8001991	PCB10, Sound Out
----------	---------	------------------

11Module	8000885	PCB11, IR
----------	---------	-----------

32Module	8000910	PCB32, DSM
32IC607	8344177	Software
	3151572	Holder f/sockets

51Module	8000882	PCB51, Masterlink
----------	---------	-------------------

59Module	8001996	PCB59, Camcorder
----------	---------	------------------

63Module	8000521	PCB63, Modulator system G
	8000522	PCB63, Modulator system I

64Module	8000921	PCB64, Powerlink
----------	---------	------------------

85Module	8008922	PCB85, Minijack
----------	---------	-----------------

990Module	8053041	DVB-S chassis
-----------	---------	---------------

999Module		Main chassis consist of PCB1, PCB4, PCB5, PCB6, PCB7, PCB51, PCB63, PCB64, PCB85
	8053050	Main chassis, system BG w/G modulator
	8053051	Main chassis, system BGMIDK w/G modulator
	8053052	Main chassis, system BGMIDK w/I modulator
	8053053	Main chassis, system BGLL'IDK w/G modulator
	8053054	Main chassis, system BGLL'IDK w/G modulator

Survey of screws, washers etc.

1	2013137	Screw 3 x 10mm	8	3031064	Washer
2	2039027	Screw 3 x 6mm	9	2019021	Screw 4 x 12mm
3	3907004	Rubber bushing	10	2930178	Bushing
4	2816113	Spring	11	2934162	Insert
5	3907005	Damper	12	2034004	Screw 4 x 10mm
6	3031074	Bracket	13	2625003	Washer
7	2015182	Screw 3 x 13mm			

▲ symbol of safety component

Wire bundles

See wiring diagram page 10.1.

The part no. is printed on the diagram above the wire bundle, as shown.

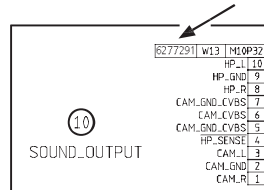
**Parts not shown**

3375079	Product cover
3375038	Service stand
3395247	Back-up suitcase, system BG w/G modulator
3395248	Back-up suitcase, system BGMIDK w/G modulator
3395249	Back-up suitcase, system BGMIDK w/I modulator
3395250	Back-up suitcase, system BGLL'IDK w/G modulator
3395251	Back-up suitcase, system BGLL'IDK w/I modulator

ServiceTool

3658964	ServiceTool CD-ROM
3375397	Cable kit for ServiceTool, complete
Cable kit consists of:	
6270857	Main cable
6270852	Cable D-SUB-Jack
6277439	Wire, 3 pole
8008922	Minijack f/STB-Controller

Accessories

See specification guidelines page 9.2

Available documentation

Guides and Reference books, please see Retail Ordering System

Packing

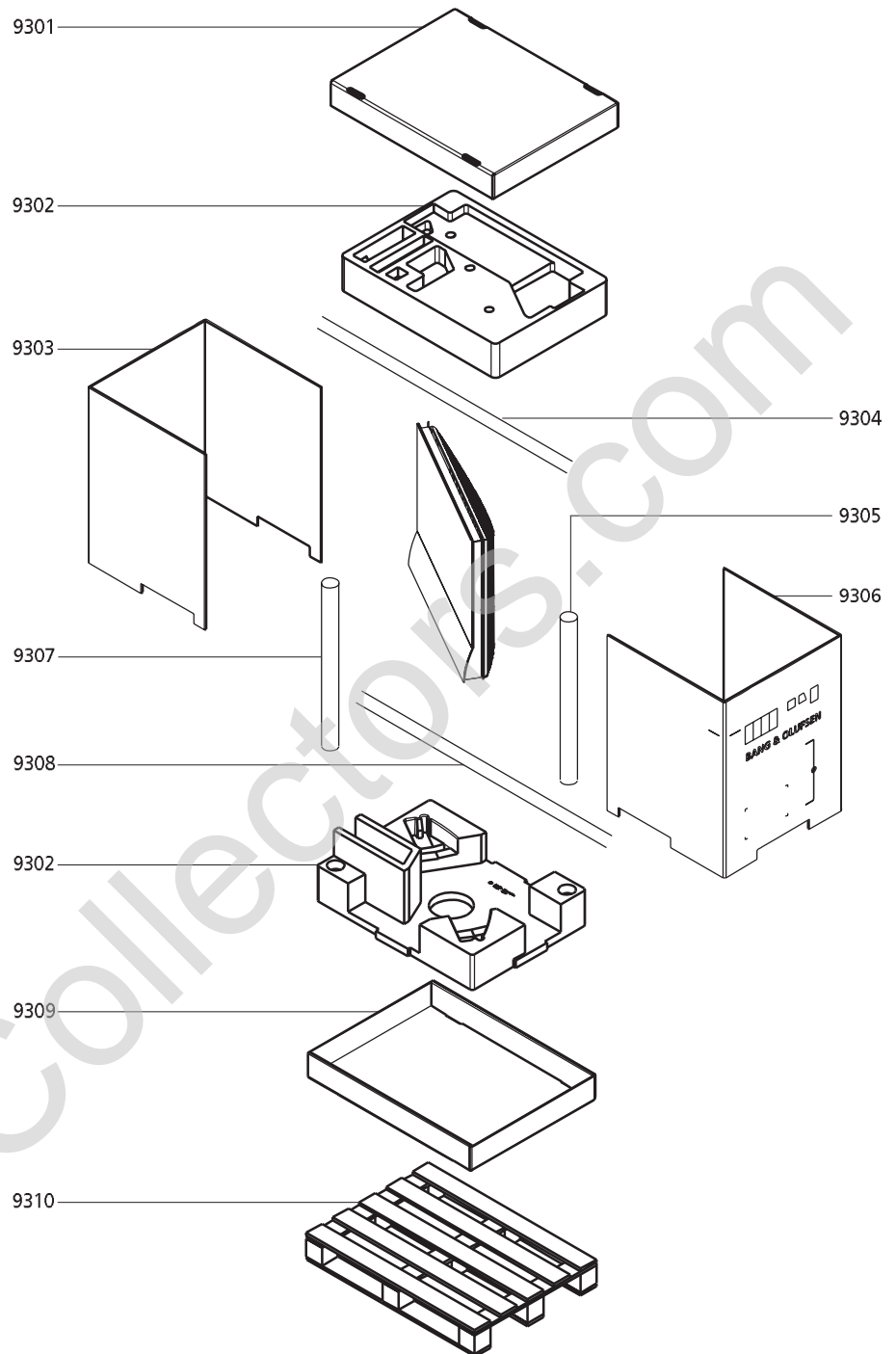

9301	3392766	Outer carton, top
9302	3396262	Foam packing, set of top and bottom
9303	3392155	Outer carton
9304	3917105	Foam foil
9305	3392200	Distance pipe
9306	3392155	Outer carton
9307	3392200	Distance pipe
9308	3917105	Foam foil
9309	3392766	Outer carton, bottom
9310	3392685	Wooden pallet
	3392768	Wooden pallet, heat treated
	3375424	Tip and tell

Base 4090

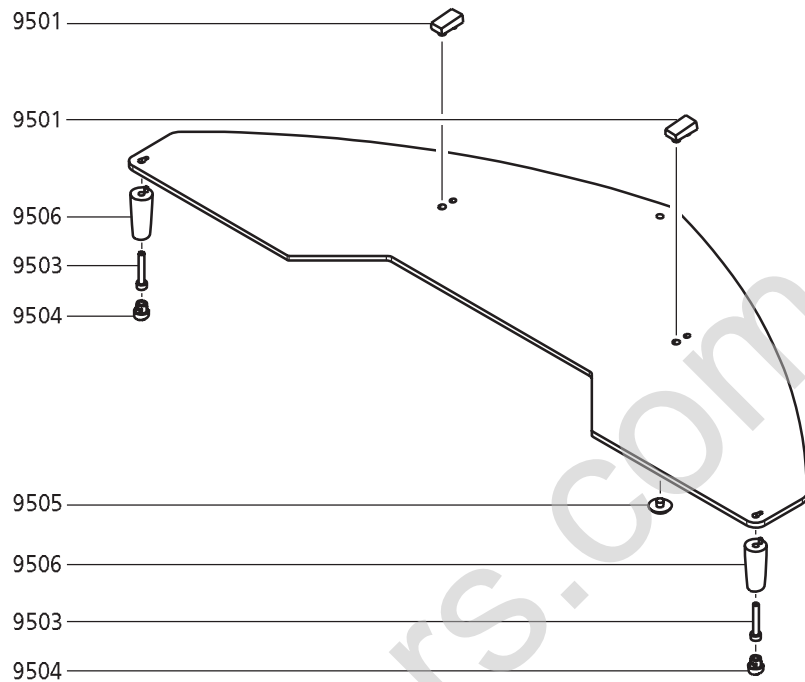

9501	2576361	Spacer
9503	2058069	Screw 4 x 25mm
9504	3103414	Cover f/screw
9505	3103418	Foot
9506	3103101	Alu. foot
	3390664	Cable cover
	3504730	Guide
	3392400	Packing, complete

Floor stand 4091

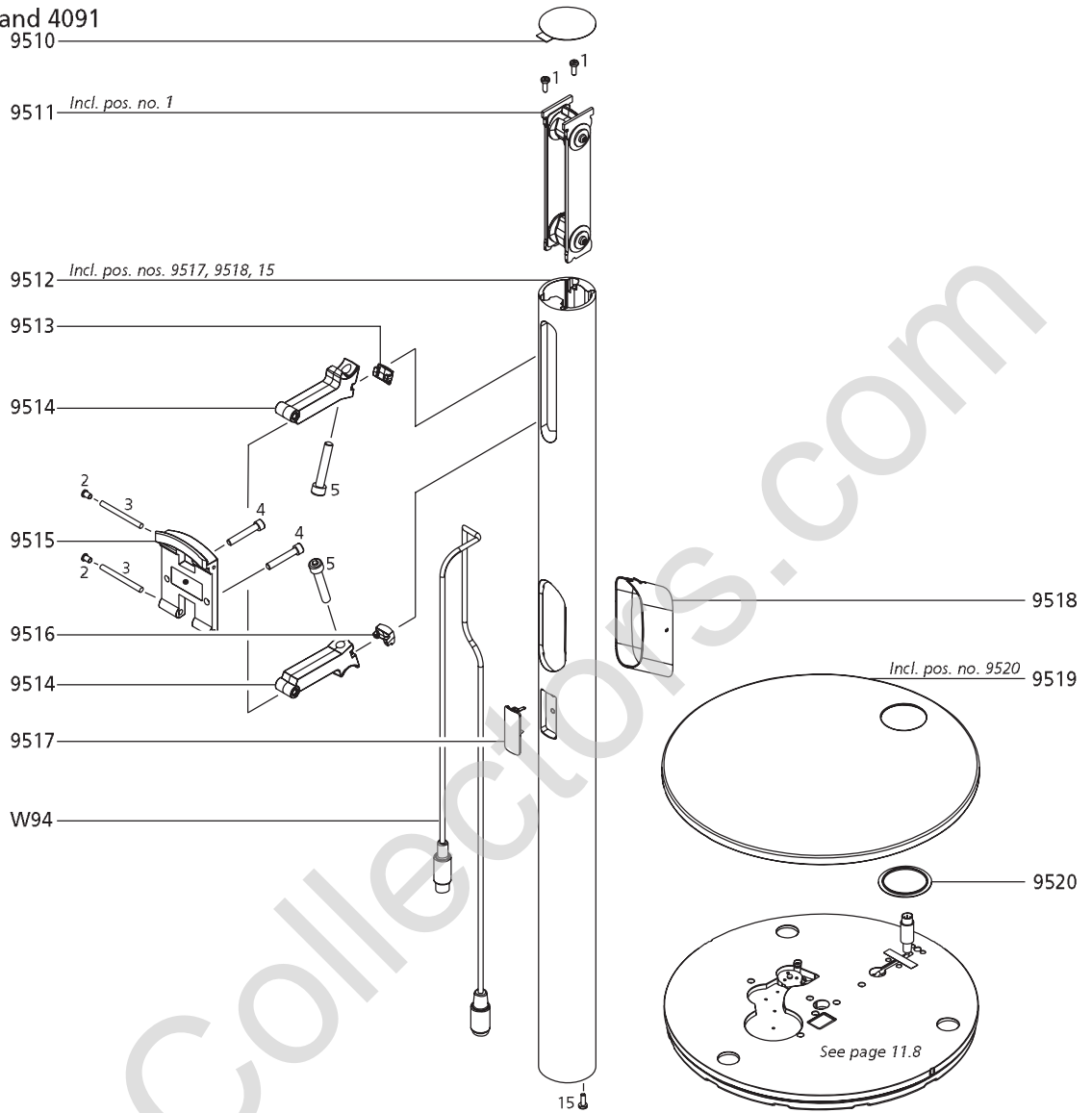

9510	3459468	Plate	9515	3151142	Bracket
9511	3130349	Tilt mechanism, incl. pos. no. 1	9516	3010057	Stopper, white
9512	2950115	Aluminium tube, incl. pos. nos. 9517, 9518, 15	9517	2950111	Cover
9513	3010058	Stopper, black	9518	2950050	Conduit
9514	3151416	Arm	9519	3459470	Cover plate incl. pos. no. 9520
			9520	2576017	Scratch shield
W94	6270113	Extension cable 5pole DIN male-female			
1	2015001	Screw 4 x 12mm	4	2058077	Screw 5 x 20mm
2	3341008	Plug	5	2058076	Screw 8 x 45mm
3	2830030	Needle	15	2015001	Screw 4 x 12mm
	3390012	Set of accessories			
	3504771	Guide			
	3396254	Foam - order 2 pcs.			
	3392052	Outer carton			
	2777038	Handle			
	2777037	Handle, plate			

Table stand 4092

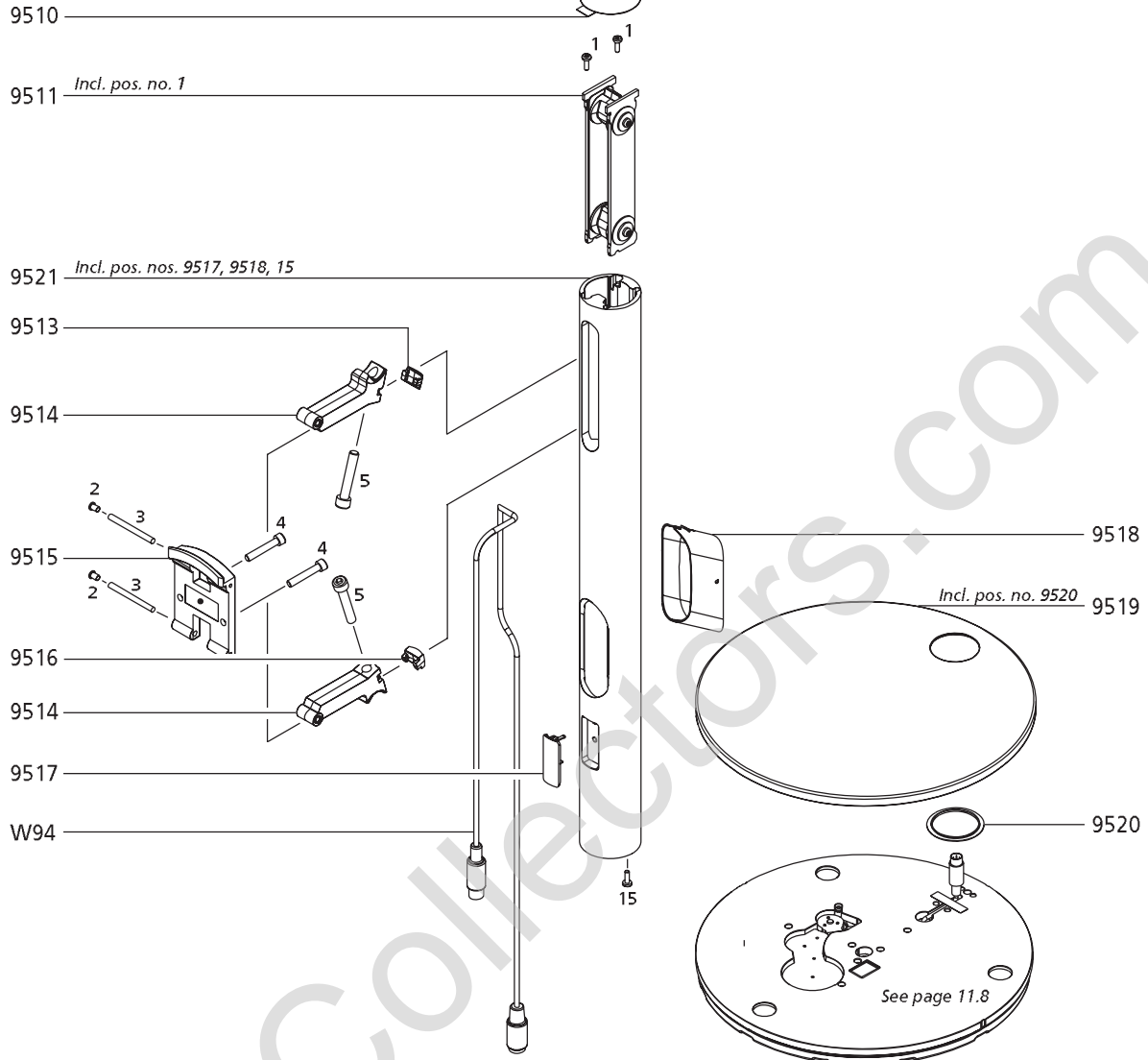

9510	3459468	Plate	9517	2950111	Cover
9511	3130349	Tilt mechanism, incl. pos. no 1	9518	2950050	Conduit
9513	3010058	Stopper, black	9519	3459470	Cover plate incl. pos. no. 9520
9514	3151416	Arm	9520	2576017	Scratch shield
9515	3151142	Bracket	9521	2950116	Aluminium tube, incl. pos. nos. 9517, 9518,
9516	3010057	Stopper, white			

W94 6270113 Extension cable 5pole DIN male-female

1	2015001	Screw 4 x 12mm	4	2058077	Screw 5 x 20 mm
2	3341008	Plug	5	2058076	Screw 8 x 45mm
3	2830030	Needle	15	2015001	Screw 4 x 12mm

3390011 Set of accessories

3504771 Guide

3396253 Foam - order 2 pcs.

3392050 Outer carton

2777038 Handle

2777037 Handle, plate

Turnable unit

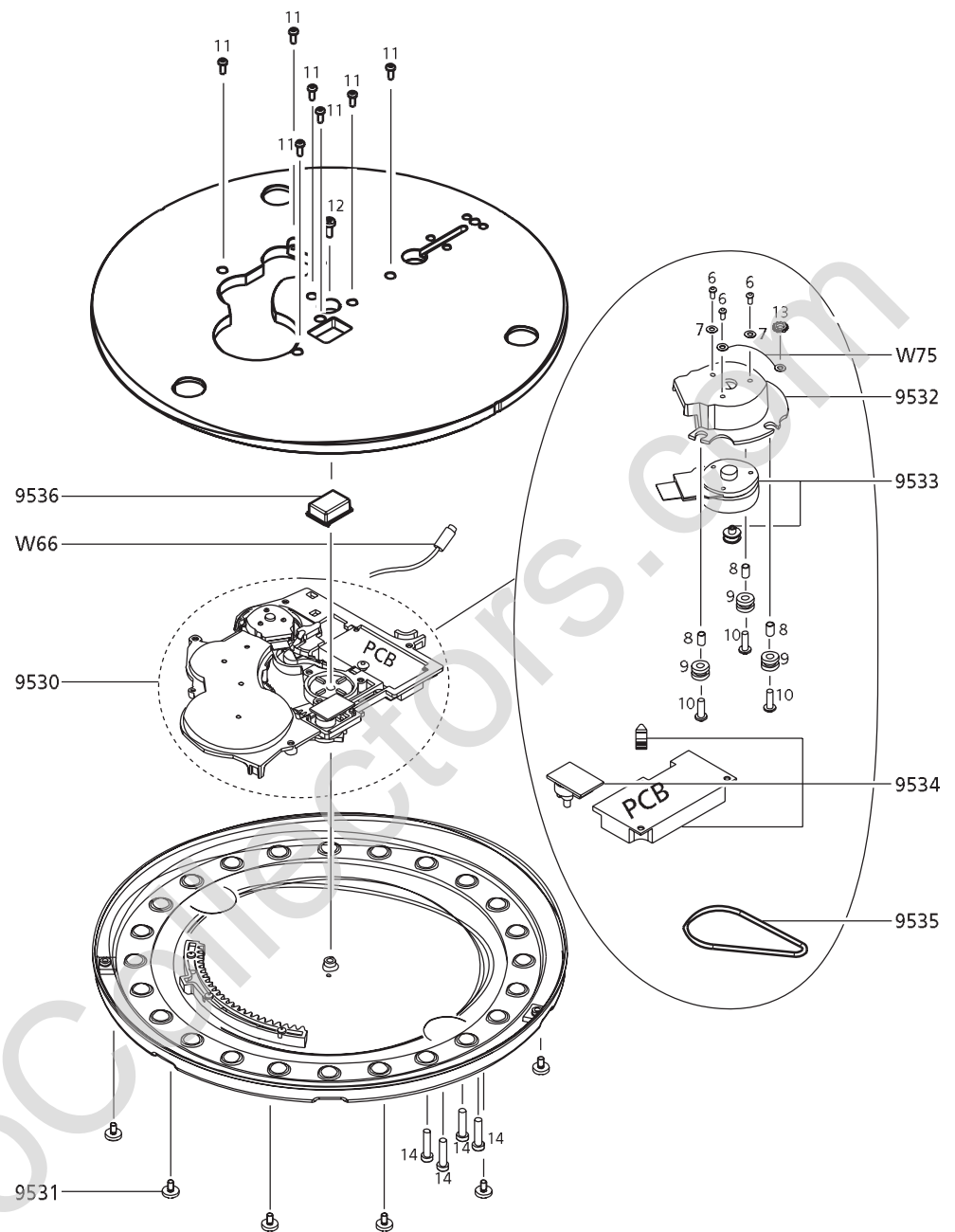

9530	2755011	Gear, complete	9534	8052028	PCB f/motor
9531	3390662	Bag w/6 x foot	9535	2732156	Belt
9532	3114003	Cover f/motor	9536	3114496	House
9533	8400004	Motor			

W66	6270109	Wire DIN 5 pole
W75	6277038	Ground wire

6	2033001	Screw 7 x 3.5mm
7	2622110	Washer
8	2930074	Bushing
9	2938306	Rubber bushing
10	2013156	Screw 2.5 x 8mm
11	2019020	Screw 4 x 10mm
12	2058074	Screw 5 x 12mm
13	2526003	Washer
14	2058079	Screw 6 x 25mm

Wall Bracket 4093

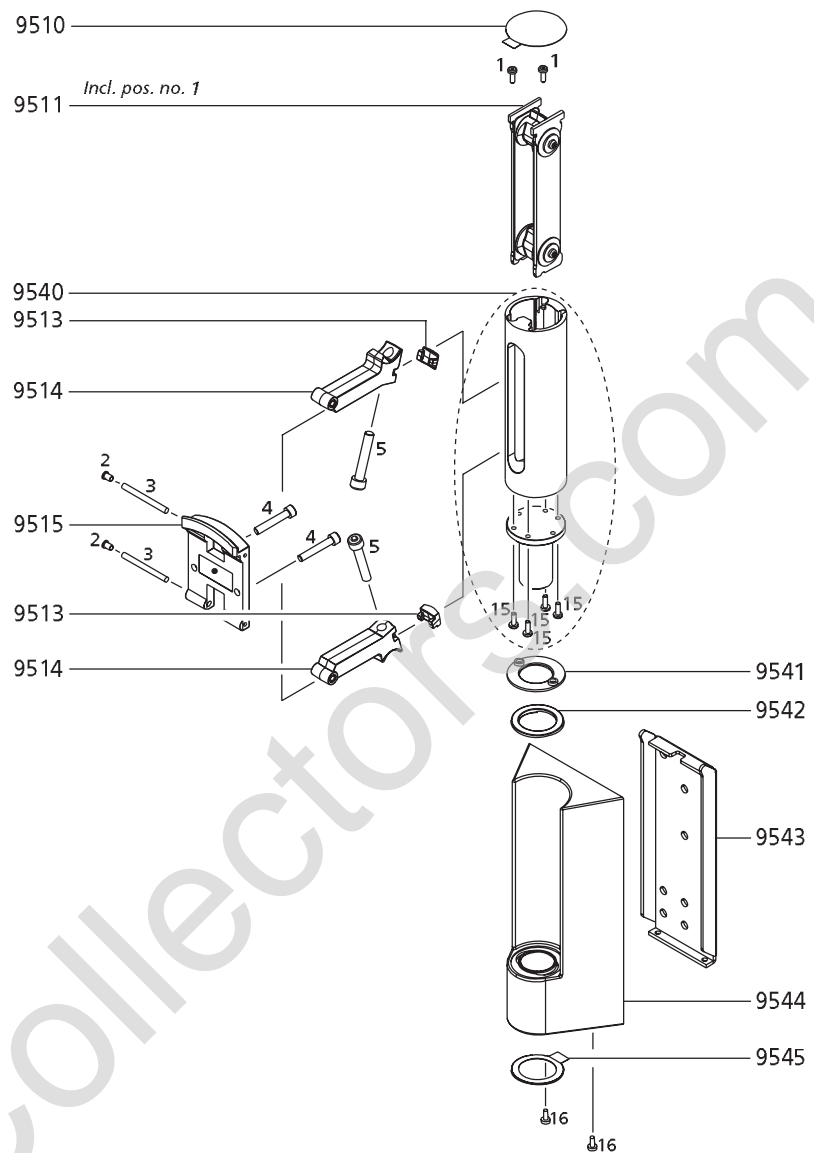

9510	3459468	Plate		
9511	3130349	Tilt mechanism, incl. pos. no. 1		
9513	3010058	Stopper, black		
9514	3151416	Arm		
9515	3151142	Bracket		
9540	2950119	Alu. tube		
9541	2620004	Friction disc, upper		
9542	2620003	Friction disc, lower		
9543	3031021	Mounting bracket		
9544	3151819	Wall bracket		
9545	3452035	Plate		

1	2015001	Screw 4 x 12mm	5	2058076	Screw 8 x 45mm
2	3341008	Plug	15	2015001	Screw 4 x 12mm
3	2830030	Needle	16	2043016	Screw 4 x 10mm
4	3390012	Screw f/TV			

3390010	Bag w/2 x screws f/TV, cable cover, hexagon spanner
3504775	Guide
3396256	Foam packing - order 2 pcs.
3392054	Outer carton

BeoCollectors.com

BeoCollectors.com

Bang & Olufsen
DK-7600 Struer
Denmark

Phone +45 96 84 11 22*
Fax +45 97 85 39 11

3538011 09-04