

# Service Manual

Blu-ray Disc Recorder

Model No. **DMR-UBS80EG**  
**DMR-UBS90EG**

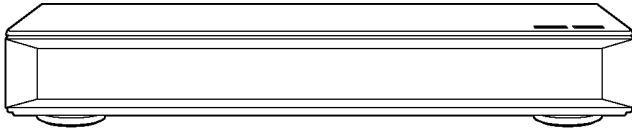

The illustration shows the image of DMR-UBS90EG.

**Notes:** These model's BD Drive is TXP0012.





When replacing HDD, Main P.C.B. or EEPROM, "HDD Error" indication is displayed and HDD must be formatted.

After that, programme in the HDD will be lost.

In detail, please refer to Service Navigation in this Service Manual.

Colour

(K) ..... Black Type

<p>"AVCHD", "AVCHD 3D", "AVCHD Progressive" and "AVCHD 3D/Progressive" are trademarks of Panasonic Corporation and Sony Corporation.</p>
<p>Copyright 2004-2014 Verance Corporation. Cinavia™ is a Verance Corporation trademark. Protected by U.S. Patent 7,369,677 and worldwide patents issued and pending under license from Verance Corporation. All rights reserved.</p>
<p>DLNA, the DLNA Logo and DLNA CERTIFIED are trademarks, service marks, or certification marks of the Digital Living Network Alliance.</p>
<p>DVB and the DVB logos are trademarks of the DVB Project.</p>
<p>DiSEqC™ is a trademark of EUTELSAT.</p>
<p>The "CI Plus" Logo is a trademark of CI Plus LLP.</p>
<p>Dolby, Dolby Audio, and the double-D symbol are trademarks of Dolby Laboratories.</p>
<div style="text-align: right;">  </div>
<p>For DTS patents, see <a href="http://patents.dts.com">http://patents.dts.com</a>.  Manufactured under license from DTS Licensing Limited. DTS, DTS-HD, the Symbol, &amp; DTS and the Symbol together are registered trademarks, and DTS-HD Master Audio   Essential is a trademark of DTS, Inc.  © DTS, Inc. All Rights Reserved.</p>
<div style="text-align: right;">  </div>
<p>"DVD Logo" is a trademark of DVD Format/Logo Licensing Corporation.</p>
<p>MPEG Layer-3 audio coding technology licensed from Fraunhofer IIS and Thomson.</p>
<p>This product is licensed under the AVC patent portfolio license for the personal use of a consumer or other uses in which it does not receive remuneration to (i) encode video in compliance with the AVC Standard ("AVC Video") and/or (ii) decode AVC Video that was encoded by a consumer engaged in a personal activity and/or was obtained from a video provider licensed to provide AVC Video.  No license is granted or shall be implied for any other use.  Additional information may be obtained from MPEG LA, L.L.C.  See <a href="http://www.mpegla.com">http://www.mpegla.com</a></p>
<p>This product is licensed under the VC-1 patent portfolio license for the personal and non-commercial use of a consumer to (i) encode video in compliance with the VC-1 Standard ("VC-1 Video") and/or (ii) decode VC-1 Video that was encoded by a consumer engaged in a personal and non-commercial activity and/or was obtained from a video provider licensed to provide VC-1 video.  No license is granted or shall be implied for any other use. Additional information may be obtained from MPEG LA, L.L.C.  See <a href="http://www.mpegla.com">http://www.mpegla.com</a></p>
<p>SDXC Logo is a trademark of SD-3C, LLC.</p>
<p>The Wi-Fi CERTIFIED™ Logo is a certification mark of Wi-Fi Alliance®.  The Wi-Fi Protected Setup™ Logo is a certification mark of Wi-Fi Alliance®.</p>
<div style="text-align: right;">  </div>
<p>"Wi-Fi®", "Miracast®", and "Wi-Fi Direct®" are registered trademarks of Wi-Fi Alliance®.  "Wi-Fi Protected Setup™", "WPA™", and "WPA2™" are trademarks of Wi-Fi Alliance®.</p>
<p>The terms HDMI and HDMI High-Definition Multimedia Interface, and the HDMI Logo are trademarks or registered trademarks of HDMI Licensing, LLC in the United States and other countries.</p>
<p>Java is a registered trademark of Oracle and/or its affiliates.</p>
<div style="text-align: right;">  </div>
<p>Windows is a trademark or a registered trademark of Microsoft Corporation in the United States and other countries.</p>
<p>Android is a trademark of Google Inc.</p>

<p>This product incorporates the following software:</p> <p>(1) the software developed independently by or for Panasonic Corporation,  (2) the software owned by third party and licensed to Panasonic Corporation,  (3) the software licensed under the GNU General Public License, Version 2.0 (GPL V2.0),  (4) the software licensed under the GNU LESSER General Public License, Version 2.1 (LGPL V2.1), and/or  (5) open source software other than the software licensed under the GPL V2.0 and/or LGPL V2.1.</p> <p>The software categorized as (3) - (5) are distributed in the hope that it will be useful, but WITHOUT ANY WARRANTY, without even the implied warranty of MERCHANTABILITY or FITNESS FOR A PARTICULAR PURPOSE. Please refer to the detailed terms and conditions thereof shown in the Basic Settings menu.</p> <p>At least three (3) years from delivery of this product, Panasonic will give to any third party who contacts us at the contact information provided below, for a charge no more than our cost of physically performing source code distribution, a complete machine-readable copy of the corresponding source code covered under GPL V2.0, LGPL V2.1 or the other licenses with the obligation to do so, as well as the respective copyright notice thereof.  Contact Information: oss-cd-request@gg.jp.panasonic.com</p> <p>The source code and the copyright notice are also available for free in our website below.  <a href="http://panasonic.net/avc/oss/">http://panasonic.net/avc/oss/</a></p>
<p><b>MS/PlayReady/Final Product Labeling</b></p> <p>This product contains technology subject to certain intellectual property rights of Microsoft. Use or distribution of this technology outside of this product is prohibited without the appropriate license(s) from Microsoft.</p>
<p><b>MS/PlayReady/End User Notices</b></p> <p>Content owners use Microsoft PlayReady™ content access technology to protect their intellectual property, including copyrighted content. This device uses PlayReady technology to access PlayReady-protected content and/or WMDRM-protected content. If the device fails to properly enforce restrictions on content usage, content owners may require Microsoft to revoke the device's ability to consume PlayReady-protected content.</p> <p>Revocation should not affect unprotected content or content protected by other content access technologies. Content owners may require you to upgrade PlayReady to access their content. If you decline an upgrade, you will not be able to access content that requires the upgrade.</p>
<p><b>Vorbis, FLAC, WPA Supplicant</b></p> <p>The software licenses are displayed when "Software Licence" in the Basic Settings menu is selected.</p>

 **WARNING**

This service information is designed for experienced repair technicians only and is not designed for use by the general public. It does not contain warnings or cautions to advise non-technical individuals of potential dangers in attempting to service a product. Products powered by electricity should be serviced or repaired only by experienced professional technicians. Any attempt to service or repair the product or products dealt with in this service information by anyone else could result in serious injury or death.

# TABLE OF CONTENTS

	PAGE	PAGE
<b>1 Safety Precautions</b> .....	<b>5</b>	
1.1. General guidelines .....	5	
<b>2 Warning</b> .....	<b>6</b>	
2.1. Prevention of Electrostatic Discharge (ESD) to Electrostatic Sensitive (ES) Devices .....	6	
2.2. Precaution of Laser Diode .....	7	
2.3. Service caution based on legal restrictions .....	8	
<b>3 Service Navigation</b> .....	<b>9</b>	
3.1. External HDD (USB-HDD) .....	9	
3.2. How to format for HDD when replacement of HDD or Main P.C.B. ....	12	
3.3. Combination of Multiple Pressing on the Remote Control .....	12	
3.4. Entering Special Modes with Combination of Multiple Pressing on the Remote Control .....	13	
3.5. Description of the Self Diagnosis < Operation Method, Details > .....	15	
3.6. Service Information .....	22	
3.7. Micro Fuse conducting check .....	23	
3.8. (HDD/BD Drive) Service Navigation .....	24	
3.9. Operation check when a USB device is connected .....	26	
3.10. Wi-Fi Module (Internal) Malfunction Check (Simplified Method) .....	27	
3.11. Check with Tuner Service Mode .....	29	
<b>4 Specifications</b> .....	<b>33</b>	
<b>5 Location of Controls and Components</b> .....	<b>35</b>	
<b>6 Installation Instructions</b> .....	<b>38</b>	
6.1. Taking out the Disc from BD Drive Unit when the Disc cannot be ejected by OPEN/CLOSE button .....	38	
<b>7 Service Mode</b> .....	<b>39</b>	
7.1. Self-Diagnosis and Special Mode Setting .....	39	
<b>8 Service Fixture &amp; Tools</b> .....	<b>66</b>	
<b>9 Disassembly and Assembly Instructions</b> .....	<b>67</b>	
9.1. Unit .....	67	
9.2. BD Drive .....	74	
<b>10 Measurements and Adjustments</b> .....	<b>81</b>	
10.1. Service Positions .....	81	
10.2. Caution for Replacing Parts .....	83	
10.3. Standard Inspection Specifications after Making Repairs .....	83	
<b>11 Block Diagram</b> .....	<b>85</b>	
11.1. Overall Block Diagram .....	85	
11.2. Power Supply Block Diagram .....	86	
11.3. Timer Block Diagram .....	87	
11.4. Digital P.C.B. Regulator Block Diagram .....	88	
11.5. Digital Block Diagram (1/2) .....	89	
11.6. Digital Block Diagram (2/2) .....	90	
11.7. CI Block Diagram .....	91	
<b>12 Wiring Connection Diagram</b> .....	<b>92</b>	
12.1. Interconnection Schematic Diagram .....	92	
<b>13 Schematic Diagram</b> .....	<b>93</b>	
<b>14 Printed Circuit Board</b> .....	<b>93</b>	
<b>15 Exploded View and Replacement Parts List</b> .....	<b>93</b>	

# 1 Safety Precautions

## 1.1. General guidelines

1. When servicing, observe the original lead dress. If a short circuit is found, replace all parts which have been overheated or damaged by the short circuit.
2. After servicing, see to it that all the protective devices such as insulation barriers, insulation papers shields are properly installed.
3. After servicing, make the following leakage current checks to prevent the customer from being exposed to shock hazards.

### 1.1.1. Leakage current cold check

1. Unplug the AC cord and connect a jumper between the two prongs on the plug.
2. Measure the resistance value, with an ohmmeter, between the jumpered AC plug and each exposed metallic cabinet part on the equipment such as screwheads, connectors, control shafts, etc. When the exposed metallic part has a return path to the chassis, the reading should be between  $1M\Omega$  and  $5.2M\Omega$ . When the exposed metal does not have a return path to the chassis, the reading must be  $\infty$ .

### 1.1.2. Leakage current hot check (See Figure 1.)

1. Plug the AC cord directly into the AC outlet. Do not use an isolation transformer for this check.
2. Connect a  $1.5k\Omega$ , 10 watts resistor, in parallel with a  $0.15\mu F$  capacitors, between each exposed metallic part on the set and a good earth ground such as a water pipe, as shown in Figure 1.
3. Use an AC voltmeter, with 1000 ohms/volt or more sensitivity, to measure the potential across the resistor.
4. Check each exposed metallic part, and measure the voltage at each point.
5. Reverse the AC plug in the AC outlet and repeat each of the above measurements.
6. The potential at any point should not exceed 0.75 volts RMS. A leakage current tester (Simpson Model 229 or equivalent) may be used to make the hot checks, leakage current must not exceed 1/2 milliampere. In case a measurement is outside of the limits specified, there is a possibility of a shock hazard, and the equipment should be repaired and rechecked before it is returned to the customer.

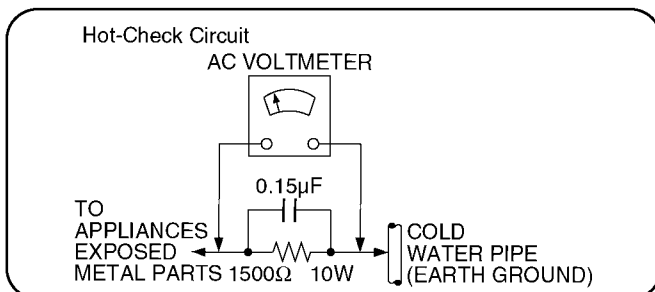

Figure 1

## 2 Warning

### 2.1. Prevention of Electrostatic Discharge (ESD) to Electrostatic Sensitive (ES) Devices

Some semiconductor (solid state) devices can be damaged easily by static electricity. Such components commonly are called Electrostatic Sensitive (ES) Devices. Examples of typical ES devices are integrated circuits and some field-effect transistor-and semiconductor "chip" components. The following techniques should be used to help reduce the incidence of component damage caused by electrostatic discharge (ESD).

1. Immediately before handling any semiconductor component or semiconductor-equipped assembly, drain off any ESD on your body by touching a known earth ground. Alternatively, obtain and wear a commercially available discharging ESD wrist strap, which should be removed for potential shock reasons prior to applying power to the unit under test.
2. After removing an electrical assembly equipped with ES devices, place the assembly on a conductive surface such as aluminum foil, to prevent electrostatic charge buildup or exposure of the assembly.
3. Use only a grounded-tip soldering iron to solder or unsolder ES devices.
4. Use only an anti-static solder removal device. Some solder removal devices not classified as "anti-static (ESD protected)" can generate electrical charge sufficient to damage ES devices.
5. Do not use freon-propelled chemicals. These can generate electrical charges sufficient to damage ES devices.
6. Do not remove a replacement ES device from its protective package until immediately before you are ready to install it. (Most replacement ES devices are packaged with leads electrically shorted together by conductive foam, aluminum foil or comparable conductive material).
7. Immediately before removing the protective material from the leads of a replacement ES device, touch the protective material to the chassis or circuit assembly into which the device will be installed.

#### Caution

Be sure no power is applied to the chassis or circuit, and observe all other safety precautions.

8. Minimize bodily motions when handling unpackaged replacement ES devices. (Otherwise harmless motion such as the brushing together of your clothes fabric or the lifting of your foot from a carpeted floor can generate static electricity sufficient to damage an ES device).

#### IMPORTANT SAFETY NOTICE

There are special components used in this equipment which are important for safety. These parts are marked by  $\triangle$  in the schematic diagrams, Exploded Views and replacement parts list. It is essential that these critical parts should be replaced with manufacturer's specified parts to prevent shock, fire, or other hazards. Do not modify the original design without permission of manufacturer.

## 2.2. Precaution of Laser Diode

### CAUTION:

This product utilizes a laser diode with the unit turned “on”, invisible laser radiation is emitted from the pickup lens.  
Wave length: 783 nm (CDs)/ 661 nm (DVDs)/405 nm (BDs)  
Maximum output radiation power from pickup: 100  $\mu$  W/VDE

Laser radiation from the pickup lens is safety level, but be sure the followings:

1. Do not disassemble the optical pickup unit, since radiation from exposed laser diode is dangerous.
2. Do not adjust the variable resistor on the pickup unit. It was already adjusted.
3. Do not look at the focus lens using optical instruments.
4. Recommend not to look at pickup lens for a long time.

The illustration shows the image of DMR-UBS90EG.

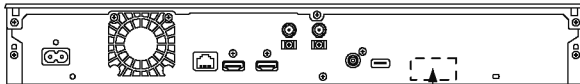

LUOKAN 1 LASERLAITE  
KLASS 1 LASER APPARAT



<b>DANGER</b> - VISIBLE AND INVISIBLE LASER RADIATION WHEN OPEN. AVOID DIRECT EXPOSURE TO BEAM. FDA21 CFR/CLASS IIIb
<b>CAUTION</b> - CLASS 3B VISIBLE AND INVISIBLE LASER RADIATION WHEN OPEN. AVOID EXPOSURE TO THE BEAM. IEC60825-1/CLASS 3B
<b>ATTENTION</b> - RAYONNEMENT LASER VISIBLE ET INVISIBLE CLASSE 3B, EN CAS D'OUVERTURE. EVITER UNE EXPOSITION AU FAISCEAU.
<b>FORSIGTIG</b> - SYNLIG OG USYNLIG LASERSTRÅLING KLASSE 3B, NÅR LÅGET ER ÅBENT. UNDGÅ AT BLIVE UDSAT FOR STRÅLEN.
<b>VARO</b> - AVATTAESSA OLET ALTIINA LUOKAN 3B NÄKYVÄÄ JA NÄKYMÄTÖNTÄ LASERSTRÄLYÄ. VARO ALTIISTUMISTA SÄTEELLE.
<b>WARNING</b> - KLASSE 3B SYNLIG OCH OSYNLIG LASERSTRÅLNING NÄR DENNA DEL ÄR ÖPPNAD. UNDVIK EXPONERING FÖR STRÅLEN.
<b>VORSICHT</b> - SICHTBARE UND UNSICHTBARE LASERSTRÄHLUNG KLASSE 3B. WENN ABDECKUNG GEÖFFNET, NICHT DEM STRAHL AUSSETZEN.
<b>注意</b> - 打开时有可见及不可见激光辐射。避免光束照射。
<b>注意</b> - ここを開くとクラス3Bの可視及び不可視レーザー放射が出る。ビームの目又は皮膚への照射は危険! 長時間の照射は危険! VQL2Q40

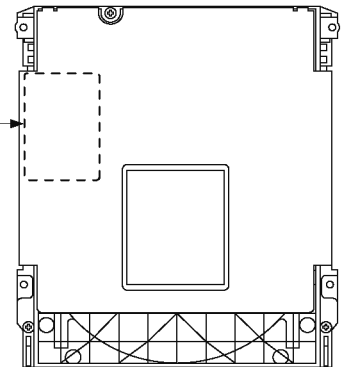

### ACHTUNG:

Dieses Produkt enthält eine Laserdiode.  
Im eingeschalteten Zustand wird unsichtbare Laserstrahlung von der Lasereinheit abgestrahlt.  
Wellenlänge: 783 nm (CDs)/ 661 nm (DVDs)/ 405 nm (BDs)

Maximale Strahlungsleistung der Lasereinheit: 100  $\mu$  W/VDE

Die Strahlung der Lasereinheit ist ungefährlich, wenn folgende Punkte beachtet werden:

1. Die Lasereinheit nicht zerlegen, da die Strahlung an der freigelegten Laserdiode gefährlich ist.
2. Den werkseitig justierten Einstellregler der Lasereinheit nicht verstellen.
3. Nicht mit optischen Instrumenten in die Fokussierlinse blicken.
4. Nicht über längere Zeit in die Fokussierlinse blicken.

### CAUTION!

THIS PRODUCT UTILIZES A LASER.

USE OF CONTROLS OR ADJUSTMENTS OR PERFORMANCE OF PROCEDURES OTHER THAN THOSE SPECIFIED HEREIN MAY RESULT IN HAZARDOUS RADIATION EXPOSURE.

## 2.3. Service caution based on legal restrictions

### 2.3.1. General description about Lead Free Solder (PbF)

The lead free solder has been used in the mounting process of all electrical components on the printed circuit boards used for this equipment in considering the globally environmental conservation.

The normal solder is the alloy of tin (Sn) and lead (Pb). On the other hand, the lead free solder is the alloy mainly consists of tin (Sn), silver (Ag) and Copper (Cu), and the melting point of the lead free solder is higher approx.30 degrees C (86°F) more than that of the normal solder.

#### Definition of PCB Lead Free Solder being used

The letter of "PbF" is printed either foil side or components side on the PCB using the lead free solder. (See right figure)	<b>PbF</b>
---	------------

#### Service caution for repair work using Lead Free Solder (PbF)

- The lead free solder has to be used when repairing the equipment for which the lead free solder is used.  
(Definition: The letter of "PbF" is printed on the PCB using the lead free solder.)
- To put lead free solder, it should be well molten and mixed with the original lead free solder.
- Remove the remaining lead free solder on the PCB cleanly for soldering of the new IC.
- Since the melting point of the lead free solder is higher than that of the normal lead solder, it takes the longer time to melt the lead free solder.
- Use the soldering iron (more than 70W) equipped with the temperature control after setting the temperature at 350±30 degrees C (662±86°F).

#### Recommended Lead Free Solder (Service Parts Route.)

- The following 3 types of lead free solder are available through the service parts route.
  - SVKZ000001 ----- (0.3mm 100g Reel)
  - SVKZ000002 ----- (0.6mm 100g Reel)
  - SVKZ000003 ----- (1.0mm 100g Reel)

#### Note

\* Ingredient: tin (Sn), 96.5%, silver (Ag) 3.0%, Copper (Cu) 0.5%. (Flux cored)

## 3 Service Navigation

### 3.1. External HDD (USB-HDD)

**Please use a confirmed USB-HDD.**

For the latest information on confirmed USB-HDDs, please check the following website.  
<http://panasonic.jp/support/global/cs/>

- Certain non-confirmed USB-HDDs cannot be used with this unit.
- If a problem occurs with the USB-HDD, please contact the manufacturer of the device.

#### 3.1.1. Connecting the USB-HDD

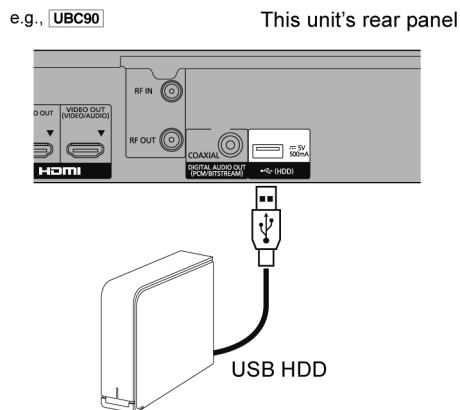

Connect this unit with optional USB-HDD.

- Only one USB-HDD (For recorded titles) can be connected at the same time.
- Do not connect additional HDDs using a USB hub.
- For details about connection method, refer to the instructions supplied with the USB-HDD.

#### 3.1.2. Disconnecting the USB-HDD

Please use the following procedure to disconnect.

Disconnecting without following this procedure may result in the loss of recorded content from the USB-HDD or the internal HDD.

1. Press [FUNCTION MENU].
2. Select "Setup" in "FUNCTION MENU", then press [OK].
3. Select "Basic Settings" in "Setup (Adjustment for Recorder functions.)", then press [OK].
4. Select "HDD/ Disc/ USB-HDD" in "Basic Settings", then press [OK].
5. Select "Settings for USB-HDD" in "HDD/ Disc/ USB-HDD", then press [OK].
6. Select "USB-HDD Disconnection", then press [OK].
7. Select "Yes", then press [OK].
8. Disconnect the USB-HDD from this unit.

#### 3.1.3. Registering the USB-HDD

##### 3.1.3.1. Registering the USB-HDD

- If you use a USB-HDD with this unit, the USB-HDD must first be registered on this unit.
  - Registering of a USB-HDD will format the USB-HDD and all the content already recorded will be deleted.
  - Up to eight USB-HDDs can be registered on this unit.
  - Registered USB-HDDs cannot be used with devices other than this unit.
- If the registering screen appears when connecting the USB-HDD, go to step 7.
  1. Press [FUNCTION MENU].
  2. Select "Setup" in "FUNCTION MENU", then press [OK].
  3. Select "Basic Settings" in "Setup (Adjustment for Recorder functions.)", then press [OK].
  4. Select "HDD/ Disc/ USB-HDD" in "Basic Settings", then press [OK].
  5. Select "Settings for USB-HDD" in "HDD/ Disc/ USB-HDD", then press [OK].
  6. Select "USB-HDD Registration", then press [OK].
  7. Select "Yes", then press [OK].
    - If you have already registered eight USB-HDDs, it will be necessary to delete one or more of them before registering a new USB-HDD.

The message screen appears:

  1. Select "Yes", then press [OK].
  2. Select the USB-HDD to cancell, then press [OK]. The confirmation screen appears.
  3. Select "Yes", then press [OK].

8. When the registering is complete, message screen appears.  
Press [OK].
9. The confirmation screen appears.  
Press [OK].

### **3.1.3.2. Settings for USB-HDD**

#### **Delete all titles**

Delete all titles on the USB-HDD.

- Delete does not work if one or more titles are protected.

1. Press [FUNCTION MENU].
2. Select "Setup" in "FUNCTION MENU", then press [OK].
3. Select "Basic Settings" in "Setup (Adjustment for Recorder functions.)", then press [OK].
4. Select "HDD/ Disc/ USB-HDD" in "Basic Settings", then press [OK].
5. Select "Settings for USB-HDD" in "HDD/ Disc/ USB-HDD", then press [OK].
6. Select "USB-HDD Management", then press and hold [OK] for 3 seconds.
7. Select "Delete all titles", then press [OK].
8. Select "Yes" and press [OK].
9. Select "Start" and press [OK].
10. The confirmation screen appears.  
Press [OK].

#### **Format USB-HDD**

Formatting deletes all contents, and they cannot be restored.

Check carefully before proceeding.

1. Press [FUNCTION MENU].
2. Select "Setup" in "FUNCTION MENU", then press [OK].
3. Select "Basic Settings" in "Setup (Adjustment for Recorder functions.)", then press [OK].
4. Select "HDD/ Disc/ USB-HDD" in "Basic Settings", then press [OK].
5. Select "Settings for USB-HDD" in "HDD/ Disc/ USB-HDD", then press [OK].
6. Select "USB-HDD Management", then press and hold [OK] for 3 seconds.
7. Select "Format USB-HDD", then press [OK].
8. Select "Yes" and press [OK].
9. Select "Start" and press [OK]. Then formatting starts.
10. Press [OK] after formatting completed.

### **3.1.3.3. To cancell all USB-HDD registrations**

- If you register a USB-HDD, all the content already recorded on the USB-HDD will be deleted.
- It is not possible to play back the content on the USB-HDD whose registration has been cancelled.
- You can check the registration number of the USB-HDD on the DIRECT NAVIGATOR.

#### **Cancellation of all USB-HDD Registrations**

This function cancels the registrations of all the USB-HDDs registered on this unit.

Only do this if you are going to dispose of this unit.

- Before operation, perform "3.1.2. Disconnecting the USB-HDD" and remove the USB-HDD.

- It is not possible to play back the content from a USB-HDD whose registration has been cancelled.

1. Press [FUNCTION MENU].
2. Select "Setup" in "FUNCTION MENU", then press [OK].
3. Select "Basic Settings" in "Setup (Adjustment for Recorder functions.)", then press [OK].
4. Select "HDD/ Disc/ USB-HDD" in "Basic Settings", then press [OK].
5. Select "Settings for USB-HDD" in "HDD/ Disc/ USB-HDD", then press [OK].
6. Select "Cancellation of all USB-HDD Registrations", then press and hold [OK] for 3 seconds.
7. Select "Yes", then press [OK].
8. The confirmation screen appears.  
Select "Yes", and press [OK].
9. When the cancellation is complete, message screen appears.  
Press [OK].

### 3.1.3.4. Registration procedure of USB-HDD for inspection

This function registers a USB-HDD for inspection aside from 8 USB-HDDs that can be registered in Normal mode.

If the USB-HDD for inspection is registered in User mode, it cannot be erased. Make sure to use Special mode to register the USB-HDD for inspection.

#### Registration procedure

1. Perform "3.4.3. Nondisclosure mode 2" to enter the Service mode.
2. Press the [7][4] buttons of remote control in the Service mode to enter the Special mode.
3. If the new USB-HDD is connected, it is automatically formatted/registered. (There is no TV monitor display for registration.)  
The USB-HDD registered in the Special mode can be operated using the same functions (format, record/play/edit, dubbing) as those for USB-HDDs registered in the Normal mode.  
The Special mode can be cancelled at power "OFF" only. (Cancelling the Special mode will erase the registration in the Special mode.)

### 3.1.4. Operation check when USB HDD is connected

Check the operation status (normal or abnormal) of the USB connection part as follows.

1. Press [FUNCTION MENU].
2. Select "Setup" in "FUNCTION MENU", then press [OK].
3. Select "Basic Settings" in "Setup (Adjustment for Recorder functions.)", then press [OK].
4. Select "HDD/ Disc/ USB-HDD" in "Basic Settings", then press [OK].
5. Select "Settings for USB-HDD" in "HDD/ Disc/ USB-HDD", then press [OK].
6. Select "USB-HDD Registration", then press [OK].

#### Normal operation:

The registered USB-HDD is automatically displayed when connected.

(\*Displayed items differ depending on the connected USB-HDD.)

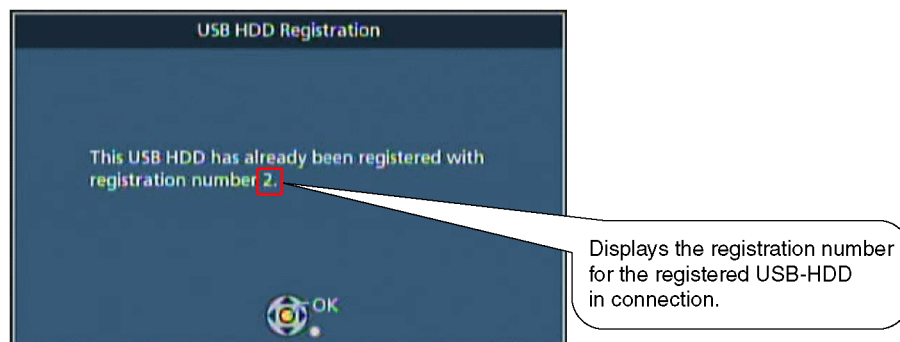

#### Abnormal operation (1):

When the USB-HDD cannot be detected, "Cannot detect USB HDD." etc. will be automatically displayed.

(\*When the cable (USB cable) between the main unit and the USB-HDD is poorly connected (cable disconnection), etc.)

#### Abnormal operation (2):

When a wrong USB-HDD incompatible with this unit is connected, "Connected USB device cannot be used with this unit.", etc. will be automatically displayed.

(\*Incompatible USB-HDD: When devices with capacity of less than 160GB or more than 3TB or other USB devices are connected)

#### Abnormal operation (3):

When more than 1 USB-HDD are connected at the same time, "Registration of USB HDD must be done with only one USB storage device connected.", etc. will be automatically displayed.

#### Abnormal operation (4):

When a USB-HDD compatible only with USB 1.1 or below is connected, "Connected USB device cannot be used with this unit.", etc. will be automatically displayed.

## 3.2. How to format for HDD when replacement of HDD or Main P.C.B.

### 3.2.1. How to escape " HDD Error " indication on GUI display.

1. When exchange HDD or Main P.C.B., the " HDD Error " screen is displayed, but, according to a following procedure, please format HDD.

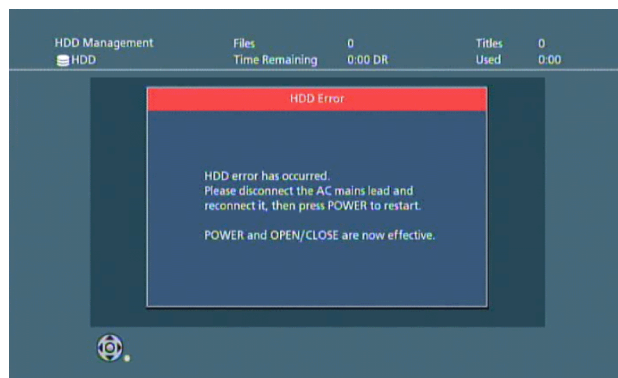

2. Press power button to turn off the power first, then turn on the power with the [ GUIDE ] button on remote-control. (Shown in Reference screen 1)

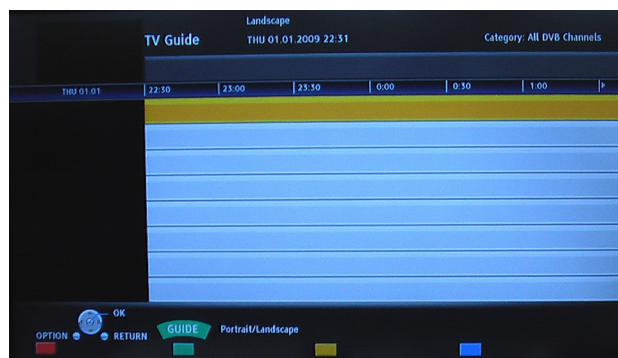

(Reference screen 1)

3. Press [ RETURN ] button to move to the normal display.

### 3.2.2. Procedure of the " HDD format ".

1. Press [FUNCTION MENU].
2. Select "Setup" in "Others", then press [OK].
3. Select " HDD/Disc/USB-HDD " and press [OK].
4. Select " HDD Management " and press [OK] for 3 seconds.
5. Select " Format HDD " and press [OK].
6. Select " Yes " and press [OK].
7. Select " Start " and press [OK]. Then formatting starts.
8. Press [OK] after formatting completed.
9. Press [RETURN] to exit setting mode.

## 3.3. Combination of Multiple Pressing on the Remote Control

Press multi-buttons (in combination) on the remote control simultaneously for operations, such as initialization or service mode, etc. There are no multiple pressing functions on the previous remote controls, thus, please be sure to use the supplied remote control.

### 3.4. Entering Special Modes with Combination of Multiple Pressing on the Remote Control

Enter the following special modes by multiple pressing functions on the supplied remote control. After entering each mode, switch to the desired menus for operation.

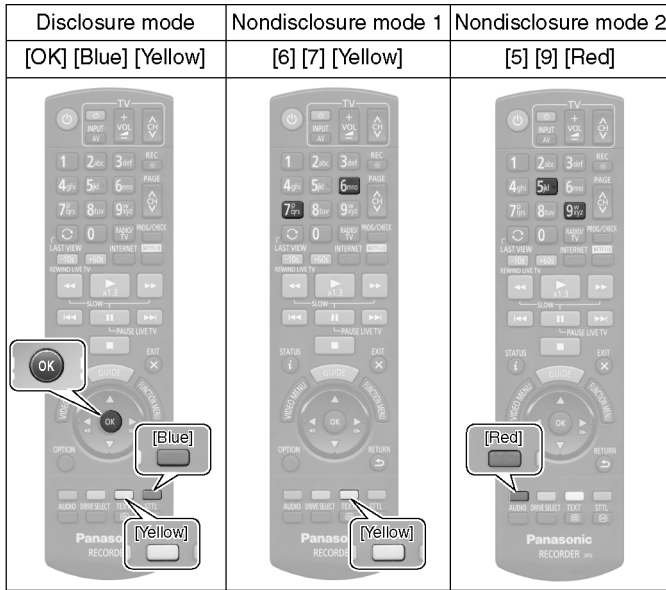

◆ **Menu switch:** ↓ mark.  
[▶] (remote control)  
or  
[Power] (main unit)

◆ **Operating menu:**  
[OK] (remote control)  
or  
[O/C] (main unit)

※ Release from special modes automatically after the operation.

◆ **Release from special modes:**

- Press other buttons in no connection with the above operations.
- No operation for over 2 minutes.
- Press and hold [Power] on main unit (forced to turn off).

#### 3.4.1. Disclosure mode (Combination of multiple pressing: [OK] [Blue] [Yellow])

Press and hold [OK] [Blue] [Yellow] on the remote control simultaneously for 5 sec., then "00 RET" is displayed on FL display window.

Power	Disc	FL display	Key operation	Function	Remarks
OFF	Yes/No	00 RET	No	No	
		↓	06 FT0	OK	Force tray open
ON	Yes/No	00 RET	No	No	
	No	03 VL	OK	Release from BD/DVD video play restriction	Release from the aging restriction on BD video and DVD video play.
	Yes/No	04 PRG	OK (Press and hold)	Progressive initialization	Initialize the progressive settings, and switch to the interlaced display. Press and hold [Stop] (not [OK])(on the remote control or main unit) to switch to "10 OCL" (setting shop lock mode).
	Yes/No	05 P/N	OK (Press and hold)	Switch the TV System	It returns to the default side (PAL). The change of PAL and NTSC can be performed in the following procedure. The unit's TV System is different from that of the disc. While stopped, keep pressing [OK] on the remote control. The system switches from PAL to NTSC or vice versa.
	Yes/No	07 DC	OK (Press and hold)	Deep Color initialization	Initialize Deep Color.
	Yes/No	13 L4K	OK (Press and hold)	Set 4k/60p output to "OFF".	Set 4k/60p output to "OFF", and set the output to HDMI (Ver. 1.4) equivalent.
	Yes	10 OCL	OK	Shop lock mode setting/release ([O/C] is invalid/valid, while setting/release this mode.)	When "04 PRG" is displayed, press and hold [Stop] (on the remote control or main unit) to switch to other displays. Press [OK] to only lock the tray switch. * Even turn ON/OFF the power, it is still in locking.

### 3.4.2. Nondisclosure mode 1 (Combination of multiple pressing: [6] [7] [Yellow])

Press and hold [6] [7] [Yellow] on the remote control simultaneously for 5 sec., then "50 RET" is displayed on FL display window.

Power	Disc	FL display	Key operation	Function	Remarks
ON	No	50 RET	No	No	
		↓			
		51 NOP	OK	No	When "51 NOP" is displayed, press and hold [Stop] (on the remote control or main unit) to switch to "52 BRE" (delete BD-ROM history settings).
		52 BRE	OK	BD-ROM history delete	When "51 NOP" is displayed, press and hold [Stop] (on the remote control or main unit) to switch to other displays. Press [OK] to delete BD video history.

### 3.4.3. Nondisclosure mode 2 (Combination of multiple pressing: [5] [9] [Red])

Press and hold [5] [9] [Red] on the remote control simultaneously for about 5 sec., then "70 RET" is displayed on FL display window.

Power	Disc	FL display	Key operation	Function	Remarks
OFF	Yes/No	70 RET	No	No	
		↓			
		80 SRV	OK	Switch to service mode	Press [OK], then "Welcome" is displayed, and wait about 30 sec. until "SERV" is displayed.
		↓			
		83 SDI	OK	CD/SD Diag	Do not apply in normal service.
ON	Yes/No	91 SPD	OK	Special display	Do not apply in normal service.
		↓			
		92 F99	OK	F99 Validate/Invalidate switch	Do not apply in normal service.
		↓			
		70 RET	No	No	
		↓			
		81 AIG	OK	Switch to aging mode	
↓					
82 TSR	OK	Switch to tuner service mode			
↓					
83 SDI	OK	CD/SD Diag	Do not apply in normal service.		
↓					
91 SPD	OK	Special display	Do not apply in normal service.		
↓					
92 F99	OK	F99 Validate/Invalidate switch	Do not apply in normal service.		
↓					
93 FIN	OK (Press and Hold)	Restore the factory settings	All settings included Quick setting and Network settings restored the factory settings. In this mode, the following item is unclearable. <ul style="list-style-type: none"> <li>▪ Error History</li> <li>▪ Last error of Drive</li> <li>▪ Used time of HDD</li> <li>▪ Used time of Drive Laser</li> </ul>		
↓					
96 DIC	OK	Self Diagnosis	To make it easy to demarcate a fault occurrence section.		

### 3.5. Description of the Self Diagnosis < Operation Method, Details >

#### 3.5.1. How to check the diagnosis code

This device can display the device information with a 16 digit number (Diagnosis code) on the monitor in order to promptly check the device status.

##### 3.5.1.1. Procedure of the diagnosis code check

1. Turn power on. (E-E mode without recording or running as a server)
2. Press and hold [5], [9] and [Red] buttons on the remote control simultaneously for 5 seconds or more until front display indicates "70 RET" as shown below.

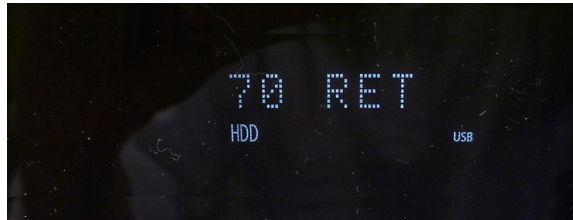

3. Press [POWER] button on the main unit or [▶] on the remote control several times until front display indicates "96 DIC".  
Front display indicates as follows by pressing [POWER] or [▶] button.

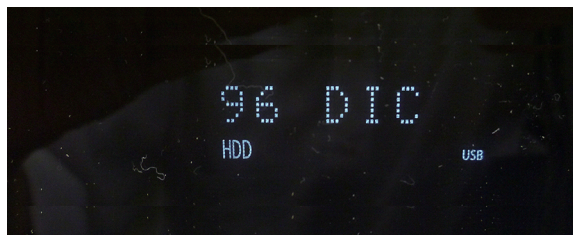
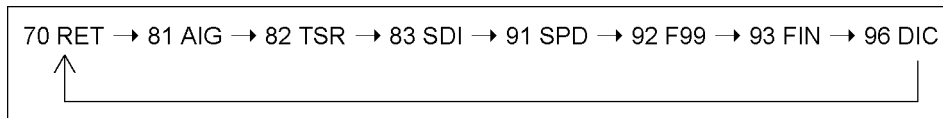

- \* If front display indicates "-- --" or enter to the other mode, reset by pressing [POWER] button and repeat from first step.
4. Press [OPEN/CLOSE] button on the main unit or [OK] button on the remote control to run self diagnosis.

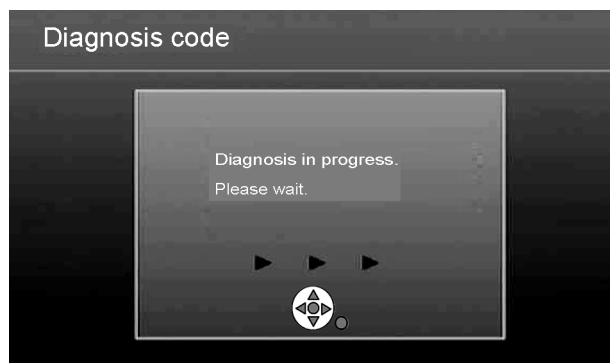

5. Press [OK] and then following "Diagnosis Code" will be displayed.

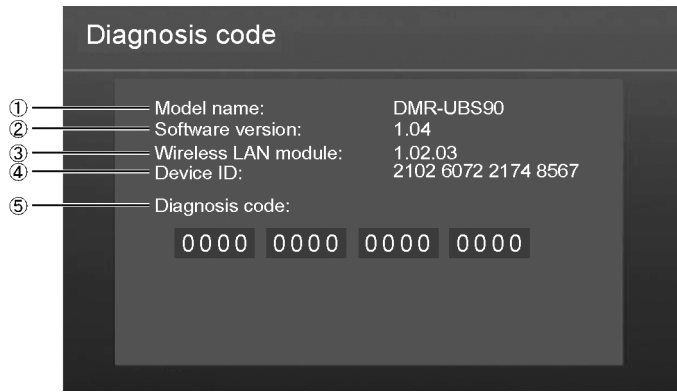

Item	Details	
① Model Name	Display the model name	
② Software version	Display the software version	
③ Wireless LAN module	Display the wireless LAN module version (Built-in wireless LAN model)	
	Wireless LAN adapter	Display the wireless LAN adaptor module version (Wireless LAN adaptor applicable model)
	(No display)	Wireless LAN unsupported model
④ Device ID	Display the device ID	
⑤ Diagnosis code	Display the diagnosis code	

**Release from self Diagnosis mode:**

1. Press the [POWER] button on the main Unit.

**3.5.1.2. Description of the self diagnosis code**

self diagnosis code details:

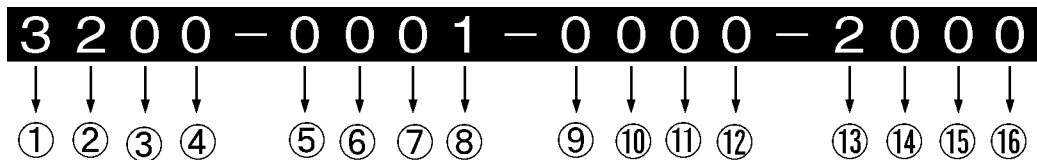

Diagnosis details		Diagnosis details	
① Drive		⑨ HDMI terminal 2 (DMR-UBS90EG)	
② HDD		⑩ Reserved ("0" displays always)	
③ Reserved ("0" displays always)		⑪ Reserved ("0" displays always)	
④ USB-HDD diagnosis		⑫ Reserved ("0" displays always)	
⑤ Digital P.C.B. (CPU/Flash/DDR/HDMI etc.)		⑬ Failure history of Drive/HDD/FAN	
⑥ TUNER system		⑭ Reserved ("0" displays always)	
⑦ Reserved ("0" displays always)		⑮ Reserved ("0" displays always)	
⑧ Main P.C.B. (EEPROM)		⑯ Reserved ("0" displays always)	

\* If the power does not turn on or CPU does not work properly, self diagnosis will not run. In that case, check the power supply or P.C.B. connection.

## Specifications of Diagnostic Code

### 1. BD Drive

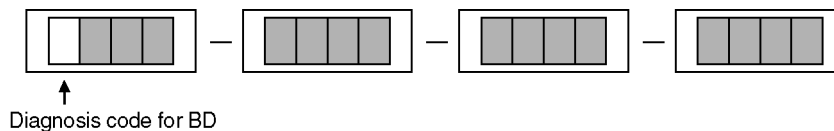

#### < Diagnosis Result >

0	No trouble found on the drive. Please check other diagnosis items.
1	Unable to communicate with the drive. Check any problems with connection of Drive FPC, power supply cable for drive or power supply circuit. If no trouble found, there is a high possibility of drive unit failure itself.
2	Drive unit failure itself.
3	Error caused by disk or disc control. If this error appears only in specific disk, check whether the same error appears with other discs playback. Check the cable connection to drive. If the turntable is dirty, clean it up to avoid slip of disc. If the disk cannot be read/written properly after cleaning, drive unit replacement may be necessary.
8	Unable to execute the diagnosis function properly. There is a possibility of malfunction on the digital P.C.B.
9	Error diagnosed as unsupported drive. Drive unit replacement is necessary.
Other	Try to run self diagnosis again.

**Example: BD Drive is not recognizable.**

Diagnosis code

Model name: DMR-UBS90  
 Software version: 1.04  
 Wireless LAN module: 1.02.03  
 Device ID: 2102 6072 2174 8567

Diagnosis code:  
 1000 0000 0000 0000

## 2. HDD

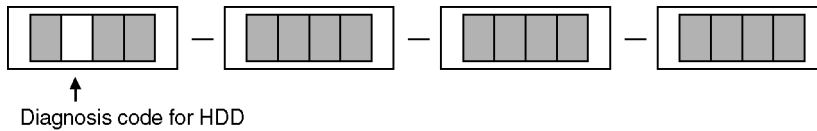

### < Diagnosis Result >

0	No trouble found on HDD. Please check other diagnosis items.
1	Unable to communicate with HDD. Check any problems with connection of all cables for HDD or power supply circuit. If no trouble found, there is a high possibility of drive unit failure itself.
2	HDD failure itself. Replace it.
8	Unable to execute the diagnosis function properly. There is a possibility of malfunction on the digital P.C.B.
Other	Try to run self diagnosis again.

### Example: HDD is not recognizable.

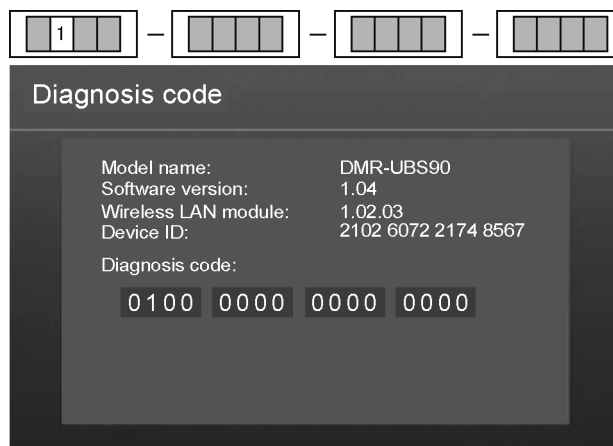

### 3. USB HDD Diagnosis

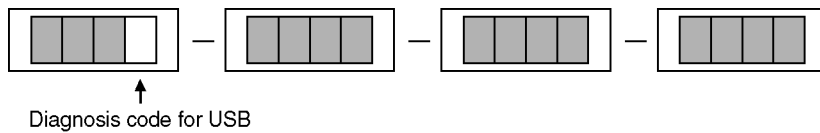

#### < Diagnosis Result >

0	No trouble found on USB HDD. Please check other diagnosis items.
1	No USB HDD is connected or some other device is connected. Check connection of USB cable or power supply circuit. If no trouble found, there is a high possibility of USB HDD failure itself.
2	USB HDD failure itself. Replace it.
6	Several USB HDD are connected.
7	Unsupported USB HDD is connected.
8	Unable to execute the diagnosis function properly. There is a possibility of malfunction on the digital P.C.B.
Other	Try to run self diagnosis again.

**Example: USB HDD is not recognizable.**

Diagnosis code

Model name: DMR-UBS90  
 Software version: 1.04  
 Wireless LAN module: 1.02.03  
 Device ID: 2102 6072 2174 8567

Diagnosis code:  
 0001 0000 0000 0000

#### 4. Digital P.C.B./Tuner/Main P.C.B. System Diagnosis

##### (1) IC communication on the digital P.C.B. (CPU and Flash/DDR/HDMI, etc.)

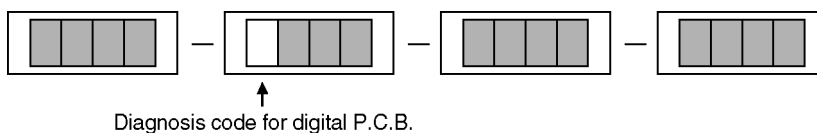

##### < Diagnosis Result >

0	No trouble found on the digital P.C.B.
1	Communication error between CPU and FLASH/DDR. There is a high possibility of parts failure on the digital P.C.B.
2	Communication error between CPU and HDMI-LSI, There is a high possibility of parts failure on the digital P.C.B.
3	Communication error between CPU and FLASH/DDR, and between CPU and HDMI-LSI. Take measures of above "1" or "2".
4	HDMI-CEC circuit is not worked properly. There is a high possibility of parts failure on the digital P.C.B.
5	Communication error between CPU and FLASH/DDR, and HDMI-CEC circuit is not worked properly. Take measures of above "1" and "4".
6	Communication error between CPU and HDMI-LSI, and HDMI-CEC circuit is not worked properly. Take measures of above "2" and "4".
7	Communication error between CPU and FLASH/DDR, between CPU and HDMI-LSI and HDMI-CEC circuit is not worked properly. Take measures of above "3" and "4".
Other	Try to run self diagnosis again.

##### (2) IC Communication of TUNER System

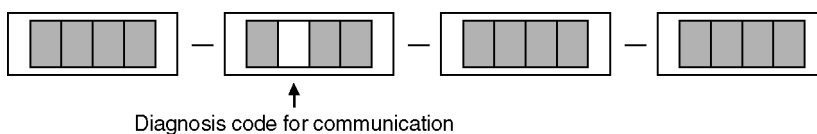

##### < Diagnosis Result >

0	No communication error between digital tuner and IC.
1	Communication error between digital tuner (OFDM/digital modulation IC) and IC. There is a high possibility of digital tuner (OFDM/digital modulation IC) defect, or communication failure between ICs.
2	Communication error between the digital tuner (LNB/digital modulation IC) and IC. There is a high possibility of digital tuner (LNB/Digital Modulation IC) defect, or communication failure between ICs.
3	Communication error between digital tuner (OFDM/digital modulation IC) and IC, Digital Tuner (LNB/Digital Tuner Modulation IC) and IC. There is a high possibility of Digital Tuner (OFDM/Digital Modulation IC) defect, Digital Tuner (LNB/Digital Modulation IC) defect, or a communication failure between ICs.
Other	Try to run self diagnosis again.

**(3) Main P.C.B. IC communication (e.g. EEPROM)**  
**Digital P.C.B. IC communication (e.g. Ether)**

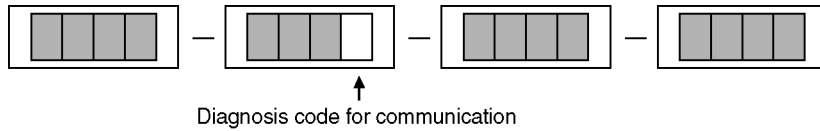

**< Diagnosis Result >**

0	No trouble found.
2	Communication error between the EEPROM of Main P.C.B. and IC. Check the connection between digital P.C.B. and Main P.C.B. If no trouble found, malfunction on the Main P.C.B. is suspected.
4	Communication error between CPU and ETHER-LSI. There is a high possibility of parts failure on the digital P.C.B.
6	Communication error between CPU and EEPROM of Main P.C.B., and CPU and ETHER-LSI. Take measures of above "2" and "4".
Other	Try to run self diagnosis again.

**Example: Communication error between Ether-LSI and CPU**

Diagnosis code

Model name: DMR-UBS90  
 Software version: 1.04  
 Wireless LAN module: 1.02.03  
 Device ID: 2102 6072 2174 8567  
 Diagnosis code:  
 0000 0004 0000 0000

**5. HDMI (SUB) Diagnosis (DMR-UBS90EG)**

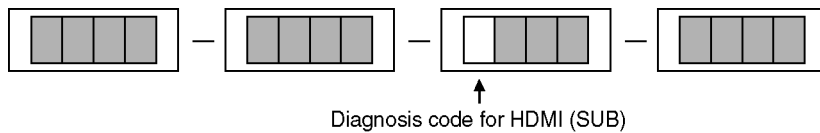

**< Diagnosis Result >**

0	No trouble found on the digital P.C.B.
2	Communication error between CPU and HDMI-LSI, There is a high possibility of parts failure on the digital P.C.B.
Other	Try to run self diagnosis again.

## 6. Failure History and motor

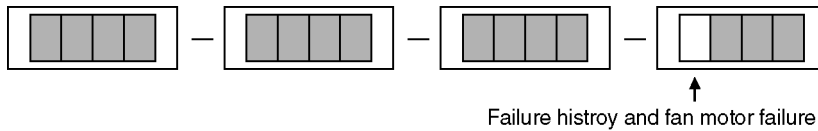

### < Diagnosis Result >

0	No error history
1	If there is error in drive diagnosis, there is a possibility that the drive itself fails. * Refer to the drive diagnosis results. If there is no error in drive diagnosis, there is a possibility that the cause of malfunction is on the digital P.C.B.
2	If there is error in HDD diagnosis, there is a possibility that HDD itself fails. * Refer to HDD diagnosis results. If there is no error in HDD diagnosis, there is a possibility that the cause of malfunction is on the digital P.C.B.
3	There are errors in drive diagnosis and HDD diagnosis. Take measures of above "1" and "2".
4	Fan motor may fail. Check fan motor cable or related circuit.
5	There is error in drive diagnosis and the fan motor may fail. Take measures of above "1" and "4".
6	There is error in HDD diagnosis and the fan motor may fail. Take measures of above "2" and "4".
7	There are errors in HDD, drive diagnosis and the fan motor may fail. Take measures of above "3" and "4".
Other	Try to run self diagnosis again.

### Example: Fan motor may fail

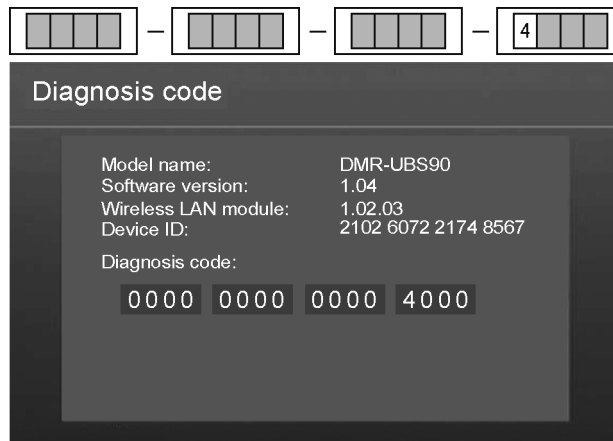

## 3.6. Service Information

This service manual contains technical information which will allow service personnel's to understand and service this model. Please place orders using the parts list and not the drawing reference numbers.

### 3.7. Micro Fuse conducting check

This unit uses the Micro Fuse.

Check the Micro Fuse conducting using the Tester at the check points below.

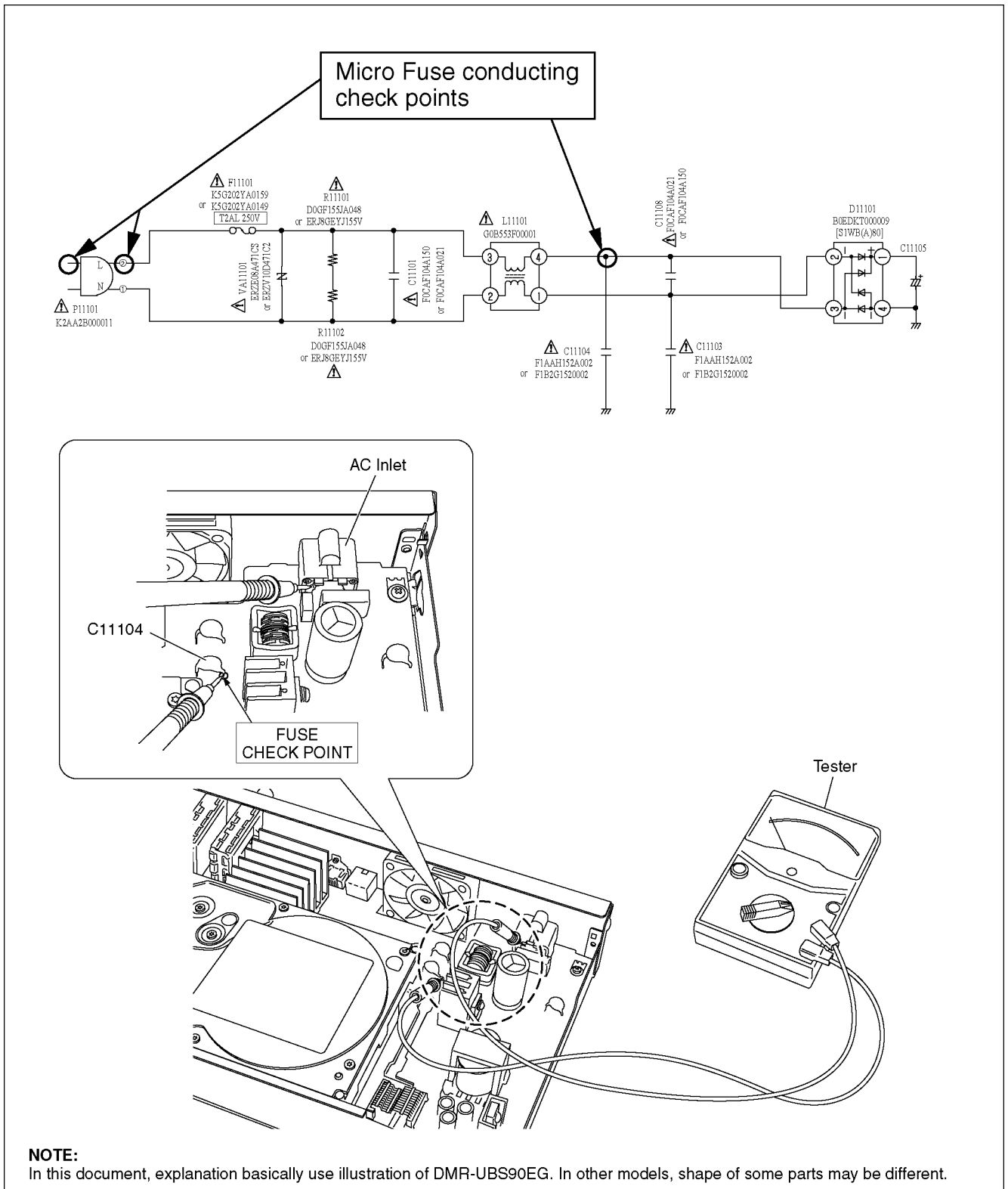

## 3.8. (HDD/BD Drive) Service Navigation

### 3.8.1. HDD/BD Drive Malfunction check (Simplified Method)

Perform simple quality judgement process of HDD/BD Drive according to the following operations.

1. Execute Service Mode
  - 1) Turn the power off.
  - 2) Press the [5] [9] and [RED] button simultaneously for 5 seconds, then "70 RET" is displayed on FL.
  - 3) Press the [▶] button to select until "80 SRV" is displayed on FL.
  - 4) Press the [OK] button.
  - 5) It is displayed on FL as "Welcome-->SERV".: It is shown to have entered the service mode.
2. Press [3] [8] of remote control keys in service mode.
3. Judge the quality on FL display.

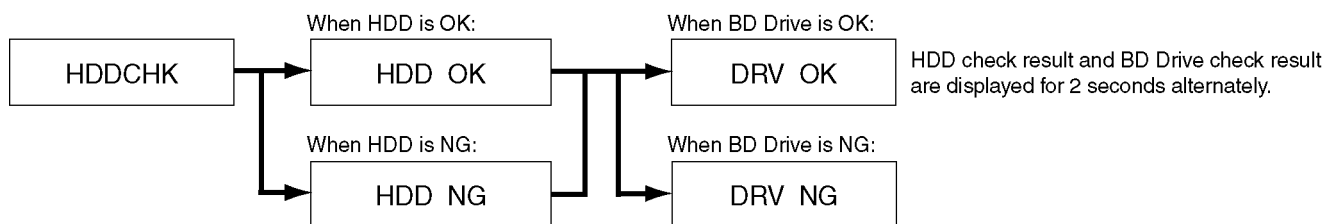

※ If the current date or the date when the error occurred is wrong, correct judgement may not be made.

### 3.8.2. BD Drive Operation check flow

Perform quality judgement process of BD Drive according to the following operation.

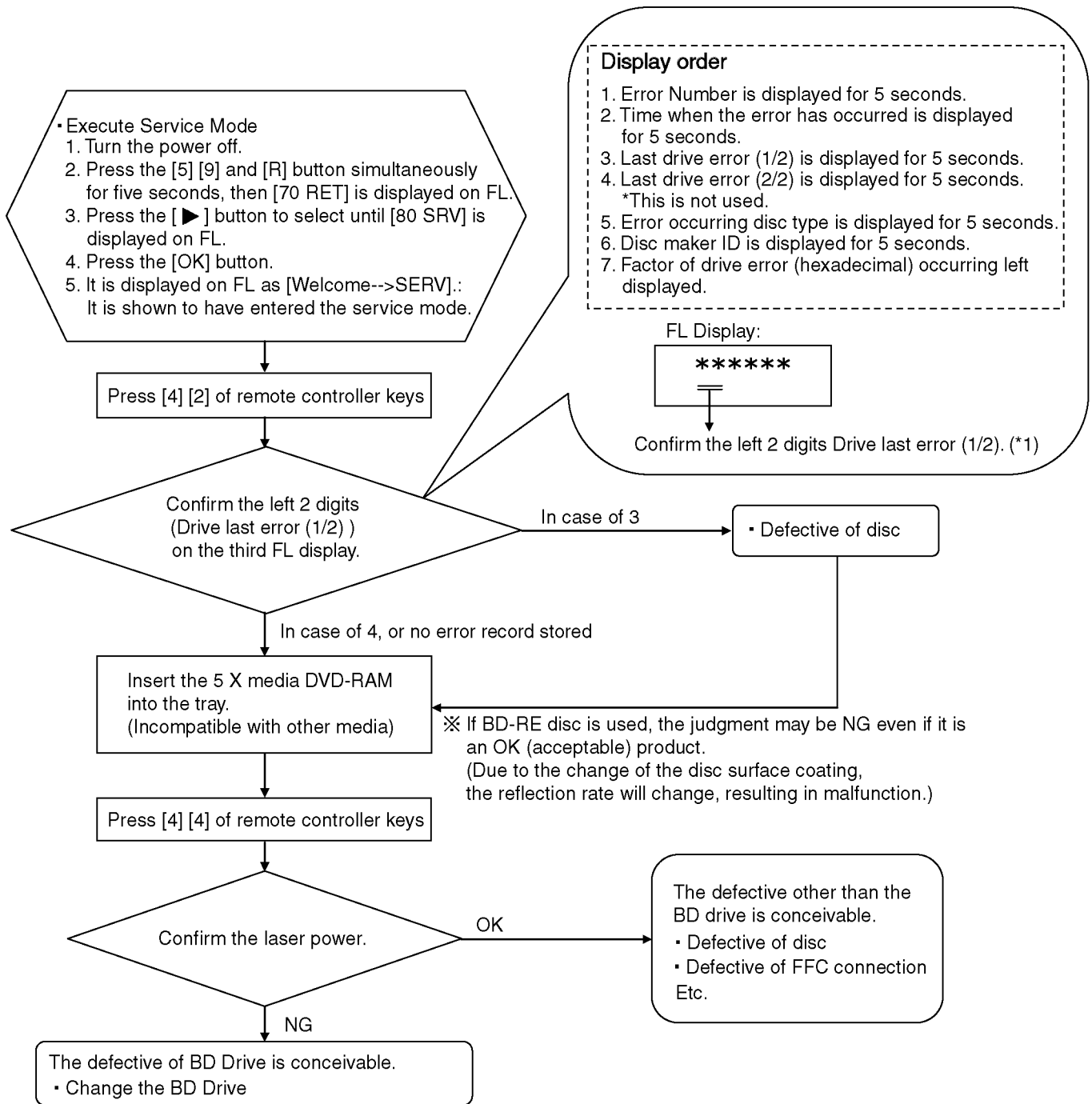

\*1: The drive supports the following error sense keys:

Contents	Sense key	Description
NO SENSE	00	Successful completion.
RECOVERED ERROR	01	Successful completion through recovery.
NOT READY	02	The drive is unable to access the disc.
MEDIUM ERROR	03	An error caused by medium error has occurred.
HARDWARE ERROR	04	An error caused by the drive hardware has occurred.
ILLEGAL REQUEST	05	The CDB or parameter is illegal.
UNIT ATTENTION	06	The drive is alerting the host to some event.
DATA PROTECTED	07	The disc is read-protected or write-protected.
ABORTED COMMAND	0B	The drive has aborted an I/O process or command execution due to a reason not relevant to any other sense key, for example, a protocol violation on the interface.

### 3.9. Operation check when a USB device is connected

You can check the operation status (normal or abnormal) of the USB connection part of this unit easily as shown below.

Connect each device to the USB terminal on the front panel and check the operation status on the TV monitor.

#### Normal operation:

Automatically displayed when the USB connection is made to a digital camera, etc.

(Example below: When motion video materials have been recorded)

(\*Displayed items differ depending on the recorded contents.)



Abnormal operation (Example 1):

Warning is displayed automatically if overcurrent is detected when a USB device is connected.

(\*When a USB device or this unit's USB terminal shorts out or the power supply type of USB device is connected)



Abnormal operation (Example 2):

When the terminal of USB device is damaged or open, there is no display on the TV monitor.

## 3.10. Wi-Fi Module (Internal) Malfunction Check (Simplified Method)

### 3.10.1. Procedure of the Wi-Fi Module (Internal) Malfunction Check

#### 3.10.1.1. Method of Wireless LAN Setting

1. Press [FUNCTION MENU].
2. Select "Setup" in "FUNCTION MENU", then press [OK].
3. Select "Basic Settings" in "Setup (Adjustment for Recorder functions.)", then press [OK].
4. Select "Network" in "Basic Settings", then press [OK].
5. Select "Network Settings" in "Network", then press [OK].
6. Select "Wireless" in "LAN Connection Mode".
7. Press [OK]. The following "Wireless Setting screen (example)" is displayed.

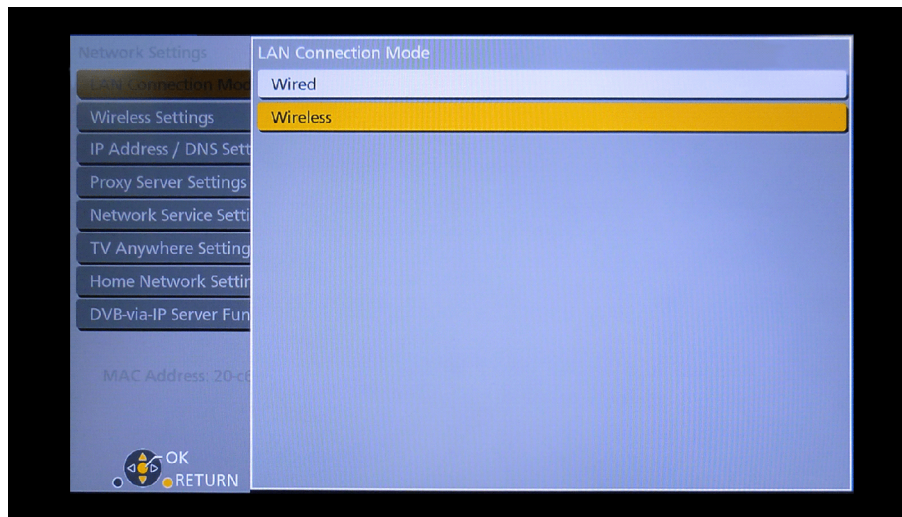

#### 3.10.1.2. Method of displaying Wireless LAN Module Version

1. Press [FUNCTION MENU].
2. Select "Setup" in "FUNCTION MENU", then press [OK].
3. Select "Basic Settings" in "Setup (Adjustment for Recorder functions.)", then press [OK].
4. Select "Others" in "Basic Settings", then press [OK].
5. Select "System Information" in "Others".
6. Press [OK]. The following "System Information screen (example)" is displayed.

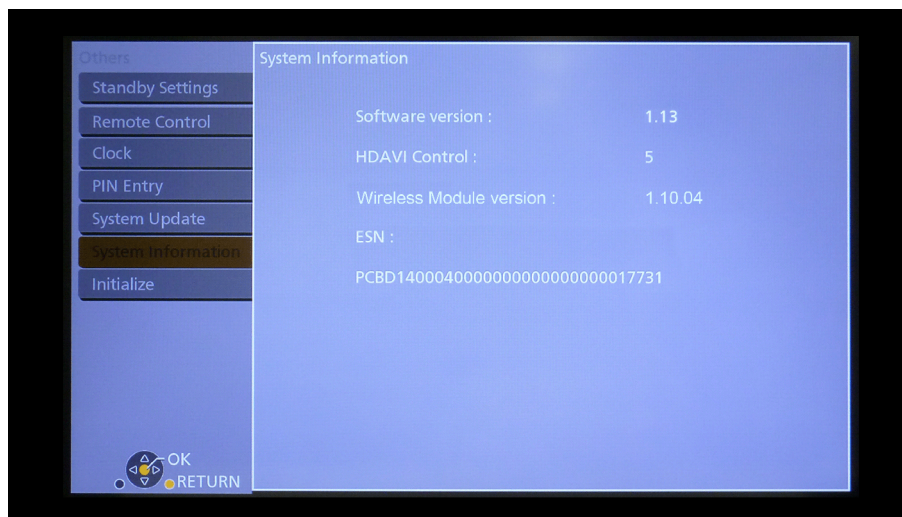

### 3.10.1.3. Confirm method of Wireless LAN Module invalidity/effective

1. Press [FUNCTION MENU].
2. Select "Setup" in "FUNCTION MENU", then press [OK].
3. Select "Basic Settings" in "Setup (Adjustment for Recorder functions.)", then press [OK].
4. Select "Display" in "Basic Settings", then press [OK].
5. Press [STATUS], more than 5 seconds. The following "Display screen (example)" is displayed.

In case of Wireless LAN Module effective.

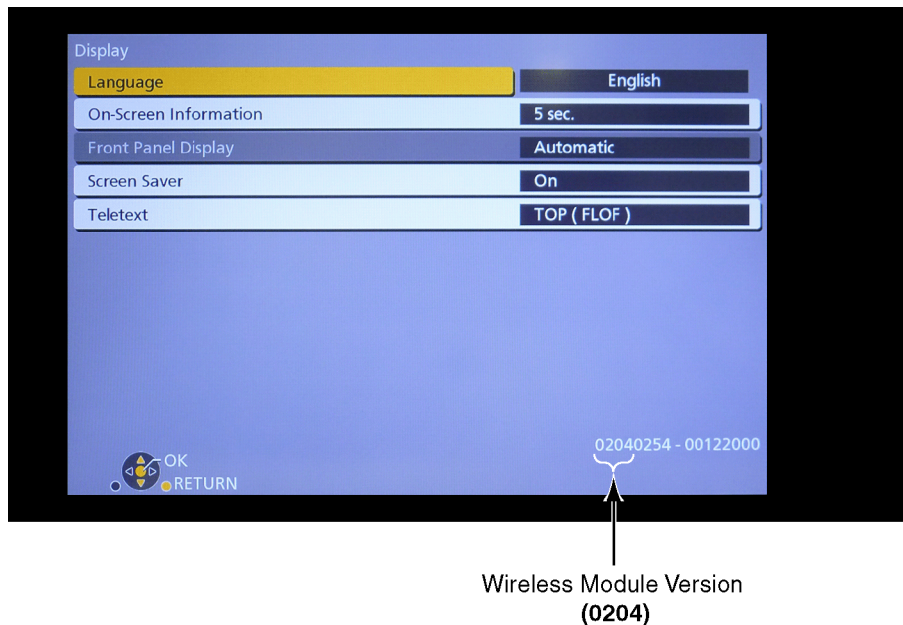

In case of Wireless LAN Module invalid.

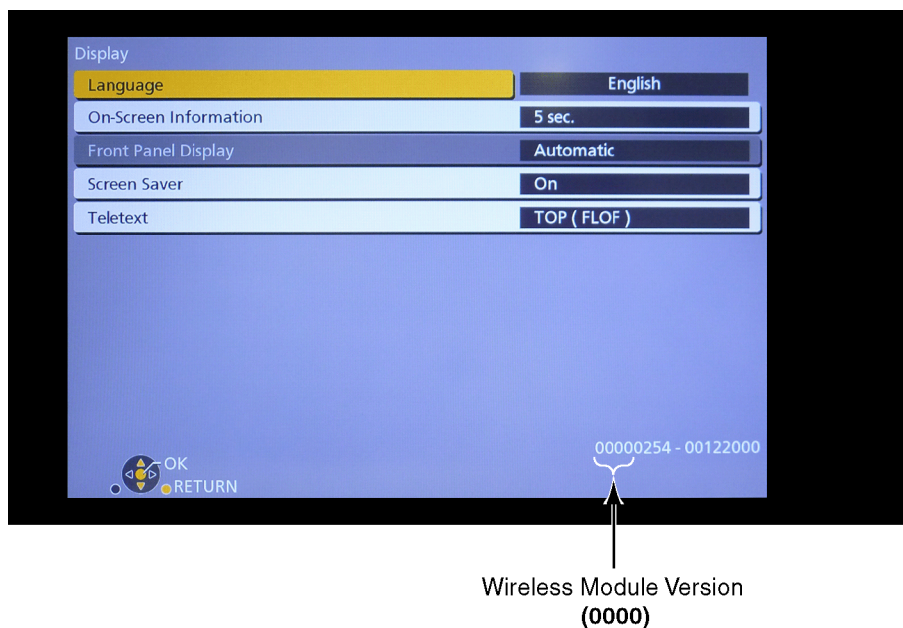

6. In case of Wireless LAN Module effective, Wireless LAN Module or Wireless LAN Module connection cable may be the source of problem.
7. Please finally check the operation of the fact.

### 3.11. Check with Tuner Service Mode

Inspect the inside components using the application for inspections by service personnel.

#### Main functions

N0	Function Name	Contents
01	Hard Test	Perform Access Test for each hard device and display the result.
02	User Setting Information Backup	Backup/ Restore User Setting Item (The Initial Setting) to the USB Memory.
03	Time xxxxxxxx Count yyyyyyy	Length of Power ON time/ Count of power ON time

#### 1. Execute Tuner Service Mode

- 1) Turn the power on to receive digital broadcasting (HD broadcasting).
- 2) Press the [5] [9] and [RED] button simultaneously for 5 seconds, then "70 RET" is displayed on FL.
- 3) Press the [▶] button to select until "82 TSR" is displayed on FL.
- 4) Press the [OK] button.
- 5) It is shown to have entered the tuner service mode.
- 6) The command is transmitted by attached remote control.

#### 2. Finishing Tuner Service Mode

Method 1: After turning the unit "OFF", pull out the AC cord.

Method 2: Repeat turning ON and OFF twice: P-OFF → P-ON → P-OFF → P-ON.

SRV-T00L	
Device TEST	
Backup Data to USB:	Restore Data from USB:
	Time 00000:00 Count 0000000

#### 3.11.1. Hard Test (Device Test)

Perform Access Test for each hard device and display the result.

SRV-T00L	
Device TEST	
Backup Data to USB:	Restore Data from USB:
	Time 00000:00 Count 0000000

```

+-----+
| -- Hard Test Result -- |
+-----+
| <1> EEPROM [READ] (Result) |
+-----+
| <2> EEPROM [WRITE] (Result) |
+-----+
| <3> TUNER 1 (Result) |
+-----+
| <4> TUNER 2 (Result) |
+-----+
| <5> LAN (Result) |
+-----+
| <6> TUNER 3 (Result) |
+-----+
| <7> ----- |
+-----+
| <8> ----- |
+-----+
| <9> ----- |
+-----+

```

<Function>

<1> : EEPROM [READ] : Read Test (Main P.C.B. : IC6811)  
 <2> : EEPROM [WRITE] : Write Test (Main P.C.B. : IC6811)  
 <3> : TUNER 1(DVB-S/S2 Tuner):I2C\_Bus Check (Digital P.C.B. :TU8000)  
 <4> : TUNER 2(DVB-S/S2 Tuner):I2C\_Bus Check (Digital P.C.B. :TU8000)  
 <5> : LAN:Register Access Test (Digital P.C.B. : IC59001)  
 <6> : TUNER 3(DVB-S/S2 Tuner):I2C\_Bus Check (Digital P.C.B. :TU8500 (DMR-UBS90EG))  
 <7> : (None)  
 <8> : (None)  
 <9> : (None)

<Display>

<1> : EEPROM [READ]   OK : Normality  
                           NG : EEPROM Read Error  
 <2> : EEPROM [WRITE]   OK : Normality  
                           NG : EEPROM Write Error  
 <3> : TUNER 1           OK : Normality  
                           NG : TUNER (DVB-S/S2 Tuner) I2C\_Bus. Error  
 <4> : TUNER 2           OK : Normality  
                           NG : TUNER (DVB-S/S2 Tuner) I2C\_Bus Error  
 <5> : LAN               OK : Normality  
                           NG : LAN Register Access Error  
 <6> : TUNER 3           OK : Normality (DMR-UBS90EG)  
                           NG : TUNER (DVB-S/S2 Tuner) IC2\_Bus Error (DMR-UBS90EG)

**Note:**

Hard test result does not guarantee that problems do not exist even if the result is OK.  
 The result is used as reference when any trouble occurs.

### 3.11.2. Use times and number of times of Power ON/OFF

Display accumulated time of Power ON and display number of times of Power ON/OFF.

SRV-TOOL	
Device TEST	
Backup Data to USB:	Restore Data from USB:
Time 00000:00(*1)Count 0000000(*2)	

- \*1 : Display accumulated time of Power ON  
 Display on a 15-minute basis  
 Example: 00123:15 → 123 hour 15 minute
- \*2 : Display number of times of Power ON/OFF  
 Example: 0000123 →123

### 3.11.3. User Setting Information Backup

#### Purpose

After the recorder is repaired, the restored setting information is not default, but the information before repaired.

#### Operation summary

Before starting repair, import the data on memory of the unit to export the data to USB Memory on Tuner Service Mode display. After the repair is finished, import the data on USB Memory to export the data to the memory on the unit by operating on Tuner Service Mode display again.

#### • Data to be backed up

Each setting item that a user can set at "SET UP" (\*1) and "DVB TUNING" (FUNCTION MENU → SETUP → BASIC SETTINGS → DVB TUNING) and "Program timer setting", "History information" etc.

- \* The following data cannot be backed up.
  - Program chart data
  - Dedicated areas for Internet site service providers (unique information for each company), broadcast mail, two-way communication list, board, or favorite page
  - Status saving systems (last channel except for VHF/UHF/CATV, drive selection status, etc.)  
etc.

#### Note:

Of user setting information, only items selected and set on the initial Setup display can be backed up and restored.

- \*1: Of user setting information, except items selected and set on the initial Setup display.

## Operation procedure

### Preparation:

Prepare a USB Memory to export data stored in this unit.

Create the following directory on the USB Memory.

¥EEPBAKUP

### Boot:

1. On Tuner Service Mode display  
Using Remote Control, move the cursor to user's setting information backup display position (Refer to below) on Tuner Service Mode display.
2. Press [OK].  
After "Try → OK" is displayed, the data is exported to USB Memory.  
(Refer to below)

SRV-TOOL	
Device TEST	
Backup Data to USB: OK	Restore Data from USB:
Time 00000:00    Count 0000000	

When OK(\*\*\*) is displayed, the data is successfully exported.

### Note:

If the backup file already exists in the USB Memory, the data is overwritten and "OK" is displayed.

3. Remove the USB Memory from the unit.
4. Turn the unit OFF to finish Tuner Service Mode.

## Restoring the backup data to the unit

1. Turn the unit ON.  
Perform the following: FUNCTION MENU → SETUP → BASIC SETTINGS → OTHERS → INITIALIZE → SHIPPING CONDITION
2. Start Tuner Service Mode.
3. Insert the USB Memory in save data to the unit.
4. Using Remote Control, move the cursor to user's setting information backup display position (Refer to below) on Tuner Service Mode display.

SRV-TOOL	
Device TEST	
Backup Data to USB: OK	Restore Data from USB:
Time 00000:00    Count 0000000	

5. Press [ENTER].  
After "Try → OK" is displayed, the data is restored to USB Memory.  
(Refer to below)

SRV-TOOL	
Device TEST	
Backup Data to USB: OK	Restore Data from USB: OK(***)
Time 00000:00    Count 0000000	

When OK(\*\*\*) is displayed, the data is successfully exported.

6. Remove the USB Memory from the unit.
7. Turn the unit OFF to finish Tuner Service Mode.

# 4 Specifications

General	
Power supply:	AC 220 - 240V 50Hz
Power consumption:	Approx. 68W (UBS90EG), Approx. 66W (UBS80EG)
Power consumption in networked standby mode:	"Quick Start" is not activated and "Networked Standby" is set to "On" Approx. 2 W
Power consumption in standby mode:	"Quick Start" is not activated and "Networked Standby" is set to "Off" Approx. 0.3 W
Operating temperature:	5°C - 40°C
Operating humidity range:	10% - 80% RH (no condensation)
Television system	
Tuner System:	DVB-S/S2
Antenna receive frequency	950MHz-2150MHz
Input impedance	Nominal 75 ohm
Demodulation	QPSK, 8PSK
LNB input	F shape terminal female, power supply 13V/18V max. 400mA
DiSEqC	Version 1.0 or Tone burst A/B, 22KHz 0.65Vp-p
Output terminal	
Digital audio out (coaxial):	1 pc.
HDMI terminal	
HDMI output (19 pin type A):	1 pc. (UBS80EG) 2 pcs. (UBS90EG) • This unit supports "HDAVI Control 5" function.
Internal HDD Capacity	
2TB (UBS90EG), 1TB (UBS80EG)	
Other terminals	
USB Port (Type A):	2 pcs USB 2.0 (High Speed) USB 3.0 (Super Speed)
SD Card Slot:	1 pc. (UBS90EG)
Common Interface slot:	2 pcs.
LAN (Ethernet) Port:	1 pc. 10BASE-T/100BASE-TX

Recording time				
Approx.				
Recording Mode	HDD (2TB) (UBS90EG)	HDD (1TB) (UBS80EG)	BD-RE, BD-R (SL, 25GB)	BD-RE, BD-R (SL, 50GB)
DVB-S (4KHEVC:28Mbps)	151 hours	75 hours	----- (*1)	----- (*1)
DR(*2)(HD:14Mbps) DR(*2)(SD: 5Mbps)	303 hours 847 hours	150 hours 422 hours	3h.30min. 10h.15min.	7h.30min. 21 hours
HG	315 hours	157 hours	4 hours	8 hours
HX	471 hours	235 hours	6 hours	12 hours
HE	707 hours	353 hours	9 hours	18 hours
HL	946 hours	472 hours	12 hours	24 hours
HM	1370 hours	684 hours	17h.30min.	35 hours
XP	431 hours	215 hours		
SP	863 hours	431 hours		
LP	1726 hours	862 hours		
Recording Mode	DVD-RAM		DVD-R DVD-RW (4.7GB)	DVD-R DL (8.5GB)
	4.7GB	9.4GB (Double Sided)		
DR(*2),HG,HX, HE,HL,HM				
XP	1 hour	2 hours	1 hour	1h.45min.
SP	2 hours	4 hours	2 hours	3h.35min.
LP	4 hours	8 hours	4 hours	7h.10min.
Recording Mode	+R +RW (4.7GB)	+R DL (8.5GB)		
DR(*2),HG,HX, HE,HL,HM				
XP	1 hour	1h.45min.		
SP	2 hours	3h.35min.		
LP	4 hours	7h.10min.		
*1: UHD programme cannot be copied to Blu-ray disc.				
*2: Recording time of DR mode may vary depending on bit rate of broadcasting.				
LASER specification				
Class 1 LASER Product				
Wave length:				
CD 783 nm wave length				
DVD 661 nm wave length				
BD 405 nm wave length				
Laser power: No hazardous radiation is emitted with the safety protection				

Regional Code											
DVD: #2 BD: Region B											
Playable discs											
<ul style="list-style-type: none"> <li>• BD-Video (Ultra HD Blu-ray, Blu-ray 3D, BD-Live)</li> <li>• BD-RE: Ver. 2.1, JPEG (*2), MPO (3D PHOTO (*2), AVCHD/AVCHD 3D (*2))</li> <li>• BD-RE DL: Ver. 2.1, JPEG (*2), MPO (3D PHOTO (*2), AVCHD/AVCHD 3D (*2))</li> <li>• BD-R: Ver. 1.3, LTH type Ver. 1.3, JPEG (*2), MPO (3D PHOTO (*2), AVCHD/AVCHD 3D (*2))</li> <li>• BD-R DL: Ver. 1.3, JPEG (*2), MPO (3D PHOTO (*2), AVCHD/AVCHD 3D (*2))</li> <li>• DVD-RAM: DVD Video Recording format, AVCHD format, JPEG (*4), MPO (3D PHOTO (*4))</li> <li>• DVD-R/R DL: DVD-Video format (*3), AVCHD format (*3), JPEG (*4), MPO (3D PHOTO (*4)), MP3 (*4), MKV (*4), WAV (*4), FLAC (*4), AAC (*4), WMA (*4), DSD (*4), ALAC (*4)</li> <li>• DVD-RW: DVD-Video format (*3), DVD-Video Recording format, AVCHD format (*3)</li> <li>• +R/+R DL: Video (*3), AVCHD format (*3), JPEG(*4), MPO (3D PHOTO (*4)), MP3 (*4), MKV (*4), WAV (*4), FLAC (*4), AAC (*4), WMA (*4), DSD (*4), ALAC (*4)</li> <li>• +RW: Video (*3), AVCHD format (*3)</li> <li>• DVD-Video: DVD-Video format</li> <li>• CD-Audio: CD-DA</li> <li>• CD-R/CD-RW: CD-DA, JPEG (*4), MPO (3D PHOTO (*4)), MP3 (*4), MKV (*4), WAV (*4), FLAC (*4), AAC (*4), WMA (*4), ALAC (*4)</li> </ul>											
*2: BD disc needs to be based on UDF format. *3: Finalizing is necessary. *4: DVD/CD disc need to be based on UDF or ISO9660 format.											
Recording System											
<ul style="list-style-type: none"> <li>• BD-RE (SL/DL): Blu-ray Disc Rewritable format</li> <li>• BD-R (SL/DL): Blu-ray Disc Recordable format</li> <li>• DVD-RAM: DVD-Video Recording format</li> <li>• DVD-R (SL/DL): DVD-Video format, AVCHD format</li> <li>• DVD-RW: DVD-Video format</li> <li>• +R (SL/DL), +RW: DVD-Video format</li> </ul>											
SD Card (UBS90EG)											
<ul style="list-style-type: none"> <li>• SD Card Slot: SD Memory Card slot; 1 pc</li> <li>• Compatible media: SD Memory Card (*5)</li> <li>• Format: FAT12, FAT16, FAT32 (*6), exFAT (*7)</li> <li>• Data that can be played: JPEG, MPO, AVCHD format, MP4</li> </ul>											
*5: Includes SDHC/SDXC Card. Includes miniSD™ Cards (need a miniSD™ Adaptor). Includes microSD™/microSDHC™/microSDXC™ Cards (need a microSD™ Adaptor). *6: Not support long file name *7: SDXC only											
USB device											
<ul style="list-style-type: none"> <li>• USB standard: USB 2.0 High Speed USB 3.0 Super Speed</li> <li>• Format: FAT12, FAT16, FAT32, NTFS</li> <li>• Data that can be played: MP3, JPEG, MPO (3D PHOTO), MKV, MP4, MPEG-2, AVCHD/AVCHD 3D, WAV, FLAC, AAC, WMA, DSD, ALAC</li> </ul>											
Broadcast Recordings											
Numbers of titles that can be recorded:											
<table border="1"> <thead> <tr> <th>Media</th> <th>Maximum titles</th> </tr> </thead> <tbody> <tr> <td>HDD</td> <td>3000</td> </tr> <tr> <td>BD-RE, BD-R</td> <td>200</td> </tr> <tr> <td>DVD-RAM, DVD-R, DVD-RW</td> <td>99</td> </tr> <tr> <td>+R, +RW</td> <td>49</td> </tr> </tbody> </table>		Media	Maximum titles	HDD	3000	BD-RE, BD-R	200	DVD-RAM, DVD-R, DVD-RW	99	+R, +RW	49
Media	Maximum titles										
HDD	3000										
BD-RE, BD-R	200										
DVD-RAM, DVD-R, DVD-RW	99										
+R, +RW	49										
• Maximum numbers of titles are including recordings of HDD CAMCODER.											

HDD CAMCODER Recordings											
MPEG-4 AVC/H.264 (based on AVCHD)											
Numbers of titles that can be recorded:											
<table border="1"> <thead> <tr> <th>Media</th> <th colspan="2">Maximum titles</th> </tr> </thead> <tbody> <tr> <td>HDD</td> <td colspan="2">3000</td> </tr> <tr> <td>BD-RE, BD-R</td> <td colspan="2">200</td> </tr> </tbody> </table>			Media	Maximum titles		HDD	3000		BD-RE, BD-R	200	
Media	Maximum titles										
HDD	3000										
BD-RE, BD-R	200										
• Maximum numbers of titles are including recordings of Broadcast.											
Photo Files											
JPEG based on DCF (Design rule for Camera File system)											
MPO based on MPF (Multi Picture Format)											
Compatible pixels: Between 34×34 and 8192×8192 pixels											
Sub Sampling: 4:2:2, 4:2:0 (Motion JPEG not supported.)											
Maximum numbers of contents:											
<table border="1"> <thead> <tr> <th>Media</th> <th>Folders</th> <th>Files</th> </tr> </thead> <tbody> <tr> <td>HDD</td> <td>-</td> <td>20000</td> </tr> <tr> <td>BD-RE, BD-R, DVD-RAM, DVD-R, +R, CD-R, CD-RW, USB device, SD card</td> <td>500</td> <td>10000</td> </tr> </tbody> </table>			Media	Folders	Files	HDD	-	20000	BD-RE, BD-R, DVD-RAM, DVD-R, +R, CD-R, CD-RW, USB device, SD card	500	10000
Media	Folders	Files									
HDD	-	20000									
BD-RE, BD-R, DVD-RAM, DVD-R, +R, CD-R, CD-RW, USB device, SD card	500	10000									
Video Files, Audio Files											
Support codec of Video: MKV, MP4 (4K/24p, 25p and 30p (*8)), MPEG2 (TS/PS) (*9)											
Support codec of Audio: MP3, WAV, FLAC, AAC (M4A), WMA, DSD, ALAC (*9)											
Numbers of contents that can be copied to internal HDD:											
<table border="1"> <thead> <tr> <th>Contents</th> <th>Maximum numbers of folders and files</th> </tr> </thead> <tbody> <tr> <td>Video contents</td> <td>20000</td> </tr> <tr> <td>Audio contents</td> <td>20000</td> </tr> </tbody> </table>			Contents	Maximum numbers of folders and files	Video contents	20000	Audio contents	20000			
Contents	Maximum numbers of folders and files										
Video contents	20000										
Audio contents	20000										
USB device: Each folder can store up to 1000 files. *8: Bit rate up to 100Mbps/resolution up to 3840 × 2160 25p/30p, 4096 × 2160 24p. *9: Supported codec depend on media type.											
Wireless LAN											
Standard compliance:	IEEE802.11n / IEEE802.11g / IEEE802.11b / IEEE802.11a										
Frequency Range:	2.4 GHz / 5 GHz band										
Security (*10):	WPA2™-PSK (TKIP/AES) / WPA™-PSK (TKIP/AES) / WEP (64bit/128bit)										
*10: This unit supports WPA and WPA2 encryption.											
Dimensions											
DMR-UBS80EG: 430 mm (W) × 62 mm (H) × 201 mm (D) (excluding the projecting parts) 430 mm (W) × 62 mm (H) × 210 mm (D) (including the projecting parts)											
DMR-UBS90EG: 430 mm (W) × 68 mm (H) × 201 mm (D) (excluding the projecting parts) 430 mm (W) × 68 mm (H) × 210 mm (D) (including the projecting parts)											
Mass											
Approx. 3.2 kg (UBS80EG) Approx. 3.3 kg (UBS90EG)											
Solder											
These models use lead free solder (PbF)											

**Note:**  
Specifications are subject to change without notice.

# 5 Location of Controls and Components

Followings are the Location of Controls and Components for DMR-UBS90EG as a sample. For other models, refer to each Operating Instructions.

## Main unit

Front

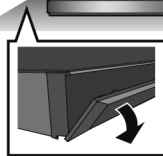
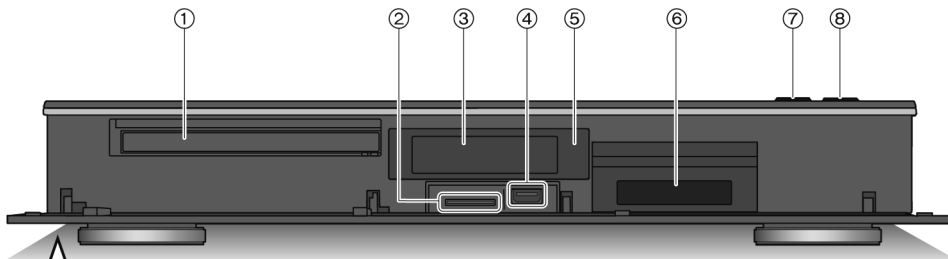

Pull to flip down the front panel.

- ① Disc tray
- ② SD card slot (UBS90)
- ③ Display
- ④ USB port (DC 5 V 900 mA)
  - This port supports USB 3.0 Super Speed.
- ⑤ Remote control signal sensor
  - Angle: Approx. 20° up and down, 30° left and right
  - Distance: Within approx. 7 m in front of the unit
- ⑥ CI slot
- ⑦ Open/close disc tray
- ⑧ **Standby/on switch (⏻/⏻)**  
Press to switch the unit from on to standby mode or vice versa. In standby mode, the unit is still consuming a small amount of power.

### ■ SD card/USB device

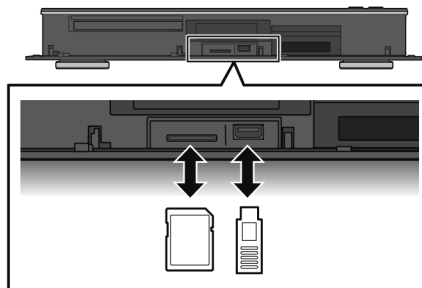

- While writing to/reading from the media, do not switch the unit to standby mode or remove the media. Such action may result in loss of the media contents.
- When inserting the media, ensure that it is facing the right way up.
- When removing the SD card, press on the centre of the card and pull it straight out.
- The USB port on the front side does not support USB HDDs. Connect a USB HDD to the USB port on the rear side. (Connecting the USB HDD)

### Inserting or removing media

#### ■ Disc

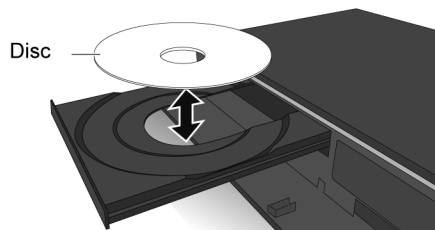

## Display

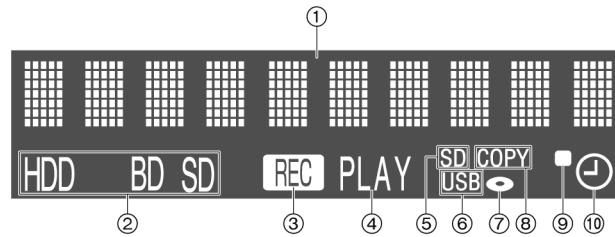

- |  |   |
|--|---|
| <ul style="list-style-type: none"> <li>① Main display section indicator                     <ul style="list-style-type: none"> <li>• Messages and other information are displayed.</li> </ul> </li> <li>② Drive (HDD, BD or SD) indicator</li> <li>③ Recording indicator                     <ul style="list-style-type: none"> <li>• The indicator will light up while recording.</li> <li>• The indicator will blink while recording is paused and before recording starts.</li> </ul> </li> <li>④ Playback indicator</li> <li>⑤ SD card slot indicator</li> </ul> | <ul style="list-style-type: none"> <li>⑥ USB port indicator</li> <li>⑦ Disc indicator</li> <li>⑧ Copying indicator</li> <li>⑨ Remote control signal indicator</li> <li>⑩ Timer recording indicator                     <ul style="list-style-type: none"> <li>This indicator lights up when the timer recording standby or Keyword Recording standby is activated.</li> </ul> </li> </ul> |
|--|---|

## Rear

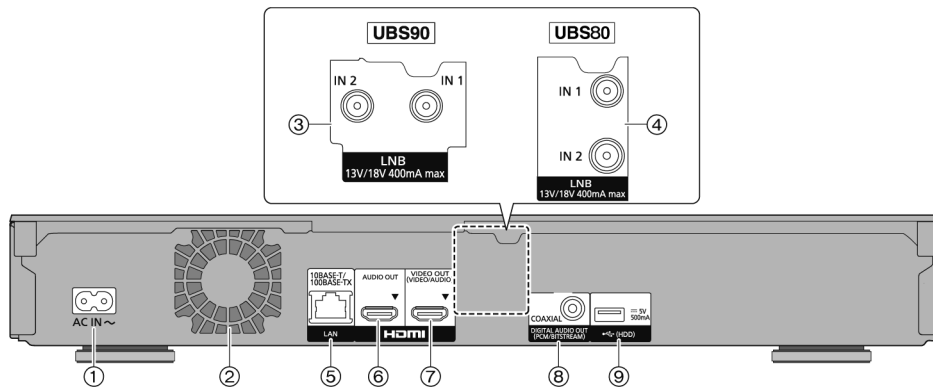

- |   |  |
|---|--|
| <ul style="list-style-type: none"> <li>① AC IN terminal ( ~ )</li> <li>② Cooling fan</li> <li>③ LNB IN 1/2 terminal (UBS90)</li> <li>④ LNB IN 1/2 terminal (UBS80)</li> <li>⑤ LAN port</li> <li>⑥ HDMI AUDIO OUT terminal (UBS90)</li> <li>⑦ HDMI VIDEO OUT terminal (UBS90)</li> <li>⑦ HDMI AV OUT terminal (UBS80)</li> </ul> | <ul style="list-style-type: none"> <li>⑧ COAXIAL terminal</li> <li>⑨ USB port ( DC 5 V 500 mA )                     <ul style="list-style-type: none"> <li>• This port supports USB 2.0 High Speed.</li> <li>• Connect a USB HDD to this USB port.</li> </ul> </li> </ul> <p>☐ Class II equipment (The construction of the product is double-insulated.)</p> |
|---|--|

# Remote Control

Instructions for operations are generally described using the remote control.

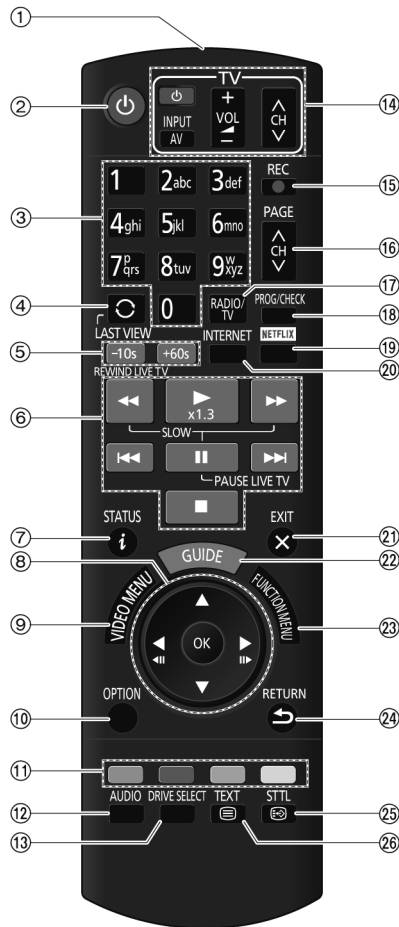

- ① Transmit the remote control signal
  - Point it at remote control signal sensor on this unit.
- ② Switch the unit from on to standby mode or vice versa
- ③ Select channels and programme numbers, etc./Enter numbers or characters
- ④ Switch to the previously watched channel
- ⑤ Manual skip
  - 10s: Skip approx. 10 seconds backward
  - +60s: Skip approx. 1 minute forward
- ⑥ Basic operations for recording and play, REWIND LIVE TV/PAUSE LIVE TV
- ⑦ Show Information
- ⑧ Selection/OK, Frame-by-frame
- ⑨ Show Video Menu, Top Menu, Pop-up Menu
- ⑩ Show OPTION menu
- ⑪ Colour buttons (red, green, yellow, blue) (Use in accordance with instruction on the screen.)
- ⑫ Select audio
- ⑬ Select drive (HDD, Disc, SD or USB)
- ⑭ TV operation buttons
- ⑮ Start recording
- ⑯ Channel select/Change pages in the Video Menu screen etc.
- ⑰ Switching to the radio channel list
- ⑱ Show the Timer Recording screen
- ⑲ Show NETFLIX screen
- ⑳ Show the Network Service screen
- ㉑ Exit the menu screen
- ㉒ Show the TV Guide screen
- ㉓ Show the FUNCTION MENU screen
- ㉔ Return to previous screen
- ㉕ Show subtitles
- ㉖ Show Teletext

# 6 Installation Instructions

**Note:**

In this document, explanations basically use illustrations of DMR-UBS90EG.  
In other models, shape of some parts may be different.

## 6.1. Taking out the Disc from BD Drive Unit when the Disc cannot be ejected by OPEN/CLOSE button

### 6.1.1. Forcible Disc Eject

#### 6.1.1.1. When the power can be turned off.

1. Turn off the power, press and hold [OK], [BLUE] and [YELLOW] on the remote control at the same time for more than 5 seconds. -"00 RET" is displayed on the unit's display.
2. Repeatedly press [▶] on the remote control or [POWER] on the unit until "06 FTO" is displayed on the unit's display.
3. Press [OK] on the remote control or [OPEN/CLOSE] on the unit.

#### 6.1.1.2. When the power can not be turned off.

1. Press [POWER] key on the front panel for over 4 seconds to turn off the power forcibly, press and hold [OK], [BLUE] and [YELLOW] on the remote control at the same time for more than 5 seconds. -"00 RET" is displayed on the unit's display.
2. Repeatedly press [▶] on the remote control or [POWER] on the unit until "06 FTO" is displayed on the unit's display.
3. Press [OK] on the remote control or [OPEN/CLOSE] on the unit.

#### 6.1.2. When the Forcible Disc Eject can not be done.

1. Turn off the power and pull out AC cord.
2. Put deck so that bottom can be seen.
3. Slide SLIDE CAM by Paper Clip or minus screw driver (small) in the direction of arrow to eject tray slightly.

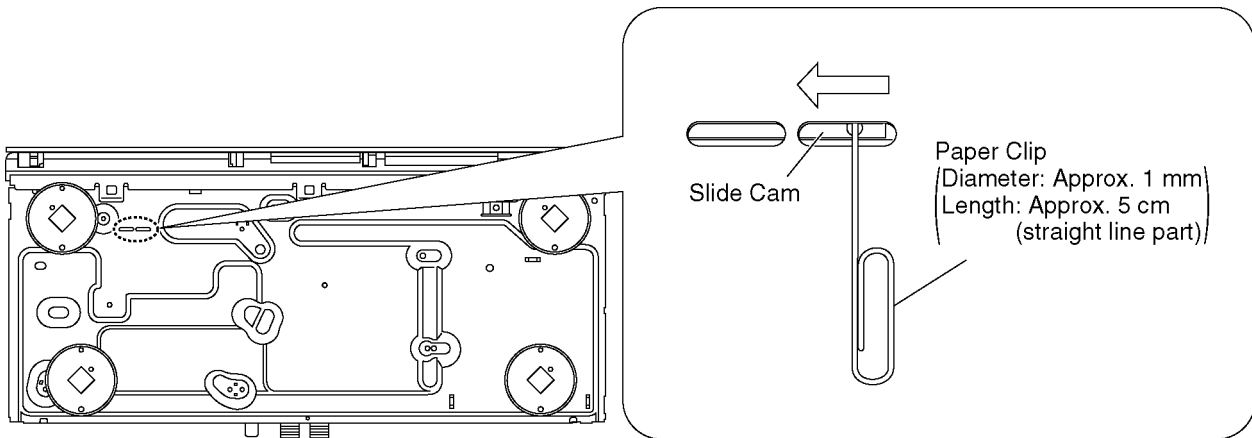

4. Put deck upward, and pick out Tray by finger.

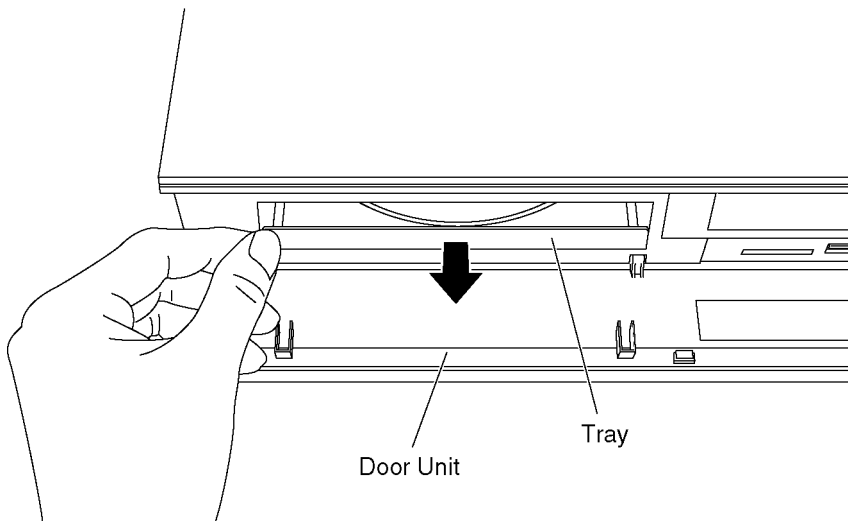

# 7 Service Mode

## 7.1. Self-Diagnosis and Special Mode Setting

### 7.1.1. Self-Diagnosis Functions

Self-Diagnosis Function provides information for errors to service personnel by "Self-Diagnosis Display" when any error has occurred.

**U\*\***, **H\*\*** and **F\*\*** are stored in memory and held.

You can check latest error code by transmitting [0] [1] of Remote Control in Service Mode.

Automatic Display on FL will be cancelled when the power is turned off or AC input is turned off during self-diagnosis display is ON.

Remote Control:

[R] = [RED]

[Y] = [YELLOW]









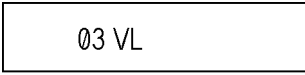

[B] = [BLUE]

Error Code	Diagnosis contents	Description	Monitor Display	Automatic FL display
U50	Short circuit for Antenna (LNBIN 1 and LNB IN 2) is detected	The terminal, antenna cable or dish is short-circuit as for both LNB IN 1 and LNB IN 2. Check the connection status.	No display	U50
U50 1	Short circuit for Antenna (LNBIN 1) is detected	The terminal, antenna cable or dish is short-circuit as for LNB IN 1. Check the connection status.	No display	U50 1
U50 2	Short circuit for Antenna (LNBIN 2) is detected	The terminal, antenna cable or dish is short-circuit as for LNB IN 2. Check the connection status.	No display	U50 2
U59	Abnormal inner temperature detected	Display appears when internal temperature of deck reaches limit temperature. The power is turned off forcibly. For 30 minutes after this, all key entries are disabled. (Fan motor operates at the highest speed for the first 5 minutes. For the remaining 25 minutes, fan motor is also stopped.) The event is saved in memory as well.	No display	U59 U59 is displayed for 30 minutes.
U61	The unit is carrying out its recovery process. ( <u>with no disc in the disc tray</u> )	<ul style="list-style-type: none"> <li>The unit detected an error while recording or playing <u>with no disc in the disc tray</u>. The unit is carrying out its recovery process. This process restores the unit to normal operation. The unit is not broken. Wait until the message disappears.</li> </ul>	No display	U61
U71	HDMI incompatible error (HDCP incompatible)	Display this error when the equipment (compatible with DVI such as TV, amplifier etc.) connected to the unit by HDMI is incompatible with HDCP. *HDCP=High-bandwidth Digital Content Protection	No display	U71
U72	HDMI connection error (communication error)	This error is displayed when there are any communication problems with the unit and the equipments (TV, amplifier etc.) connected to the unit by HDMI. (or when there is a problem with the HDMI cable)	No display	U72 U72 display disappears when error has been solved by Power OFF/ON of connecting equipment or by inserting/removing of HDMI cable.
U73	HDMI connection error (authentication error)	When authentication error occurs while the equipments (TV, amplifier etc.) are connected by HDMI. (or when there is a problem with the HDMI cable)	No display	U73 U73 display disappears when error has been solved by Power OFF/ON of connecting equipment or by inserting/removing of HDMI cable.

Error Code	Diagnosis contents	Description	Monitor Display	Automatic FL display
U76	HDMI connection error	HDMI cannot be output because you are connected to a model that does not support copyright protection.	No display	U76
U77	Illegal disc error	Due to the current disc not having authorized copyright information, video output is not performed.	No display	U77
U88	The unit is carrying out its recovery process. (with a disc in the disc tray)	<ul style="list-style-type: none"> <li>The unit detected an error while recording or playing <u>with a disc in the disc tray</u>. The unit is carrying out its recovery process. This process restores the unit to normal operation. The unit is not broken.</li> <li>Wait until the message disappears.</li> </ul>	No display	U88
U99	Hang-up	Displayed when communication error has occurred between Main microprocessor and Timer microprocessor.	No display	U99
H19 02	Inoperative fan motor	When inoperative fan motor is detected after powered on, the power is turned off automatically. The event is saved in memory.	No display	No display
F00	No error information	Initial setting for error code in memory (Error code Initialization is possible with error code initialization and main unit initialization.)	No display	No display
F34	Initialization error when main microprocessor is started up for program recording	When initialization error is detected after starting up main microprocessor for program recording, the power is turned off automatically. The event is saved in memory.	No display	No display
F58	Drive hardware error	When drive unit error is detected, the event is saved in memory.	No display	No display
F74	HDMI Device Key Communication error.	HDMI connection could not be authenticated due to a transfer malfunction. Factor of HDMI Device key-road failure <ul style="list-style-type: none"> <li>When HDMI LSI is damaged.</li> <li>When the bus line of I2C doesn't operate normally.</li> <li>When device key information recorded is damaged.</li> </ul>	No display	F74
F75	HDMI Device Key Information error	HDMI connection could not be authenticated due to an internal data malfunction. Factor of HDMI Device key-road failure <ul style="list-style-type: none"> <li>When HDMI LSI is damaged.</li> <li>When the bus line of I2C doesn't operate normally.</li> <li>When device key information recorded is damaged.</li> </ul>	No display	F75
SET CODE *	Remote control code error	Display appears when main unit and remote controller codes are not matched.	No display	SET CODE *
UNSUPPORT	Unsupported disc error	<ul style="list-style-type: none"> <li>*An unsupported format disc was played, although the drive starts normally.</li> <li>*The data format is not supported, although the media type is supported.</li> <li>*Exceptionally in case of the disc is dirty.</li> </ul>	<b>"This disc is incompatible."</b>	Display for 5 seconds. <div style="text-align: center;">UNSUPPORT</div>
NO READ	Disc read error	<ul style="list-style-type: none"> <li>*A disc is flawed or dirty.</li> <li>*A poor quality failed to start.</li> <li>*The track information could not be read.</li> </ul>	<b>"Cannot read. Please check the disc."</b>	NO READ

Error Code	Diagnosis contents	Description	Monitor Display	Automatic FL display
HARD ERROR	Drive error	The drive detected a hard error.	"BD drive error."	Display for 5 seconds. <div style="border: 1px solid black; padding: 5px; text-align: center;">HARD ERROR</div>
SELF CHECK	Restoration operation	Since the power cord fell out during a power failure or operation, it is under restoration operation. *It will OK, if a display disappears automatically. If a display does not disappear, there is the possibility that defective Digital P.C.B. / BD drive.	No display	<div style="border: 1px solid black; padding: 5px; text-align: center;">SELF CHECK</div>
PLEASE WAIT	Unit is in termination process	Unit is in termination process now. "Good bye" is displayed and power will be turned off. In case "Quick Start" of setup menu is ON, it is displayed in restoration operation for AC off.	No display	<div style="border: 1px solid black; padding: 5px; text-align: center;">PLEASE WAIT.</div> The character indication flows sideways.
UNFORMAT	Unformatted disc error	You have inserted an unformatted BD-RE, BD-R, DVD-RAM or DVD-RW that is unformatted or recorded on other equipment.	<div style="border: 1px solid black; padding: 2px; text-align: center;">Format</div> This disc is not formatted properly. Format the disc in DISK MANAGEMENT?	<div style="border: 1px solid black; padding: 5px; text-align: center;">UNFORMAT</div>
IR ERR	IR communication error	[IR ERR] is displayed when communication between Timer microprocessor and IR microprocessor fails.	No display	<div style="border: 1px solid black; padding: 5px; text-align: center;">IR_ERR</div>
No REC	Recording is impossible	[No REC] is displayed when recording is impossible due to the defect, dirt or wound of media.	No display	<div style="border: 1px solid black; padding: 5px; text-align: center;">NO REC</div>
HDD ERROR	[HDD ERR] is displayed when start up of HDD was failed. (Except error of setting of Power on Stand-by)	a) When normal start up was failed. b) When start up at HDD boot was failed. c) When start up from state of P-OFF was failed. d) When start up from state of HDD SLEEP was failed. [HDD ERR] is displayed when above each start up of HDD was failed. *In case b), tray opens automatically and [HDDERR] is displayed until version up disc is inserted.	No display	<div style="border: 1px solid black; padding: 5px; text-align: center;">HDDERR</div>
HDD NG	Power on Stand-by setting error	[HDD NG] is displayed when power on Stand-by setting of HDD is NG or when HDD which power on Stand-by is not set to is used. Please try to replace HDD with genuine HDD as service parts.	No display	<div style="border: 1px solid black; padding: 5px; text-align: center;">HDD NG</div>
No ERASE	Erase is impossible	You cannot delete items on this disc. The disc may be damaged. Use a new disc.	No display	<div style="border: 1px solid black; padding: 5px; text-align: center;">NO ERASE</div>
No WRITE	Writing is impossible	You cannot write to this disc. The disc may be damaged. Use a new disc.	No display	<div style="border: 1px solid black; padding: 5px; text-align: center;">NO WRITE</div>
PROGRAMME FULL	Timer programmes are full	There are already 32 timer programmes. Delete unnecessary timer programmes.	No display	<div style="border: 1px solid black; padding: 5px; text-align: center;">PROGRAMME FULL</div> The character indication flows sideways.

## 7.1.2. Special Modes Setting

Item		FL display	Key operation
Mode name	Description		Front Key
Rating password	The audiovisual level setting password is initialized to Level 8.	1.  2.  3. 	1. While the unit is on, press and hold [OK], [B] and [Y] on the remote control at the same time for more than 5 seconds. - "00 RET" is displayed on the unit's display. 2. Repeatedly press [▶] on the remote control or [POWER] on the unit until "03 VL" is displayed on the unit's display. 3. Press [OK] on the remote control or [OPEN/CLOSE] on the unit.
Service Mode	Setting every kind of modes for servicing. *Details are described in "7.1.3. Service Mode at a glance".	2.  3.  4. 	1. Turn the power off. 2. Press the [5] [9] and [R] button simultaneously for 5 seconds, then "70 RET" is displayed on FL. 3. Press the [▶] button to select until "80 SRV" is displayed on FL. 4. Press the [OK] button. *The command is transmitted by attached remote control.
BD-ROM history cleaning	"Persistent Storage" of BD-ROM standard is cleaned. Screen display: [The player's history data has been cleared.] is displayed for 5 seconds.	1.  2.  3. 	1. When the power is on, disc is not in tray, press and hold [6], [7] and [Y] on the remote control at the same time for more than 5 seconds. - "50 RET" is displayed on the unit's display. 2. Repeatedly press [▶] on the remote control or [POWER] on the unit until "51 NOP" is displayed on the unit's display. 3. Press and hold [STOP] on the remote control until "52 BRE" is displayed on the unit's display. 4. Press [OK] on the remote control or [OPEN/CLOSE] on the unit.
Forced disc eject	Removing a disc that cannot be ejected. The tray will open and unit will shift to P-off mode. While Demonstration Lock is being set, this Forced disc eject function is not accepted.	1.  2. 	1. While the unit is off, press and hold [OK], [B] and [Y] on the remote control at the same time for more than 5 seconds. - "00 RET" is displayed on the unit's display. 2. Repeatedly press [▶] on the remote control or [POWER] on the unit until "06 FTO" is displayed on the unit's display. 3. Press [OK] on the remote control or [OPEN/CLOSE] on the unit.
Forced power-off	When the power button is not effective while power is ON, turn off the power forcibly. *When Timer REC is ON or EXT-LINK is ON, execute "Forced Power-off" after releasing Timer REC or EXT-LINK.	Display in P-off mode.	Press [Power] key more than 4 seconds.

Item		FL display	Key operation
Mode name	Description		Front Key
Child lock/unlock	Set or release "Child Lock".	<div style="border: 1px solid black; padding: 5px; width: fit-content; margin: 0 auto;">X HOLD</div>	Press and hold [OK] and [RETURN] by remote control simultaneously until "X HOLD" is displayed/ disappeared.
Aging	Perform sequence of modes as * Aging Description shown below continually.  <div style="border: 1px solid black; padding: 5px;"> <b>Caution:</b>  <b>All programs in HDD and BD-RE disc will be deleted because Formatting is done once in Aging process.</b> </div>	Display the following mode.	1. Turn the power ON 2. Press the [5] [9] and [R] button simultaneously for 5 seconds, then "70 RET" is displayed on FL. 3. Press the [▶] button to select until "81 AIG" is displayed on FL. 4. Press the [OK] button. *The command is transmitted by attached remote control. <b>Note1:</b> if the unit has hung-up because of pressing keys for over 10 seconds, once turn off the power, and re-execute this command. *When releasing Aging mode, press [POWER] key over 4 seconds.

## Aging

### Overview

- Record several programs onto the mounted HDD with DR mode until the recording capacity becomes full. Then play back all the recorded programs (including special playback).
- When the remaining capacity becomes almost zero due to multiple recordings, the disc is formatted, recording is made onto the same disc again and playback starts.
- Direct recording to BD-RE (V2.0) media is not possible. So firstly record 1 program with 1-hour length onto HDD with DR mode, and then record onto BD-RE (V2.0) with FR mode.
- By performing reencode copying, almost entire BD-RE (V2.0) capacity is consumed to copy and record.

### Restrictions and Notes:

1. Confirm that ATP can receive CH009 and CH090.
2. Insert a recordable BD-RE (V2.0) media into the BD drive.
3. Set the initial setting of HDD/BD drive to HDD.
4. Turn the power ON to play the BD recorder and press STOP to receive broadcasting.
5. REC Mode : HL

### Flow chart for Aging Sequence

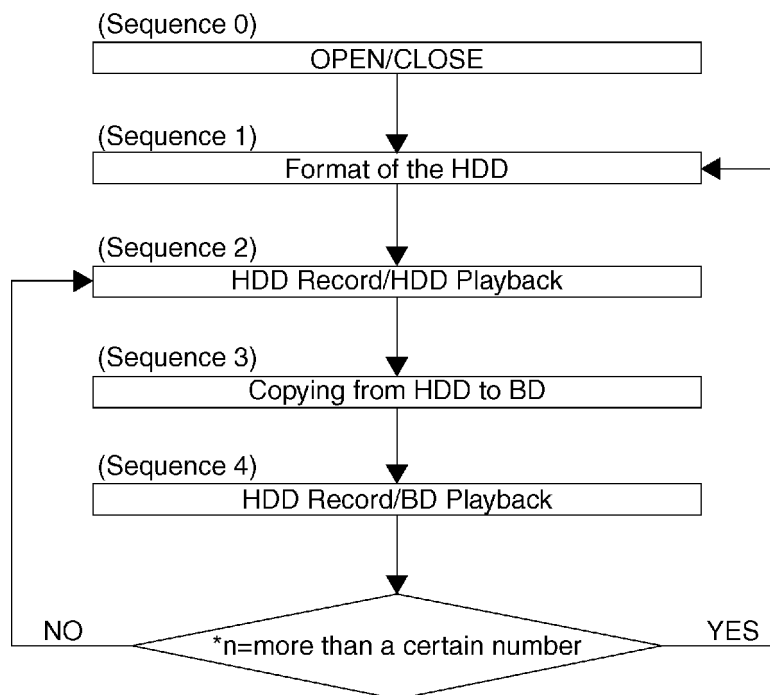

\*Judge based on the times of repetitive recordings

**Sequence 0: OPEN/CLOSE of BD drive tray**

Press [OPEN/CLOSE] to open the tray, then inserting discs.  
 Press [OPEN/CLOSE] to close the tray.

「Open the tray.」 → 「Close the tray.」

**Sequence 1: Format of the HDD**

「Select the HDD drive.」 → 「Display the function menu screen.」 → 「The setting program is executed.」 → 「The HDD format is executed.」  
 → 「Display the format complete picture of HDD format.」 → 「Erase the HDD management picture, then display the EE picture.」

**Sequence 2: Details of Record/ Playback**

HDD: Record/ HDD: Playback

「Select the 009 CH.」 → 「Start the [RECORD 1]. (REC Mode: LH)」 → 「Select the 090 CH.」 →  
 「Start the [RECORD 2]. (REC Mode (Auto): DR)」 → 「Playback the [PLAYBACK 2 (090 CH)].」 → 「Playback by [Fast Rewind].」 →  
 「Playback by [Fast Forward].」 → 「Playback by [Playback X 1].」 → 「To pause from playing.」 → 「Slow playback (Forward).」 →  
 「The setting program is executed.」 → 「Open the tray.」 → 「Close the tray.」 → 「Erase the guide screen. (BD)」 →  
 「Switch the drive from BD drive to HDD.」

**Sequence 3: Detail of copying. (HDD to BD)**

Recorded to the BD.

「Playback the program at the time of the EE screen.」 → 「The setting program is executed.」 →  
 「Copying Start. (After copy ends, the returns to EE screen.)」

**Sequence 4: Record/ Playback**

HDD: Record/ BD: Playback

「Start the recording. (Signal: 090 CH, REC Mode: HL)」 → 「Start the [RECORD 2]. (REC Mode (Auto): DR)」 →  
 「Switch the drive from HDD to BD drive.」 → 「Erase the guide screen.」 → 「Start playback the BD disc.」 →  
 「Playback by [Fast Forward].」 → 「Playback by [Fast Rewind].」 → 「Playback by [Playback X 1].」 → 「To pause from playing.」 →  
 「Slow playback (Forward)」 → 「Slow playback (Rewind)」 → 「The setting program is executed.」 →  
 「Switch the drive from BD to HDD drive. (Stop the BD playing.)」 → 「Start the playing. (HDD)」 →  
 「Playback by [Fast Rewind].」 → 「Playback by [Fast Forward].」 → 「Playback by [Playback X 1].」 → 「To pause from playing.」 →  
 「Slow playback (Forward).」 → 「The setting program is executed.」 → 「Stop the [RECORD 2 (090 CH)].」 →  
 「Stop the [RECORD 1 (009 CH)].」 → 「Erase the simple OSD screen and detail OSD screen.」

**Number of repetition:**

HDD Capacity	Number of repetition
2TB (UBS90EG)	200
1TB (UBS80EG)	100

Item		FL display	Key operation
Mode name	Description		Front Key
Demonstration lock/ unlock	Ejection of the disc is prohibited. The lock setting is effective until unlocking the tray and not released by "Main unit initialization" of service mode.	*When lock the tray. 1. <div style="border: 1px solid black; padding: 5px; width: fit-content; margin: 5px auto;">00 RET</div> 2. <div style="border: 1px solid black; padding: 5px; width: fit-content; margin: 5px auto;">04 PRG</div> 3. <div style="border: 1px solid black; padding: 5px; width: fit-content; margin: 5px auto;">10 OCL</div> 4. <div style="border: 1px solid black; padding: 5px; width: fit-content; margin: 5px auto;">LOCK</div> "LOCK" is displayed for 3 seconds.	1. While the unit is on, press and hold [OK], [B] and [Y] on the remote control at the same time for more than 5 seconds. - "00 RET" is displayed on the unit's display. 2. Repeatedly press [▶] on the remote control or [POWER] on the unit until "04 PRG" is displayed on the unit's display. 3. Press and hold [STOP] on the remote control until "10 OCL" is displayed on the unit's display. 4. Press [OK] on the remote control or [OPEN/CLOSE] on the unit.
		*When unlock the tray. 1. <div style="border: 1px solid black; padding: 5px; width: fit-content; margin: 5px auto;">00 RET</div> 2. <div style="border: 1px solid black; padding: 5px; width: fit-content; margin: 5px auto;">04 PRG</div> 3. <div style="border: 1px solid black; padding: 5px; width: fit-content; margin: 5px auto;">10 OCL</div> 4. <div style="border: 1px solid black; padding: 5px; width: fit-content; margin: 5px auto;">UNLOCK</div> "UNLOCK" is displayed for 3 seconds.	1. When the power is on, disc is in tray, press and hold [OK], [B] and [Y] on the remote control at the same time for more than 5 seconds. - "00 RET" is displayed on the unit's display. 2. Repeatedly press [▶] on the remote control or [POWER] on the unit until "04 PRG" is displayed on the unit's display. 3. Press and hold [STOP] on the remote control until "10 OCL" is displayed on the unit's display. 4. Press [OK] on the remote control or [OPEN/CLOSE] on the unit.
		*When press [OPEN/CLOSE] key while the tray being locked. <div style="border: 1px solid black; padding: 5px; width: fit-content; margin: 5px auto;">LOCK</div> Display "LOCK" for 3 seconds.	Press [OPEN/CLOSE] key while the tray is being locked.
Progressive initialization	The progressive setting is initialized to Interlace.	1. <div style="border: 1px solid black; padding: 5px; width: fit-content; margin: 5px auto;">00 RET</div> 2. <div style="border: 1px solid black; padding: 5px; width: fit-content; margin: 5px auto;">04 PRG</div>	1. When the power is on, press and hold [OK], [B] and [Y] on the remote control at the same time for more than 5 seconds. - "00 RET" is displayed on the unit's display. 2. Repeatedly press [▶] on the remote control or [POWER] on the unit until "04 PRG" is displayed on the unit's display. 3. Press and hold [OK] on the remote control or [OPEN/CLOSE] on the unit.

Item		FL display	Key operation
Mode name	Description		Front Key
Switch the TV system	Switch the TV system to another one.	1. <div style="border: 1px solid black; padding: 5px; width: fit-content; margin: 5px auto;">00 RET</div> 2. <div style="border: 1px solid black; padding: 5px; width: fit-content; margin: 5px auto;">05 P/N</div>	1. While the unit is on, press and hold [OK], [B] and [Y] on the remote control at the same time for more than 5 seconds. - "00 RET" is displayed on the unit's display. 2. Repeatedly press [▶] on the remote control or [POWER] on the unit until "05 P/N" is displayed on the unit's display. 3. Press [OK] on the remote control.
Deep Colour initialization	The Deep Colour setting is initialized.	1. <div style="border: 1px solid black; padding: 5px; width: fit-content; margin: 5px auto;">00 RET</div> 2. <div style="border: 1px solid black; padding: 5px; width: fit-content; margin: 5px auto;">07 DC</div>	1. While the unit is on, press and hold [OK], [B] and [Y] on the remote control at the same time for more than 5 seconds. - "00 RET" is displayed on the unit's display. 2. Repeatedly press [▶] on the remote control or [POWER] on the unit until "07 DC" is displayed on the unit's display. 3. Press [OK] on the remote control.
Set 4k/60p output to "OFF"	Set 4k/60p output to "OFF", and set the output to HDMI (ver. 1.4) equivalent.	1. <div style="border: 1px solid black; padding: 5px; width: fit-content; margin: 5px auto;">00 RET</div> 2. <div style="border: 1px solid black; padding: 5px; width: fit-content; margin: 5px auto;">13 L4K</div>	1. While the unit is on, press and hold [OK], [B] and [Y] on the remote control at the same time for more than 5 seconds. - "00 RET" is displayed on the unit's display. 2. Repeatedly press [▶] on the remote control or [POWER] on the unit until "13 L4K" is displayed on the unit's display. 3. Press [OK] on the remote control.

### 7.1.3. Service Modes at a glance

Information necessary for service can be displayed.

Service mode setting:

1. Turn the power off.
2. Press the [5] [9] and [RED] button simultaneously for 5 seconds, then "70 RET" is displayed on FL.
3. Press the [▶] button to select until "80 SRV" is displayed on FL.
4. Press the [OK] button.
5. It is displayed on FL as "WELCOME-->SERV".: It is shown to have entered the service mode.
6. The command is transmitted by attached remote control.

Remote Control:

[R] = [RED]

[Y] = [YELLOW]

[B] = [BLUE]







Method of making clear service mode: Press the power button (power off).

The display of information to each command is as follows.

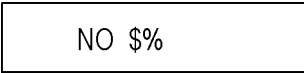
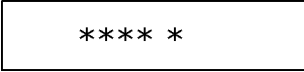
**NOTE:**

Do not use it excluding the designated command.

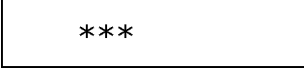
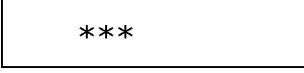
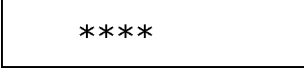
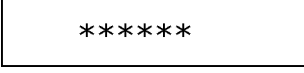
Item		FL display	Key operation
Mode name	Description		(Remote control key)
Release Items	Item of Service Mode executing is cancelled.	<div style="border: 1px solid black; padding: 5px; width: fit-content; margin: 0 auto;">SERV</div>	Press [0] [0] in service mode.
Error Code Display	Last Error Code of U/H/F held by Timer is displayed on FL. *Details are described in " <b>7.1.1. Self-Diagnosis Functions</b> ".	<div style="border: 1px solid black; padding: 5px; width: fit-content; margin: 0 auto;">♣ □ □</div> <p>* ♣ shows U/H/F. □ □ shows number.</p> <p>If any error history does not exist, [F00] is displayed.</p>	Press [0] [1] in service mode

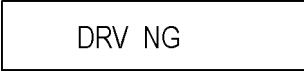
Item		FL display	Key operation (Remote control key)
Mode name	Description		
ROM Version Display	1. Region code (displayed for 5 sec.) 2. Main firm version (displayed for 5 sec.) 3. Timer firm version (displayed for 5 sec.) 4. Drive firm version (displayed for 5 sec.) 5. ROM correction version (displayed for 5 sec.) 6. B00T2 version (displayed for 5 sec.) 7. B00T3 version (displayed for 5 sec.) 8. JPEG version (displayed for 5 sec.) 9. Voice version (left displayed)	1.  \$: Region of DVD (Example: 1,2.....) %: Region of BD (Example: A,B.....) 2.  3.  4.  5.  6.  7.  8.  9.  * are version displays.	Press [0] [2] in service mode.
Drive application check	Checking whether the drive is applicable drive or not.	When the drive is applicable drive.  When the drive is not applicable drive. 	Press [0] [3] in service mode.

Item		FL display	Key operation (Remote control key)
Mode name	Description		
HDD READ SEEK Inspection	Inspecting seek time of HDD to inspect performance.	<p>At start.</p> <div style="text-align: center;"> <div style="border: 1px solid black; padding: 5px; width: fit-content; margin: 0 auto;">AVSCAN</div> <p style="text-align: center;">↓</p> <div style="border: 1px solid black; padding: 5px; width: fit-content; margin: 0 auto;">* 0</div> <p style="text-align: center;">↓</p> </div> <p>The [*] sign is added every approx. 10 seconds while inspecting. Two digits on the right side are the progress level of the inspection (The unit is %). Example on the way of inspection:</p> <div style="text-align: center;"> <div style="border: 1px solid black; padding: 5px; width: fit-content; margin: 0 auto;">*** 53</div> </div> <p>When HDD is OK after inspection:</p> <div style="text-align: center;"> <div style="border: 1px solid black; padding: 5px; width: fit-content; margin: 0 auto;">HDD OK</div> </div> <p>(NG is displayed when error is excluding 0) (Transfer rate is calculated from the AV scanning result, and when it is less than 35Mbps, NG is displayed.)</p> <div style="text-align: center;"> <div style="border: 1px solid black; padding: 5px; width: fit-content; margin: 0 auto;">HDD\$##</div> </div> <p>\$: [X] is displayed when seek time is over 270msec., there is error or transfer rate is NG. Position at \$ is space when excluding those. ##: Number of data of over 100msec. and less than 270msec. When it is over 100, [99] is displayed. When the number is less than 5, we judge it normal.</p>	<p>Press [3] [1] in service mode. * When cancelling the inspection mode while executing, do "forced power-off". Method: Press [POWER] key on the main unit more than 4 seconds.</p>

Item		FL display	Key operation (Remote control key)
Mode name	Description		
HDD READ VERIFY Inspection	Measure of access time in READ VERIFY MODE of HDD.	<p>At start.</p> <div style="text-align: center;"> <div style="border: 1px solid black; padding: 5px; width: fit-content; margin: 0 auto;">AVSCAN</div> <p style="text-align: center;">↓</p> <div style="border: 1px solid black; padding: 5px; width: fit-content; margin: 0 auto;">* 0</div> <p style="text-align: center;">↓</p> </div> <p>The [*] sign is added every approx. 10 seconds while inspecting. Two digits on the right side are the progress level of the inspection (The unit is %). Example on the way of inspection:</p> <div style="text-align: center;"> <div style="border: 1px solid black; padding: 5px; width: fit-content; margin: 0 auto;">*** 53</div> </div> <p>When HDD is OK after inspection:</p> <div style="text-align: center;"> <div style="border: 1px solid black; padding: 5px; width: fit-content; margin: 0 auto;">HDD OK</div> </div> <p>(NG is displayed when error is excluding 0) (Transfer rate is calculated from the AV scanning result, and when it is less than 35Mbps, NG is displayed.)</p> <div style="text-align: center;"> <div style="border: 1px solid black; padding: 5px; width: fit-content; margin: 0 auto;">HDD\$##</div> </div> <p>\$: [X] is displayed when seek time is over 270msec., there is error or transfer rate is NG. Position at \$ is space when excluding those. ##: Number of data of over 100msec. and less than 270msec. When it is over 100, [99] is displayed. When the number is less than 5, we judge it normal.</p>	<p>Press [3] [2] in service mode. * When cancelling the inspection mode while executing, do "forced power-off". Method: Press [POWER] key on the main unit more than 4 seconds.</p>
HDD Spin-up time	The accumulation value of the Spin-up time of HDD is displayed.	<div style="text-align: center;"> <div style="border: 1px solid black; padding: 5px; width: fit-content; margin: 0 auto;">*****</div> </div> <p>Spin-up time of HDD is displayed. (The unit of display is hour.)</p>	Press [3] [3] in service mode.

Item		FL display	Key operation (Remote control key)
Mode name	Description		
HDD Simple AV Scan Check	Simple AV scan check of HDD.	<div style="text-align: center;"> <div style="border: 1px solid black; padding: 5px; width: fit-content; margin: 0 auto;">AVSCAN</div> <p style="text-align: center;">↓</p> <div style="border: 1px solid black; padding: 5px; width: fit-content; margin: 0 auto;">STEP 01</div> <p style="text-align: center;">↓</p> <div style="border: 1px solid black; padding: 5px; width: fit-content; margin: 0 auto;">STEP 09</div> <p style="text-align: center;">↓</p> <div style="border: 1px solid black; padding: 5px; width: fit-content; margin: 0 auto;">* 0</div> <p style="text-align: center;">↓</p> <p>The [*] sign is added every 10 seconds while inspecting. Two digits on the right side are the progress level of the inspection (The unit is %). Example on the way of inspection:</p> <div style="border: 1px solid black; padding: 5px; width: fit-content; margin: 0 auto;">*** 53</div> <p>When HDD is OK after inspection:</p> <div style="border: 1px solid black; padding: 5px; width: fit-content; margin: 0 auto;">HDD OK</div> <p>When HDD is NG after inspection:</p> <div style="border: 1px solid black; padding: 5px; width: fit-content; margin: 0 auto;">HDD ***</div> <p>[*] is the number of data of NG.</p> </div>	Press [3] [6] in service mode. * When cancelling the inspection mode while executing, do "forced power-off". Method: Press [POWER] key on the main unit more than 4 seconds.
HDD Check	Simple quality judgement of HDD.	<div style="text-align: center;"> <div style="border: 1px solid black; padding: 5px; width: fit-content; margin: 0 auto;">HDDCHK</div> <p style="text-align: center;">↓</p> <p>When HDD is OK:</p> <div style="border: 1px solid black; padding: 5px; width: fit-content; margin: 0 auto;">HDD OK</div> <p>When HDD is NG:</p> <div style="border: 1px solid black; padding: 5px; width: fit-content; margin: 0 auto;">HDD NG</div> </div>	Press [3] [7] in service mode.

Item		FL display	Key operation (Remote control key)
Mode name	Description		
HDD/BD Drive Simple Check	Check if HDD Self-Diagnosis test was performed or Drive last error occurred within 4 weeks. * If the current date or the date when the error occurred is wrong, correct judgement may not be made.	<p>HDD Self-Diagnosis test start.</p> <div style="border: 1px solid black; padding: 5px; width: fit-content; margin: 5px auto;">HDDCHK</div> <p>When HDD Self-Diagnosis test result is OK.</p> <div style="border: 1px solid black; padding: 5px; width: fit-content; margin: 5px auto;">HDD OK</div> <p>When HDD Self-Diagnosis test result is NG.</p> <div style="border: 1px solid black; padding: 5px; width: fit-content; margin: 5px auto;">HDD NG</div> <p>When the drive malfunction was detected within 4 weeks ago.</p> <div style="border: 1px solid black; padding: 5px; width: fit-content; margin: 5px auto;">DRV NG</div> <p>When the drive malfunction was detected more than 4 weeks ago or Drive last error data does not exist.</p> <div style="border: 1px solid black; padding: 5px; width: fit-content; margin: 5px auto;">DRV OK</div> <p>[HDD OK] from [DRV OK] are repeatedly displayed in turn.</p>	Press [3][8] in service mode.
Laser Used Time Indication	Check laser used time (hours) of drive.	<p>Laser used time: BD Playback</p> <div style="border: 1px solid black; padding: 5px; width: fit-content; margin: 5px auto;">BP*****</div> <p>Laser used time: BD Recording</p> <div style="border: 1px solid black; padding: 5px; width: fit-content; margin: 5px auto;">BR*****</div> <p>Laser used time: DVD Playback</p> <div style="border: 1px solid black; padding: 5px; width: fit-content; margin: 5px auto;">DP*****</div> <p>Laser used time: DVD Recording</p> <div style="border: 1px solid black; padding: 5px; width: fit-content; margin: 5px auto;">DR*****</div> <p>Laser used time: CD Playback</p> <div style="border: 1px solid black; padding: 5px; width: fit-content; margin: 5px auto;">CD*****</div> <p>Display those repeatedly.</p> <p>●(*****) is the used time display in hour. ●Laser used time of BD/DVD/CD in Playback/Recording mode is counted.</p>	Press [4] [1] in service mode.

Item		FL display	Key operation (Remote control key)
Mode name	Description		
BD Drive Last Error	BD Drive error code display. *For details about the drive error code, refer to the Service Manual for the specific BD Drive.	<p>1. Error Number is displayed for 5 seconds.</p> <div style="border: 1px solid black; padding: 5px; width: fit-content; margin: 5px auto;">NO **</div> <p>2. The date when the error has occurred is displayed for 5 seconds.</p> <div style="border: 1px solid black; padding: 5px; width: fit-content; margin: 5px auto;">YYMMDD</div> <p>YY: Year MM: Month DD: Day</p> <p>3. Last Drive Error (1/2) is displayed for 5 seconds.</p> <div style="border: 1px solid black; padding: 5px; width: fit-content; margin: 5px auto;">***** ↑</div> <p>03: Bad disc 04: Bad disc or drive malfunction</p> <p>4. Last Drive Error (2/2) is displayed for 5 seconds.</p> <div style="border: 1px solid black; padding: 5px; width: fit-content; margin: 5px auto;">*****</div> <p>5. Error occurring Disc type is displayed for 5 seconds.</p> <p>DVD-ROM</p> <div style="border: 1px solid black; padding: 5px; width: fit-content; margin: 5px auto;">DVD</div> <p>CD</p> <div style="border: 1px solid black; padding: 5px; width: fit-content; margin: 5px auto;">CD</div> <p>RAM (2.6GB)</p> <div style="border: 1px solid black; padding: 5px; width: fit-content; margin: 5px auto;">RAM26</div> <p>RAM (4.7GB)</p> <div style="border: 1px solid black; padding: 5px; width: fit-content; margin: 5px auto;">RAM47</div> <p>DVDR</p> <div style="border: 1px solid black; padding: 5px; width: fit-content; margin: 5px auto;">DVDR</div>	Press [4] [2] in service mode. When "INFO*****" is being displayed, past 99 error histories can be displayed by pressing [0] [1] - [9] [9]

Item		FL display	Key operation (Remote control key)
Mode name	Description		
		DVD-RW <div style="border: 1px solid black; padding: 5px; width: fit-content; margin: 5px auto;">DVDRW</div>	
		CD-R <div style="border: 1px solid black; padding: 5px; width: fit-content; margin: 5px auto;">CDR</div>	
		CD-RW <div style="border: 1px solid black; padding: 5px; width: fit-content; margin: 5px auto;">CDRW</div>	
		DVD+R <div style="border: 1px solid black; padding: 5px; width: fit-content; margin: 5px auto;">DVDPR</div>	
		DVD+RW <div style="border: 1px solid black; padding: 5px; width: fit-content; margin: 5px auto;">DVDPRW</div>	
		BD-ROM <div style="border: 1px solid black; padding: 5px; width: fit-content; margin: 5px auto;">BDROM</div>	
		BD-RE <div style="border: 1px solid black; padding: 5px; width: fit-content; margin: 5px auto;">BDRE</div>	
		BD-R <div style="border: 1px solid black; padding: 5px; width: fit-content; margin: 5px auto;">BDR</div>	
		BD-ROM (Multiple Layer) <div style="border: 1px solid black; padding: 5px; width: fit-content; margin: 5px auto;">BDXROM</div>	
		BD-RE (Multiple Layer) <div style="border: 1px solid black; padding: 5px; width: fit-content; margin: 5px auto;">BDXRE</div>	
		BD-R (Multiple Layer) <div style="border: 1px solid black; padding: 5px; width: fit-content; margin: 5px auto;">BDXR</div>	
		Others <div style="border: 1px solid black; padding: 5px; width: fit-content; margin: 5px auto;">MEDIA *</div>	
		* is displayed the responded value from RTSC.	

Item		FL display	Key operation (Remote control key)																																																																																																					
Mode name	Description																																																																																																							
		<p>6. Disc Maker ID is displayed for 5 seconds.</p> <div style="border: 1px solid black; padding: 5px; text-align: center;">*****</div> <p>7. Factor of Drive Error (hexadecimal) occurring is left displayed.</p> <div style="border: 1px solid black; padding: 5px; text-align: center;">**++□□</div> <p>** : Error occurring operation code (This is not used) ++ : Error occurring disc type</p> <table border="1" style="width: 100%; border-collapse: collapse;"> <tr><td>00</td><td>DVD-ROM</td></tr> <tr><td>01</td><td>CD</td></tr> <tr><td>02</td><td>2.6GB DVD-RAM</td></tr> <tr><td>03</td><td>4.7GB DVD-RAM</td></tr> <tr><td>04</td><td>DVD-R</td></tr> <tr><td>After 05</td><td>Others</td></tr> </table> <p>□□ : Error occurring disc situation</p> <table border="1" style="width: 100%; border-collapse: collapse;"> <thead> <tr> <th rowspan="2">Display</th> <th colspan="4">Detail</th> </tr> <tr> <th>Disc distinction</th> <th>With or without Cartridge</th> <th>Disc cart-ridge state</th> <th>Size</th> </tr> </thead> <tbody> <tr><td>00</td><td>OK</td><td>With</td><td>Not opened</td><td>12cm</td></tr> <tr><td>10</td><td>OK</td><td>With</td><td>Not opened</td><td>8cm</td></tr> <tr><td>20</td><td>OK</td><td>With</td><td>Opened</td><td>12cm</td></tr> <tr><td>30</td><td>OK</td><td>With</td><td>Opened</td><td>8cm</td></tr> <tr><td>40</td><td>OK</td><td>Without</td><td>Not opened</td><td>12cm</td></tr> <tr><td>50</td><td>OK</td><td>Without</td><td>Not opened</td><td>8cm</td></tr> <tr><td>60</td><td>OK</td><td>Without</td><td>Opened</td><td>12cm</td></tr> <tr><td>70</td><td>OK</td><td>Without</td><td>Opened</td><td>8cm</td></tr> <tr><td>80</td><td>NG</td><td>With</td><td>Not opened</td><td>12cm</td></tr> <tr><td>90</td><td>NG</td><td>With</td><td>Not opened</td><td>8cm</td></tr> <tr><td>A0</td><td>NG</td><td>With</td><td>Opened</td><td>12cm</td></tr> <tr><td>B0</td><td>NG</td><td>With</td><td>Opened</td><td>8cm</td></tr> <tr><td>C0</td><td>NG</td><td>Without</td><td>Not opened</td><td>12cm</td></tr> <tr><td>D0</td><td>NG</td><td>Without</td><td>Not opened</td><td>8cm</td></tr> <tr><td>E0</td><td>NG</td><td>Without</td><td>Opened</td><td>12cm</td></tr> <tr><td>F0</td><td>NG</td><td>Without</td><td>Opened</td><td>8cm</td></tr> </tbody> </table> <p>8. When the last error does not exist.</p> <div style="border: 1px solid black; padding: 5px; text-align: center;">NODATA</div>	00	DVD-ROM	01	CD	02	2.6GB DVD-RAM	03	4.7GB DVD-RAM	04	DVD-R	After 05	Others	Display	Detail				Disc distinction	With or without Cartridge	Disc cart-ridge state	Size	00	OK	With	Not opened	12cm	10	OK	With	Not opened	8cm	20	OK	With	Opened	12cm	30	OK	With	Opened	8cm	40	OK	Without	Not opened	12cm	50	OK	Without	Not opened	8cm	60	OK	Without	Opened	12cm	70	OK	Without	Opened	8cm	80	NG	With	Not opened	12cm	90	NG	With	Not opened	8cm	A0	NG	With	Opened	12cm	B0	NG	With	Opened	8cm	C0	NG	Without	Not opened	12cm	D0	NG	Without	Not opened	8cm	E0	NG	Without	Opened	12cm	F0	NG	Without	Opened	8cm	In case that the maker cannot be identified, display is black out.
00	DVD-ROM																																																																																																							
01	CD																																																																																																							
02	2.6GB DVD-RAM																																																																																																							
03	4.7GB DVD-RAM																																																																																																							
04	DVD-R																																																																																																							
After 05	Others																																																																																																							
Display	Detail																																																																																																							
	Disc distinction	With or without Cartridge	Disc cart-ridge state	Size																																																																																																				
00	OK	With	Not opened	12cm																																																																																																				
10	OK	With	Not opened	8cm																																																																																																				
20	OK	With	Opened	12cm																																																																																																				
30	OK	With	Opened	8cm																																																																																																				
40	OK	Without	Not opened	12cm																																																																																																				
50	OK	Without	Not opened	8cm																																																																																																				
60	OK	Without	Opened	12cm																																																																																																				
70	OK	Without	Opened	8cm																																																																																																				
80	NG	With	Not opened	12cm																																																																																																				
90	NG	With	Not opened	8cm																																																																																																				
A0	NG	With	Opened	12cm																																																																																																				
B0	NG	With	Opened	8cm																																																																																																				
C0	NG	Without	Not opened	12cm																																																																																																				
D0	NG	Without	Not opened	8cm																																																																																																				
E0	NG	Without	Opened	12cm																																																																																																				
F0	NG	Without	Opened	8cm																																																																																																				
Play BER confirmation	Measures play BER of DVD-RAM, BD-RE DL (Ver2.0) media and displays the measurement result.	<p>Measuring start. (Measuring in process)</p> <div style="border: 1px solid black; padding: 5px; text-align: center;">BER</div> <p>The measuring result.</p> <div style="border: 1px solid black; padding: 5px; text-align: center;">a_bx_c</div> <p>When an error occurs while measuring.</p> <div style="border: 1px solid black; padding: 5px; text-align: center;">ERROR</div> <p>When DVD-RAM or BD-RE DL (Ver2.0) is not inserted.</p> <div style="border: 1px solid black; padding: 5px; text-align: center;">NODISC</div>	<p>1. Insert <u>DVD-RAM or BD-RE DL (Ver2.0) disc</u> into BD Drive in service mode. 2. Press [4] [3].</p>																																																																																																					

Item		FL display	Key operation (Remote control key)															
Mode name	Description																	
Laser power confirmation	Drive state is judged based on difference between laser power value at shipping and present laser power value.	<p>Measuring starts. (Measuring in process)</p> <div style="border: 1px solid black; padding: 5px; width: fit-content; margin: 5px auto;">POWER</div> <p>When the measuring result is OK.</p> <div style="border: 1px solid black; padding: 5px; width: fit-content; margin: 5px auto;">OK *</div> <p>When the measuring result is NG.</p> <div style="border: 1px solid black; padding: 5px; width: fit-content; margin: 5px auto;">NG *</div> <p>When disc is not inserted.</p> <div style="border: 1px solid black; padding: 5px; width: fit-content; margin: 5px auto;">NODISC</div> <p>When an error occurs while measuring.</p> <div style="border: 1px solid black; padding: 5px; width: fit-content; margin: 5px auto;">ERROR</div> <p>* is judgement result</p> <table border="1" style="margin: 5px auto;"> <thead> <tr> <th>*</th> <th>Power value difference</th> <th>Evaluation</th> </tr> </thead> <tbody> <tr> <td>0</td> <td>1mW or less</td> <td>Very good.</td> </tr> <tr> <td>1</td> <td>2mW or less</td> <td>Good.</td> </tr> <tr> <td>2</td> <td>3mW or less</td> <td>Bad.</td> </tr> <tr> <td>3</td> <td>4mW or more</td> <td>Very bad.</td> </tr> </tbody> </table> <p>If disc is not inserted, [NO DISC] is displayed. If power value study was filed, [ERROR] is displayed.</p>	*	Power value difference	Evaluation	0	1mW or less	Very good.	1	2mW or less	Good.	2	3mW or less	Bad.	3	4mW or more	Very bad.	<p>1. Insert the 5X media DVD-RAM into the tray. (Incompatible with other media) 2. Press [4] [4].</p>
*	Power value difference	Evaluation																
0	1mW or less	Very good.																
1	2mW or less	Good.																
2	3mW or less	Bad.																
3	4mW or more	Very bad.																
CEC (H) output	Check of the CEC terminal high output of HDMI.	<p>When the check is OK.</p> <div style="border: 1px solid black; padding: 5px; width: fit-content; margin: 5px auto;">CECHOK</div> <p>When the check is NG.</p> <div style="border: 1px solid black; padding: 5px; width: fit-content; margin: 5px auto;">CECHNG</div>	Press [5] [5] in service mode.															
CEC (L) output	Check of the CEC terminal low output of HDMI.	<p>When the check is OK.</p> <div style="border: 1px solid black; padding: 5px; width: fit-content; margin: 5px auto;">CECLOK</div> <p>When the check is NG.</p> <div style="border: 1px solid black; padding: 5px; width: fit-content; margin: 5px auto;">CECLNG</div>	Press [5] [6] in service mode.															
Production Date Display	Display the date when the unit was produced.	<div style="border: 1px solid black; padding: 5px; width: fit-content; margin: 5px auto;">YYMMDD</div> <p>YY: Year MM: Month DD: Day</p>	Press [6] [1] in service mode.															

Item		FL display	Key operation																																																																																																												
Mode name	Description		(Remote control key)																																																																																																												
Factory default value	Displays values set at the factory.	Factory default value.  <div style="border: 1px solid black; padding: 5px; width: fit-content; margin: 0 auto;">(0)(1)(4)(5)(6)(7)</div>	Press [6] [2] in service mode.																																																																																																												
Test progress management value	Displays AV scan result.	When AV scan result is present <div style="border: 1px solid black; padding: 5px; width: fit-content; margin: 0 auto;">VERIFY</div> Number of values less than -10 ms <table border="1" style="margin: 0 auto;"> <tr><td>1</td><td>U</td><td>** (UPPER)</td></tr> <tr><td></td><td>M</td><td>**** (MEDIUM)</td></tr> <tr><td></td><td>L</td><td>**** (LOWER)</td></tr> </table> Number of values less than -20 ms <table border="1" style="margin: 0 auto;"> <tr><td>2</td><td>U</td><td>** (UPPER)</td></tr> <tr><td></td><td>M</td><td>**** (MEDIUM)</td></tr> <tr><td></td><td>L</td><td>**** (LOWER)</td></tr> </table> Number of values less than -30 ms <table border="1" style="margin: 0 auto;"> <tr><td>3</td><td>U</td><td>** (UPPER)</td></tr> <tr><td></td><td>M</td><td>**** (MEDIUM)</td></tr> <tr><td></td><td>L</td><td>**** (LOWER)</td></tr> </table> Number of values less than -40 ms <table border="1" style="margin: 0 auto;"> <tr><td>4</td><td>U</td><td>** (UPPER)</td></tr> <tr><td></td><td>M</td><td>**** (MEDIUM)</td></tr> <tr><td></td><td>L</td><td>**** (LOWER)</td></tr> </table> Number of values less than -50 ms <table border="1" style="margin: 0 auto;"> <tr><td>5</td><td>U</td><td>** (UPPER)</td></tr> <tr><td></td><td>M</td><td>**** (MEDIUM)</td></tr> <tr><td></td><td>L</td><td>**** (LOWER)</td></tr> </table> Number of values less than -60 ms <table border="1" style="margin: 0 auto;"> <tr><td>6</td><td>U</td><td>** (UPPER)</td></tr> <tr><td></td><td>M</td><td>**** (MEDIUM)</td></tr> <tr><td></td><td>L</td><td>**** (LOWER)</td></tr> </table> Number of values less than -70 ms <table border="1" style="margin: 0 auto;"> <tr><td>7</td><td>U</td><td>** (UPPER)</td></tr> <tr><td></td><td>M</td><td>**** (MEDIUM)</td></tr> <tr><td></td><td>L</td><td>**** (LOWER)</td></tr> </table> Number of values less than -80 ms <table border="1" style="margin: 0 auto;"> <tr><td>8</td><td>U</td><td>** (UPPER)</td></tr> <tr><td></td><td>M</td><td>**** (MEDIUM)</td></tr> <tr><td></td><td>L</td><td>**** (LOWER)</td></tr> </table> Number of values less than -90 ms <table border="1" style="margin: 0 auto;"> <tr><td>9</td><td>U</td><td>** (UPPER)</td></tr> <tr><td></td><td>M</td><td>**** (MEDIUM)</td></tr> <tr><td></td><td>L</td><td>**** (LOWER)</td></tr> </table> Number of values less than -100 (or 150) ms <table border="1" style="margin: 0 auto;"> <tr><td>A</td><td>U</td><td>** (UPPER)</td></tr> <tr><td></td><td>M</td><td>**** (MEDIUM)</td></tr> <tr><td></td><td>L</td><td>**** (LOWER)</td></tr> </table> Number of values less than -100 (or 150) to 270 ms <table border="1" style="margin: 0 auto;"> <tr><td>B</td><td>U</td><td>** (UPPER)</td></tr> <tr><td></td><td>M</td><td>**** (MEDIUM)</td></tr> <tr><td></td><td>L</td><td>**** (LOWER)</td></tr> </table> Number of Seek error's <table border="1" style="margin: 0 auto;"> <tr><td>R</td><td>U</td><td>** (UPPER)</td></tr> <tr><td></td><td>M</td><td>**** (MEDIUM)</td></tr> <tr><td></td><td>L</td><td>**** (LOWER)</td></tr> </table>	1	U	** (UPPER)		M	**** (MEDIUM)		L	**** (LOWER)	2	U	** (UPPER)		M	**** (MEDIUM)		L	**** (LOWER)	3	U	** (UPPER)		M	**** (MEDIUM)		L	**** (LOWER)	4	U	** (UPPER)		M	**** (MEDIUM)		L	**** (LOWER)	5	U	** (UPPER)		M	**** (MEDIUM)		L	**** (LOWER)	6	U	** (UPPER)		M	**** (MEDIUM)		L	**** (LOWER)	7	U	** (UPPER)		M	**** (MEDIUM)		L	**** (LOWER)	8	U	** (UPPER)		M	**** (MEDIUM)		L	**** (LOWER)	9	U	** (UPPER)		M	**** (MEDIUM)		L	**** (LOWER)	A	U	** (UPPER)		M	**** (MEDIUM)		L	**** (LOWER)	B	U	** (UPPER)		M	**** (MEDIUM)		L	**** (LOWER)	R	U	** (UPPER)		M	**** (MEDIUM)		L	**** (LOWER)	Press [6] [3] in service mode.
1	U	** (UPPER)																																																																																																													
	M	**** (MEDIUM)																																																																																																													
	L	**** (LOWER)																																																																																																													
2	U	** (UPPER)																																																																																																													
	M	**** (MEDIUM)																																																																																																													
	L	**** (LOWER)																																																																																																													
3	U	** (UPPER)																																																																																																													
	M	**** (MEDIUM)																																																																																																													
	L	**** (LOWER)																																																																																																													
4	U	** (UPPER)																																																																																																													
	M	**** (MEDIUM)																																																																																																													
	L	**** (LOWER)																																																																																																													
5	U	** (UPPER)																																																																																																													
	M	**** (MEDIUM)																																																																																																													
	L	**** (LOWER)																																																																																																													
6	U	** (UPPER)																																																																																																													
	M	**** (MEDIUM)																																																																																																													
	L	**** (LOWER)																																																																																																													
7	U	** (UPPER)																																																																																																													
	M	**** (MEDIUM)																																																																																																													
	L	**** (LOWER)																																																																																																													
8	U	** (UPPER)																																																																																																													
	M	**** (MEDIUM)																																																																																																													
	L	**** (LOWER)																																																																																																													
9	U	** (UPPER)																																																																																																													
	M	**** (MEDIUM)																																																																																																													
	L	**** (LOWER)																																																																																																													
A	U	** (UPPER)																																																																																																													
	M	**** (MEDIUM)																																																																																																													
	L	**** (LOWER)																																																																																																													
B	U	** (UPPER)																																																																																																													
	M	**** (MEDIUM)																																																																																																													
	L	**** (LOWER)																																																																																																													
R	U	** (UPPER)																																																																																																													
	M	**** (MEDIUM)																																																																																																													
	L	**** (LOWER)																																																																																																													

Item		FL display	Key operation (Remote control key)
Mode name	Description		
		Number of Retry's <div style="border: 1px solid black; padding: 2px; width: fit-content; margin: 5px auto;">b*****</div> When AV scan result is OK <div style="border: 1px solid black; padding: 2px; width: fit-content; margin: 5px auto;">HDD OK</div> When AV scan result is NG <div style="border: 1px solid black; padding: 2px; width: fit-content; margin: 5px auto;">HDD NG</div> When AV scan result is not present <div style="border: 1px solid black; padding: 2px; width: fit-content; margin: 5px auto;">NODATA</div> VERIFY, 1***** to b***** (displayed for 5 sec.) HDD OK or HDD NG remains displayed.	
Display the Error History	Display the Error History stored on the unit. * If the current date or the date when the error occurred is wrong, correct judgement may not be made.	When the drive malfunction was detected within 4 weeks ago. (*) <div style="border: 1px solid black; padding: 2px; width: fit-content; margin: 5px auto;">DRV NG</div> When the drive malfunction was detected more than 4 weeks ago or Drive last error data does not exist. <div style="border: 1px solid black; padding: 2px; width: fit-content; margin: 5px auto;">DRV OK</div> When HDD Self-Diagnosis test result is NG. <div style="border: 1px solid black; padding: 2px; width: fit-content; margin: 5px auto;">HDD NG</div> When HDD Self-Diagnosis test result is OK. <div style="border: 1px solid black; padding: 2px; width: fit-content; margin: 5px auto;">HDD OK</div> The Error History is not Data for HDD and BD Drive. <div style="border: 1px solid black; padding: 2px; width: fit-content; margin: 5px auto;">OK</div> The Error History is not Data. <div style="border: 1px solid black; padding: 2px; width: fit-content; margin: 5px auto;">NODATA</div> HDD Self-Diagnosis test in process. <div style="border: 1px solid black; padding: 2px; width: fit-content; margin: 5px auto;">HDDCHK</div>	Press [6] [5] in service mode.

Item		FL display	Key operation (Remote control key)
Mode name	Description		
Write/Read function for service history information	Function to write data (service history information) consisting of a 6-digit number to the memory area of the main unit, and function to read service history information and display it on FL. Up to 3 pieces of service history information can be stored.	<ul style="list-style-type: none"> <li>• Write</li> <li>1. <div style="border: 1px solid black; padding: 5px; width: fit-content; margin: 5px auto;">MEMO</div></li> <li>2. <div style="border: 1px solid black; padding: 5px; width: fit-content; margin: 5px auto;">*****</div></li> <li>3. Write success: <div style="border: 1px solid black; padding: 5px; width: fit-content; margin: 5px auto;">MEMOOK</div></li> <li>4. Write failure: <div style="border: 1px solid black; padding: 5px; width: fit-content; margin: 5px auto;">MEMONG</div></li> <li>• Read</li> <li>5. <div style="border: 1px solid black; padding: 5px; width: fit-content; margin: 5px auto;">MEMO</div></li> <li>6. Read success: <div style="border: 1px solid black; padding: 5px; width: fit-content; margin: 5px auto;">*****</div></li> <li>7. Read failure: <div style="border: 1px solid black; padding: 5px; width: fit-content; margin: 5px auto;">MEMONG</div></li> </ul>	<ul style="list-style-type: none"> <li>• Write procedure</li> <li>1. Press [6]→[6] during service mode.</li> <li>2. Press [1] →[*] on the remote control. Specify a memory area number (1 to 3) for [*].</li> <li>3. 4. If data (service history information) consisting of a 6-digit number is transferred from the remote control, the 6-digit number is written to the memory area with a specified number. If [0] is transferred to all the digits, the default state is restored.</li> <li>• Read procedure</li> <li>5. Transfer [6]→[6] from the remote control.</li> <li>6.7. Press [0] →[*] on the remote control. Specify a memory area number (1 to 3) for [*]. Read the service history information from the memory area with the specified number.</li> </ul>
Self-Diagnosis inspection history	Displays Self-Diagnosis inspection history.	Self-Diagnosis inspection history: <div style="border: 1px solid black; padding: 5px; width: fit-content; margin: 5px auto;">(0)(1)(2)(3)(4)(5)</div>	Press [6] [7] in service mode.
Function inspection history	Displays functions inspection history.	Function inspection history: <div style="border: 1px solid black; padding: 5px; width: fit-content; margin: 5px auto;">(0)(1)(2)(3)(4)(5)</div>	Press [6] [8] in service mode.

Item		FL display	Key operation (Remote control key)
Mode name	Description		
Saves malfunction history, user remote control operation history and HDD history collectively to USB memory.	Writes malfunction history, user remote control operation history and HDD history collectively onto USB memory.	<p>When history information is not present.</p> <div style="border: 1px solid black; padding: 5px; width: fit-content; margin: 5px auto;">NODATA</div> <p>When saving to USB memory is not possible.</p> <div style="border: 1px solid black; padding: 5px; width: fit-content; margin: 5px auto;">ERROR</div> <p>When USB memory cannot recognize.</p> <div style="border: 1px solid black; padding: 5px; width: fit-content; margin: 5px auto;">NO DEV</div> <p>While saving data to USB storage device.</p> <div style="border: 1px solid black; padding: 5px; width: fit-content; margin: 5px auto;">SAVE</div> <p>When writing finishes.</p> <div style="border: 1px solid black; padding: 5px; width: fit-content; margin: 5px auto;">FIN</div> <p>Note: Name of saved file is *FTREXXXX.TXT (malfunction history) *LOGSXXXX.TXT (user remote control operation history) (XXXX: software version number) *HDDHIST1.TXT (HDD history) *LOG?????.TXT (HDD history)</p> <div style="margin-left: 20px;"> <p>NUMBER DATE MONTH</p> </div> <p>To obtain multiple pieces of deck information of the same software version in one USB memory, move files already obtained or change the file names.</p>	<ol style="list-style-type: none"> <li>1. Prepare a USB memory to export data from the unit.</li> <li>2. Insert the USB memory in the service mode.</li> <li>3. Press [6] [9] in service mode.</li> </ol>
Registration of additional USB-HDD	To register USB-HDD for inspection. (Special mode)	<p>When USB-HDD is in Special mode (available for registered USB-HDD):</p> <div style="border: 1px solid black; padding: 5px; width: fit-content; margin: 5px auto;">EXTHDD</div> <p>When Special mode failure (USB-HDD registration impossible):</p> <div style="border: 1px solid black; padding: 5px; width: fit-content; margin: 5px auto;">EXT NG</div>	<p>Press [7] [4] in service mode. * When releasing this mode, press the [POWER] button of the unit or Remote Control. After releasing the special mode, registration in the special mode is cancelled.</p> <p>Details are described in "3.1.3.4. Registration procedure of USB-HDD for inspection".</p>

Item		FL display	Key operation (Remote control key)
Mode name	Description		
USB-HDD READ SEEK Inspection	Inspecting seek time of USB-HDD to inspect performance.	<p>At start.</p> <div style="text-align: center;"> <div style="border: 1px solid black; padding: 5px; width: fit-content; margin: 0 auto;">AVSCAN</div> <p style="text-align: center;">↓</p> <div style="border: 1px solid black; padding: 5px; width: fit-content; margin: 0 auto;">* 0</div> <p style="text-align: center;">↓</p> </div> <p>The [*] sign is added every approx. 10 seconds while inspecting. Two digits on the right side are the progress level of the inspection (The unit is %). Example on the way of inspection:</p> <div style="text-align: center;"> <div style="border: 1px solid black; padding: 5px; width: fit-content; margin: 0 auto;">*** 53</div> </div> <p>When USB-HDD is OK after inspection:</p> <div style="text-align: center;"> <div style="border: 1px solid black; padding: 5px; width: fit-content; margin: 0 auto;">HDD OK</div> </div> <p>(NG is displayed when error is excluding 0) (Transfer rate is calculated from the AV scanning result, and when it is less than 35Mbps, NG is displayed.)</p> <div style="text-align: center;"> <div style="border: 1px solid black; padding: 5px; width: fit-content; margin: 0 auto;">HDD\$##</div> </div> <p>\$: [X] is displayed when seek time is over 270msec., there is error or transfer rate is NG. Position at \$ is space when excluding those. ##: Number of data of over 100msec. and less than 270msec. When it is over 100, [99] is displayed. When the number is less than 5, we judge it normal.</p> <p>When the USB-HDD is not applicable.</p> <div style="text-align: center;"> <div style="border: 1px solid black; padding: 5px; width: fit-content; margin: 0 auto;">NO_SUP</div> </div>	<p>Press [7] [5] in service mode. * When cancelling the inspection mode while executing, do "forced power-off". Method: Press [POWER] key on the main unit more than 4 seconds.</p>

Item		FL display	Key operation (Remote control key)
Mode name	Description		
USB-HDD READ VERIFY Inspection	Measure of access time in READ VERIFY MODE of USB-HDD.	<p>At start.</p> <div style="text-align: center;"> <div style="border: 1px solid black; padding: 5px; width: fit-content; margin: 0 auto;">AVSCAN</div> <p style="text-align: center;">↓</p> <div style="border: 1px solid black; padding: 5px; width: fit-content; margin: 0 auto;">* 0</div> <p style="text-align: center;">↓</p> </div> <p>The [*] sign is added every approx. 10 seconds while inspecting. Two digits on the right side are the progress level of the inspection (The unit is %). Example on the way of inspection:</p> <div style="text-align: center;"> <div style="border: 1px solid black; padding: 5px; width: fit-content; margin: 0 auto;">*** 53</div> </div> <p>When USB-HDD is OK after inspection:</p> <div style="text-align: center;"> <div style="border: 1px solid black; padding: 5px; width: fit-content; margin: 0 auto;">HDD OK</div> </div> <p>(NG is displayed when error is excluding 0) (Transfer rate is calculated from the AV scanning result, and when it is less than 35Mbps, NG is displayed.)</p> <div style="text-align: center;"> <div style="border: 1px solid black; padding: 5px; width: fit-content; margin: 0 auto;">HDD\$##</div> </div> <p>\$: [X] is displayed when seek time is over 270msec., there is error or transfer rate is NG. Position at \$ is space when excluding those. ##: Number of data of over 100msec. and less than 270msec. When it is over 100, [99] is displayed. When the number is less than 5, we judge it normal.</p> <p>When the USB-HDD is not applicable.</p> <div style="text-align: center;"> <div style="border: 1px solid black; padding: 5px; width: fit-content; margin: 0 auto;">NO_SUP</div> </div>	<p>Press [7] [6] in service mode. * When cancelling the inspection mode while executing, do "forced power-off". Method: Press [POWER] key on the main unit more than 4 seconds.</p>

Item		FL display	Key operation (Remote control key)
Mode name	Description		
USB-HDD Simple AV Scan Check	Simple AV scan check of USB-HDD.	<div style="text-align: center;"> <div style="border: 1px solid black; padding: 5px; width: fit-content; margin: 0 auto;">AVSCAN</div> <p style="text-align: center;">↓</p> <div style="border: 1px solid black; padding: 5px; width: fit-content; margin: 0 auto;">STEP 01</div> <p style="text-align: center;">↓</p> <div style="border: 1px solid black; padding: 5px; width: fit-content; margin: 0 auto;">STEP 07</div> <p style="text-align: center;">↓</p> <div style="border: 1px solid black; padding: 5px; width: fit-content; margin: 0 auto;">* 0</div> <p style="text-align: center;">↓</p> </div> <p>The [*] sign is added every 10 seconds while inspecting. Two digits on the right side are the progress level of the inspection (The unit is %). Example on the way of inspection:</p> <div style="text-align: center;"> <div style="border: 1px solid black; padding: 5px; width: fit-content; margin: 0 auto;">*** 53</div> </div> <p>When USB-HDD is OK after inspection:</p> <div style="text-align: center;"> <div style="border: 1px solid black; padding: 5px; width: fit-content; margin: 0 auto;">HDD OK</div> </div> <p>When USB-HDD is NG after inspection:</p> <div style="text-align: center;"> <div style="border: 1px solid black; padding: 5px; width: fit-content; margin: 0 auto;">HDD ***</div> </div> <p>[*] is the number of data of NG.</p>	<p>Press [7] [7] in service mode. * When cancelling the inspection mode while executing, do "forced power-off". Method: Press [POWER] key on the main unit more than 4 seconds.</p>
USB-HDD Check	Simple quality judgement of USB-HDD.	<div style="text-align: center;"> <div style="border: 1px solid black; padding: 5px; width: fit-content; margin: 0 auto;">HDDCHK</div> <p style="text-align: center;">↓</p> </div> <p>When USB-HDD is OK:</p> <div style="text-align: center;"> <div style="border: 1px solid black; padding: 5px; width: fit-content; margin: 0 auto;">HDD OK</div> </div> <p>When USB-HDD is NG:</p> <div style="text-align: center;"> <div style="border: 1px solid black; padding: 5px; width: fit-content; margin: 0 auto;">HDD NG</div> </div>	<p>Press [7] [8] in service mode.</p>
Tray OPEN/CLOSE Test	The tray is opened and closed repeatedly.	<div style="text-align: center;"> <div style="border: 1px solid black; padding: 5px; width: fit-content; margin: 0 auto;">*****</div> </div> <p>*** is number of open/close cycle times.</p>	<p>Press [9] [1] in service mode *When releasing this mode, press the [POWER] button of Remote Control.</p>

Item		FL display	Key operation (Remote control key)
Mode name	Description		
Delete the Laser Used Time	Laser used time stored in the memory of the unit is deleted.	CLR	Press [9] [5] in service mode.
Delete the Last Drive Error	Delete the Last Drive Error information stored on the BD Drive.	CLR	Press [9] [6] in service mode.
Delete the Error History	Delete Error History information stored on the unit.	CLR	Press [9] [7] in service mode.
Error code initialization	Initialization of the last error code held by timer. (Write in F00)	CLR	Press [9] [8] in service mode.
Initialize Service	Last Drive Error, Error history and Error Codes stored on the unit are initialized to factory setting.	CLR	Press [9] [9] in service mode.
Finishing service mode	Release Service Mode.	Display in STOP (E-E) mode.  *****	Press power button on the front panel or Remote controller in service mode.

## 8 Service Fixture & Tools

Part Number	Description	Pcs	Compatibility
SUKZ000007 (*1)	Extension FFC (Digital P.C.B. - BD Drive / 18 Pin)	1	Same as BST950EG Series
RFKZ0578	Extension Cable (HDD Relay P.C.B. - HDD / 7 Pin)	1	Same as BST950EG Series
RFKZ0577	Extension Cable (HDD Relay P.C.B. - HDD / 15 Pin)	1	Same as BST950EG Series
RFKZ0327	Extension Cable (Digital P.C.B. - Main P.C.B. / 15 Pin)	1	Same as BST950EG Series
SVKZ000001	Lead Free Solder (0.3mm/100g Reel)		Same as BST950EG Series
SVKZ000002	Lead Free Solder (0.6mm/100g Reel)		Same as BST950EG Series
SVKZ000003	Lead Free Solder (1.0mm/100g Reel)		Same as BST950EG Series
RFKZ0316	Solder Remover (Lead free low temperature Solder/50g)		Same as BST950EG Series
RFKZ0328	Flux		Same as BST950EG Series

\* The above parts are supplied by HEBD.

\*1. Supplied by CHPAVC.

# 9 Disassembly and Assembly Instructions

**Note:**

In this document, explanations basically use illustrations of DMR-UBS90EG.  
In other models, shape of some parts may be different.

## 9.1. Unit

### 9.1.1. Disassembly Flow Chart

The following chart is the procedure for disassembling the casing and inside parts for internal inspection when carrying out the servicing.

To assemble the unit, reverse the steps shown in the chart below.

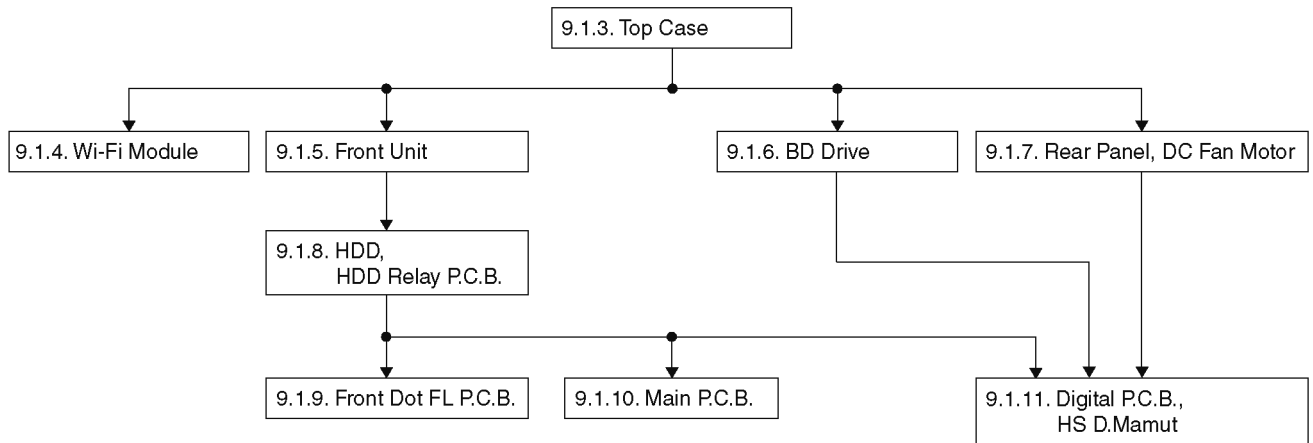

### 9.1.2. P.C.B. Positions

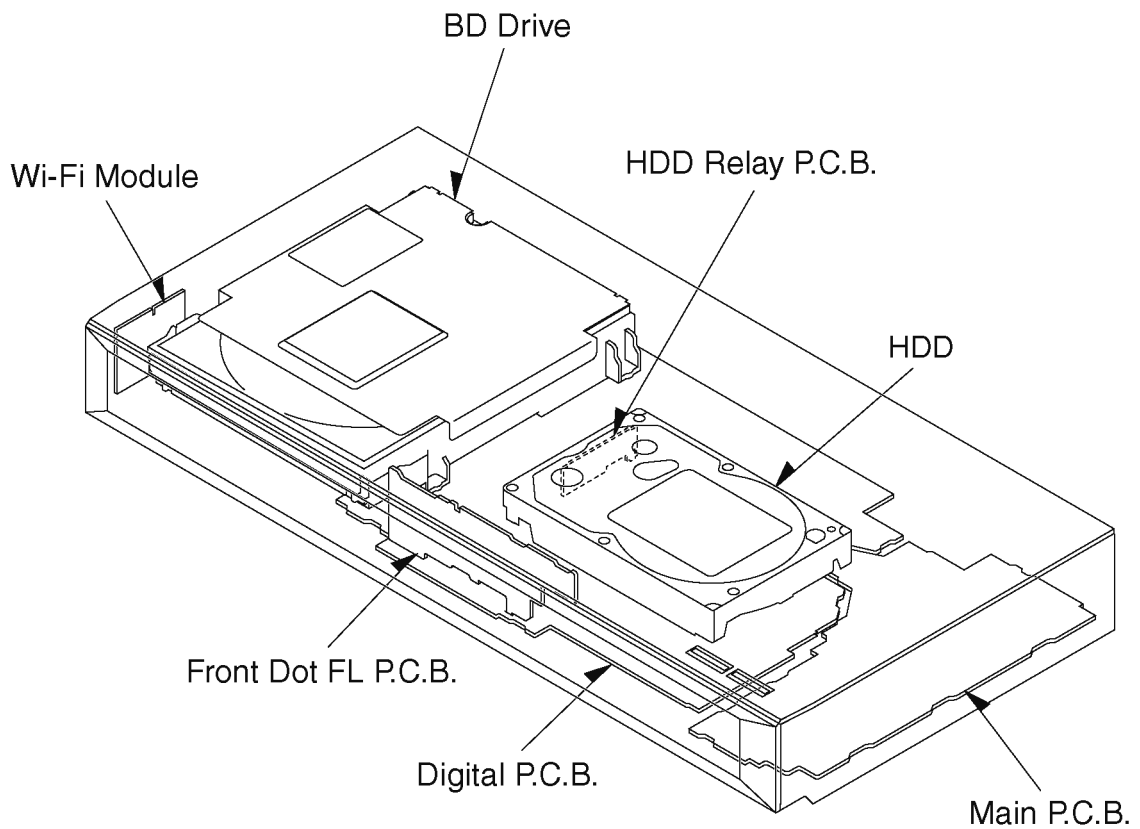

### 9.1.3. Top Case

1. Remove 3 Screws (A).
2. Slide the Top Ornament rearward and unlock 2 Locking Tabs (A), 1 Locking Tab (B) and 9 Locking Tabs (C).
3. Remove the Top Ornament in the direction of the arrow.

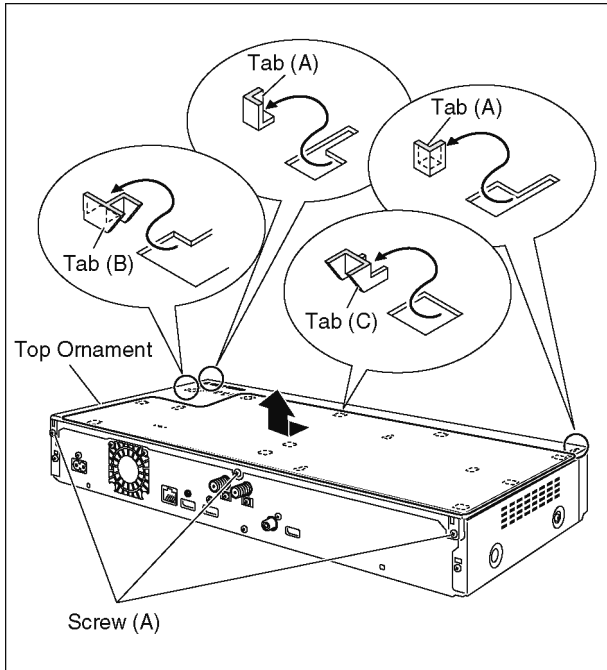

4. Remove 2 Screws (B) and 2 Screws (C).
5. Slide the Top Case rearward and open the both ends at rear side of the Top Case a little and lift the Top Case in the direction of the arrows.

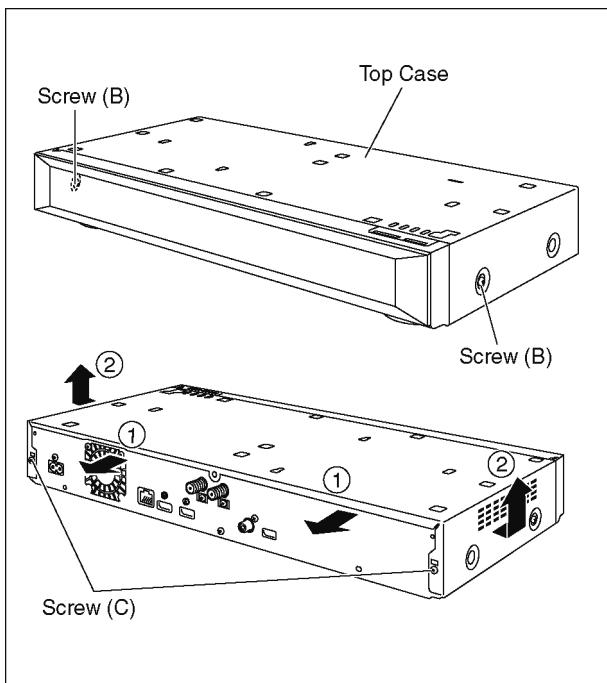

### Notes: (When attaching the Top Ornament and replacing the Top Case)

- Pushing the Top Ornament in the arrow direction, and push the hole of Top Case to the tabs of Top Ornament.

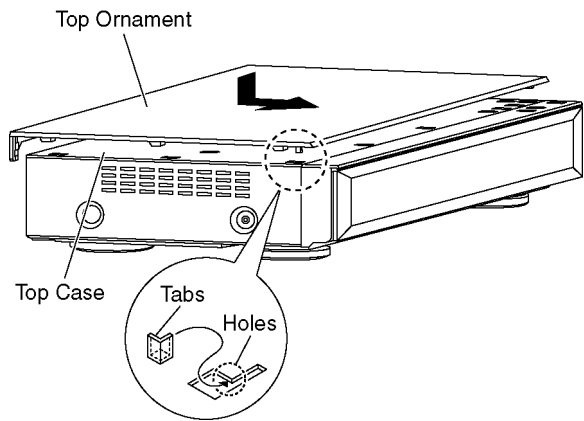

- For how to attach the Absorbing sheet, see below.

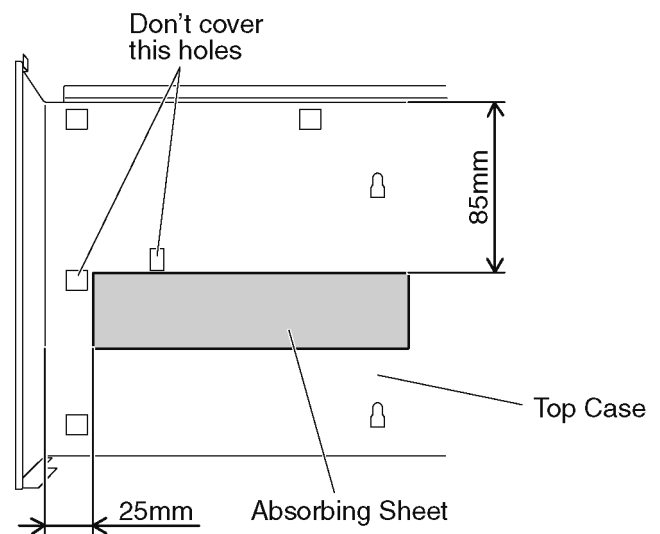

### 9.1.4. Wi-Fi Module

1. Remove 1 Screw (A) and disconnect the WLAN Cable connector.
2. Remove the Wi-Fi Module.

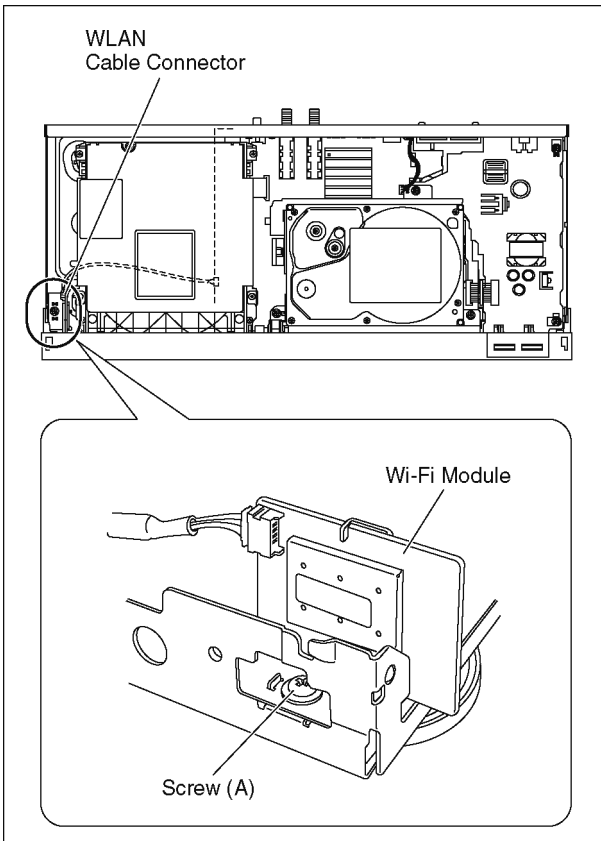

### 9.1.5. Front Unit

1. Unlock 6 Tabs (A) - (F).
2. Pull the Front Unit in the direction of your side.

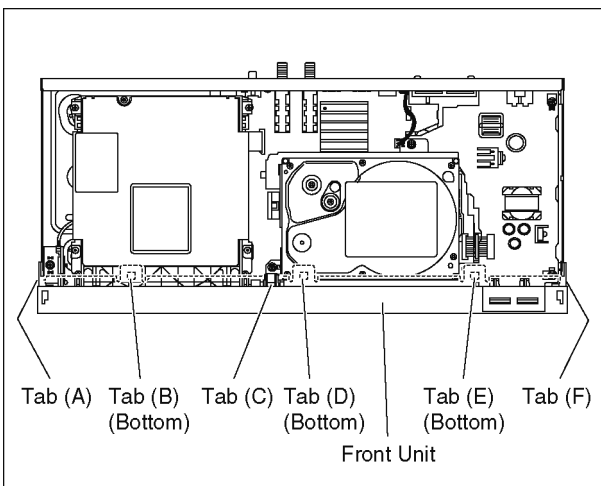

### 9.1.5.1. How to remove Door Unit

1. Remove the 1 Door Spring and remove the Door Unit with the left and right hooks up and moving the Door Unit to the left fully.

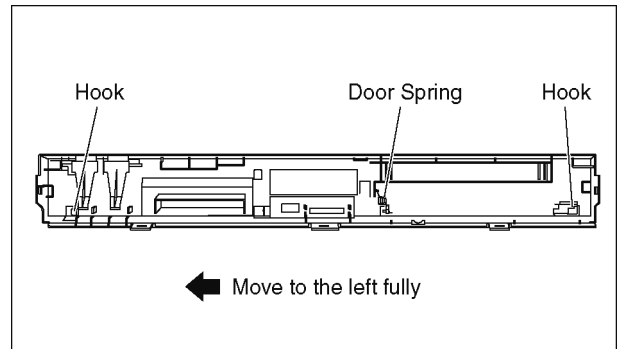

### 9.1.5.2. How to assemble Door Unit

1. Install the Door Unit as follows:
  - Insert the Groove ① of Door Unit to the Shaft ② of Front Unit.
  - Insert the Hole ③ of Door Unit into the Shaft ④ of Front Unit.
  - Insert the Hole ⑤ of Door Unit into the Shaft ⑥ of Front Unit.
  - Insert the Hole ⑦ of Door Unit into the Shaft ⑧ of Front Unit.
  - Be careful not to damage the Fulcrum part of the Door Unit when inserting the Door Unit.

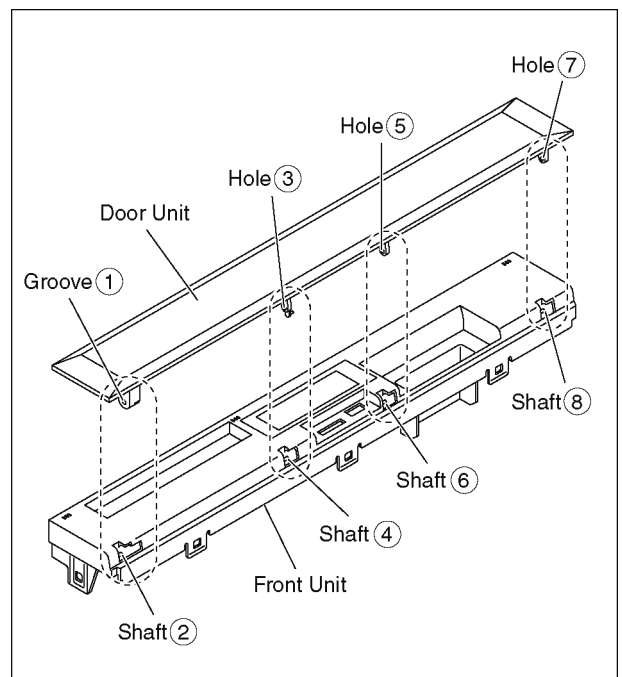

2. Install the 1 Door Spring as shown in the figure.

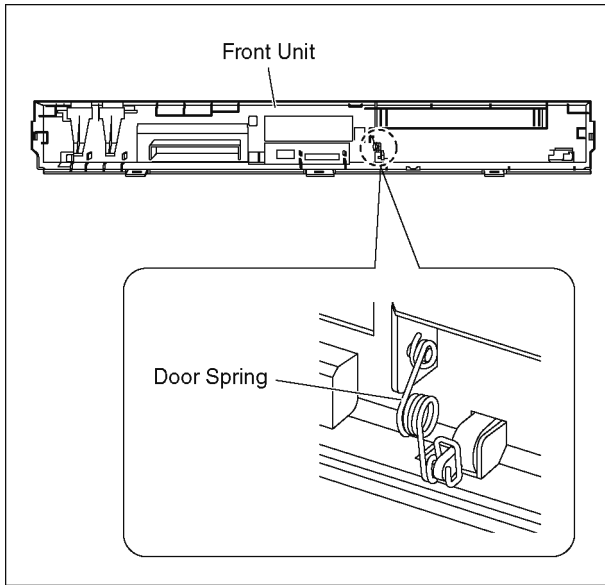

### 9.1.5.3. How to apply Hanarl to the Door Unit and Front Unit

- Hanarl application locations for the Door Unit and Front Unit.
- Hanarl is not applied to replacement parts.
- Apply adequate of the Hanarl to the designed locations. (RFKXGUD24)
- Apply the Hanarl thinly using a toothpick.

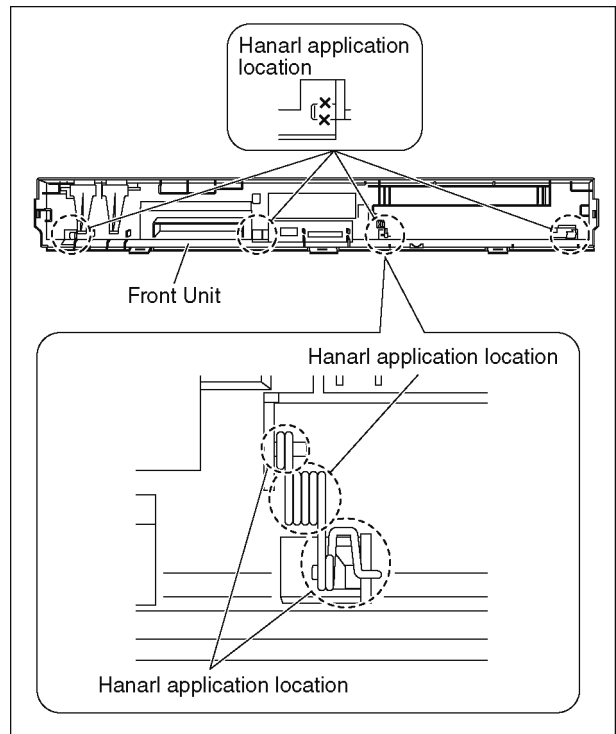
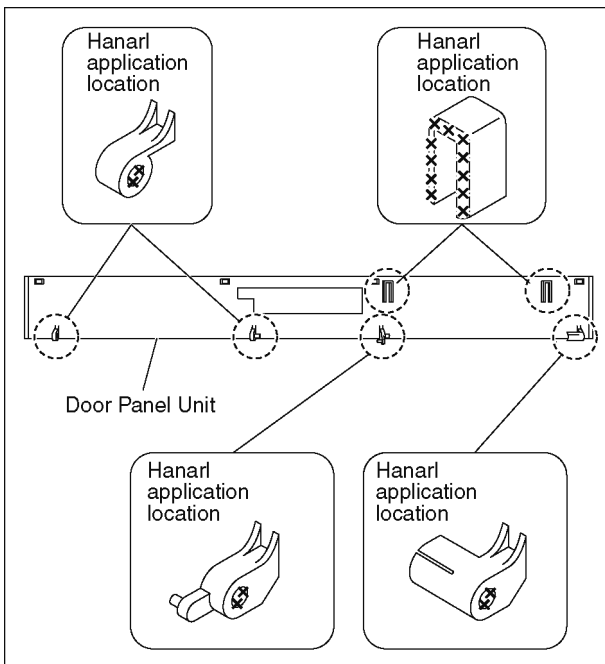

### 9.1.6. BD Drive

1. Remove 4 Screws (A) and disconnect the Drive FFC to remove BD Drive.

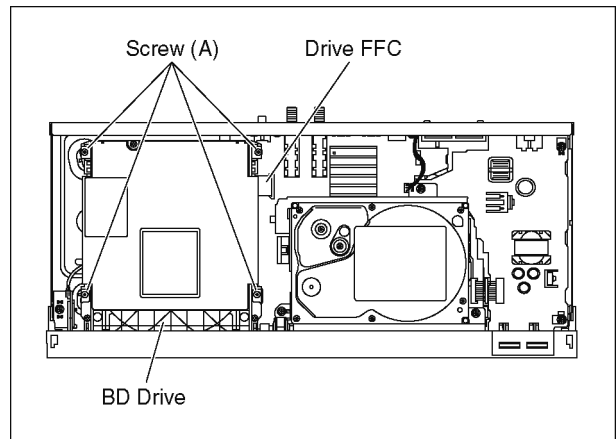

#### CAUTION:

When inserting the FFC, pay attention as below.

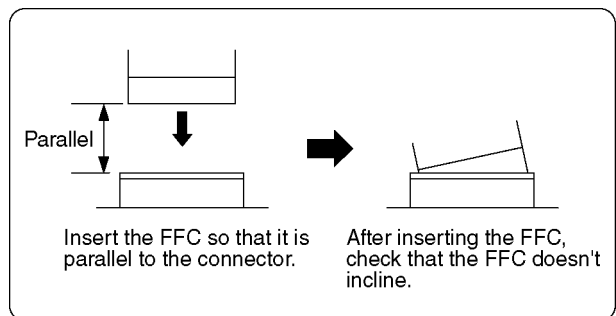

## 9.1.7. Rear Panel, DC Fan Motor

### 9.1.7.1. Only DC Fan Motor

1. Remove 2 Screws (A) and disconnect the DC Fan Motor connector.
2. Remove the DC Fan Motor.

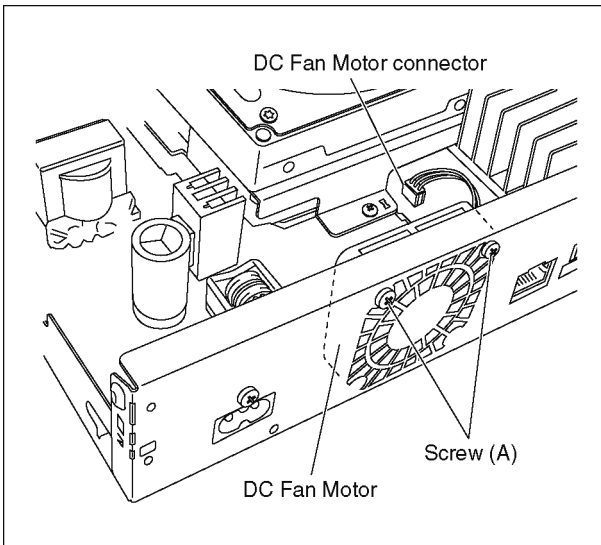

### 9.1.7.2. Rear Panel with DC Fan Motor (UBS80EG)

1. Remove 3 Screws (B) and 2 Screws (C).
2. Disconnect the DC Fan Motor connector and unlock 2 Locking Tabs (A) to remove Rear Panel.

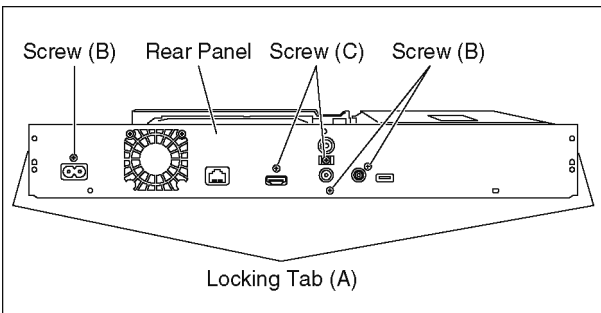

### 9.1.7.3. Rear Panel with DC Fan Motor (UBS90EG)

1. Remove 3 Screws (B) and 4 Screws (C).
2. Disconnect the DC Fan Motor connector and unlock 2 Locking Tabs (A) to remove Rear Panel.



## 9.1.8. HDD, HDD Relay P.C.B.

### Data of HDD:

Make sure to order the Part No., SUCV\*\*\*\*HDK(T) in Replacement Parts List when replacing the HDD.

The following data has been written on SUCV\*\*\*\*HDK(T).

- Main Firm
- CD DB Data
- Other Data

### Caution:

No use HDD (SUCV\*\*\*\*HDK(T)) of the capacity of the other model use.

When replacing HDD, "HDD Error" indication is displayed and HDD must be formatted.

\* How to format HDD  
Please refer to Service Navigation, and format HDD.

### Handling of HDD

The following precautions should be taken when handling HDD.

- a. Never give an impact to HDD. (Even a drop from 1cm height can be a cause of HDD failure.)
- b. When placing HDD on a workbench, provide a mat on a bench for shock absorption and anti-static purposes.
- c. When installing HDD, release it from your hands only after confirming that it is fully set on the chassis.
- d. Avoid stacking up HDD.
- e. HDD is unstable and easy to fall. Do not stand it on its side face.
- f. When handling HDD, hold its side faces to avoid static hazard.
- g. Do not place HDD on its wrapping bag after removal. (Prevention of static hazard)
- h. Use a screwdriver with low impact and anti-static features.

1. Remove 3 Screws (A) and disconnect the HDD connector to remove HDD (with HDD Relay P.C.B.).

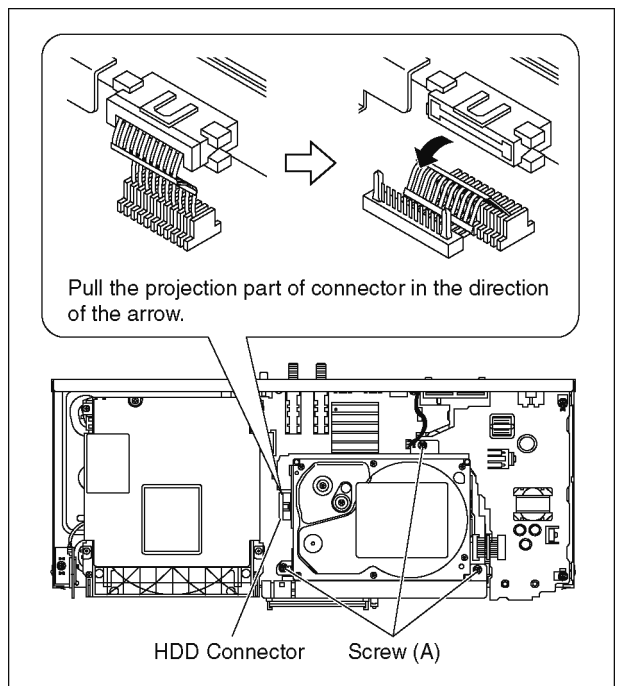

2. Put HDD upside down so as not to give a shock to HDD.

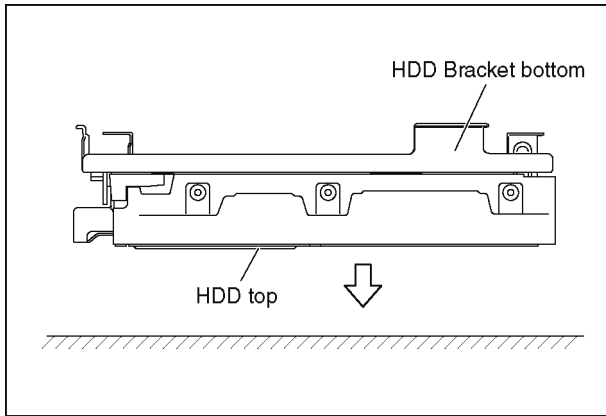

3. Remove 3 Screws (B) to remove HDD from HDD Bracket.

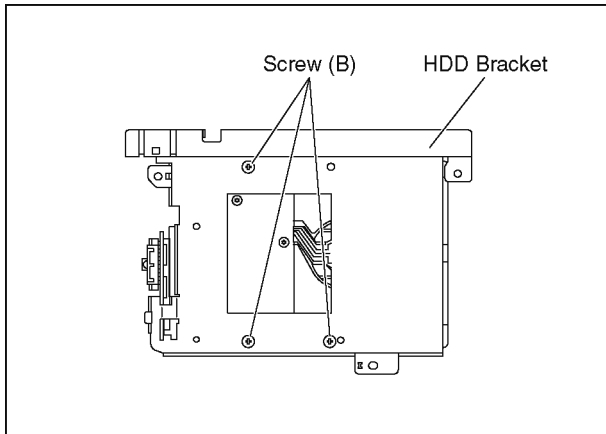

4. Pull the HDD Relay P.C.B. in the direction of the arrow.

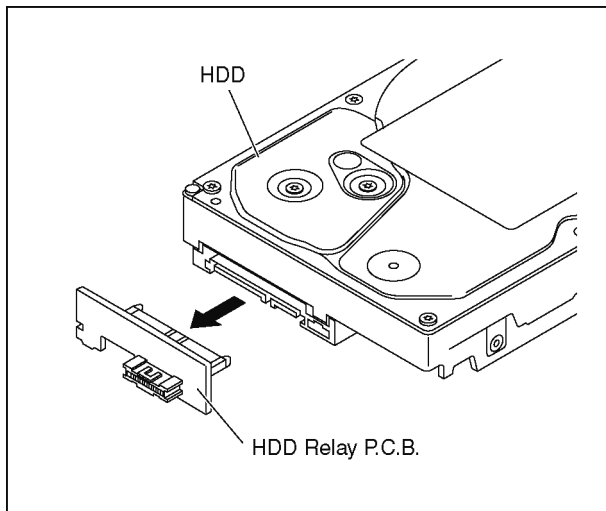

### 9.1.9. Front Dot FL P.C.B.

1. Pull up the Front Dot FL P.C.B. in the direction of the arrow.

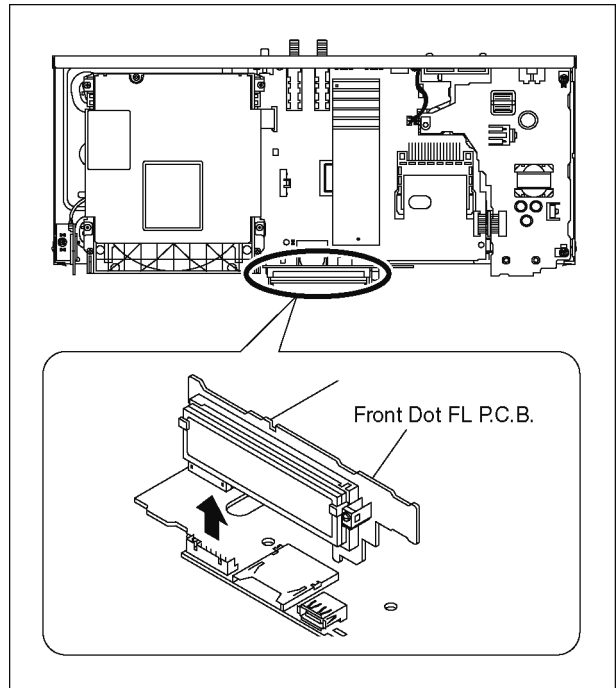

### 9.1.10. Main P.C.B.

When replacing Main P.C.B., "HDD Error" indication is displayed and HDD must be formatted.

\* How to format HDD  
Please refer to Service Navigation, and format HDD.

1. Remove 1 Screw (A) on Rear Panel.
2. Disconnect 1 connector.
3. Remove 2 Screws (B) to remove Main P.C.B.

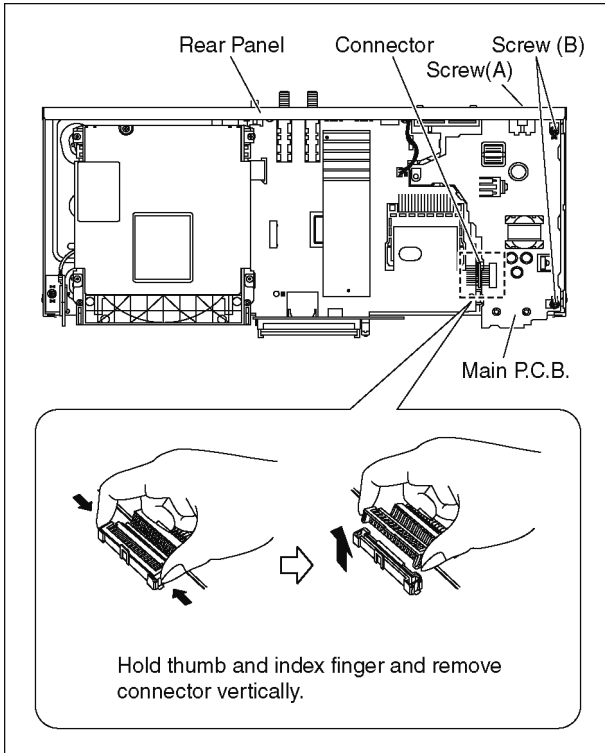

### 9.1.11. Digital P.C.B., HS D.MAMUT

1. Disconnect 1 connector and WLAN Cable connector.
2. Remove 2 Screws (A) to remove Digital P.C.B.

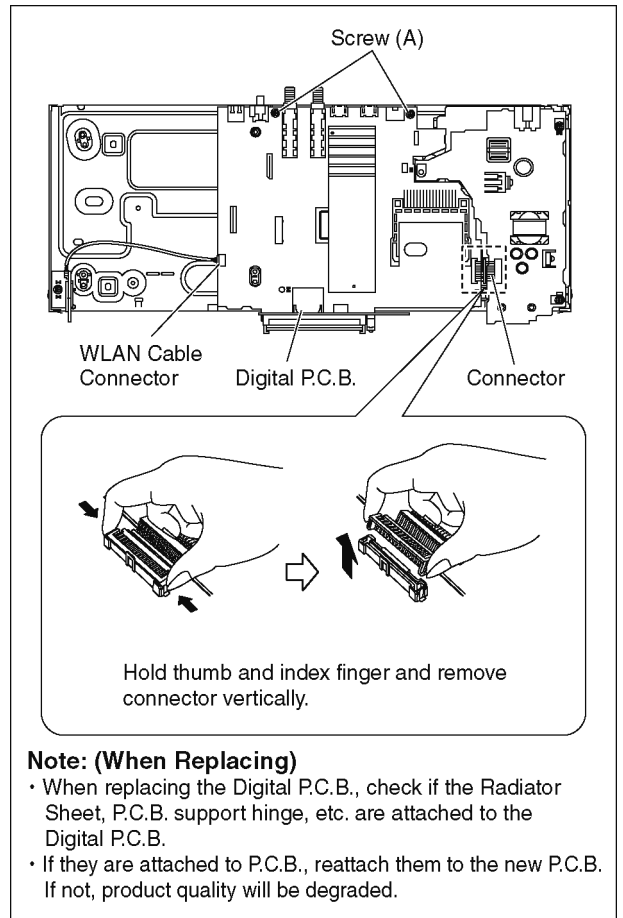

3. Remove 2 Screws (B) to remove HS D.Mamut.

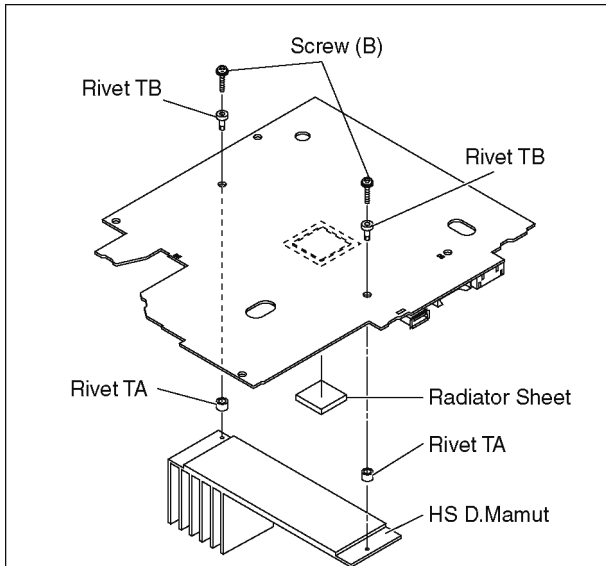

**Note : (when Replacing)**

- For how to attach the Radiator Sheet, see below.

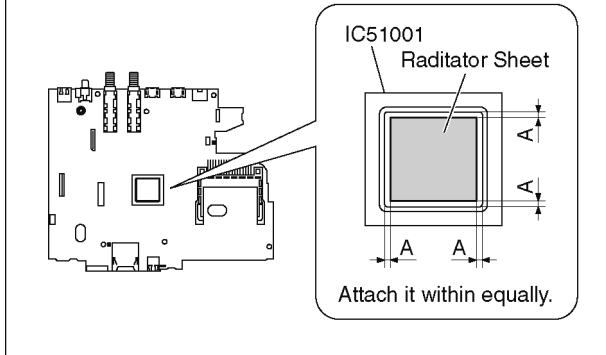

## 9.2. BD Drive

### 9.2.1. Upper Base Ass'y

1. Remove 3 Screws (A) and unlock 2 Hooks.

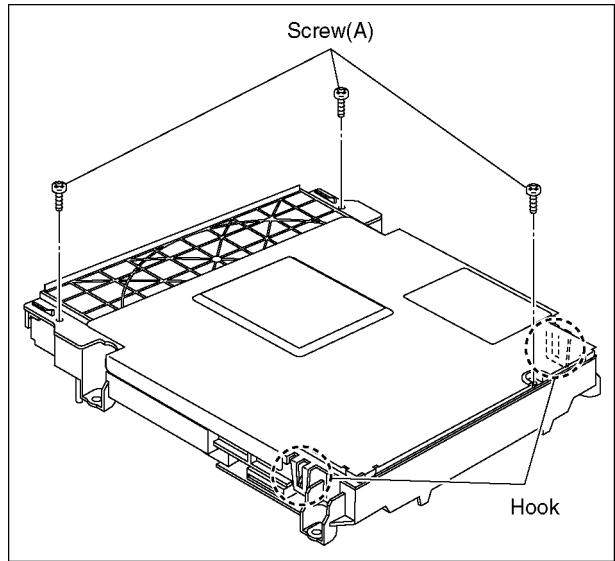

2. Lift up the Upper Base Ass'y, and pull it out to the direction of arrow.

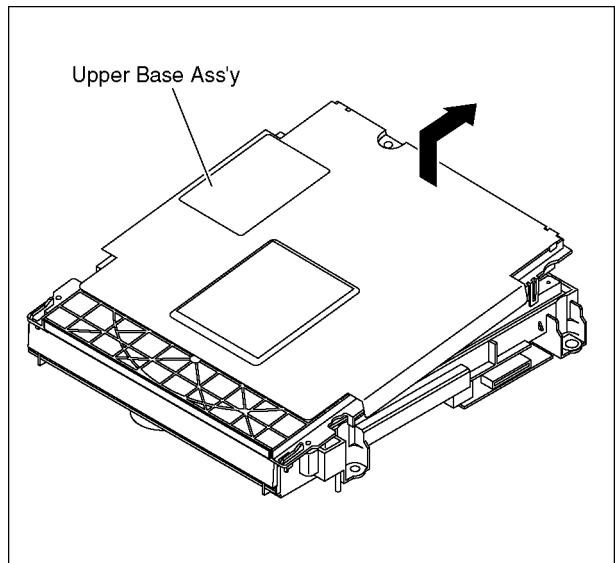

## 9.2.2. Tray

1. Perform the step "9.2.1. Upper Base Ass'y".
2. Insert the Paper Clip into the hole of the bottom side, and slide it to the direction of arrow until it can be.

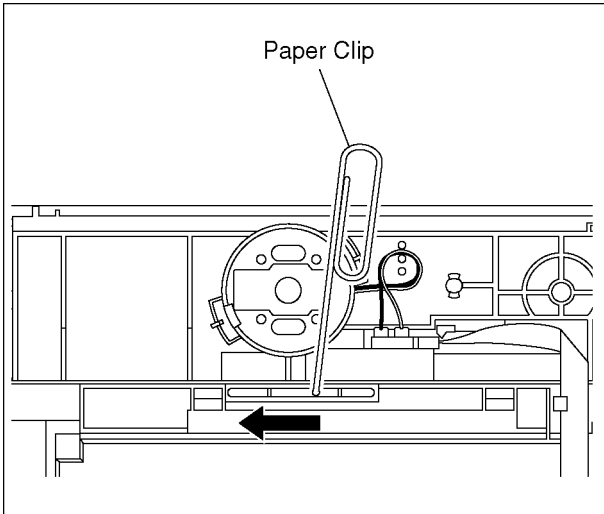

3. Pull out the Tray to the direction of arrow.

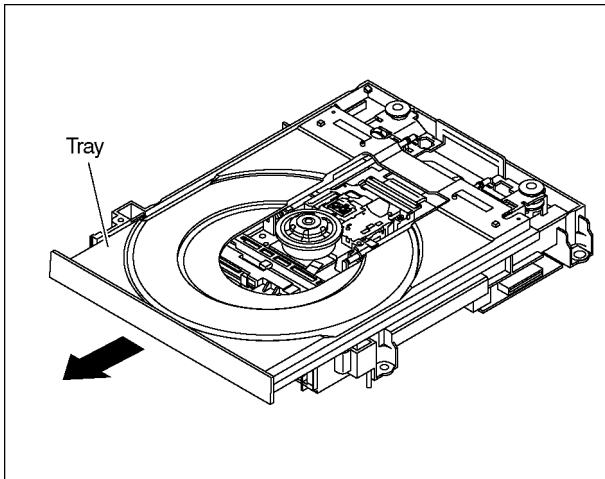

## 9.2.3. Pulley Gear, Belt and Mid Gear

1. Perform the step "9.2.2. Tray".
2. Push the post to the direction of arrow by using the slotted screwdriver.

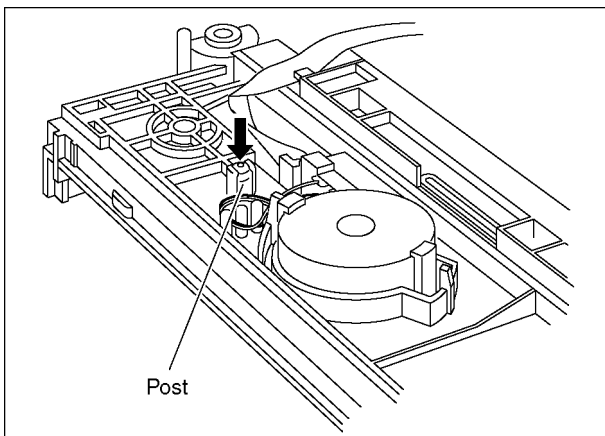

3. Remove the Pulley Gear, Belt and Mid Gear.

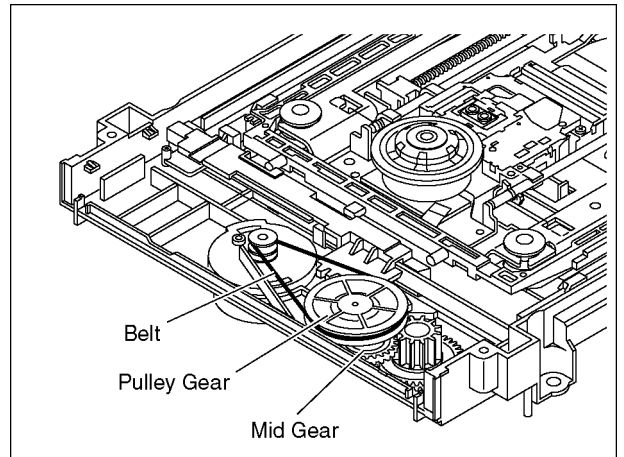

## 9.2.4. Traverse Base Ass'y and Slide Cam

1. Perform the step "9.2.3. Pulley Gear and Belt, Mid Gear".
2. Remove the Sheet.
3. Open the connector lock, and disconnect the 4 FFCs.
4. Remove 1 Screw, Heat Sink (B) and the Drive P.C.B.

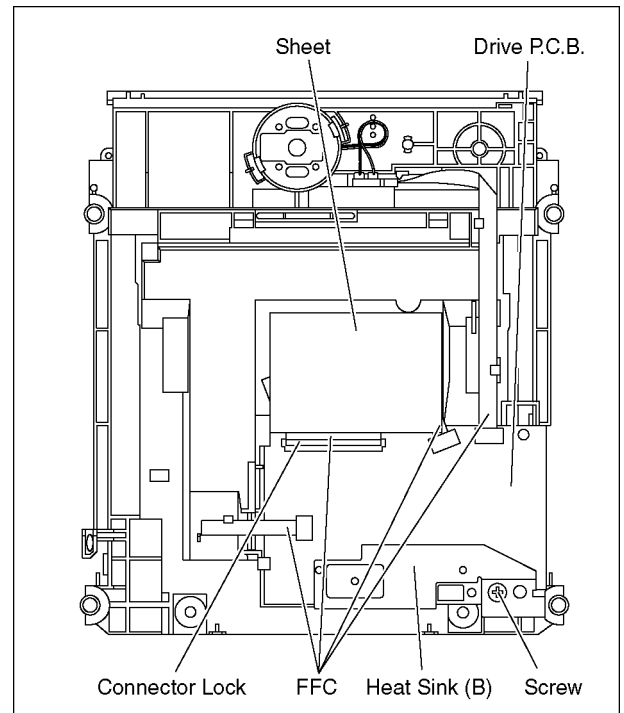

### Caution:

Though the Drive P.C.B. is not supplied as replacement parts, it must be removed for after disassembling.

5. Push and remove the 2 Rubbers in the direction of arrows.

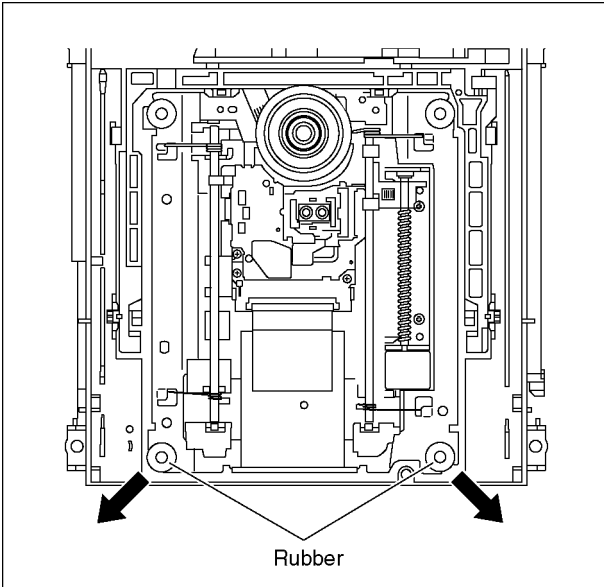

6. Open the connector lock, and disconnect the FFC.  
 7. Slide the Slide Cam to the right until it can be.  
 8. Remove the Traverse Base Ass'y with pulling the 2 hooks to the direction of arrows.

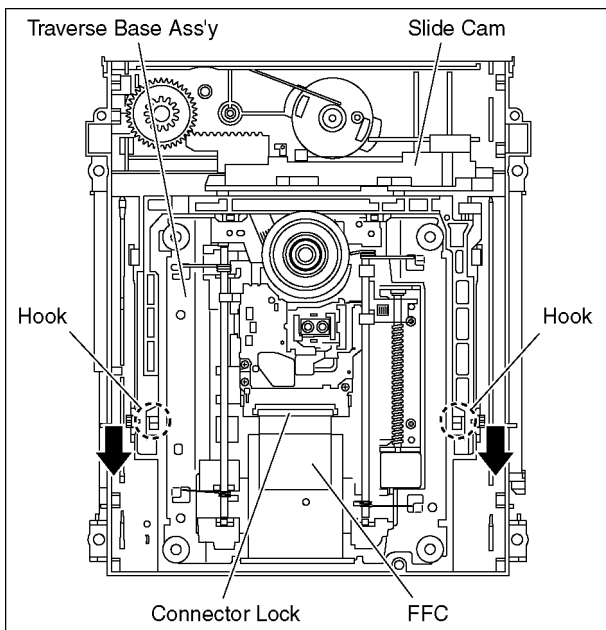

9. Remove the Slide Cam.

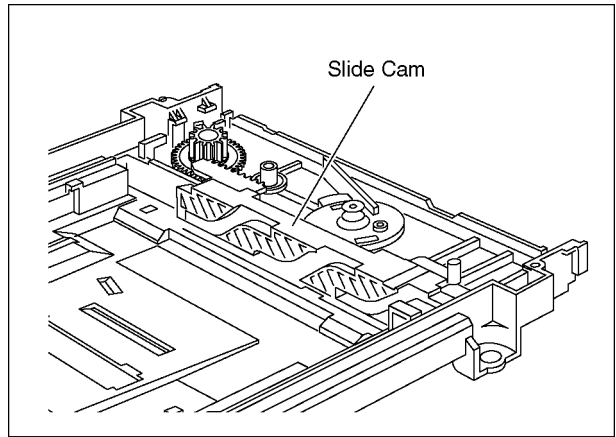

### 9.2.5. Drive Gear and Loading Motor

1. Perform the step "9.2.4. Traverse Base Ass'y and Slide Cam".  
 2. Remove the Drive Gear.

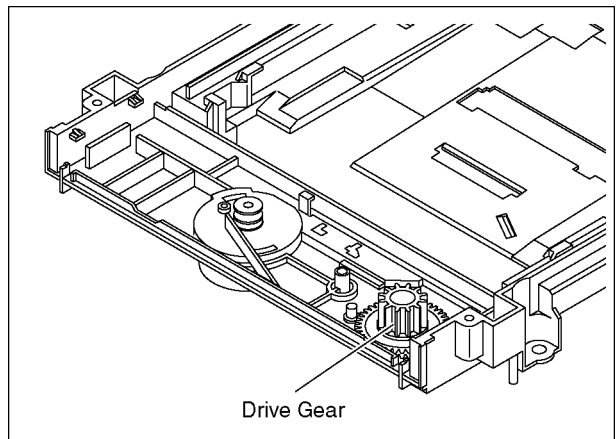

3. Remove the 2 soldering points and 2 Hooks, and remove the Loading Motor.

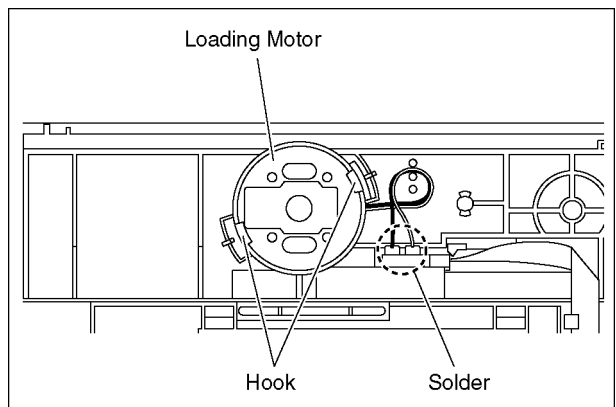

**Note: (When attaching)**

1. Align the projection with the hole of the Loading Motor and attach.
2. Fix the lead as below.
3. Fix each FFCs by 2 Hooks (A) and 1 Hook (B).

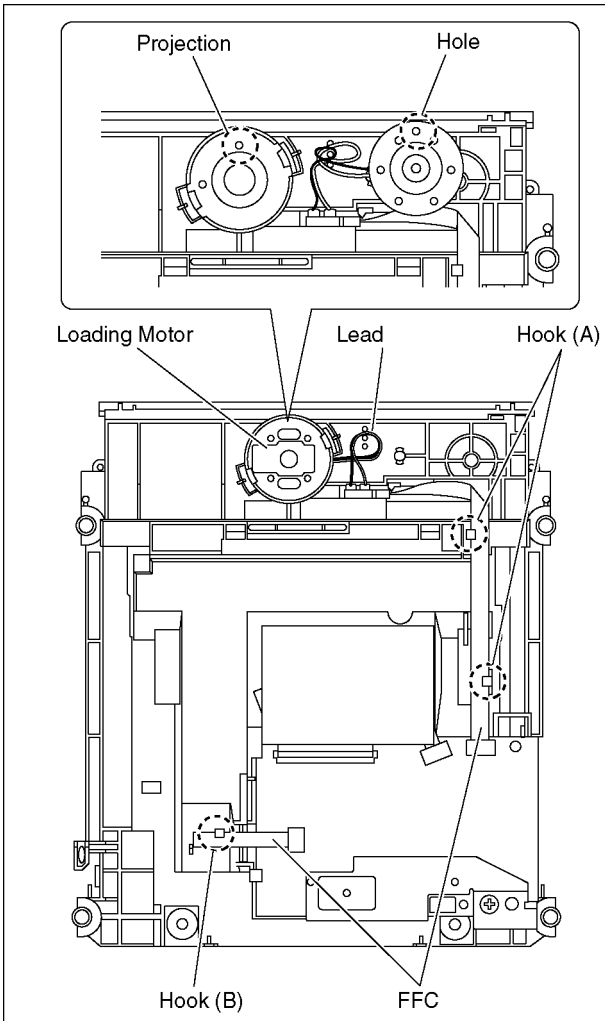

4. When attaching the tray, slide the Slide Cam to the right until it can be.

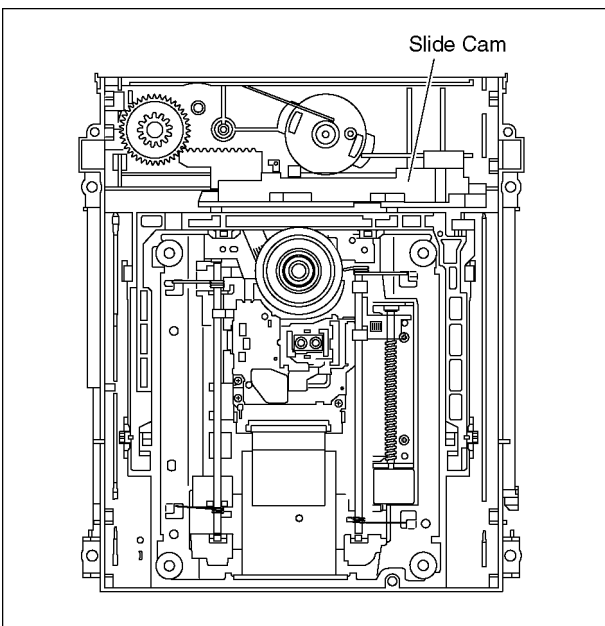

## 9.2.6. Grease

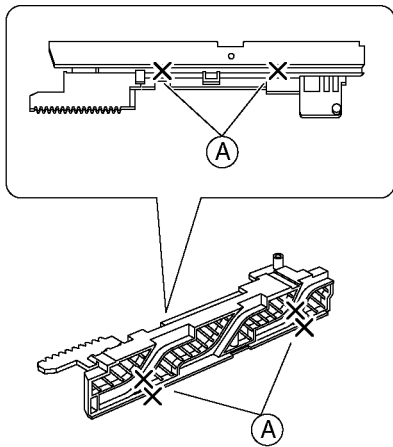

(Up side of the Tray)

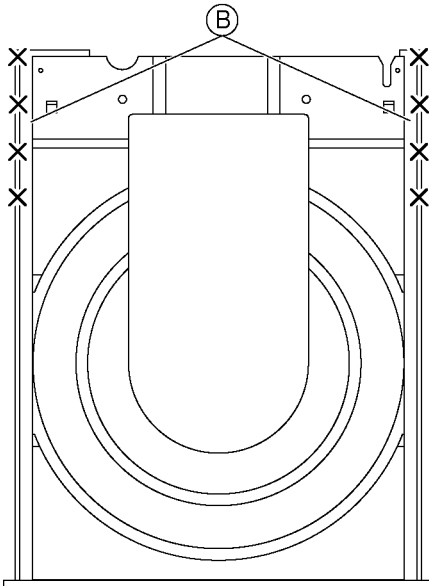

(Back side of the Tray)

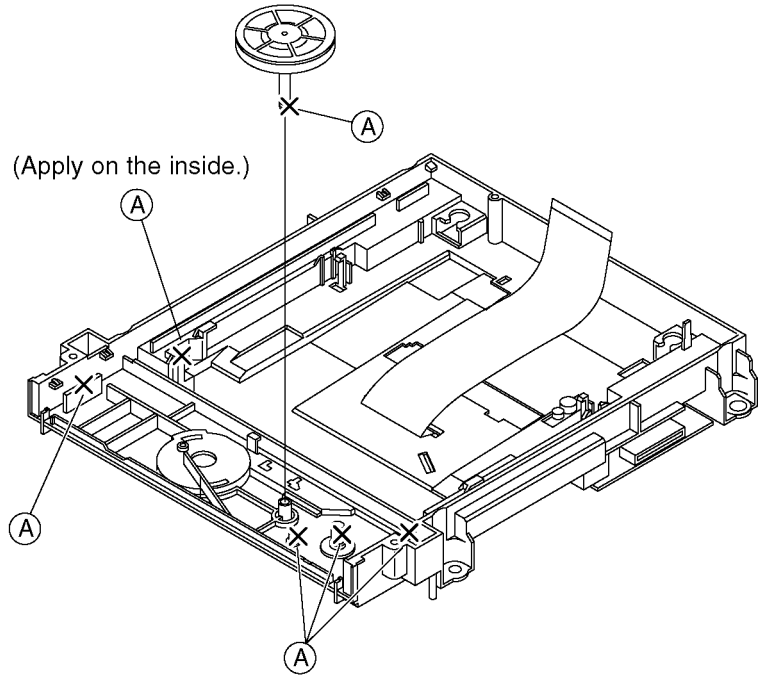
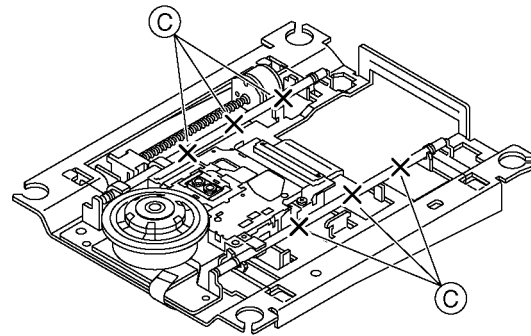
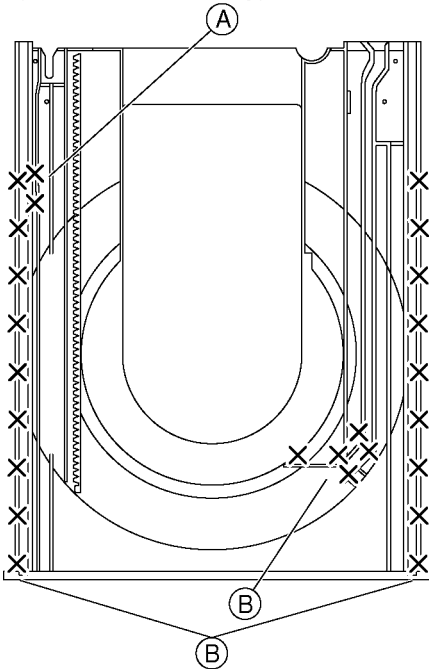

### LUBRICATION POINTS

When the marked parts are replaced, apply the recommended lubricants for better maintenance of the unit.

Mark	Kind of lubricant	Part No.
Ⓐ	Grease	RFKZ0484
Ⓑ	Hanarl	RFKZ0441
Ⓒ	Grease	RFKZ0472

### 9.2.7. How to Clean the Lens of Optical Pick-UP

Follow the "9.2.1. Upper Base Ass'y"

Caution :  
Be sure to wipe a lens in the direction of arrow.  
Wiping a lens in the opposite direction may cause damage to the OPU.

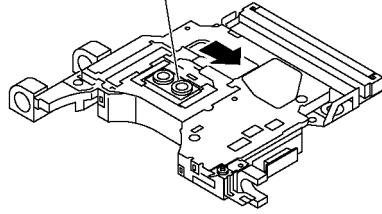

Gently wipe the object lens surface with a cotton swab slightly dampened with ethyl alcohol. Clean the lens until the cotton swab no longer picks up dirt. Finally, wipe the lens surface with a soft, dry cloth to remove any residual alcohol.

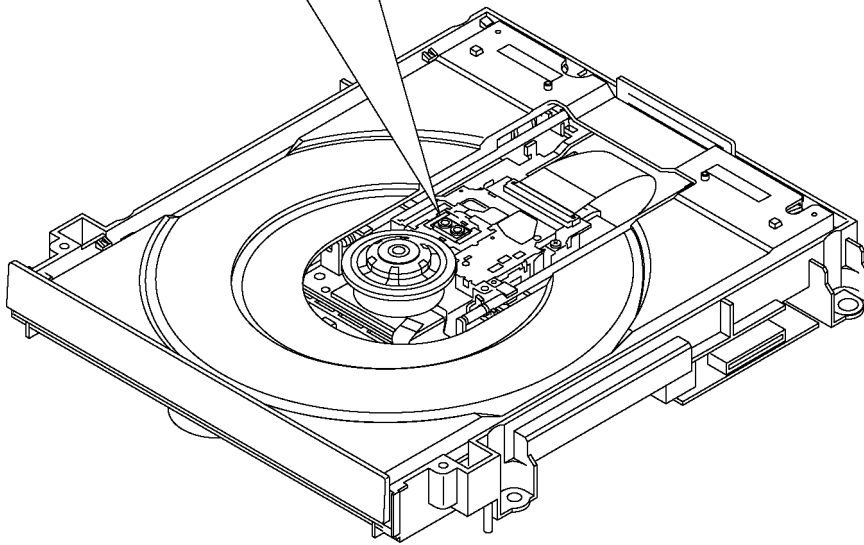

**Service hint**

If a defective phenomenon is "NO READ", please try to clean TT (turn table) in the drive in according to the following procedure.

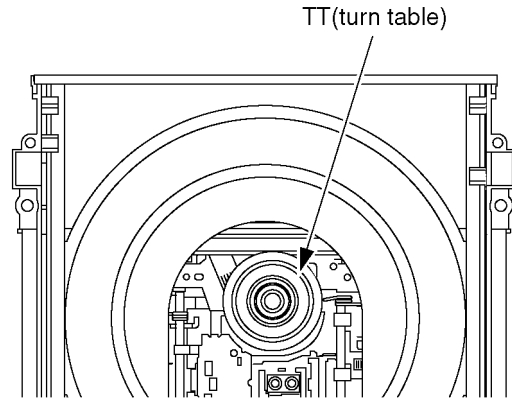

1. Blow off dust on TT by a blower. (Air must not blow to it strongly.)

Caution: Move outside to protect OPU.

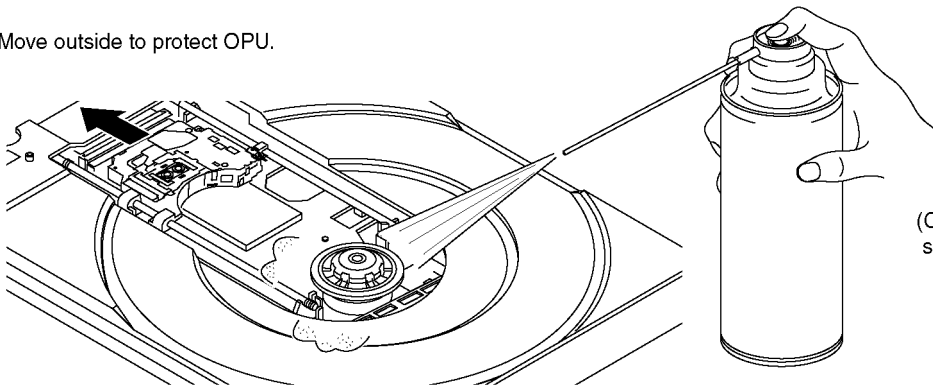

2. Apply one drop of ethyl alcohol or isopropyl alcohol on a clean cotton swab.  
(Always use a fresh cotton swab free from any additive or chemical.)

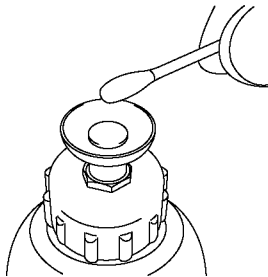

3. Lightly put the cotton swab on TT, and wipe it by turning by your finger.  
(Don't touch the surface of TT when you turn it.)

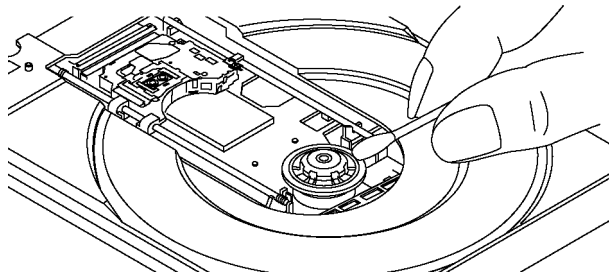

# 10 Measurements and Adjustments

## 10.1. Service Positions

**Notes:**

1. For description of the disassembling procedure, see the section 9.
2. In this document, explanations basically use illustrations of DMR-UBS90EG.  
In other models, shape of some parts may be different.

### 10.1.1. Checking and Repairing of Main P.C.B.

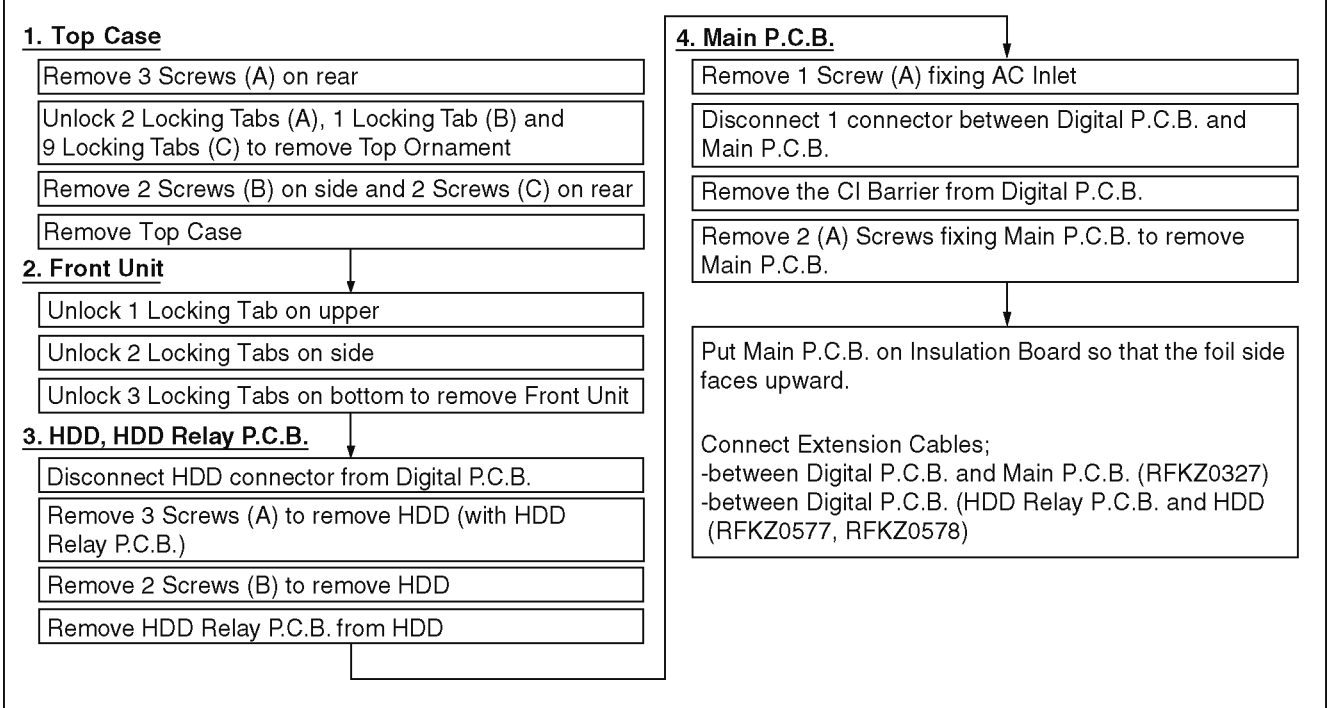

**Caution:**  
Red wire in the extension cable should be connected to (1) pin.

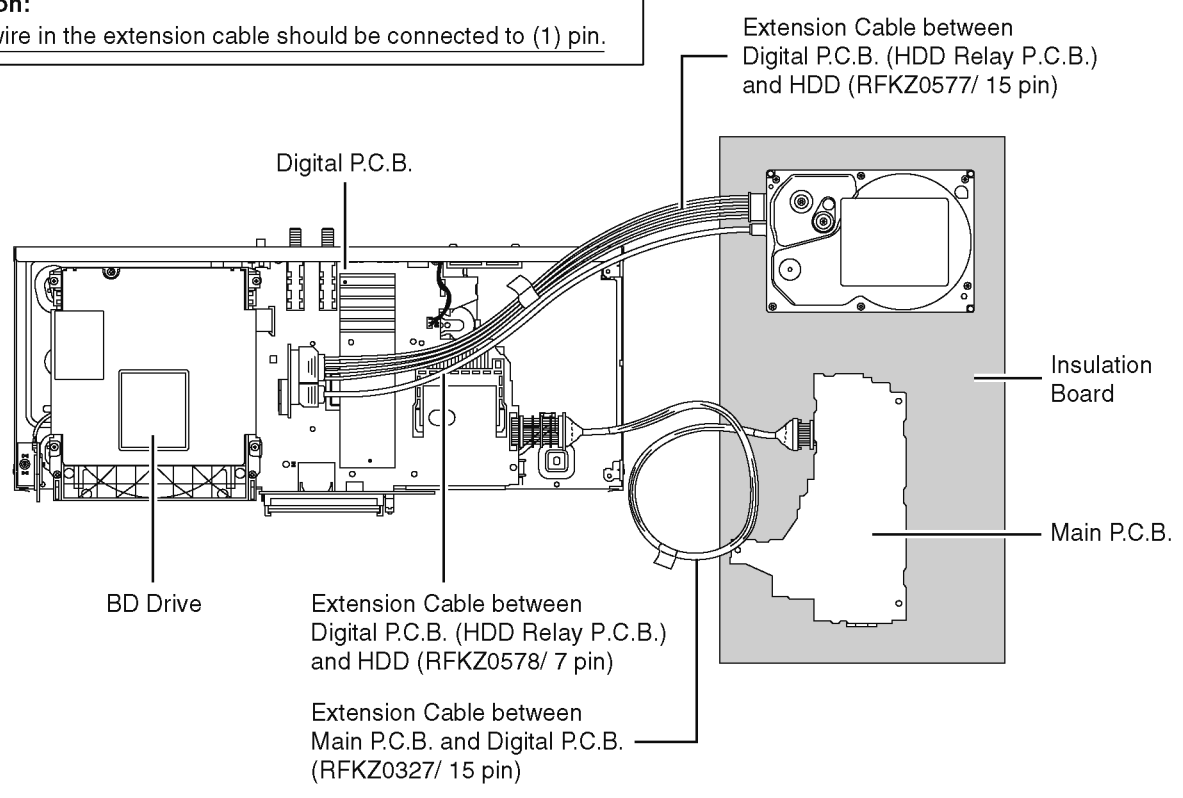

## 10.1.2. Checking and Repairing of Digital P.C.B.

### 1. Top Case

Remove 3 Screws (A) on rear

Unlock 2 Locking Tabs (A), 1 Locking Tab (B) and 9 Locking Tabs (C) to remove Top Ornament

Remove 2 Screws (B) on side and 2 Screws (C) on rear

Remove Top Case

### 2. Wi-Fi Module

Remove 1 Screw (A) and disconnect WLAN Cable connector

Remove Wi-Fi Module

### 3. Front Unit

Unlock 1 Locking Tab on upper

Unlock 2 Locking Tabs on side

Unlock 3 Locking Tabs on bottom to remove Front Unit

### 4. BD Drive

Disconnect Drive FFC form Digital P.C.B.

Remove 4 Screws (A) to remove BD Drive

### 5. Rear Panel

Remove 3 Screws (A) and 2 Screws (B) fixing Rear Panel (UBS80EG)

Remove 3 Screws (A) and 4 Screws (B) fixing Rear Panel (UBS90EG)

Disconnect DC Fan Motor connector, unlock 2 Locking Tabs on side and remove Rear Panel

### 6. HDD, HDD Relay P.C.B.

Disconnect HDD connector from Digital P.C.B.

Remove 3 Screws (A) to remove HDD (with HDD Relay P.C.B.)

Remove 3 Screws (B) to remove HDD

Remove HDD Relay P.C.B. from HDD

### 7. Digital P.C.B.

Remove 2 Screws (A) fixing Digital P.C.B.

Disconnect 1 connector between Digital P.C.B. and Main P.C.B. to remove Digital P.C.B.

Put Digital P.C.B. and Wi-Fi Module on Insulation Board.  
Connect DC Fan Motor Connector to Digital P.C.B.  
Connect WLAN Cable to Digital P.C.B.  
Connect HDD Relay P.C.B. to Digital P.C.B.

Connect Extension FFCs, Cables;  
-between Digital P.C.B. and Main P.C.B. (RFKZ0327)  
-between BD Drive and Digital P.C.B. (SUKZ000007)  
-between Digital P.C.B. (HDD Relay P.C.B.) and HDD (RFKZ0577, RFKZ0578)

### Caution:

Red wire in the extension cable should be connected to (1) pin.

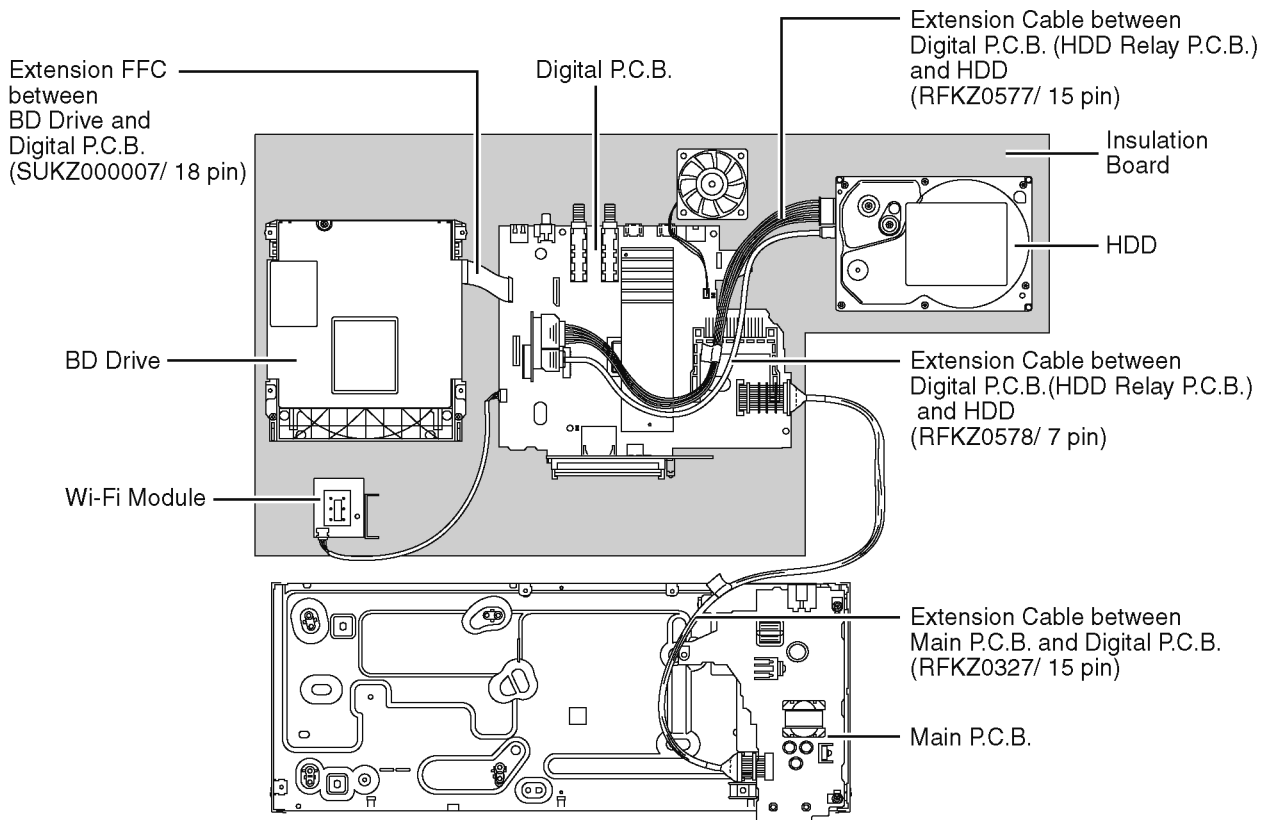

## 10.2. Caution for Replacing Parts

### 10.2.1. Items that should be done after replacing parts

✓ : Necessary

— : Unnecessary

Replacing Parts	Items that Should be done	Main Firm update (*Note)	HDD Format
Digital P.C.B.	✓	—	—
Main P.C.B.	—	—	✓
IC6811 (EEPROM)	—	—	✓
HDD	—	—	✓

**\* Note:**

Download latest Firmware and burn it on CD-R or CD-RW, and update Firmware.

### 10.2.2. Notice after replacing Digital P.C.B. or BD Drive

Formatting the HDD is unnecessary after replacing Digital P.C.B. or BD Drive.

[TM AV1] is displayed, once power OFF, and power ON again.

## 10.3. Standard Inspection Specifications after Making Repairs

After making repairs, we recommend performing the following inspection, to check normal operation.

No.	Procedure	Item to Check
1	Turn on the power, and confirm items pointed out.	Items pointed out should not reappear.
2	Insert RAM disc.	The Panasonic RAM disc should be recognized.
3	Enter the EE (TU IN / AV IN - AV OUT) mode.	No abnormality should be seen in the picture, sound or operation.
4	Model with the HDD: Perform self-recording and playback for one minute using the HDD.	No abnormality should be seen in the picture, sound or operation.
5	Perform copy a program to disc and playback for one minute using the BD-RE (V2.0) and RAM discs.	No abnormality should be seen in the picture, sound or operation. *Panasonic BD-RE (V2.0) and DVD-RAM discs should be used when copying and playback.
6	If a problem is caused by a VCD, DVD-R, DVD-Video, Audio-CD, or MP3, playback the test disc.	No abnormality should be seen in the picture, sound or operation.
7	Models with SD Card Slot or USB Input Jack: In case of that the trouble is caused by SD card and / or USB terminal.	Models with SD Card or USB Input Jack; 1) SD Card: Check to be able to display and copy the picture. 2) USB terminal: Check to be able to display and copy the picture.
8	After checking and making repairs, upgrade the firmware to the latest version.	Do not turn the power off until writing is complete (The tray automatically opens when writing is complete.). "NoUPDATE" message indicates that updating the version is not necessary since the version is the latest or the same one.
9	Transfer [9][9] in the service mode setting, and initialize the service settings (return various settings and error information to their default values. The laser time is not included in this initialization).	Make sure that [CLR] appears in the FL display. After checking it, turn the power off.

Use the following checklist to establish the judgement criteria for the picture and sound.

Item	Contents	Check	Item	Contents	Check
Picture	Block noise		Sound	Distorted sound	
	Crosscut noise			Noise (static, background noise, etc.)	
	Dot noise			The sound level is too low.	
	Picture disruption			The sound level is too high.	
	Not bright enough			The sound level changes.	
	Too bright				
	Flickering color				
	Color fading				



# 11 Block Diagram

## 11.1. Overall Block Diagram

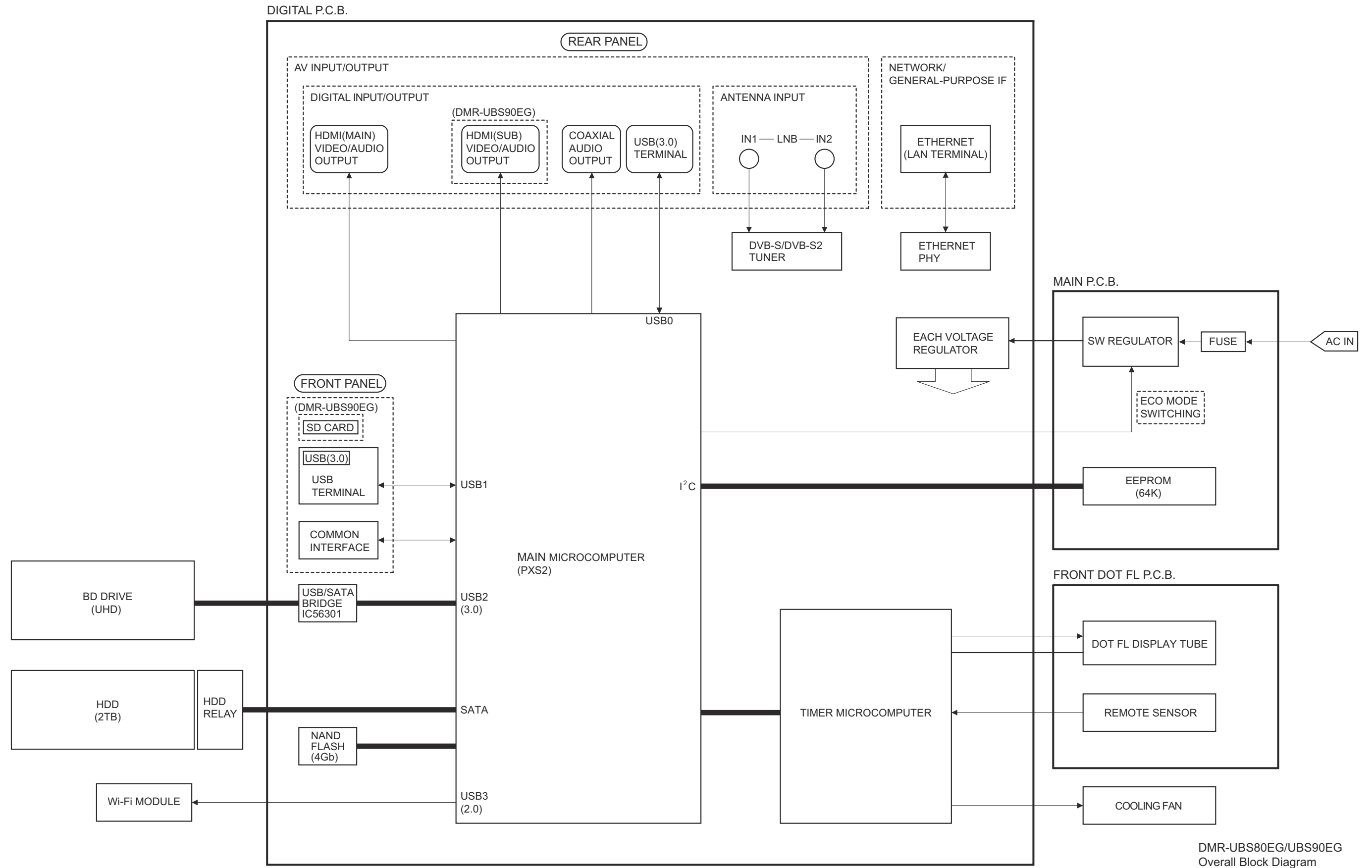

DMR-UBS80EG/UBS90EG  
Overall Block Diagram

# 11.2. Power Supply Block Diagram

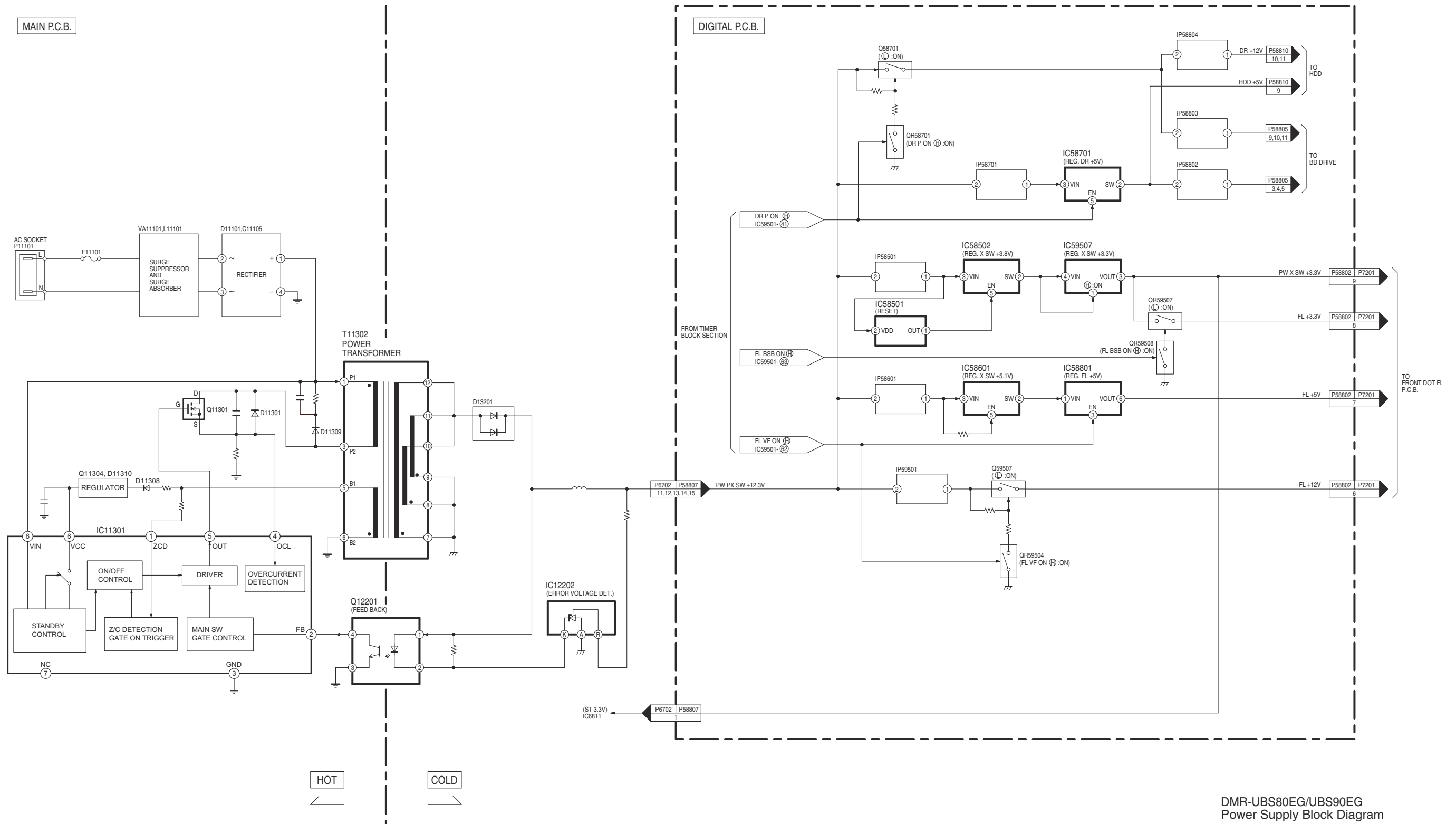

DMR-UBS80EG/UBS90EG  
Power Supply Block Diagram

### 11.3. Timer Block Diagram

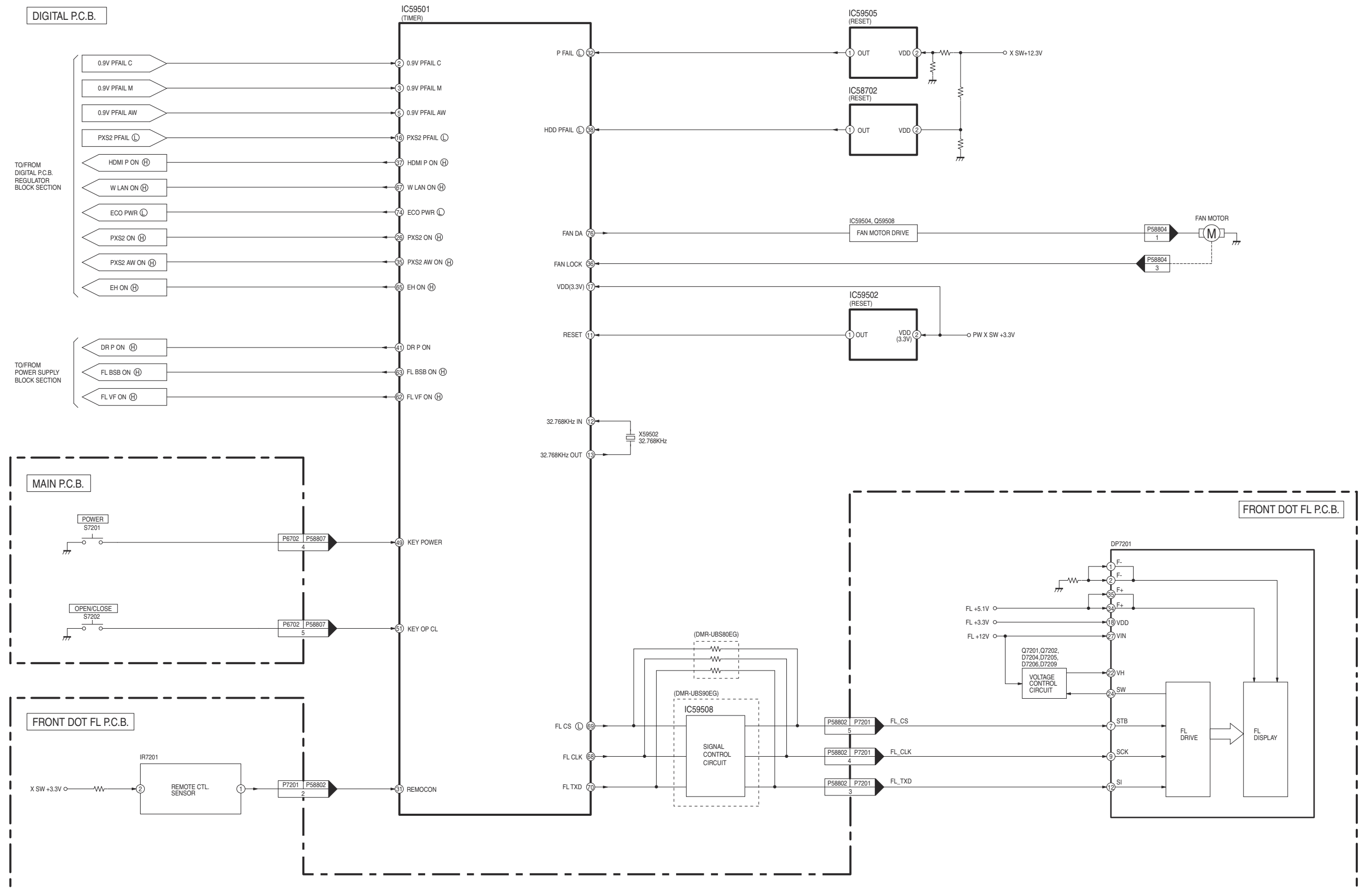

DMR-UBS80EG/UBS90EG  
Timer Block Diagram



# 11.5. Digital Block Diagram (1/2)

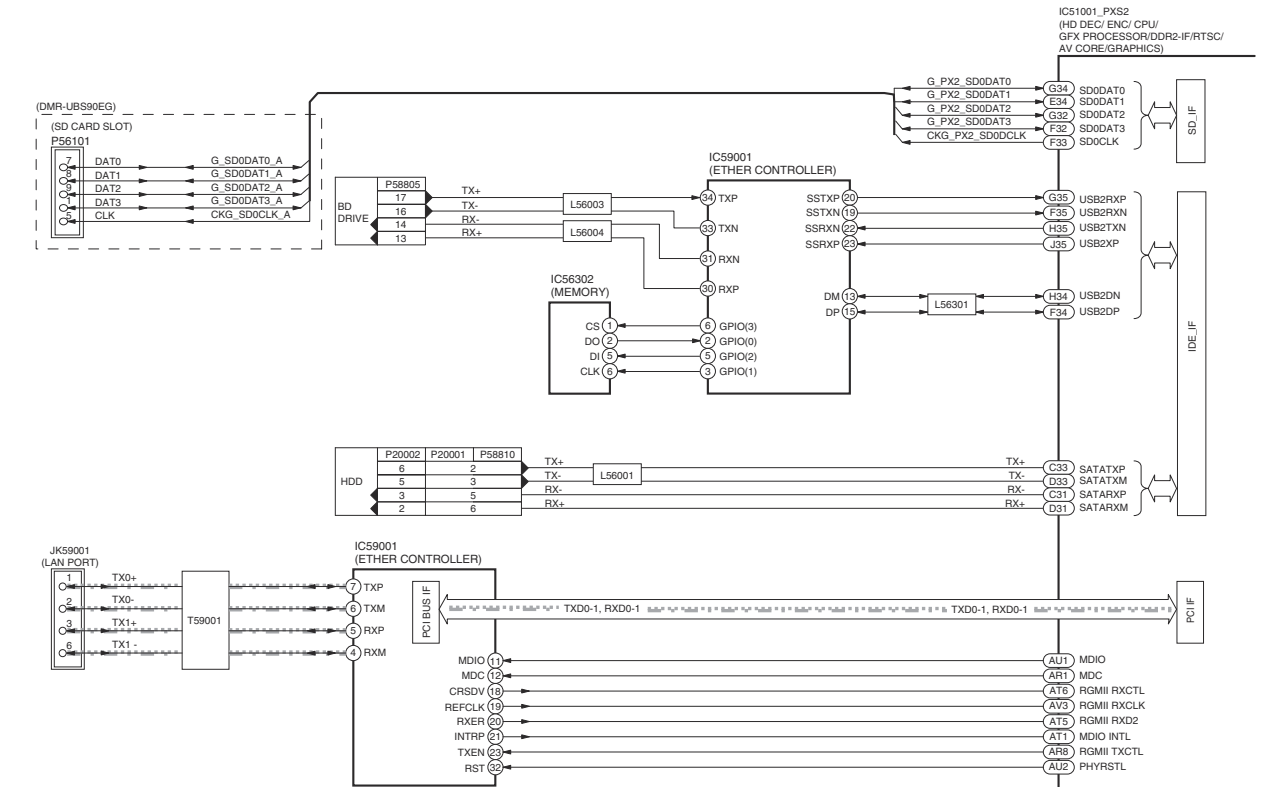
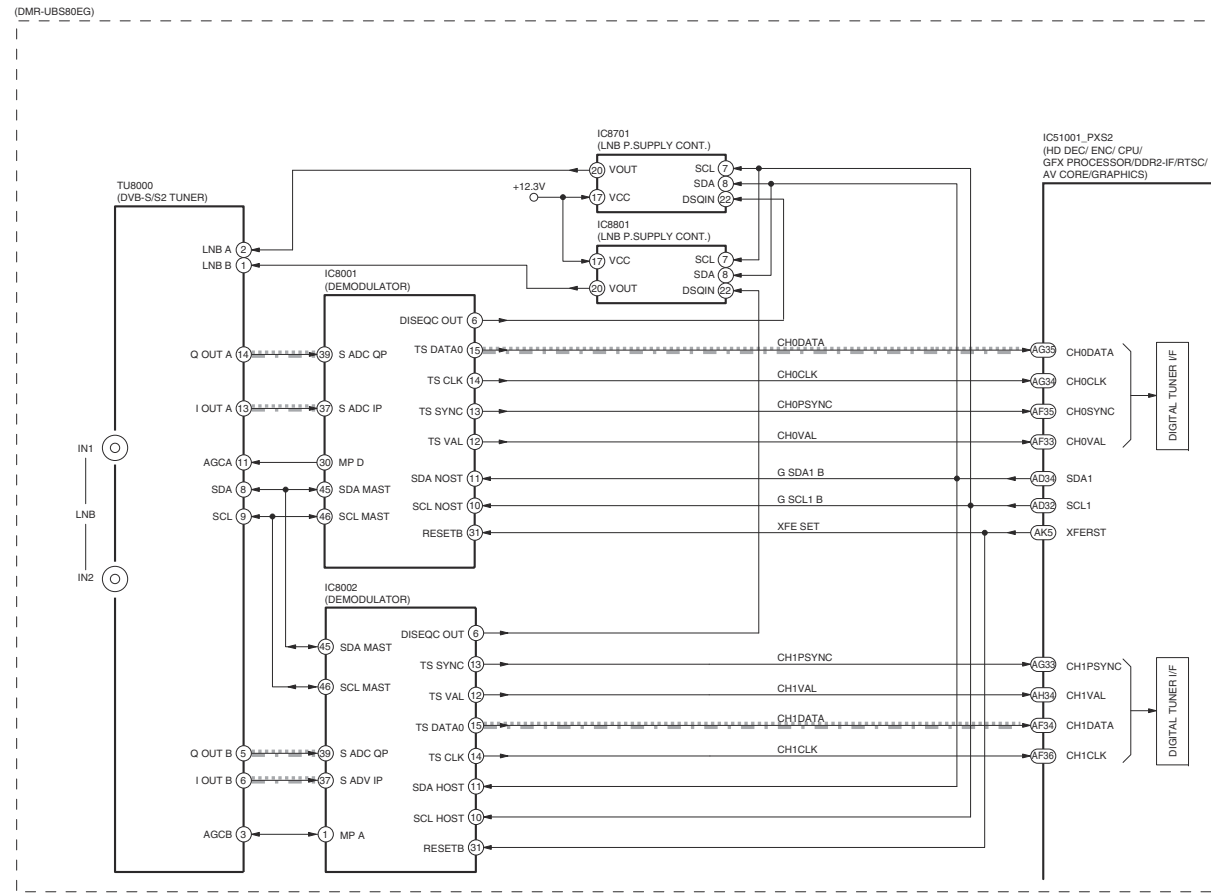

- VIDEO REC SIGNAL
- VIDEO EE SIGNAL
- VIDEO PB SIGNAL
- AUDIO REC SIGNAL
- AUDIO EE SIGNAL
- AUDIO PB SIGNAL

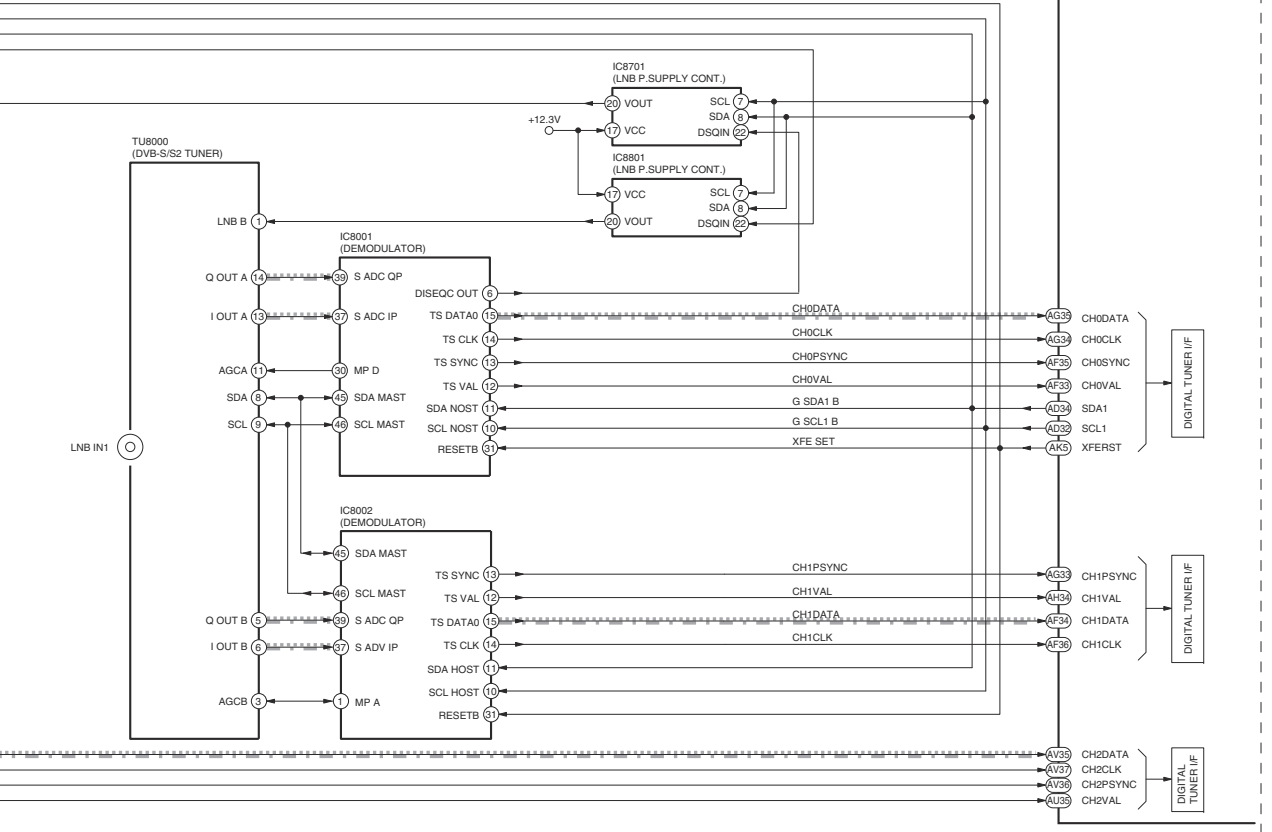
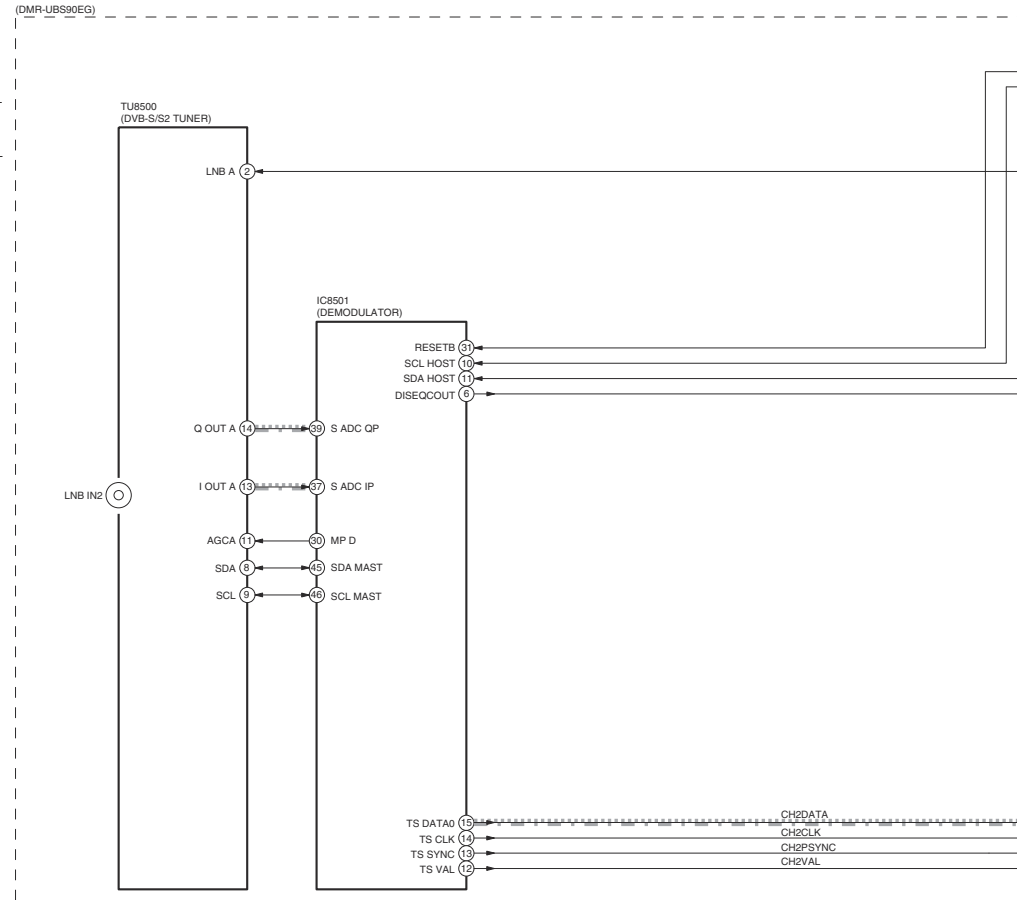

DMR-UBS80EG/UBS90EG  
Digital Block Diagram (1/2)

# 11.6. Digital Block Diagram (2/2)

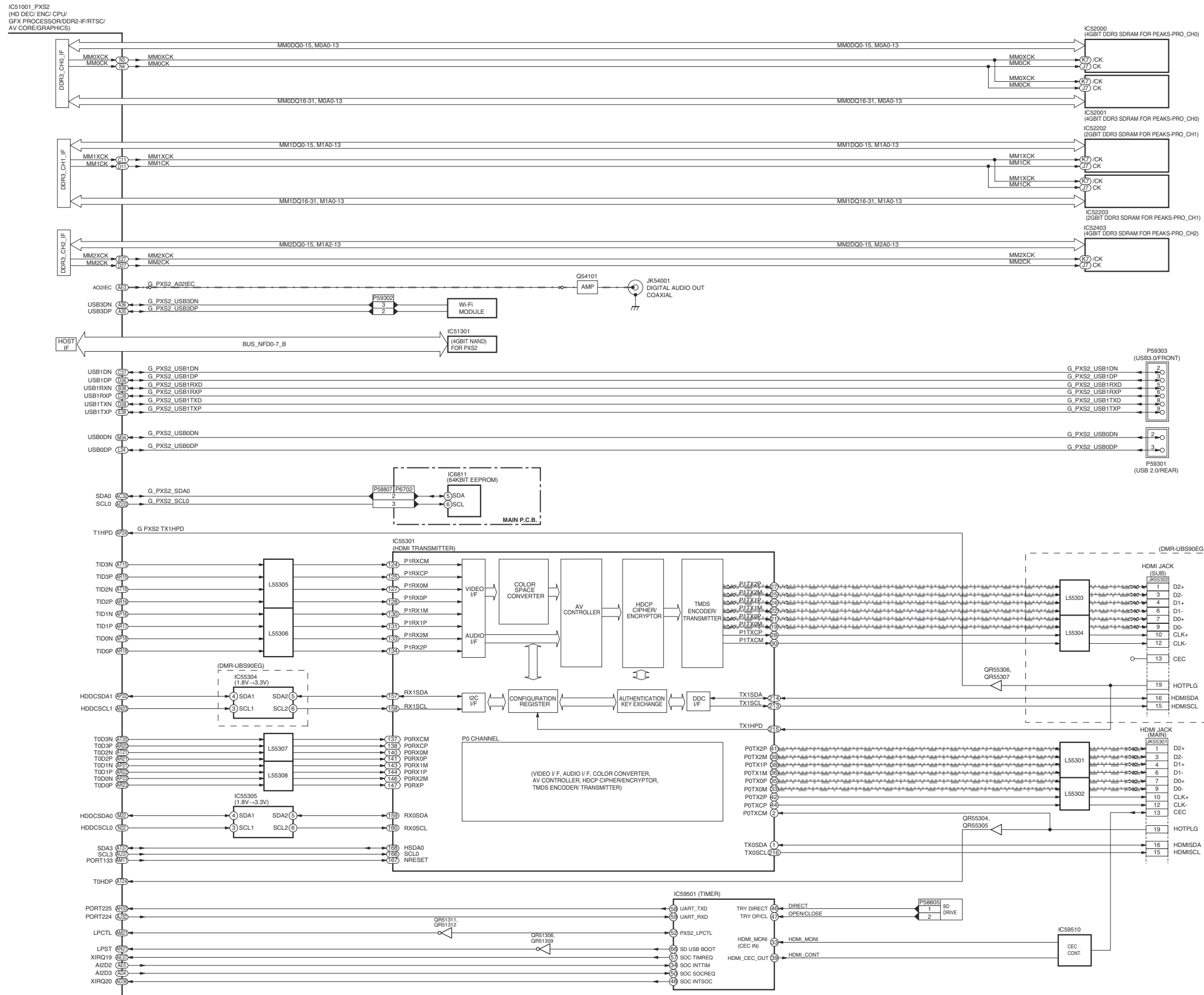

DMR-UBS80EG/UBS90EG  
Digital Block Diagram (2/2)

# 11.7. CI Block Diagram

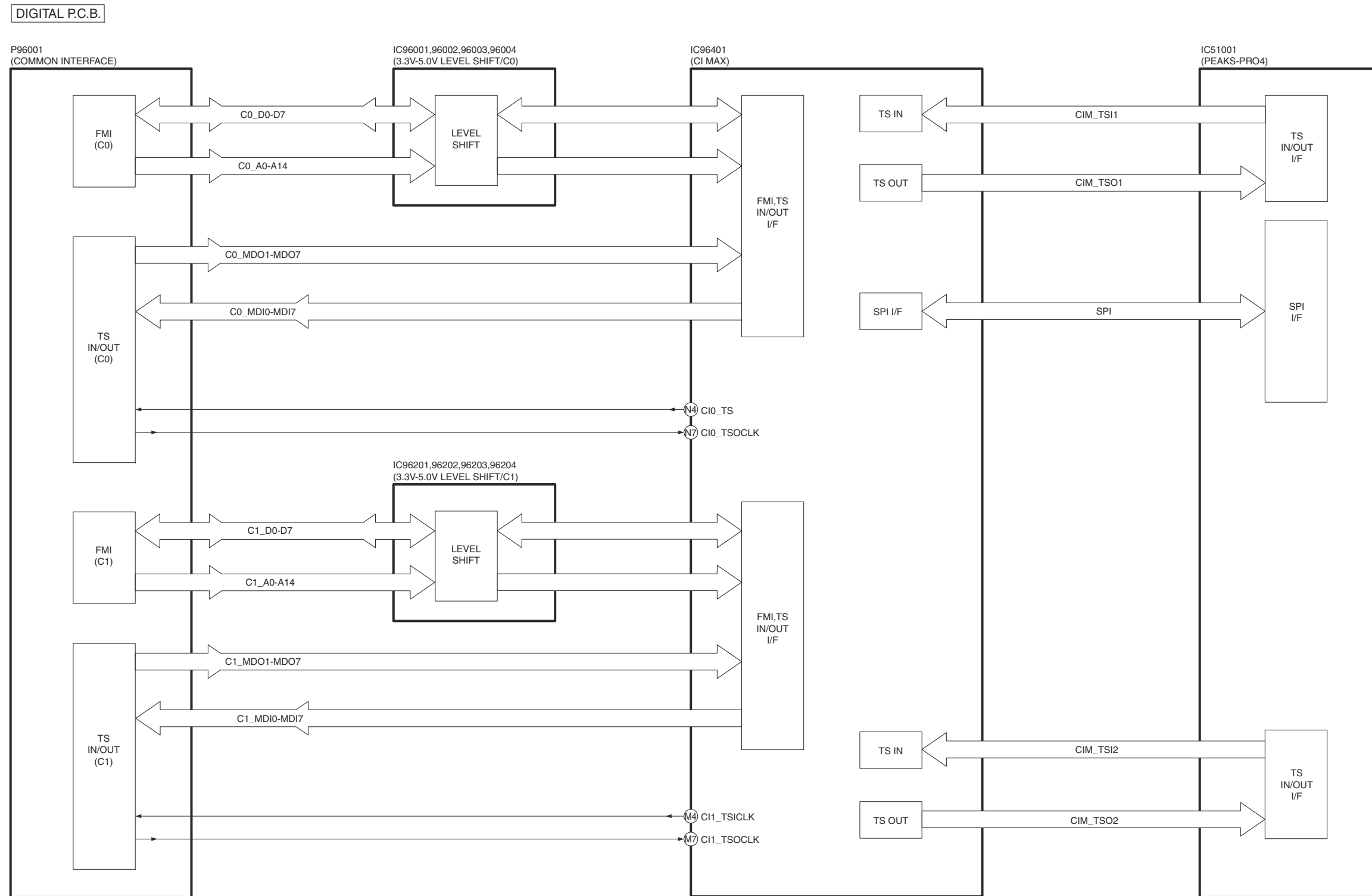

DMR-UBS80EG/UBS90EG  
CI Block Diagram

# 12 Wiring Connection Diagram

## 12.1. Interconnection Schematic Diagram

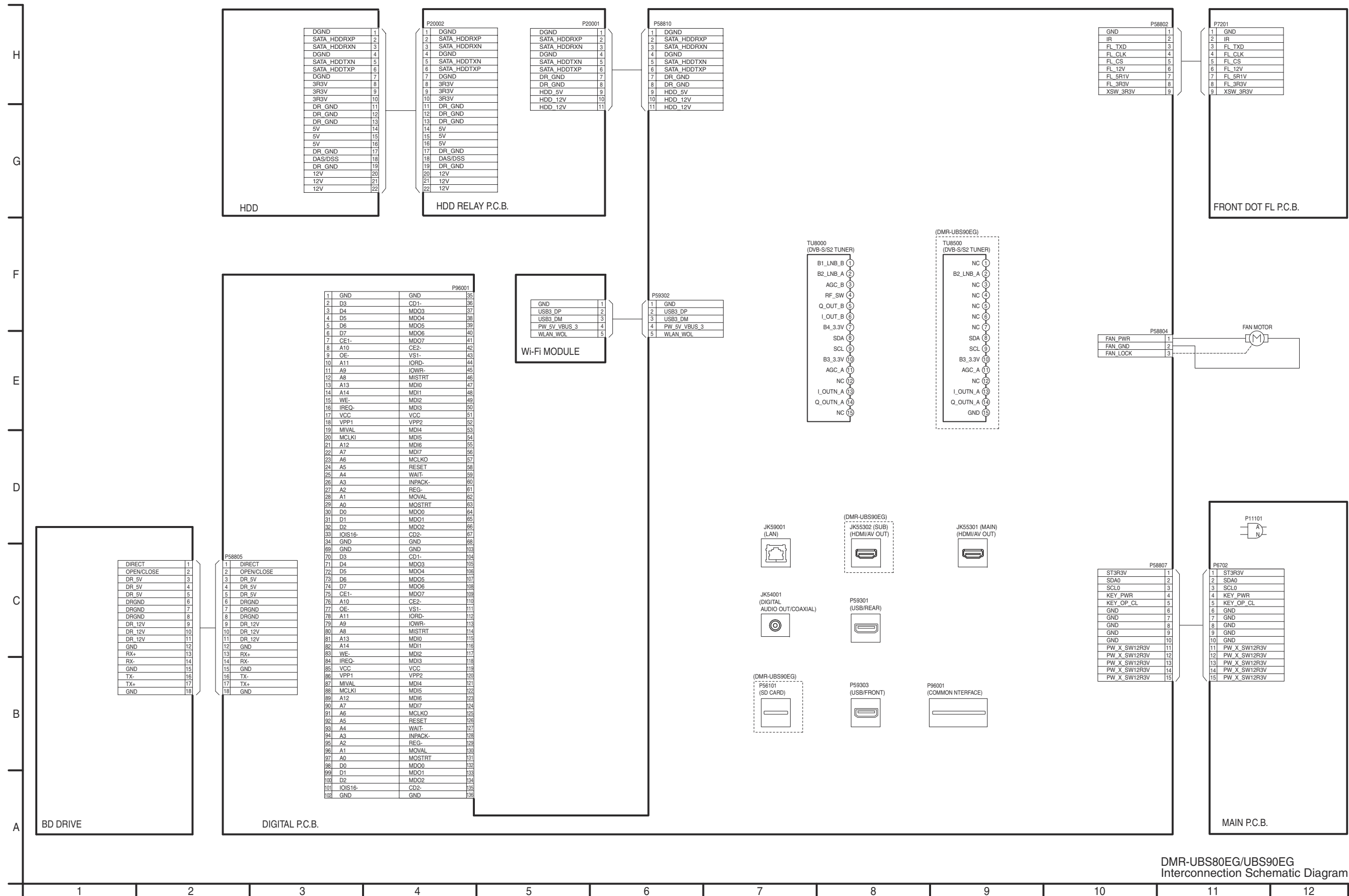

DMR-UBS80EG/UBS90EG Interconnection Schematic Diagram

## **13 Schematic Diagram**

Please click the radio button for "Diagrams II / Parts List" on the menu bar in XML Service Manual.  
If you want to print, please click the icon button for "Print" on the icon bar and select the item.

## **14 Printed Circuit Board**

Please click the radio button for "Diagrams II / Parts List" on the menu bar in XML Service Manual.  
If you want to print, please click the icon button for "Print" on the icon bar and select the item.

## **15 Exploded View and Replacement Parts List**

Please click the radio button for "Diagrams II / Parts List" on the menu bar in XML Service Manual.  
If you want to print, please click the icon button for "Print" on the icon bar and select the item.