

AFTER  
SALES  
SERVICE

**FAGOR**



# TECHNICAL STUDY

*technical*  
**Documentation**

**PRODUCT:**

Induction Hobs

**RANGE:**

Innova 2004

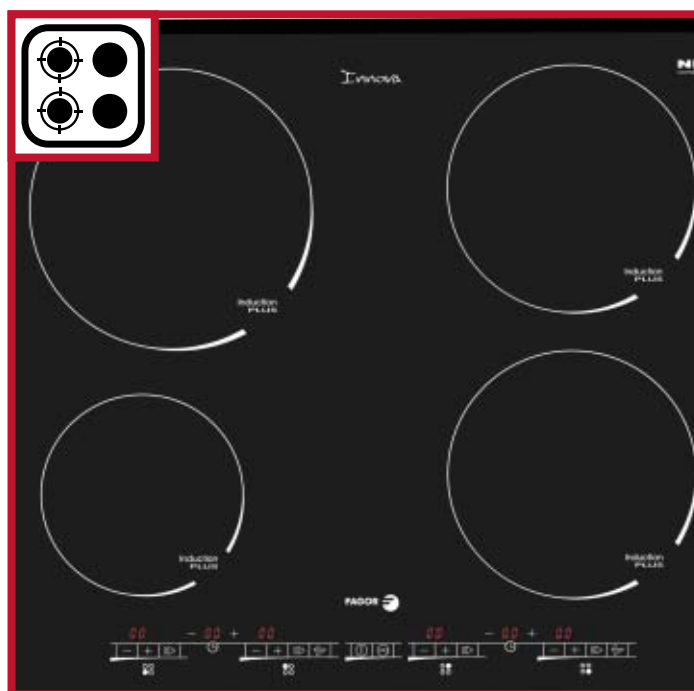

**Date: 18/05/2004**

**Document N°: 5245**



This document is for use by all persons providing technical assistance service (T.A.S.). It is an aid for repairing the product described, and provides back-up documentation for technical consultations.

The following safety warnings are given in this manual:

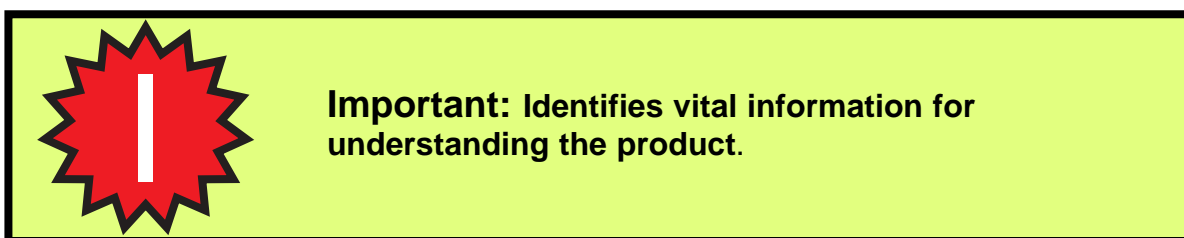
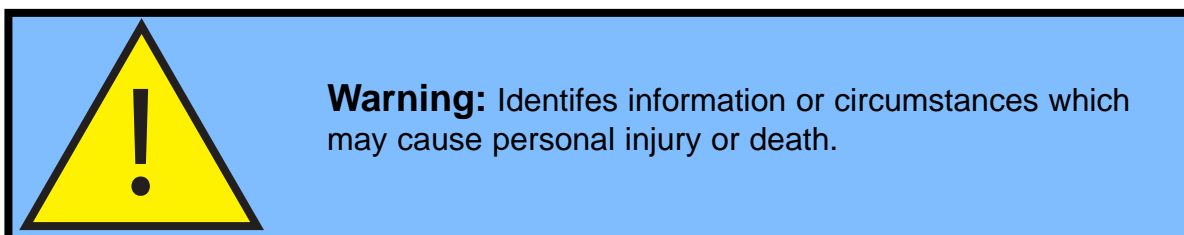
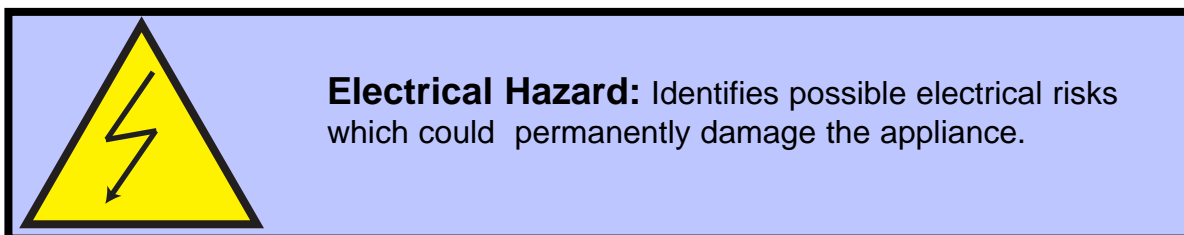

© Copyright by Fagor Electrodomésticos S. Coop. 2002. All rights reserved. The total or partial reproduction of this document, using any type of procedure or on any type of support, is prohibited without previous written authorisation by the owner of the trading rights. Persons failing to comply with this reservation will be pursued under the applicable legislation and may be prosecuted.

FAGOR ELECTRODOMÉSTICOS reserves the right to introduce any modifications to the characteristics of its products, without prior notice.

<b>1.- Warnings and precautions .....</b>	<b>1</b>
<b>2.- Features .....</b>	<b>3</b>
<b>3.- Description of functioning .....</b>	<b>5</b>
3.1.- General description .....	5
3.2.- Troubleshooting.....	18
3.3.- Assembly and disassembly instructions .....	27

---



## Sensors

The Touch hob has a control circuit which reacts when you touch it with your finger, and also if a reflecting object is brought close to it, as it functions by infra-red rays.

The sensors must be kept clean. Do not place any objects on them, as the appliance could interpret this as an order.



If a button on the Touch control selector is pressed for longer than 10 seconds, the whole hob will be switched off.

## Child safety

The hob has a safety button which locks the control to prevent any “unwanted” orders from being given.

## Note

It is normal for the hob glass to heat up slightly. This is caused by the heat of the pan itself.



### **TO THE ATTENTION OF CARDIAC PACEMAKER AND ACTIVE IMPLANT USERS:**

The hotplate complies with current electromagnetic interference regulations.

This induction hob fully complies with all legal requirements (EEC directives 89/336). It is designed not to interfere with the functioning of other electrical appliances, providing they comply with the same regulation.

### **THIS INDUCTION HOB GENERATES MAGNETIC FIELDS.**

Your pacemaker must be designed in compliance with the corresponding regulations in order for no interference to be caused between it and the hotplate. Consult the pacemaker manufacturer or your doctor to determine whether it complies with the regulations in force or whether any incompatibilities exist.

## 2.- Features

### Advantages of the hob

In comparison with classic hobs, the induction hob is:

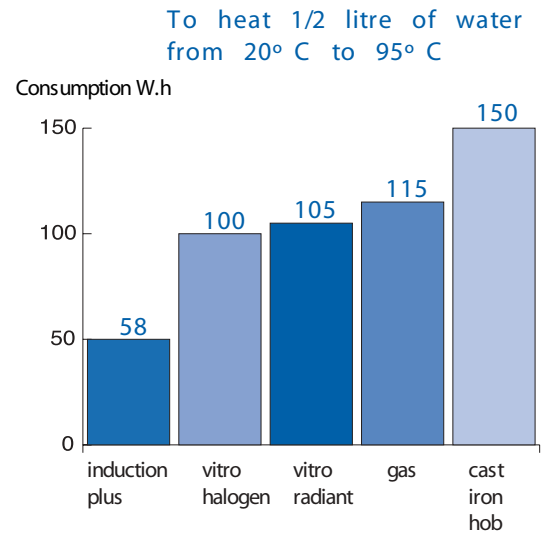
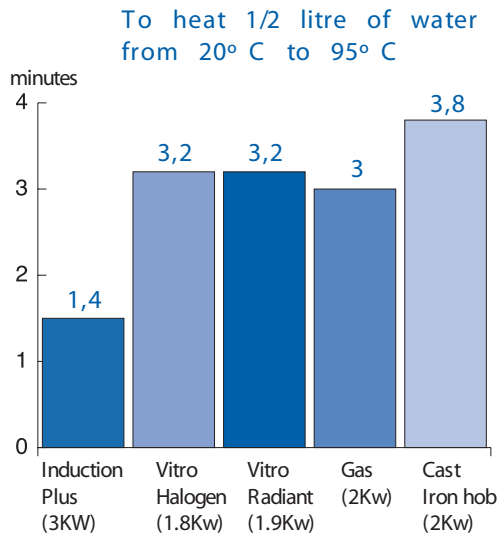

### Quicker

The hob's greater power makes it much quicker than a normal electric or gas hob.

### More accurate

It is quicker to use and it reacts instantly to the indications given. Adjust it finely if you wish - it will react perfectly.

### Safer

The induction principle means that the heat is produced directly, exactly where the pan is. The temperature of the glass is lower and there is less risk of burns, particularly for children.

### More economical

The pan itself closes the circuit and makes the hob function. If there is no pan, no energy is used.

If there are no pans on the burners, the burners will not heat up. The power indicator lights will flash on and off.

It consumes much less energy than hobs with classic gas or electric burners.

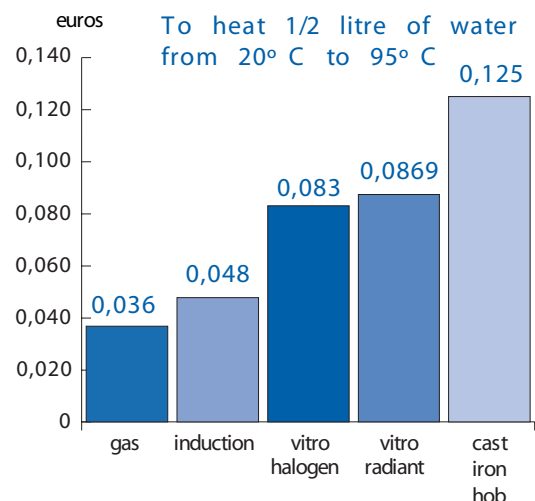

The vitro-ceramic hob is supplied with a power cable. If the power cable is damaged in any way it must be replaced by the manufacturer or after-sales service or by authorised personnel, to avoid hazard.

If the mains supply where the hob is to be installed is different from 220...240V~, make the connection as shown in the enclosed diagrams. (The cable must be able to withstand temperatures of 120°).

It must be connected to the mains at a socket complying with EEC publication 7 or a single-pole cut-off device with a contact opening distance of at least 3 mm.

Total power:

High range 4/3I hob:  
7.2kW

900 wide hob:  
10.8 kW

300 wide hob:  
3.6 kW

Mixed induction hob:  
6.1 kW

HOB	THREE-PHASE			THREE-PHASE A		
	Voltage	Nominal power per ring	Protection	Voltage	Nominal power per ring	Protection
2 induction	220...240V	15,6A	20A	220...240V	9A	10A
4induction low	220...240V	24,5A	32A	220...240V	14A	16A
2+2 mixed	220...240V	26,5A	32A	220...240V	15,5A	16A
3/4 induction high	220...240V	31,5A	32A	220...240V	18A	20A
5 iinduction	220...240V	47A	50A	220...240V	27A	32A

**230 V.2**

N L PE

**230 V.3**

L1 L2 L3 PE

HOB	THREE-PHASE			THREE-PHASE A		
	Voltage	Nominal power per phase	Protection	Voltage	Nominal power per phase	Protection
2 induction	380...400V	15,6A	20A	220...240V	9,5A	16A
4induction low	380...400V	8,5A	10A	220...240V	15A	16A
2+2 mixed	380...400V	9,5A	10A	220...240V	16A	20A
3/4induction high	380...400V	11A	16A	220...240V	19A	20A
5induction	380...400V	16,5A	20A	220...240V	28A	32A

  

**380 V.3N**

N L1 L2 PE

**380 V.2N**

N L1 L2 PE

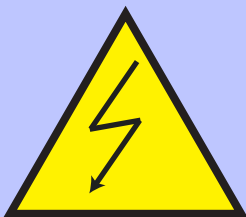

If the mains is 380 or 400V triphase and if the phase switching is not simultaneous, make sure the neutral wire is connected first when the line is energised. When turning off the voltage, disconnect the neutral wire last. These precautions will also protect the other electronic appliances. The manufacturer is not liable in case of any accidents occurring and their eventual consequences if an induction hob is used without first being earthed, or if it has a defective earth connection.

## 3.- Description of functioning

### 3.1.- General description

The heat needed to cook the food is produced directly inside the pan. The hob itself hardly heats up at all: it only receives heat from the pan. If the pan boils over or any splashes are caused, these will not harden or become baked onto the glass. Stains can easily be removed with a damp cloth or damp kitchen paper, or with a bathroom cleaning sponge.

Any splashes or liquids that have boiled over should be cleaned straight away. Check that they have been completely removed before using the hob again.

Some tips:

- For stubborn stains, use a few drops of a light cream-type cleaning product. To remove hard water stains, use a few drops of white spirit vinegar.
- For stubborn stains on the metal, products such as Zip, Johnson's or Ppz for stainless steel can be used.
  
- After cleaning always rinse with water and dry with absorbent kitchen paper.
  
- The use of abrasive products or scouring powders (Vim, Bref, Ajax, steel scouring pads or abrasive sponges such as Green Scotch Brite) is not advisable as they could scratch the hob.
  
- Never use products containing ammonia.
  
- Although the glass part of the hob is resistant to friction from pans, in the long term this may wear down the pattern on the vitro-ceramic burners. However, hard materials such as grit from dried vegetables could cause scratching to the hob.
  
- Such appearance defects do not affect the hob's functioning in any way and are not covered by the guarantee.
  
- If the hob breaks, splits or cracks, even slightly, this will be visible on the glass. Disconnect the appliance from the mains immediately and contact the after-sales technical service.

## Precautions when fitting the hob

Be extremely careful to observe the following points:

- Work surface edges close to the hob must be heat-resistant.
- Laminate coatings and their fixing glue must be heat-resistant, to avoid deterioration.
- The ventilation space located behind and under the hob makes it more reliable as it guarantees cooling however the hob is fitted.
- Never install the hob on top of a dishwasher, washing machine, refrigerator or freezer.
- It must have Y-type overheating protection in accordance with IEC regulations 335-2-6.
- The hob must fit correctly into the work surface.

The dimensions of the hole to be cut for fitting the induction hob are:

<b>For a three- or four-burner hob</b>	
Depth	49 cm
Width	56 cm

- We recommend that a specialist in electrical appliances installs this material. The hob is provided with a seal to ensure it fits correctly into the work surface and is hermetically sealed. Be careful not to damage this seal, and take care when placing the hob in the opening.

## Installing the hob

- Ensure that the surface in which the induction hob is to be fitted is perfectly even. Any deformations caused by incorrect positioning of the hob could alter the appliance's ability to function.
- The wood chipboards used in manufacturing the work surface swell relatively quickly when they come into contact with damp. Apply a varnish or special paste to the edges to protect them from any steam or drops of condensation which could come off the work surface.
- Ensure that there is sufficient air flow in the cabinet. (Overheating protection: type Y in accordance with regulation EN 60.335.2.6).

## Installation area

### 1.- Cutting the cupboard

Fire protection degree: type "X" appliance.

**Important:** There must be a minimum distance of 100 mm between the hole and the wall or adjoining cupboard.

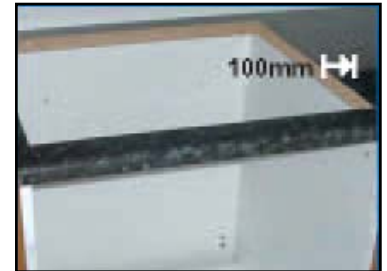

### 2.- Place of installation

**Above a drawer:** The electronic circuits of the induction hob must be cooled by a current of fresh air as shown in the diagram, and the points listed below must be carefully complied with.

The greater the distance between the hob and the cupboard underneath it, the better the hob will function.

**Important:** Your induction hob needs an air inlet at the rear and an air outlet at the front.

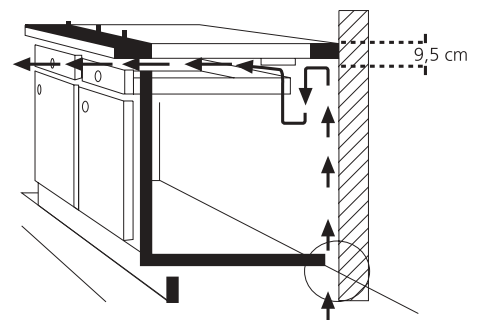

**Above a cupboard with a door:** For hobs which have an air vent underneath the hotplate.

a) Optimum installation: leave an air outlet space between the hob and the door. With a small crossbar there are no particular difficulties.

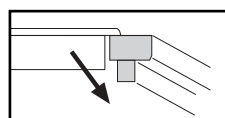
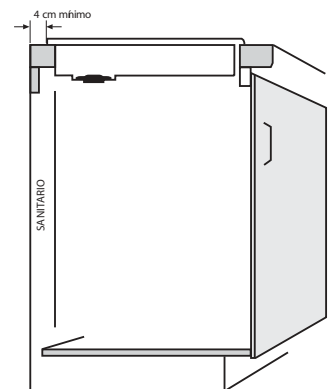

b) With a rectangular crossbar or a closed top bar, make a bevelled cut to free the air vent.

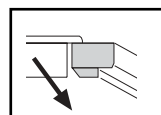
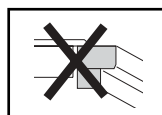

c) When the thickness of the work surface is over 30 mm or an extension is used to rest the hotplate on, the ventilation cover should be rotated as shown in the figures below:



**Above an oven:** The hotplate can be directly fitted above an oven of the same brand.

This oven has an upper ventilation system and can therefore be installed in a high position.

Remove the front crossbar of the cabinet to leave a free space of at least 9 mm.

**Important:** Your induction hob must NOT be installed above a dishwasher, washing machine, refrigerator or freezer.

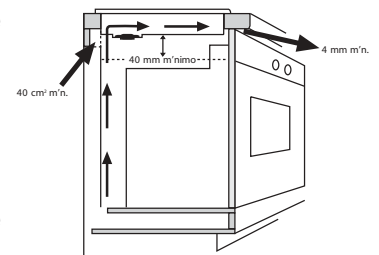

### 3.- Preparing the hotplate

a) Place the hob face down on a table.

b) Remove the adhesive paper and stick the seal provided with the appliance all around the hob.

**Important:** If your hob does not have a frame, you should first stick the strips shown in the figure to the hob, and then adapt the straight strips to these.



**When installing induction hotplates, the instructions given here must be followed in order for the appliance to function correctly. The appliance may be seriously damaged if these ventilation instructions are not observed.**

## Description of type A hobs

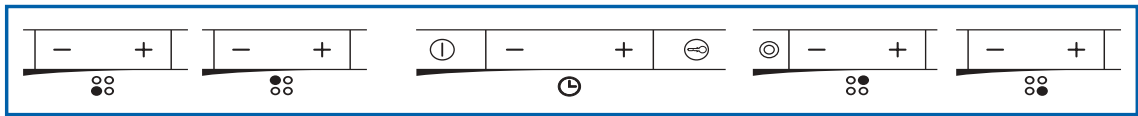

### Ring indicators:

These show the location of each ring on the hob.



### Power displays:

These show the power setting each ring is working on.

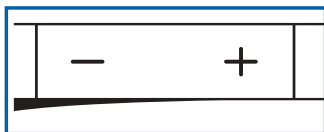

### Residual heat indicator:

An H lights up on the power display to indicate that a particular ring is very hot and should not be touched. It may remain on up to approximately 30 minutes, depending on the power setting selected.

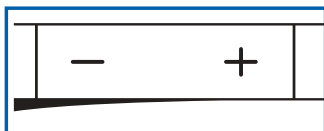

### Power sensors:

For selecting the power setting of the rings, from 0 to 9.

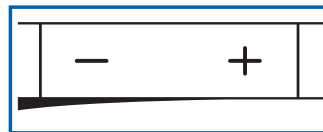

**Double ring sensor and display:** For activating the outer part of the double ring and viewing its functioning.



### On/off sensor:

Allows the hob to be switched on and off directly without using any other sensors.



### Safety sensor and display:

Allows the other sensors to be blocked to prevent children playing with them, and their functioning to be viewed.

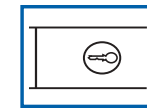

### Timer sensors:

For setting a cooking time of between 0 and 99 minutes on the selected ring.

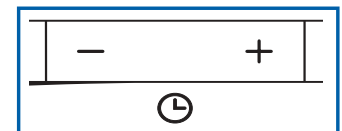

### Timer display:

For viewing the cooking time on the ring selected.

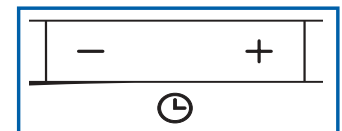

## Type A functioning

### 1.- Using the touch control

Switching on a ring

a) Place your fingertip on the on/off sensor. Remember there is a safety sensor to prevent children from playing with the controls, which is deactivated by leaving your fingertip on the control for three seconds.

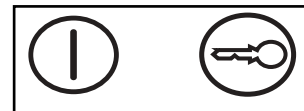

b) Make sure you touch the sensor corresponding to the ring you wish to use.

Place your fingertip on – or + to switch on the ring.

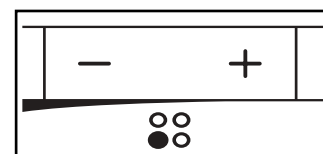

c) Select the desired power setting by leaving your finger on the control.

d) To work the double ring (only available on MIXED hobs), place your fingertip on its sensor.



e) To switch off the ring, press both the - and + buttons down at the same time with two fingers.

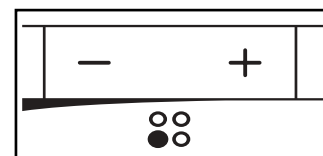

#### Important:

- If all the rings are turned off, the hob will switch off in a few seconds and H will light up to indicate which rings are still hot.
- You can activate the safety sensor whenever you wish by holding your fingertip on the sensor for three seconds.
- If any objects are left on the sensors, the hob will beep several times and then switch off.
- The hob will automatically switch off after an estimated safety time, which varies depending on the power setting chosen. (From 1 hour on setting “P” or “9”, to 10 hours on setting “1”).

When liquids are being boiled, some noise will be heard due to the ring frequencies connecting, particularly on high settings.

## 2.- Timer function

a) Place your fingertip on the + or - timer sensors. The display will light up showing 00 or 99, and a letter “t” will appear on the ring power displays.

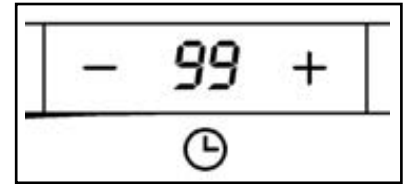

b) Then place your fingertip on the + or - power sensor of the ring you wish to apply the timer to, selecting the power setting you wish it to function at. The display of the selected ring will flash alternately between the power setting chosen and t.

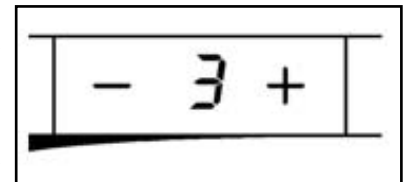

**Important:** If no ring is selected the timer will switch off.

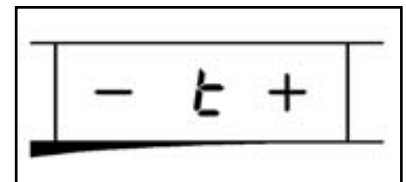

c) Select the time required using the + and - timer sensors. The time selected will appear on the timer display and the ring will be programmed.

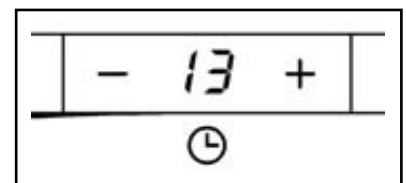

**Important:** If no time is selected and the display shows 00, the timer will switch off. If the display shows 99, 99 minutes will be selected on the timer.

d) While the ring is functioning with its timer setting, the display will flash alternately between the power setting chosen and t. When the selected time has elapsed, the ring will switch off and a beep will sound, until one of the sensors receives a signal.

### 3.- Using the automatic quick heating programmer

Each control zone is equipped with automatic programmed functioning. This programming allows the corresponding maximum temperature to be rapidly reached and the ring then goes to maintenance temperature. All this takes place automatically. The programming procedure is as follows:

a) Place your fingertip on the “+” power sensor of the radiant ring you wish to programme, until the display shows “9” for the radiant rings and “P” for the induction rings. If you continue working the sensor the display will show “9.” or “P.”.

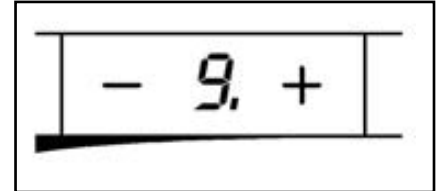

b) You then have 10 seconds to select the desired power setting by pressing the “-” power sensor until the display shows this setting, as a number followed by a decimal point (“3.”).

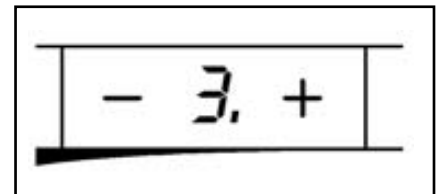

c) After the automatic heating time has elapsed, you will hear a short beep and the decimal point after the number shown on the display will disappear. The ring will continue to function conventionally.

If you wish to cancel the automatic programming, place your fingertip on the “-” sensor and the decimal point will disappear.

**Important:** If you are using the automatic heating programming for an induction ring, the ring on the same side of the hotplate should not be switched on, as this will cancel out the automatic heating.

## Description of type B hobs

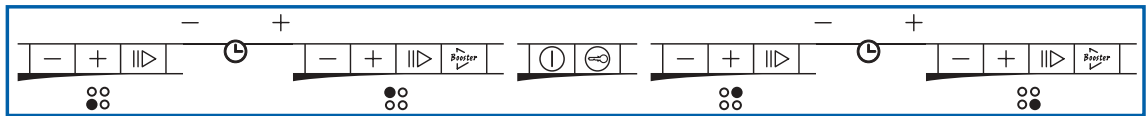

### Ring indicators:

These show the location of each ring on the hob.



### Power displays:

These show the power setting each ring is working on.

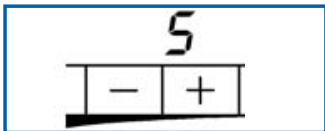

### Residual heat indicator:

An H lights up on the power display to indicate that a particular ring is very hot and should not be touched. It may remain on up to approximately 30 minutes, depending on the power setting selected.

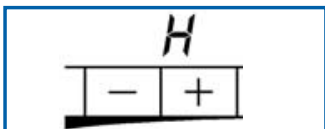

### + and - sensors:

These are for selecting the power setting of the rings, from 0 to 11.



### Direct access sensors:

These allow the ring to be turned directly to setting 8 at any time.

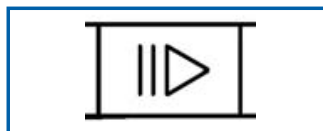

### BOOSTER sensor:

This allows the ring to be turned directly to the maximum setting (on some rings only)



### On/off sensor:

Allows the hob to be switched on and off directly without using any other sensors.



### Safety sensor and display:

Allows the other sensors to be blocked to prevent children playing with them, and their functioning to be viewed. When the sensor block is activated, none of the other buttons can be activated. This will be indicated on the whole of the touch control.

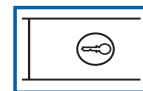

### Timer sensors:

For setting a cooking time of between 0 and 99 minutes on the selected ring.

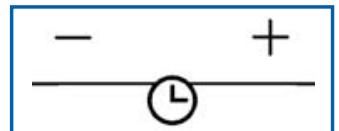

### Timer displays:

For viewing the cooking time on the ring selected.

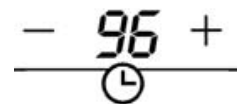

## 1.- Using the touch control

### Switching on a ring

a) Place your fingertip on the on/off sensor. Remember there is a safety sensor to prevent children from playing with the controls, which is deactivated by leaving your fingertip on the control for three seconds.

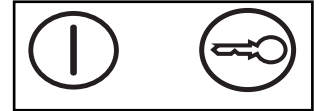

b) Make sure you touch the sensor corresponding to the ring you wish to use.

Place your fingertip on – or + to switch on the ring.

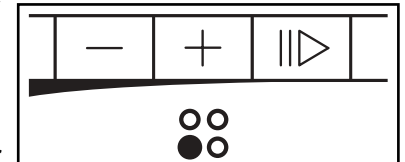

c) Select the desired power setting by leaving your finger on the control.

d) To switch off the ring, press the - and + buttons down with two fingers at the same time.

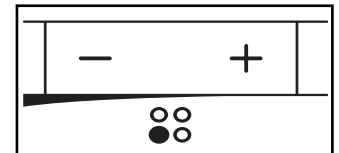

### Important:

- If all the rings are turned off, the hob will switch off in a few seconds, and H will light up to indicate which rings are still hot.
- You can activate the safety sensor whenever you wish by holding your fingertip on the sensor for three seconds.
- If any objects are left on the sensors, the hob will beep several times and then switch off.
- The hob will automatically switch off after an estimated safety time, which varies depending on the power setting chosen. (From 1 hour on setting “P” or “11”, to 10 hours on setting “1”).

When liquids are being boiled, a noise will be heard due to the ring frequencies connecting, particularly on high settings.

## 2.- Timer function

a) The timers may be used with the rings located to the left and right of the timer, except the specific timer for the extra-large ring (depending on the model). The same number of rings can be programmed simultaneously as the number of timers on the hob (1, 2 or 3, depending on the model).

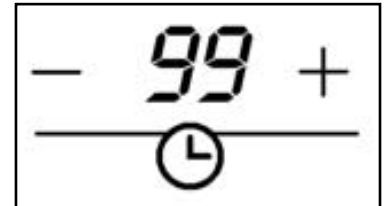

b) Place your fingertip on the + or - timer sensors. The display will light up showing 00 or 99.

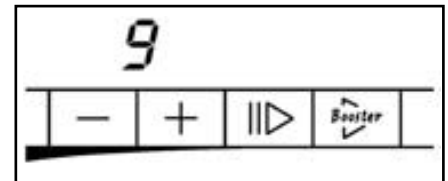

c) Then place your fingertip on any sensor corresponding to the ring you wish to set with the timer. A red LED to the right of the selected power display will light up to confirm it is being timed. Choose the desired power setting using the + and - buttons for the ring.

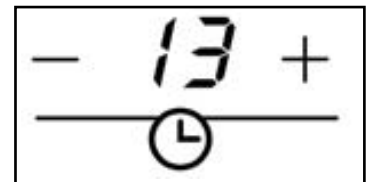

**Important:** If no ring is selected the timer will switch off.

d) Select the time required using the + and - timer sensors. The time selected will appear on the timer display and the ring will be programmed.

**Important:** If no time is selected and the display shows 00, the timer will switch off. If the display shows 99, 99 minutes will be selected on the timer.

e) When the selected time has elapsed, the ring will switch off and a beep will sound until one of the sensors receives a signal. The power display for the ring switched off will flash.

### 3.- BOOSTER function

Some of the cooking zones are equipped with a BOOSTER function, which takes the ring to its maximum temperature by heating at maximum power for 10 minutes and then switching to maintenance temperature. All this takes place automatically. The programming procedure is as follows:

a) Select the power setting you wish to maintain the cooking zone at, after quick heating with the BOOSTER function.

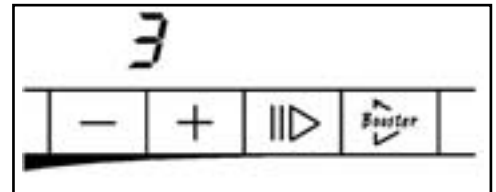

b) Press the BOOSTER button. The ring power display will show the message "Bo" and the ring will begin to heat up to the maximum setting for as long as necessary.

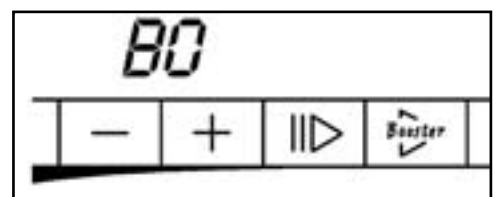

c) After the heating time has elapsed, you will hear a short beep and the power display will show the maintenance setting selected. The ring will continue to function conventionally.

If the "+" power sensor is activated when the BOOSTER function is working, the selected maintenance setting level will increase.

The BOOSTER function is cancelled out by pressing any other power sensor for the ring in question, or with the on/off sensor.

**Important:** If you are using the BOOSTER function you should not switch on the ring on the same side of the hotplate, as this will cancel it out.

#### Using the P (PLUS) and BOOSTER settings

a) The power needed for each two induction rings is obtained using a 2800/3600W power generator. Each generator shares its power between two rings.

**Important:** If the sum of the power settings selected exceeds this value, priority will be given to the last command given. You can prevent this happening by using rings on opposite sides.

b) If you are not using the P or BOOSTER settings on a ring, you can use the ring on the same side as normal. You can therefore use the four rings at the same time up to setting 9, if you wish. The above restriction is therefore a rare occurrence.

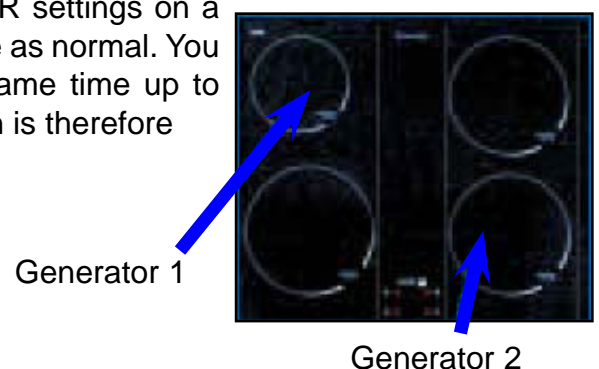

**Power tables**

**Type A**

Sum of rings on one side 2800 W.

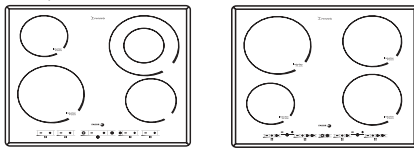

**Type B**

Sum of rings on one side 3600 W.

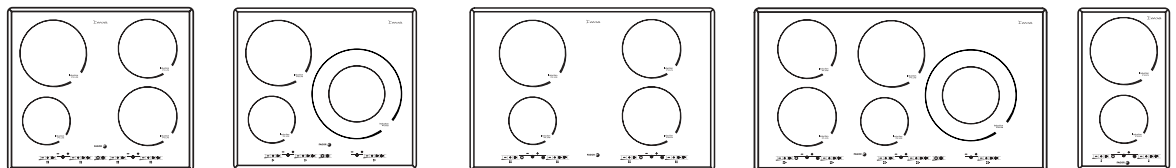

		INDUCTION HIGH RANGE				INDUCTION LOW RANGE			RADIANT	
DIAMETER		145	180	210	280	145	180	210	145	210
P O S I T I O N	1	75	100	100	120	100	100	100	38	66
	2	150	200	200	240	200	200	200	76	133
	3	225	300	300	360	300	300	300	170	300
	4	300	400	400	480	400	400	400	225	395
	5	400	500	500	600	500	500	500	300	522
	6	500	700	700	840	600	700	700	375	655
	7	600	900	900	1080	800	900	900	545	952
	8	700	1100	1100	1320	1100	1500	1500	765	1342
	9	800	1300	1300	1560	1300	1900	1900	1200	2100
	10	1000	1550	1600	1920	-----	-----	-----	-----	-----
	11	1200	1800	1900	2280	-----	-----	-----	-----	-----
P	1600	2100	2200	2640	1600	2800	2800	-----	-----	
BOOSTER	-----	2800	3000	3600	-----	-----	-----	-----	-----	

**Setting restrictions**

The sum of the two rings on one side must never exceed 3600W on high range models, or 2800W on low range models.

If more power is needed, the generator will administer the power giving priority to the last command given.

### 3.2.- Troubleshooting

If the induction hob does not appear to be functioning correctly this does not always mean there is anything wrong with it. The following points should always be checked:

YOU NOTICE THAT...	POSSIBLE CAUSES	WHAT TO DO
The induction hob does not work. The keypad indicator lights are all off.	There is no electricity supply to the appliance. The power supply or connection is defective.	Check the state of the electrical installation. Check the fuses and the electrical circuit-breaker.
The installation circuit breaks when it is started up.	The hob connection is defective.	Check the connection conformity.
The induction hob stops working during use. It shows "C".	The electronic circuits have overheated.	Check the conformity of the installation, particularly the air inlets and outlets, as indicated in the instructions.
The induction hob stops working during use and emits a series of beeps.	A pan has boiled over onto the controls.	Press any button and the beeping will stop. Clean and continue cooking.
After the hob has started working, the keypad indicator lights continue to flash on and off.	The pan you are using is not suitable for induction cooking.	Use compatible kitchen utensils. You can check for compatibility with a magnet.
The fan continues ventilating for some minutes after the hob has been switched off.	The electronic circuits are cooling down.	This is perfectly normal.
The hob does not work. It shows a different message.	The electronic circuit is not working correctly.	Contact the after-sales technical service.

**Induction generator alarms:**

<b>ALARM</b>	<b>DEFECT</b>	<b>ACTION TO BE TAKEN</b>
F1	Ring NTC short-circuited	The NTC cable of the corresponding ring has been accidentally cut by the edge of the frame. Change the NTC to another ring.
F2	Ring NTC open	The NTC connector has come loose from the ring or the cable has been accidentally cut. Check the connection. If the problem persists, change the NTC.
F3	Power NTC short-circuited	The cable of the module radiator NTC has been accidentally cut by one of the frame edges. Change the power NTC by pressing down hard on the radiator and connecting to the circuit via the corresponding connector.
F4	Power NTC open	The power NTC connector has come loose or the cable has been cut. Check the connection. If the problem persists, change the NTC.
F5	Loss of communication	Error in communication between components.
F9	Overcurrent in generator	Normally the generator module recovers automatically from this situation. If this is not the case, the module is defective.
Setting and "c" flashing on 2 displays	Overheating of generator	Overheating is being produced in the generator radiator. The corresponding rings will be temporarily inactivated by start-stop cycles until the temperature is correct again. If this occurs with no apparent overheating, the appliance may be defective.
Setting (10) is flashing	No pan, or aluminium pan	The generator does not detect a pan on the corresponding ring, or the pan on the ring is made of aluminium.

**Control circuit alarms:**

<b>E1</b>	Eprom badly recorded or empty	Replace control circuit (Touch)
<b>NTC0</b>	NTC short-circuits	Replace control circuit (Touch)
<b>NTC5</b>	NTC incorrectly soldered	Replace control circuit (Touch)

Flow diagrams of induction generator alarms and control circuit alarms

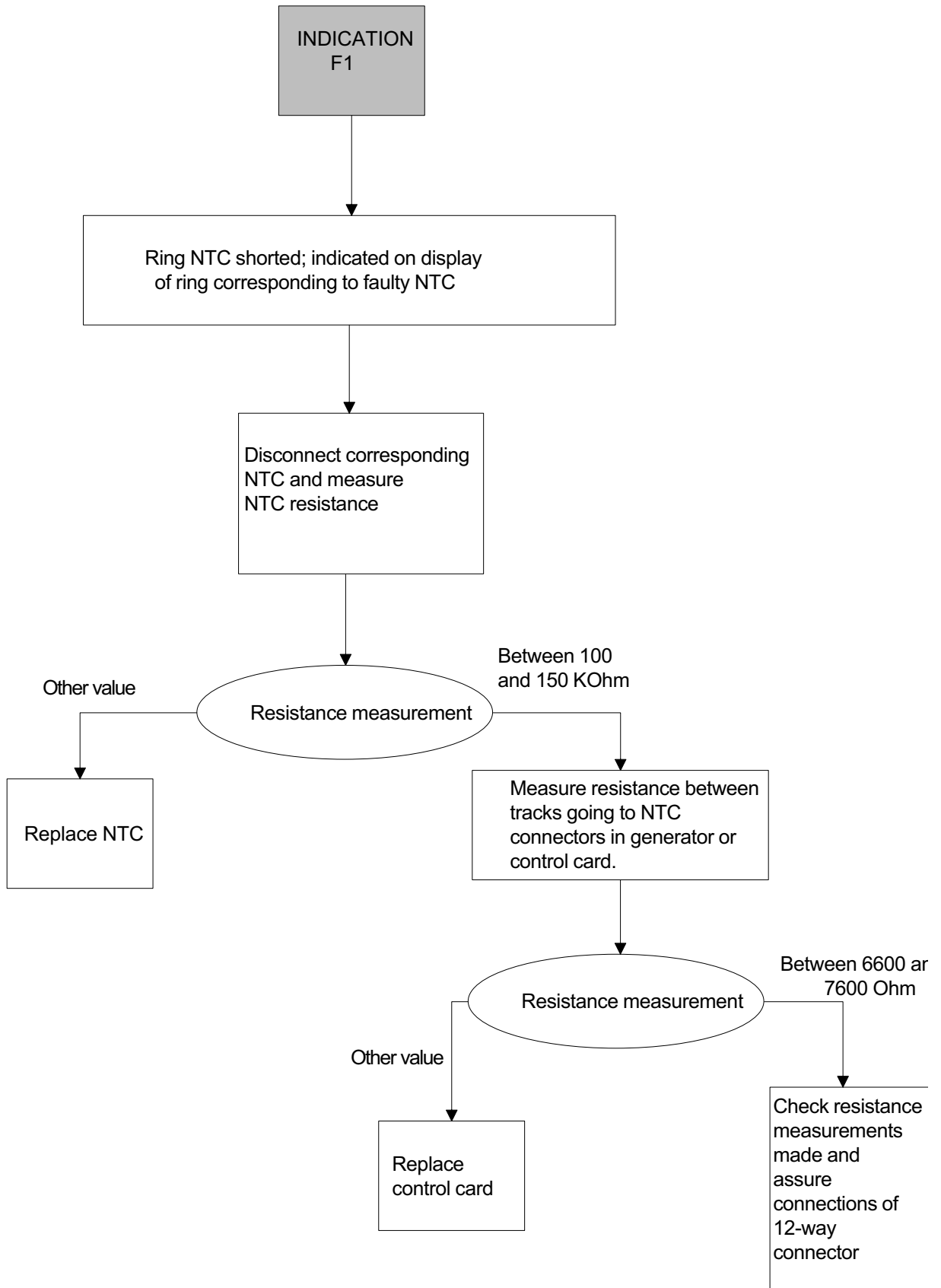

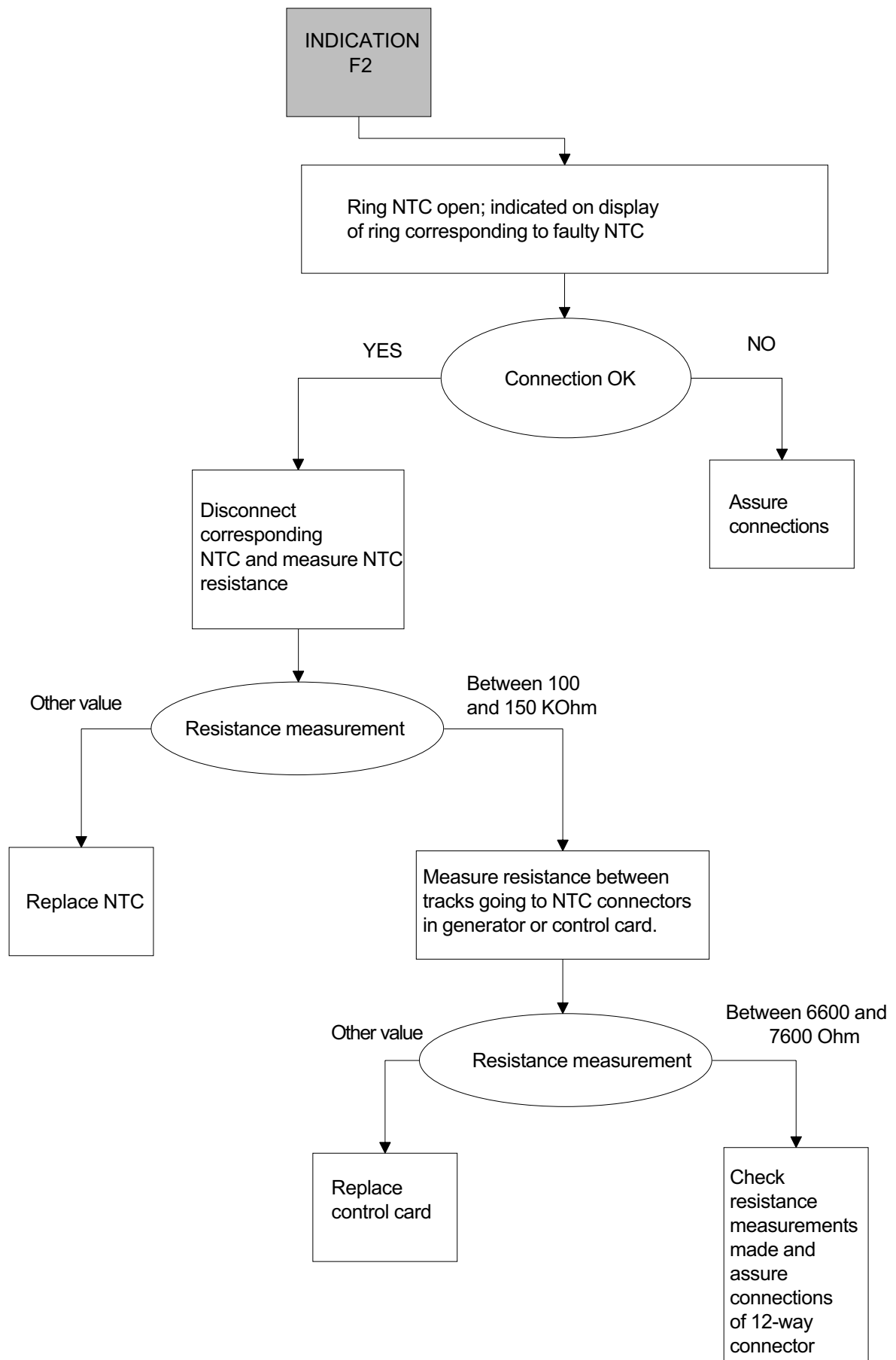

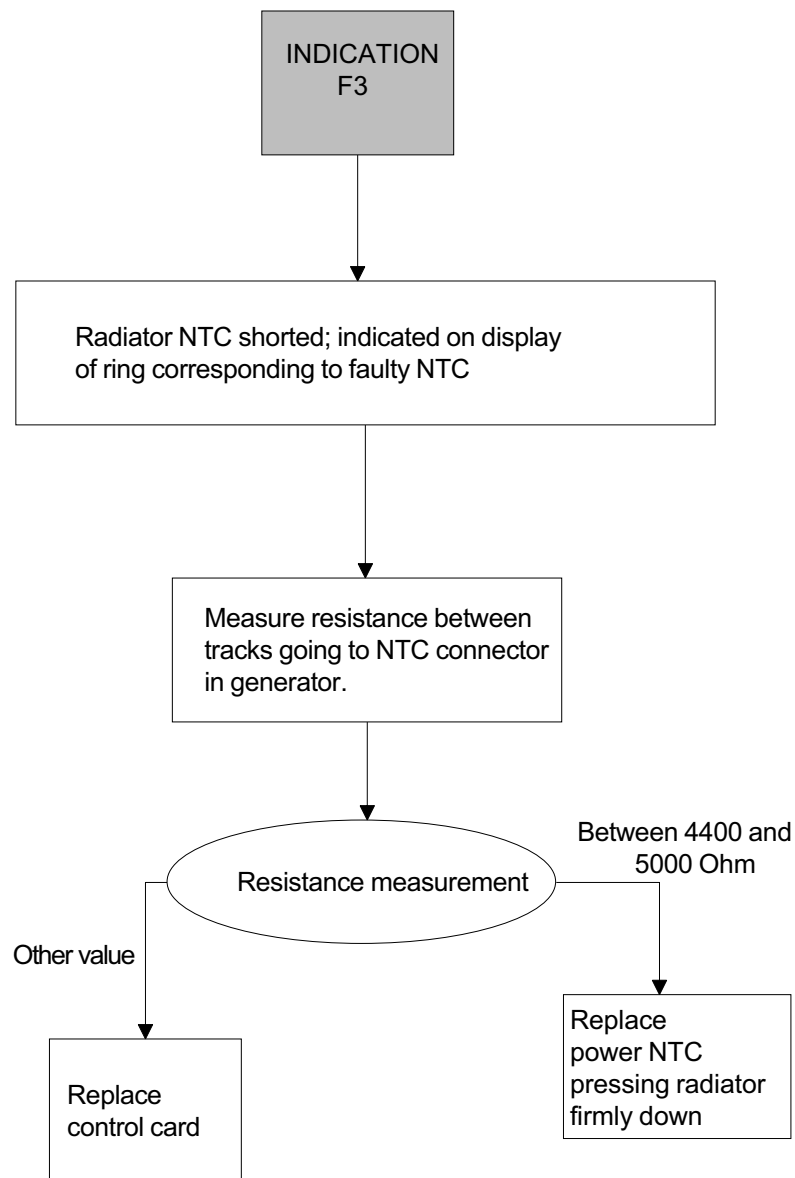

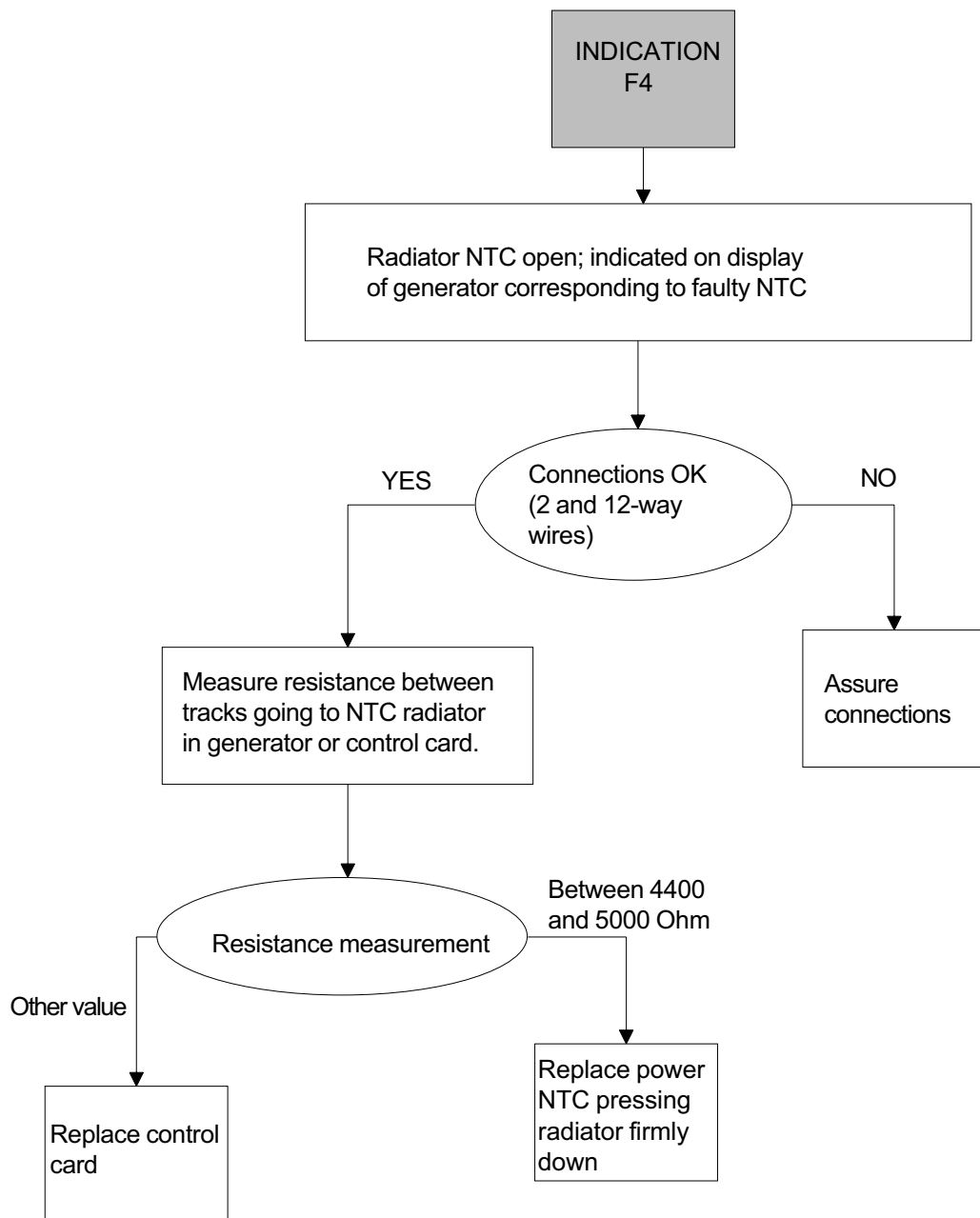

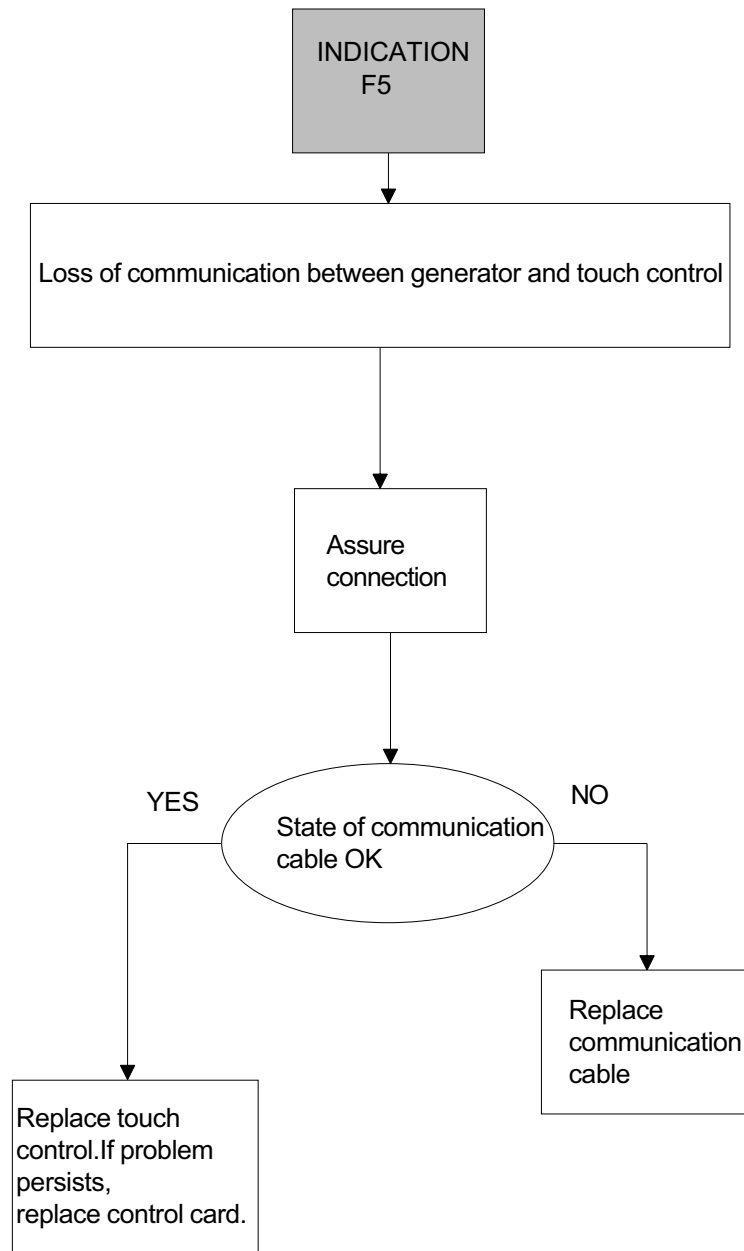

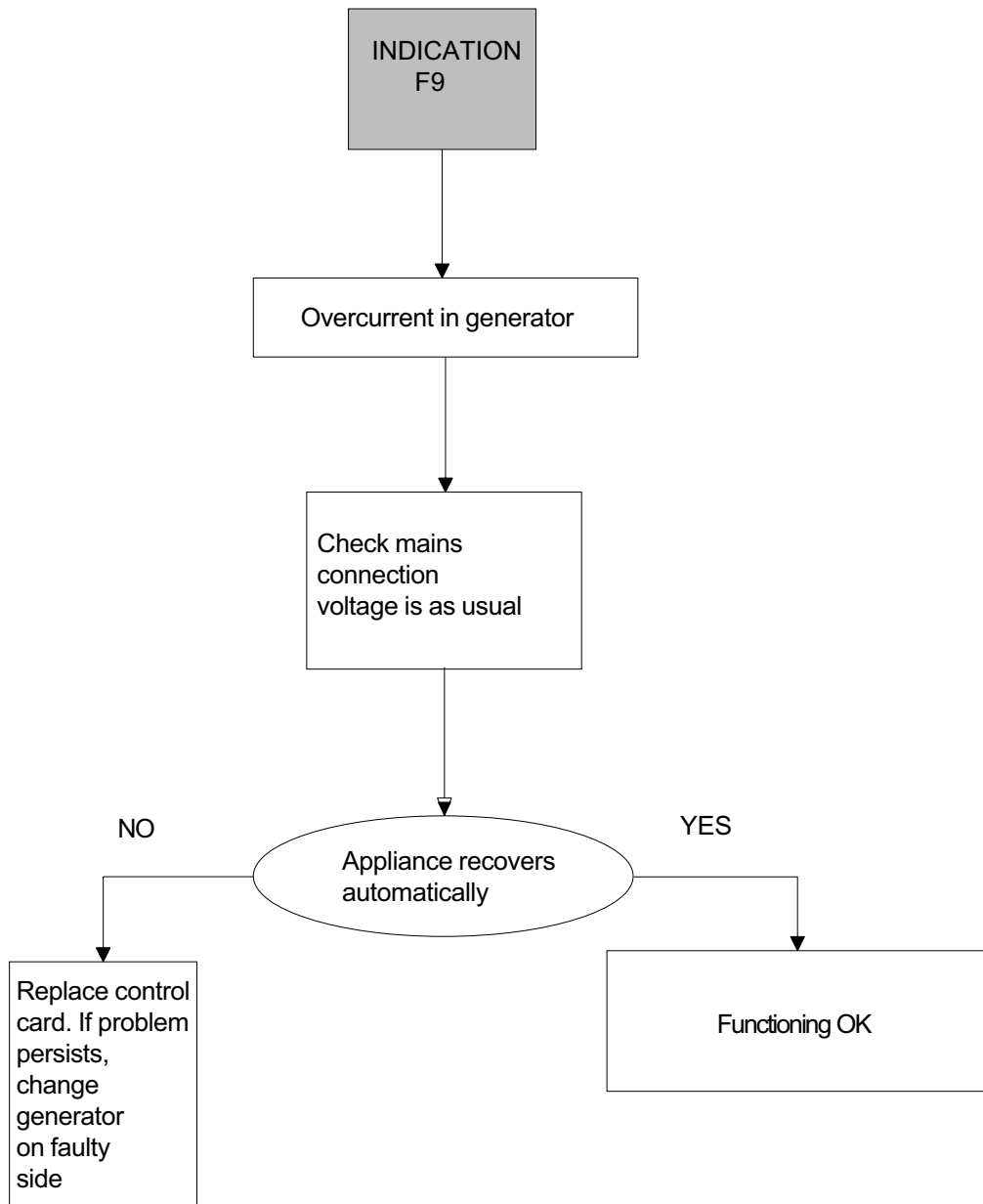

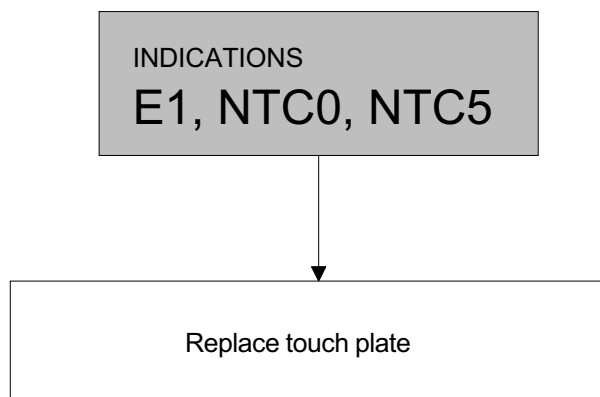
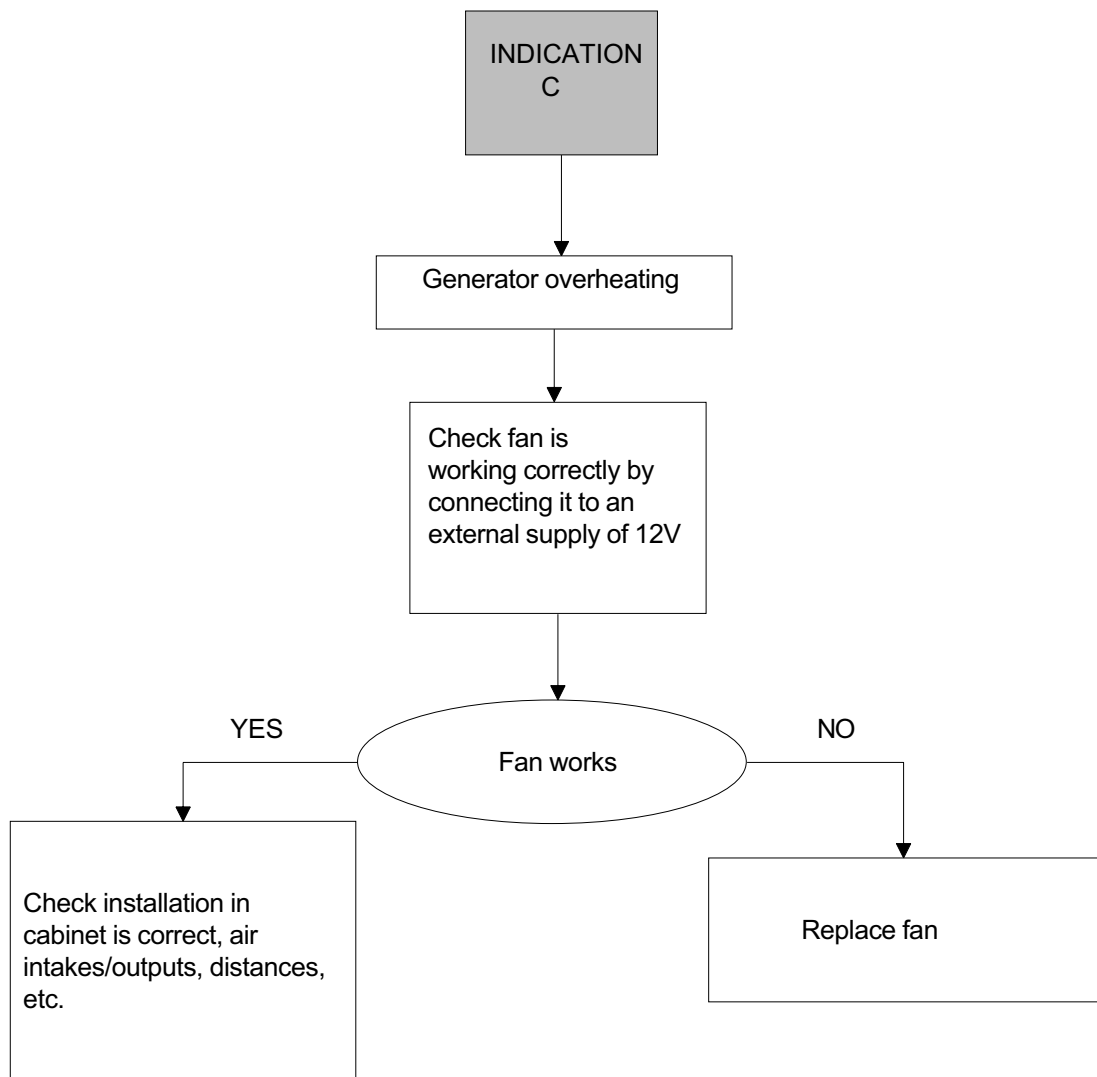

### 3.3.- Assembly and disassembly instructions

List of replaceable elements:

- Glass
- Supplied power module
- Non-supplied power module
- CD control card
- Touch control
- Fan
- Ring
- NTC

#### GLASS

With a large crosshead screwdriver, remove the screws from the sides of the hob and remove the vitro-ceramic part by pulling it upwards.

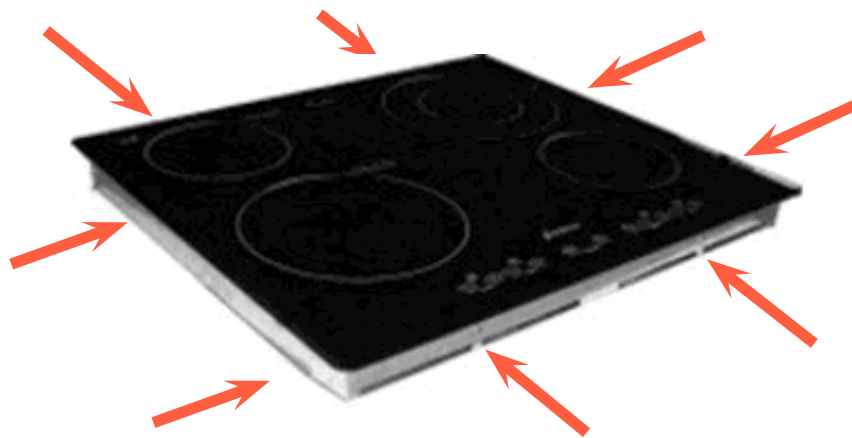

#### REMOVING THE GENERATOR UNIT

Lift up the generator unit slightly and turn it until it is in vertical position, resting on its rear part.

When it is in this position the two supply connectors leading to the lower part can easily be disconnected.

The generator unit can now be removed and placed on a flat surface where it will be easier to work with.

General view of generator unit from below.



## CONTROL CARD (CD)



1.- Remove control card connectors



2.- Remove control card from its fixings and from the connector



## SUPPLIED POWER MODULE

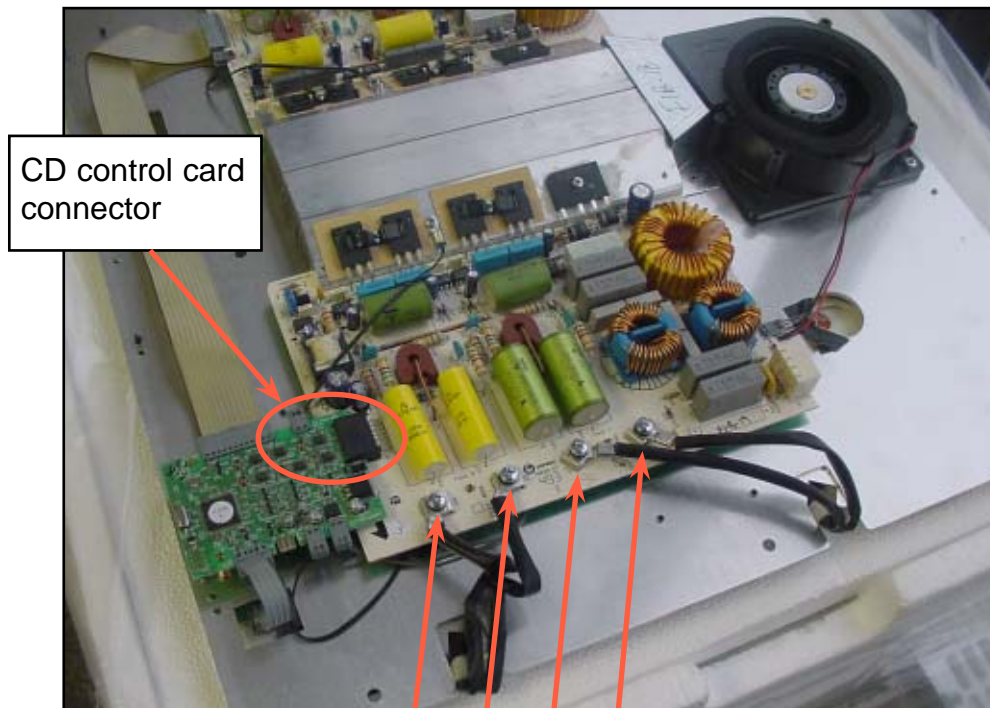

1.- The power cables must be removed from the rings.

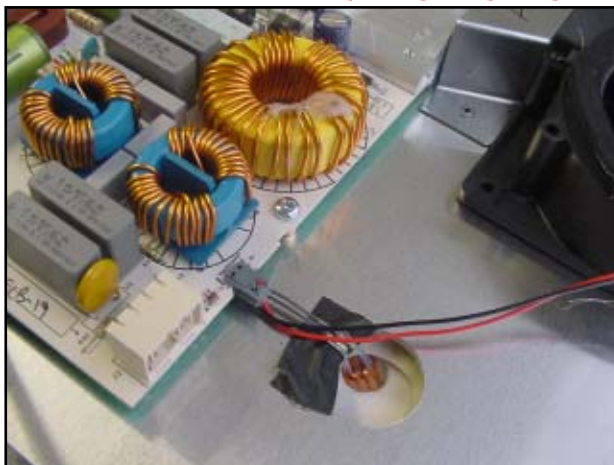

2.- Loosen one single screw.

3.- Remove the CD control card.



4.- Lift up the board and move it to the side.

## NON-SUPPLIED POWER MODULE

The process is the same as for the supplied power module, the only difference being that the control card does not need to be removed.

## TOUCH CONTROL

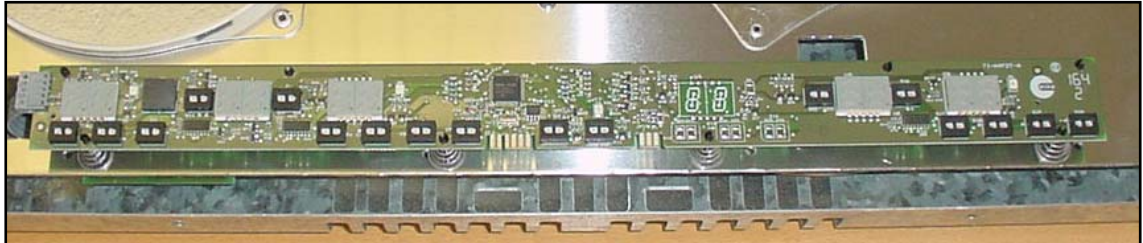

1.- Remove the touch control wiring.



2.- Pull the touch control up, bending the card as little as possible.

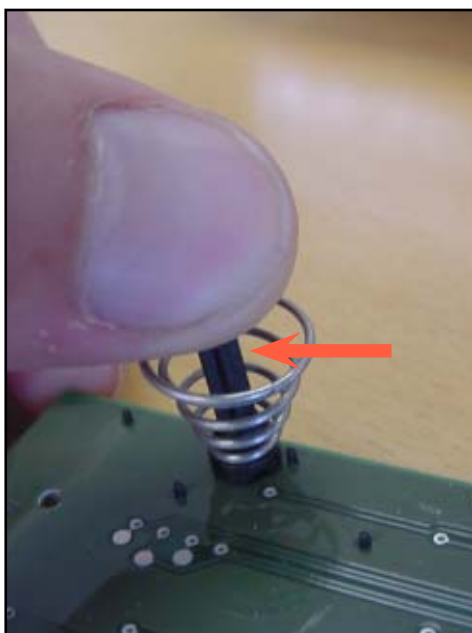

3.- If the spare touch control has no fixings, these can be easily removed by pushing the pivot gently to one side.

## RING NTCs

Changing the NTCs is done with a similar process for all the rings. Only the location of the connector on the generators is different.

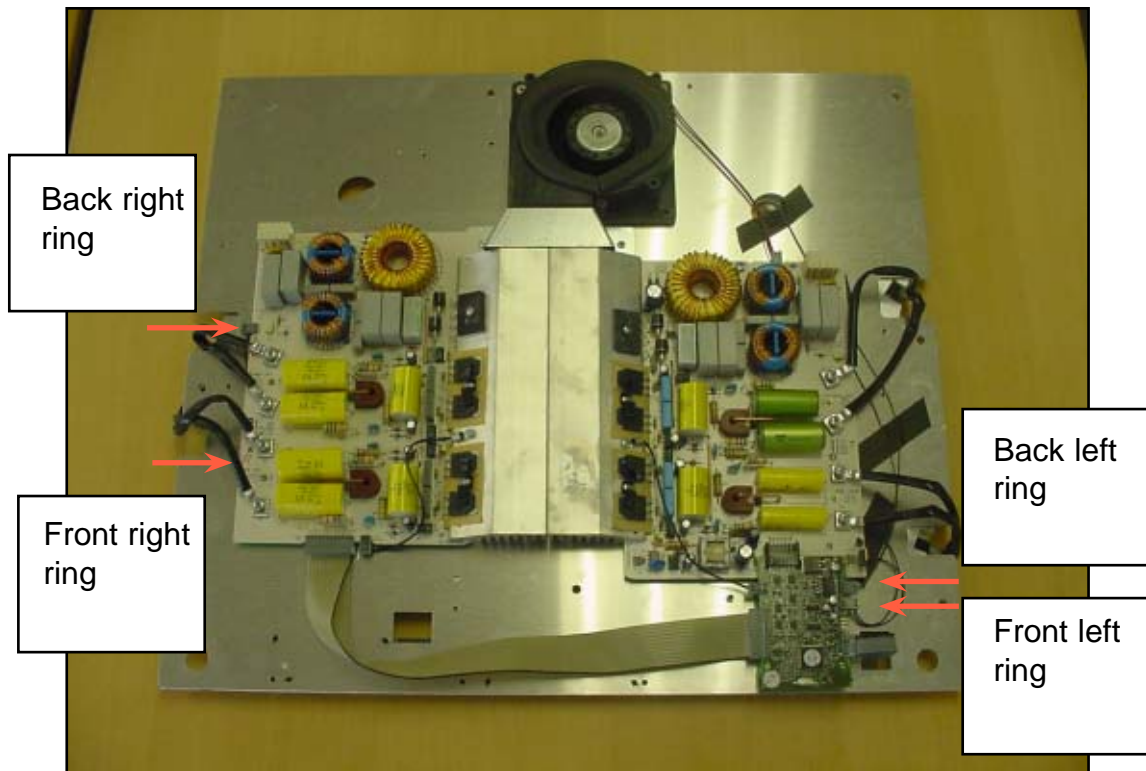

- 1.- Remove the faulty NTC connector.
- 2.- Turn the generator unit around.



3.- Lift up the mica insulation. (It is stuck down with a drop of glue to prevent it from moving during transport).



4.- Pull the NTC upwards to release it.

## RADIATOR NTC

The two radiator NTCs are removed in the same way, although one is connected to a power module and the other to the control card.

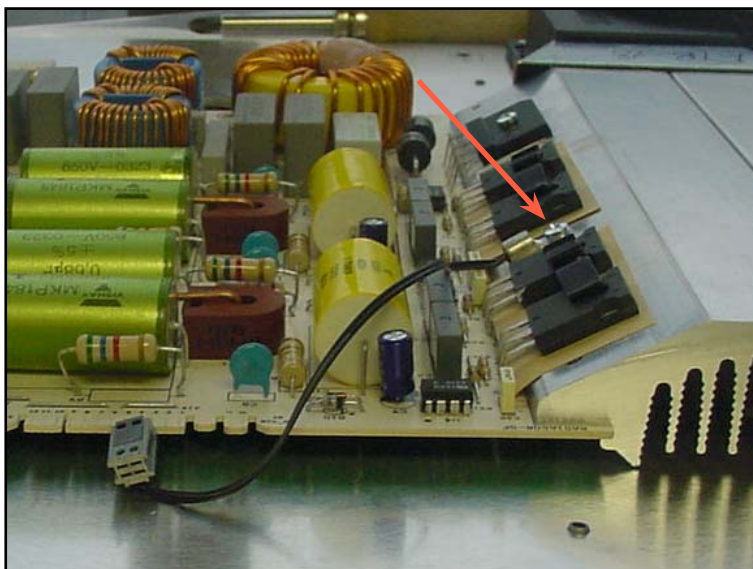

1.- Remove the radiator NTC connector.

2.- Remove the NTC using a screwdriver.

## FAN

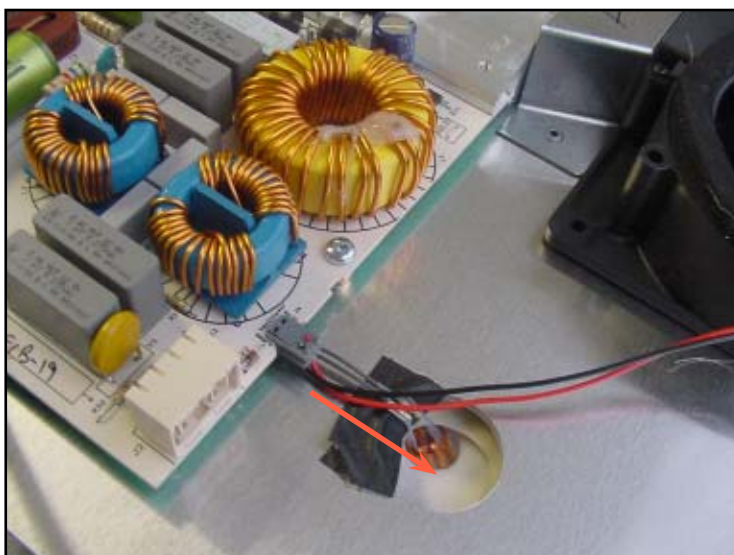

1.- Remove the supply to the fan.

2.- Remove the two screws holding the fan in place.



© **FAGOR ELECTRODOMESTICOS, S.COOP.** 2004  
Bº San Andrés, s/n  
20500 Mondragón (Gipuzkoa)  
España (Spain)