

SMC01-09

System

User's Manual

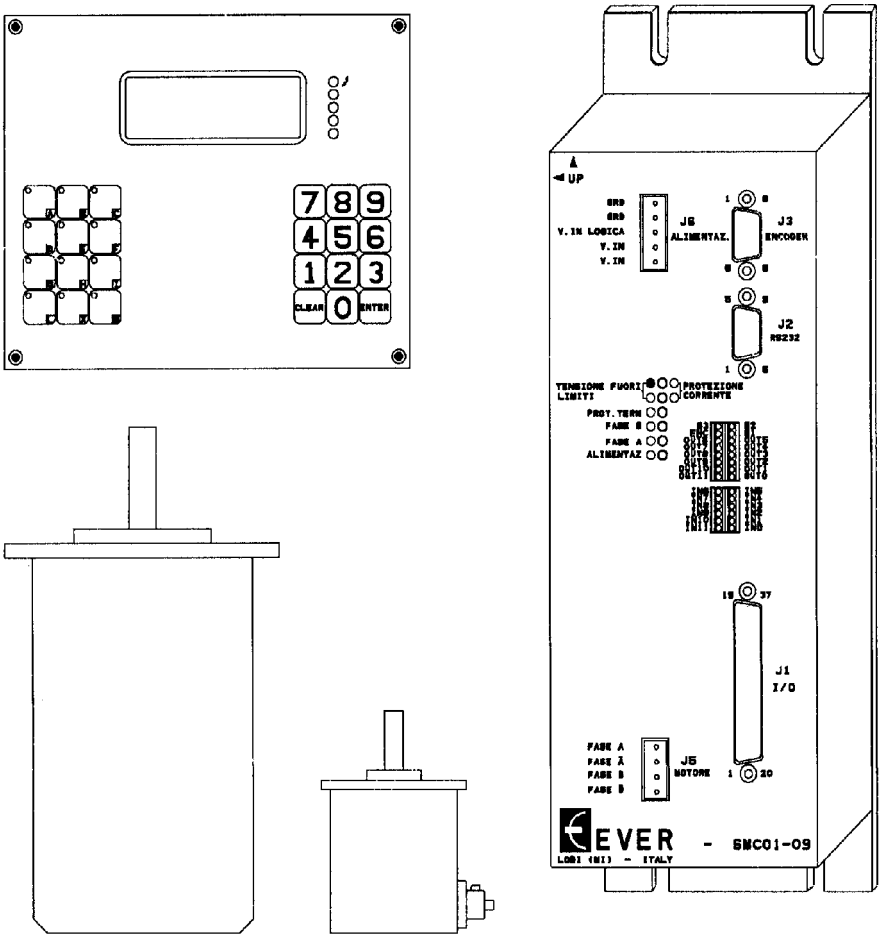

GENERAL INDEX :

PRELIMINARY	:	P. 3
INTRODUCTION	:	P. 5
CHAPT. 1	:	Presentation of the SMC01-09 system and technical specifications .	P. 7
CHAPT. 2	:	Block diagrams	P. 15
CHAPT. 3	:	Options and Accessories	P. 23
CHAPT. 4	:	Software	P. 43
CHAPT. 5	:	Support information (installation and diagnosis of malfunctions)	P. 51
CHAPT. 6	:	Conditions of warranty validity	P. 65

PRELIMINARY

Our company is renowned for the excellent quality of its products, and the competence of its experts, able to solve any operational problem.

We offer ranges of tested products with numerous accessories, as well as advanced, complete solutions for the functions of FEED, ENSLAVEMENT, POSITIONING.

The information given in this manual has been carefully checked so that it is absolutely reliable.

We reserve the right to modify the product in the interests of improved performance.

EVER accepts no liability for damage caused by lack of expertise or improper use of the equipment.

This manual provides general descriptions, instructions for installation, operative procedures, technical and functional descriptions to make our system easy to understand and use.

The appendix to the manual gives further technical details, to be used when authorized by EVER.

In case there is the need for specific information for a more personalized use of the system, our experts will always be at your disposal, to ensure a friendly and fruitful collaboration.

INTRODUCTION

The STEPPER motor, from the family of DC MOTORS, deserves special consideration.

On one hand it has the same characteristics of strength typical of brushless motors, without mechanical components subject to wear, and on the other enables control of position and speed at a lower cost than the brushless motor, as closure of the rotor reaction ring in operation is not necessary.

For these reasons the Stepper motor is becoming increasingly important, at a time when automation devices with increasingly sophisticated performance and competitive cost imposed by international competition are produced.

For these reasons, the technology of Stepper motors is in the implementation phase on linear motors also, which will enable the creation in the near future of movement systems featuring a price/performance ratio that today would be unthinkable.

The reasons that until now have restricted the use of the Stepper motor to the advantage of the brush motor, despite the limits of the latter are:

- a) the low level of available power
- b) too low resolution of the step angle
- The current tendency among manufacturers of Stepper motors is to increase power.

Today there are already motors with power of about 4 HP with fan systems that enable even very heavy work cycles.

- The resolution of the step angle is the parameter that affects:

- 1) static and dynamic precision of movement
- 2) rotation speed
- 3) continuity of torque
- 4) the option of position ring closure with incremental encoder.

These motors were classified in the low precision range of motion activators because of the low resolution of step angle that can be obtained with traditional, low intelligence activation systems.

From the above, we can understand how important it is to have access to logical and power electronic devices like the SMC01-MPP09 activation system that enable reduction of step angle (up to 1/128) and the manufacturing of position and/or speed control apparatus with the most advanced characteristics and highly competitive cost with Stepper motors.

*** CHAPTER 1 ***

PRESENTATION OF THE SYSTEM SMC01-09 AND
TECHNICAL SPECIFICATIONS

INDEX :

PARAGRAPH 1.1 :	General information	p. 8
PARAGRAPH 1.2 :	Technical specifications	p. 12

1.1 GENERAL INFORMATION

The SMC01-09 system is an intelligent operating system for Stepper motors with innovative technological and operative characteristics.

Besides the previously mentioned operating system, it features a PLC able to handle the various functions of the machine, equipped with 12 inputs and 12 outputs plus one for service.

It can easily be understood how a system with these requisites, combined with compact size, simplifies the design and layout of machines with which it is used, compared to traditional systems in which the control logic is physically separated from the operative part.

Among the main characteristics of the PLC section, there is the possibility of connection to a Personal Computer via serial interface RS232, enabling an exchange of information and commands aimed at rendering the system programmable and expandible, thanks to Software XPRES elaborated by our experts.

EVER offers two types of local control and programming terminals - optional - consisting of keyboards TSMC01 and TVME01.

There are 12 function keys and one numerical key on keyboard TSMC01.

Display of data is ensured by a 4-line LCD display with 20 characters/line.

The keyboard has a double serial interface RS232 so that more than one SMC01-09 system can be monitored and interfacing with any RS232 system is possible.

The TVME01 keyboard is the new version of the TSMC01 and features a matrix of 64 keys that can be configured according to requirements, a larger LCD display with 256 x 64 points (display size 149.6 x 43 mm).

It also has a USER connector which can be connected with 8 external keys and a potentiometer for regulation of display contrast.

As regards the OPERATION section, the basic feature is Microstepping operation which is an efficacious solution to the problems of resonance typical of traditional systems.

Fig. 1 shows the response to the transient of the rotor of a Stepper when the phases are commanded at full step.

In this case the phase currents of the motor are square wave, while in the micro-step systems the wave of the phase currents has almost sinusoidal characteristics (Phase A) and cosinusoidal characteristics (Phase B).

This difference can be seen in the drawing of Figure 2.

The frequency of the sinusoidal current determines the angular speed of the rotor.

The typical sinusoidal wave shape ensures a gentle rotor movement, without swinging.

The sophisticated technology used for the project enables our operating system to obtain fractionary step angles up to 1/128 of a step, or 25600 positions per revolution.

The microstep therefore enables accurate positioning, as well as solving resonance problems.

For high-speed movement, and if a more accurate position control is needed, the SMC01-09 system enables (optional) the ring to be closed with a bidirectional incremental encoder with zero signal controlled directly by the system.

In figure 3 we can see the operation of SMC01-09 from the front, with connectors, signal leds, silk-screen printings and maximum measurements all shown.

The complete system is contained in a compact cabinet, on the front of which are the following connectors:

- Inputs /Outputs (J1)
- RS 232 (J2)
- Encoder (J3)
- Motor (J5)
- Supply (J6)

There are also 3 sets of leds that display:

- Input state
- Output state
- Passage of Encoder to Zero
- 2 service leds for CPU state
- Power ON
- Phase A and Phase B excitation
- Thermal protection
- Over current protections
- Overvoltage
- Undervoltage

The cabinet is fixed to a base that carries the 4 wires for system fixing and functions as heat dissipator.

For the SMC01-09 system a software operative system has been created to solve all problems of Operation, Enslavement and Interpolation.

EVER's software department can at any time provide you with personalized software to suit any requirements.

FIG. 1 : RESPONSE OF THE ROTOR TO THE TRANSIENT

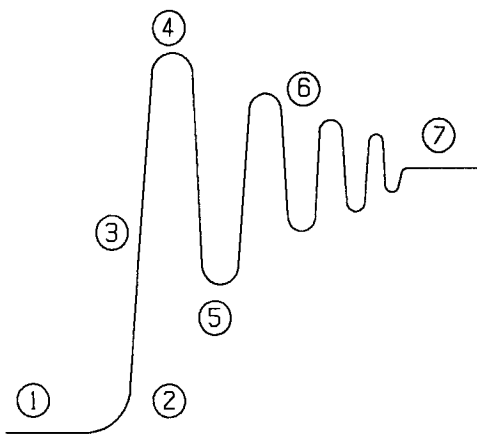

- 1 : INITIAL POSITION OF ROTOR
- 2 : THE PHASES ARE EXCITED TO ENABLE THE ROTOR TO COMPLETE A FULL STEP
- 3 : THE ROTOR ACCELERATES AT MAX. SPEED TOWARDS THE NEXT POSITION
- 4 : THE ROTOR PASSES THE DESIRED POSITION DUE TO ITS INERTIA AND THAT OF THE LOAD
- 5 : THE MOTOR TORQUE FORCES THE ROTOR TO RETURN TO THE RIGHT POSITION WHICH IS AGAIN PASSED BUT WITH A LESSER MARGIN OF ERROR BECAUSE OF LOSS DUE TO FRICTION
- 6 : THE CYCLES ARE REPEATED BUT GROW INCREASINGLY SMALL
- 7 : THE ROTOR IS POSITIONED IN THE RIGHT SPOT

FIG. 2 : DIFFERENCE BETWEEN PHASE CURRENT MANAGEMENT BY THE FULL STEP AND MICROSTEP SYSTEMS

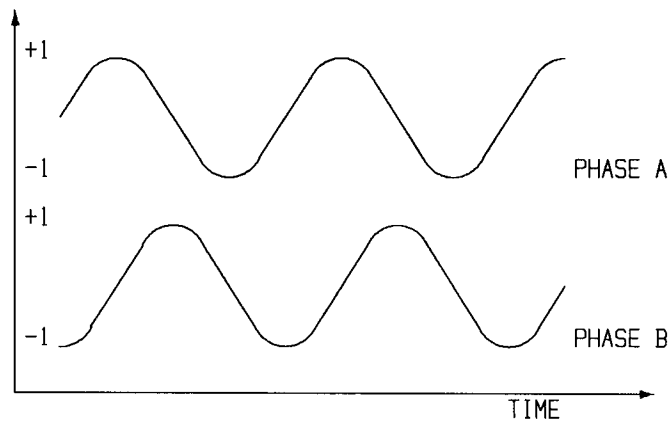
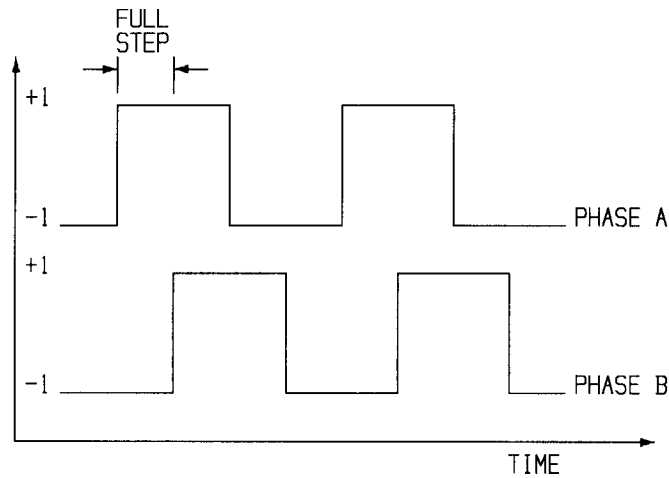
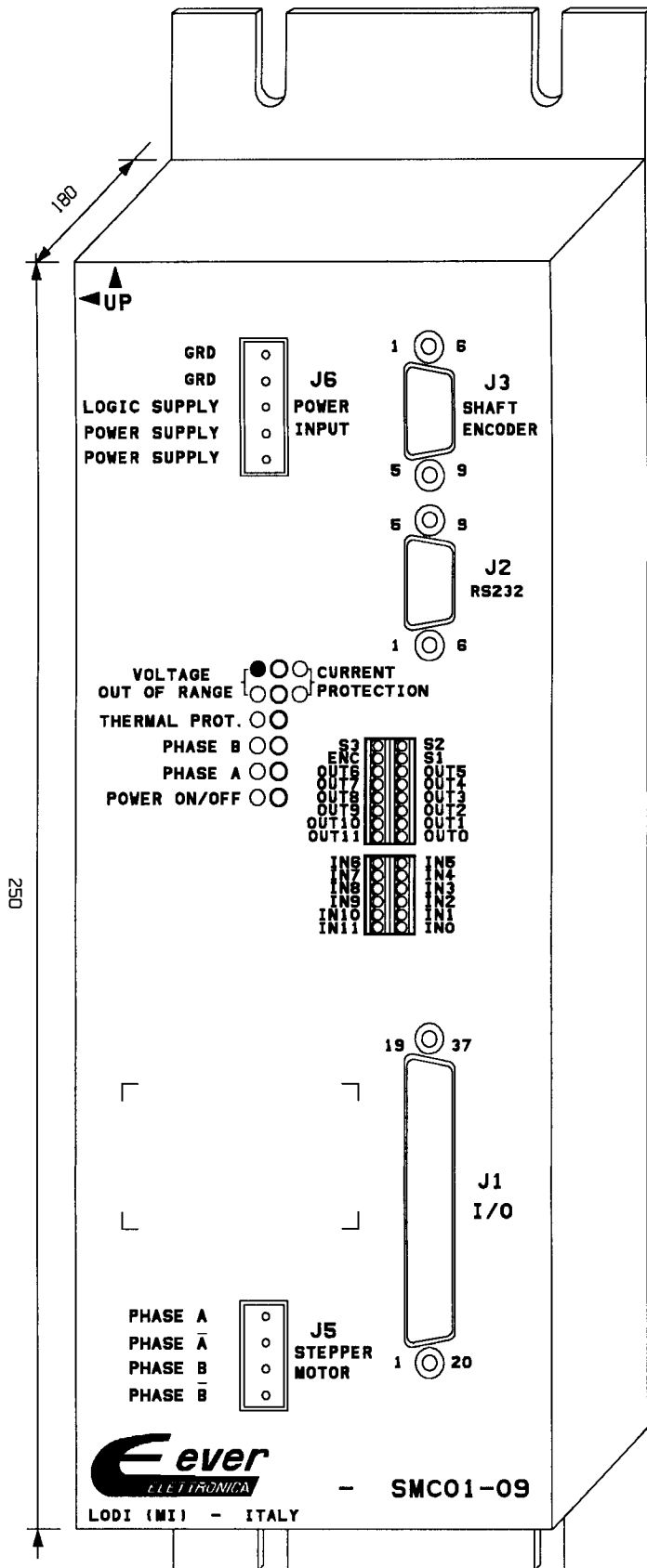

FIG.3 : FRONT VIEW SMC01-09



1.2 TECHNICAL SPECIFICATIONS

SUPPLY: the same value except on clamps
with separate logic and power
from 75 Vcc to 180 Vcc

LOGIC ABSORPTION: about 100 mA

POWER ABSORPTION ...: depending on the motor and the
load applied to it.
The average currents absorbed by
the system with motor at maximum
speed without load on the shaft,
and 120 V Vin are as follows:
at 2.3 A/phase --> 550 mA
at 5.6 A/phase --> 1020 mA
at 7.5 A/phase --> 1650 mA
at 10 A/phase --> 2200 mA
at 12 A/phase --> 2400 mA

MAX. PHASE CURRENT ..: 15 A

CHOPPER FREQUENCY ...: 20 Khz (ultrasonic)

STEPS PER REVOLUTION : from 200 (full step) to 25600
(1/128)

OPERATING TEMPERATURE: from -10 C to + 50 C

HUMIDITY: 90% without condensation

INCORPORATED PLC ...: sequential type, 12 inputs of
which 4 fast with Vin from 15 to
28 Vcc. 12 static outputs + 1
service output (200 mA each) of
24 Vcc.
16 timers, time base 10 msec.
16 16-bit counters.

INTERFACE ENCODER ...:(optional) for incremental,
bidirectional encoder with Zero,
for fast ring closure and
position.
For NPN, PNP, PUSH-PULL encoders.

INPUTS /OUTPUTS: optoisolated and protected
against short-circuits.

PROTECTIONS: overvoltage, undervoltage, short-circuit towards earth , phase/phase and phase/earth types, thermal and motor brake.

SERIAL INTERFACE: RS232 or current loop

LED DISPLAY: inputs, outputs, supply, Zero encoder, protective devices and service.

MAX DISSIPATOR TEMP. : +80 C

MAX DISSIPATED POWER : $PD (W) = 8.54 \times I_{\text{phase}} (A) + V_{\text{in}}(V) \times I_{\text{phase}}(A) \times 0.0015$

CONNECTIONS: extractable terminal box for feed and motor; inputs/outputs, RS232, encoder with tank connector series D 7,5 A 1000 V insulation.

REGULATIONS: max. and min.speed, acceleration and deceleration , steps per revolution , phase current and standby.

BOX DIMENSIONS: 250 x 180 x 100 (mm)

DIMENSIONS OF BASE ..: 307.3 x 100 x 5 (mm)

WEIGHT: 2.23 Kg

NOTE :

*** CHAPTER 2 ***

BLOCK DIAGRAMS

INDEX :

PARAGRAPH 2.1 : General drawing
and block diagram p. 18

FIG. 4 : OVERVIEW OF SYSTEM SMC01-09
OUT OF BOX

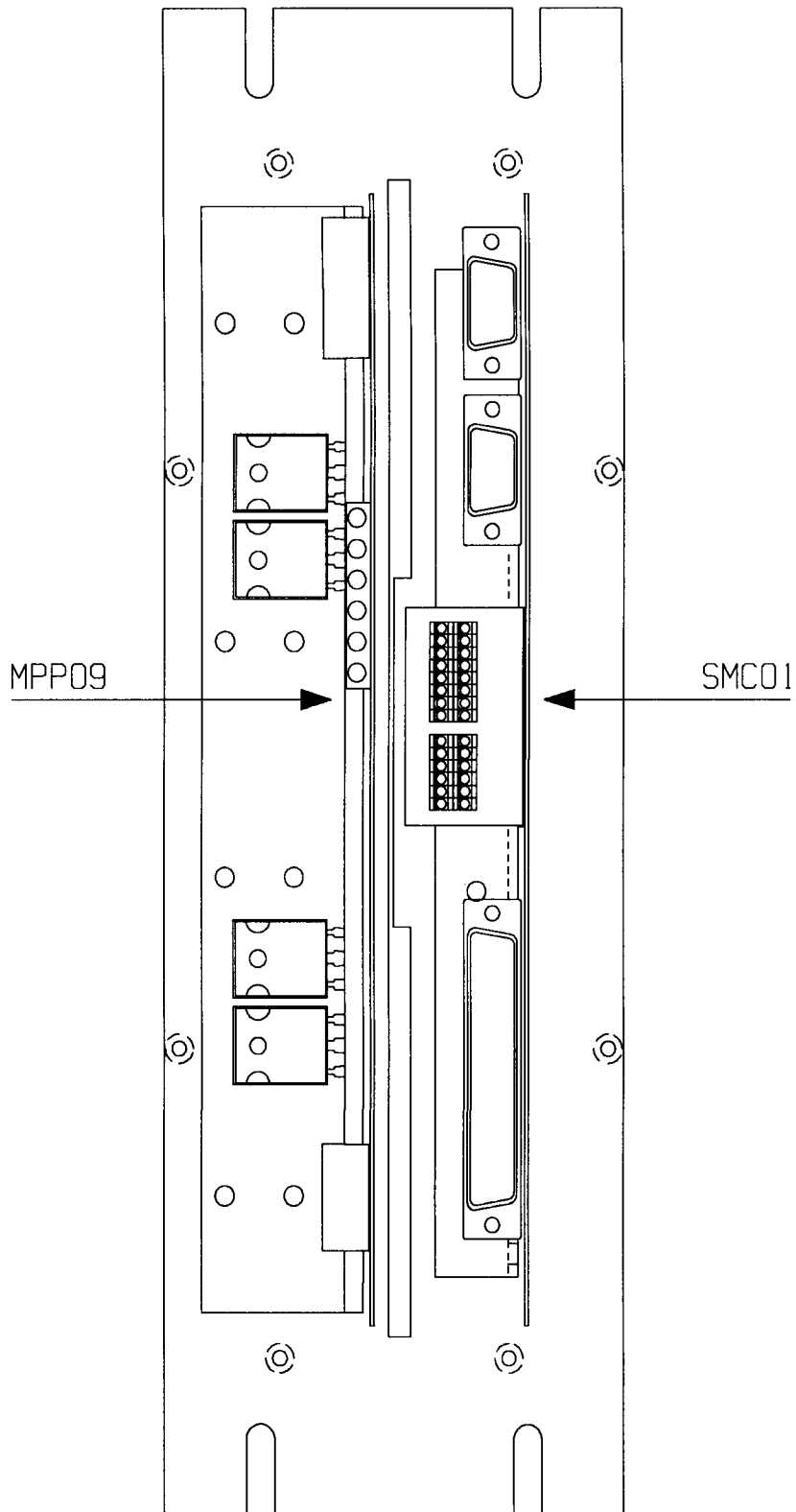
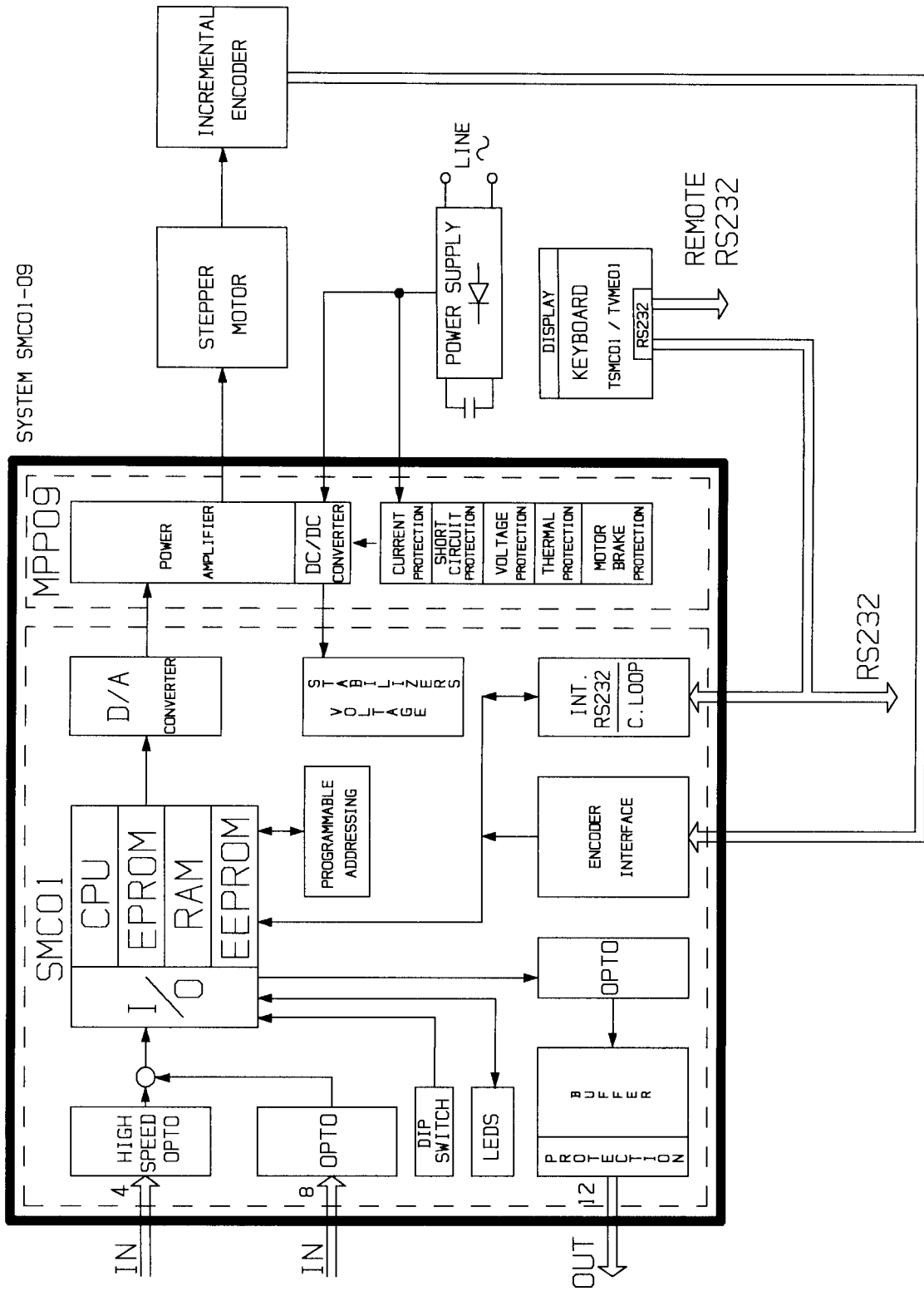

FIG. 5 : BLOCK DIAGRAM SMC01-09 SYSTEM



2.1 GENERAL DRAWING AND BLOCK DIAGRAMS SYSTEM SMC01-09

In the drawing in figure 4 the position of cards SMC01 and MPP09 inside the box is shown.

An initial idea of the functionality of the system is evident from the block diagram in fig. 5.

As well as the functional block denominated SYSTEM SMC01-09, there are two functional blocks named STEPPER MOTOR and POWER SUPPLY that are essential to the system's functioning.

The blocks TSMC01/TVME01 and INCREMENTAL ENCODER constitute optional subsidies for local programming and closure of the position ring that will be discussed in chapter 3 OPTIONS AND ACCESSORIES.

In fig. 6 and fig. 7 the block diagrams of the cards SMC01 and MPP09 are shown.

From these diagrams we can see the separation between logic and power within the system and the clarity of its design.

FIG. 6 : SMC01 BLOCK DIAGRAM

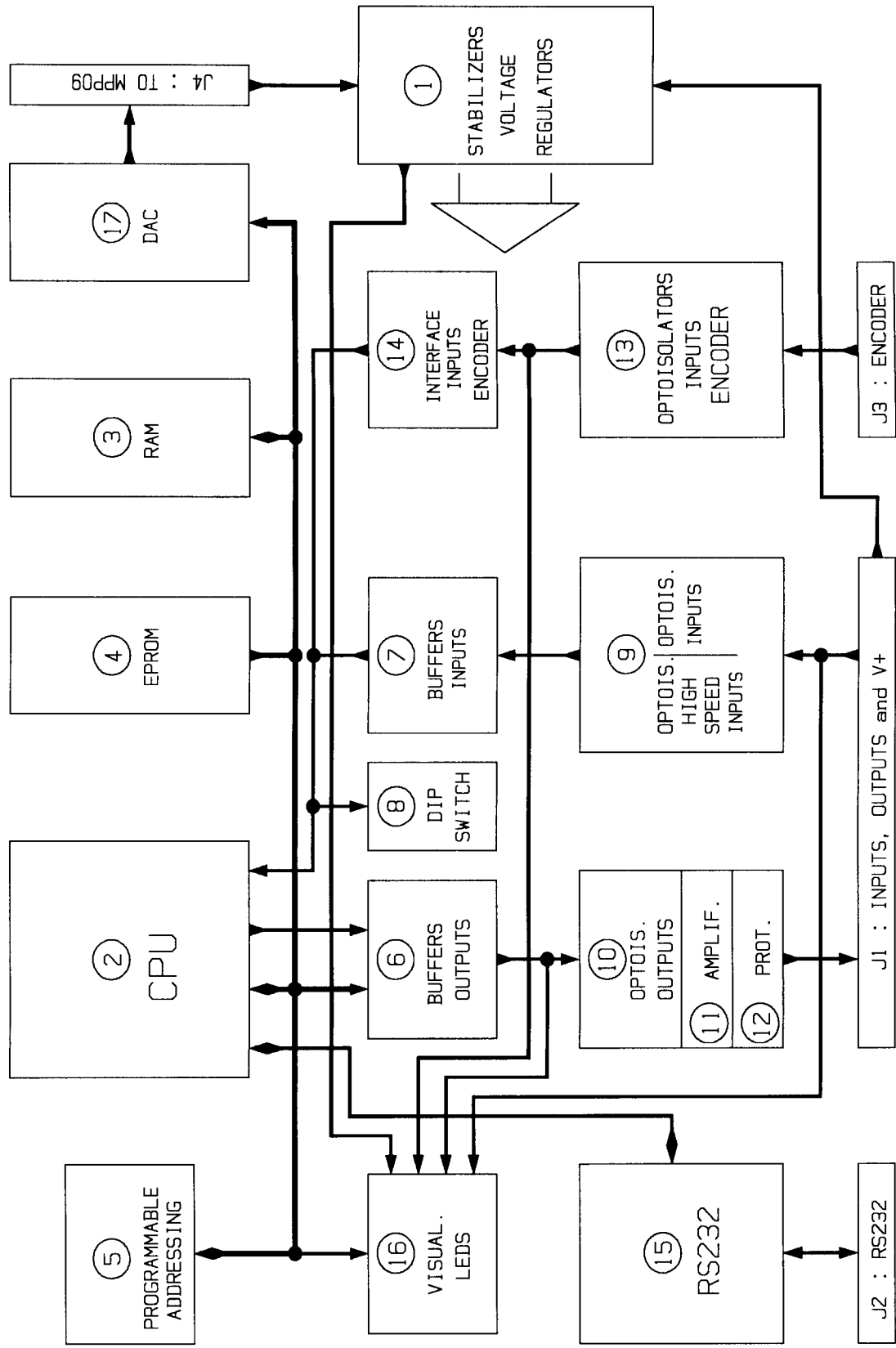
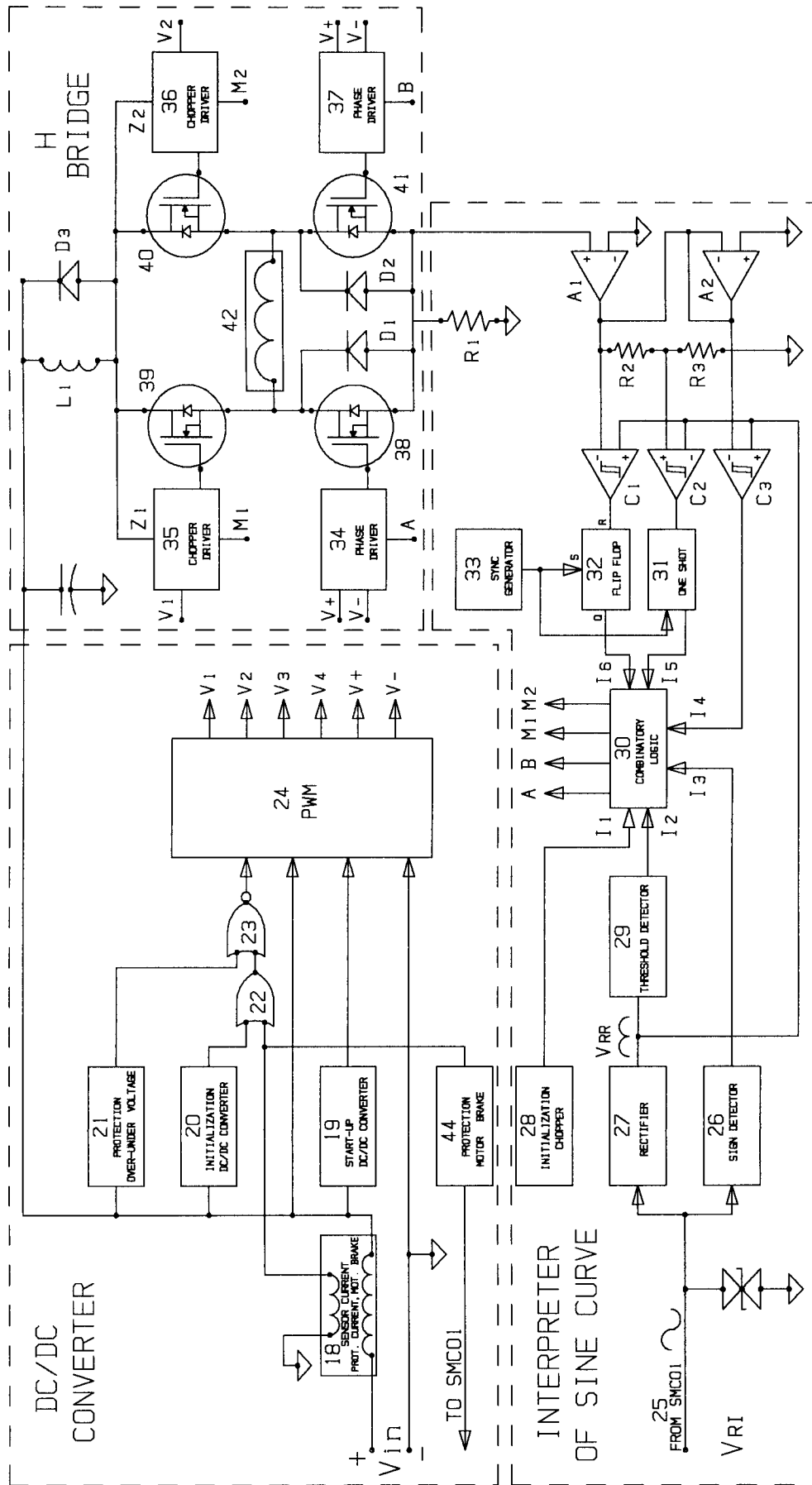

FIG. 7 : BLOCK DIAGRAM POWER CARD MPP09



NOTE :

*** CHAPTER 3 ***

OPTIONS AND ACCESSORIES

INDEX :

PARAGRAPH 3.1 :	PRESENTATION	p. 24
PARAGRAPH 3.2 :	IEN-POS	p. 24
PARAGRAPH 3.3 :	TSMC01	p. 24
PARAGRAPH 3.4 :	TVME01	p. 25
PARAGRAPH 3.5 :	ALSMC09	p. 26
PARAGRAPH 3.6 :	CK-SMC01	p. 26
PARAGRAPH 3.7 :	SUPPLEMENTARY DISSIPATOR KIT	p. 26
PARAGRAPH 3.8 :	WIRE RS232 SMC01 <--> PC	p. 27

3.1 PRESENTATION

The SMC01-09 system was designed to offer the user the benefits of a high level of versatility and so EVER created a series of options and accessories for use in all types of application.

With the SMC01-09 system we are therefore able to offer you options IEN-POS , TSMC01 and TVME01 as well as accessories ALSMC09, CK-SMC01, a SUPPLEMENTARY DISSIPATOR KIT and a RS232 wire for direct connection to a Personal Computer.

This chapter gives the user all information necessary to immediate use of the options and accessories; besides the functional descriptions, the illustrated tables at the end of the chapter give all information on mechanical measurements and foot measurements of the connectors.

The chapter OPTIONS AND ACCESSORIES was put before the chapter INSTALLATION, USE AND LIMITS (chap. 5) as a prior overview of the complete system, to facilitate immediate use.

In figure 11 we can see the SMC01-09 system complete with all options and accessories.

3.2 IEN-POS

For applications demanding maximum precision, positioning and fast movement, ring closure by means of an incremental encoder is necessary.

Thanks to the IEN-POS option the SMC01-09 system is capable of direct control of a bidirectional incremental encoder with Zero signal, simply by connecting the encoder cable to the special connector on the front of the system.

The IEN-POS is an electronic card that is fitted inside the cabinet , without changing the dimensions and measurements of the system.

The IEN-POS option accepts bidirectional incremental encoders with Zero signal of the NPN, PNP and PUSH-PULL type.

The internal bidirectional counter is a 24-bit (direct calculation up to 16.777.200), is updated by the encoder steps and communicates directly with the CPU.

3.3 TSMC01

The TSMC01 keyboards is a local unit of programming and display of machine parameters.

There is a numerical keyboard and a 12-key function keyboard for programming.

The data are displayed on a screen with liquid crystals (LCD) with 4 lines and 20 characters per line.

The keyboard has a double serial interface RS232 so that it can control more than one SMC01-09 system and dialogue with a remote terminal also (PC).

To connect to the SMC01-09 system, connect the wire supplied with the keyboard to the RS232 connector on the front of the system.

On request We supply a cabinet consisting of a front part and cover in which the TSMC01 keyboard can be enclosed and protected from dust and other foreign bodies.

N.B.: the metallic parts of the LCD display must not come into contact with the metal front panel or with any other object that is not insulating.

In the drawings of figs. 12, 13 and 14 we can find all the mechanical measurements of the TSMC01 keyboard, its cabinet and the connector pin-out.

3.4 TVME01

The TMVE01 keyboard is the new version of the TSMC01.

Its fundamental characteristics are:

- a) 64-key matrix with leds that can be configured as required
- b) large LCD display with 256x64 points (display size 149.6 x 43 mm.)
- c) USER connector to which 8 external keys can be connected (for example a key switch or control keys that must be placed far from the keyboard) and an external potentiometer for regulating display contrast.

Functionally it is identical to the TSMC01 but has only one interface RS232.

It is connected to the SMC01-09 system in the same way as the TSMC01.

On request we supply a cabinet made up of a front panel personalized on the basis of the keys used, and a back cover.

N.B.: none of the metallic parts of the LCD display must touch the metallic front panel or any other object that is not insulating.

The mechanical drawings shown in figs.15, 16, 17 and 18 give all measurements for the keyboard, cabinet and pin-out of USER and RS232 connectors.

The drawing in figure 16 shows an example of front panel for personalized key configuration.

3.5 ALSMC09

This is a double linear power supply that enables two alternating voltages to be rectified and supplies the insulated supplies needed by INPUTS, OUTPUTS and ENCODER states of card SMC01.

Considering that these supplies of power must have a range of between 15 and 28 Vcc (24 Vcc recommended), the alternate voltages to the power supply inputs must be between 11 and 20 Vac (18 Vac recommended to obtain the nominal output of 24 Vcc).

There is a protection fuse for each output.

In figure 19 the mechanical dimensions and footage of the connectors of feeder ALSMC09 are shown.

3.6 CK-SMC01

This is a simple square-wave generator used to send a clock from outside to an input of the logic card SMC01.

It uses the same supply as the SMC01 inputs.

It is able to generate a variable frequency through an external potentiometer with a Fmax/Fmin ratio of about 20.

Its simplicity makes it a useful accessory when major excursions of clock frequency and a high level of frequency stability are not required.

Figure 20 shows the mechanical dimensions and pin-out of the connector.

3.7 SUPPLEMENTARY DISSIPATOR KIT

The SMC01-09 system has been mechanically designed to be fixed to a thermal dissipant surface.

If this is not available, for example if the wall of the electricity cabinet (where the system is lodged) is too thin or small, another system must be found for disposal of the heat produced by the power card MPP09.

EVER's catalogue includes a SUPPLEMENTARY DISSIPATOR KIT specially created to solve this type of problem.

The kit consists of a winged dissipator to be fixed to the bottom of the system, by two anchoring clamps, a fan and the necessary screws for assembly.

In Figures 21, 22,23 and 24 we can see the mechanical measurements fo the parts of the kit, how it is assembled and the resulting dimensions of the SMC01-09 system complete with auxiliary dissipator.

As can be seen in figures 23 and 24, the fan produces a flow of air concentrated on the winged dissipator so as to allow considerable air circulation and excellent heat dissipation.

The kit was studied to be fitted also on machines already equipped with a SMC01-09 system, as the points at which the kit is fastened to the machine are the same as those on the SMC01-09 system without the kit.

The frontal dimensions also remain the same, and only depth increases by 96 mm.

3.8 WIRE RS232 SMC01-09 <--> PERSONAL COMPUTER

This is a standard RS232 wire modified to make it compatible with the pin-out of connector RS232 of card SMC01.

The possibilities offered by this interconnection will be described in chapter 4 DESCRIPTION OF SOFTWARE.

Figure 25 shows the electric schematics of the two versions of wires for 25 pins RS232 connector or 9 pins RS232 connector.

All the possible connections between more SMC01-09 and one PC or between more SMC01-09 and one Keyboard TSMC01 and the wires for this connections are mentioned on the "XPRES MANUAL".

FIG. 11 : OPTIONS AND ACCESSORIES OF THE SMC01-09

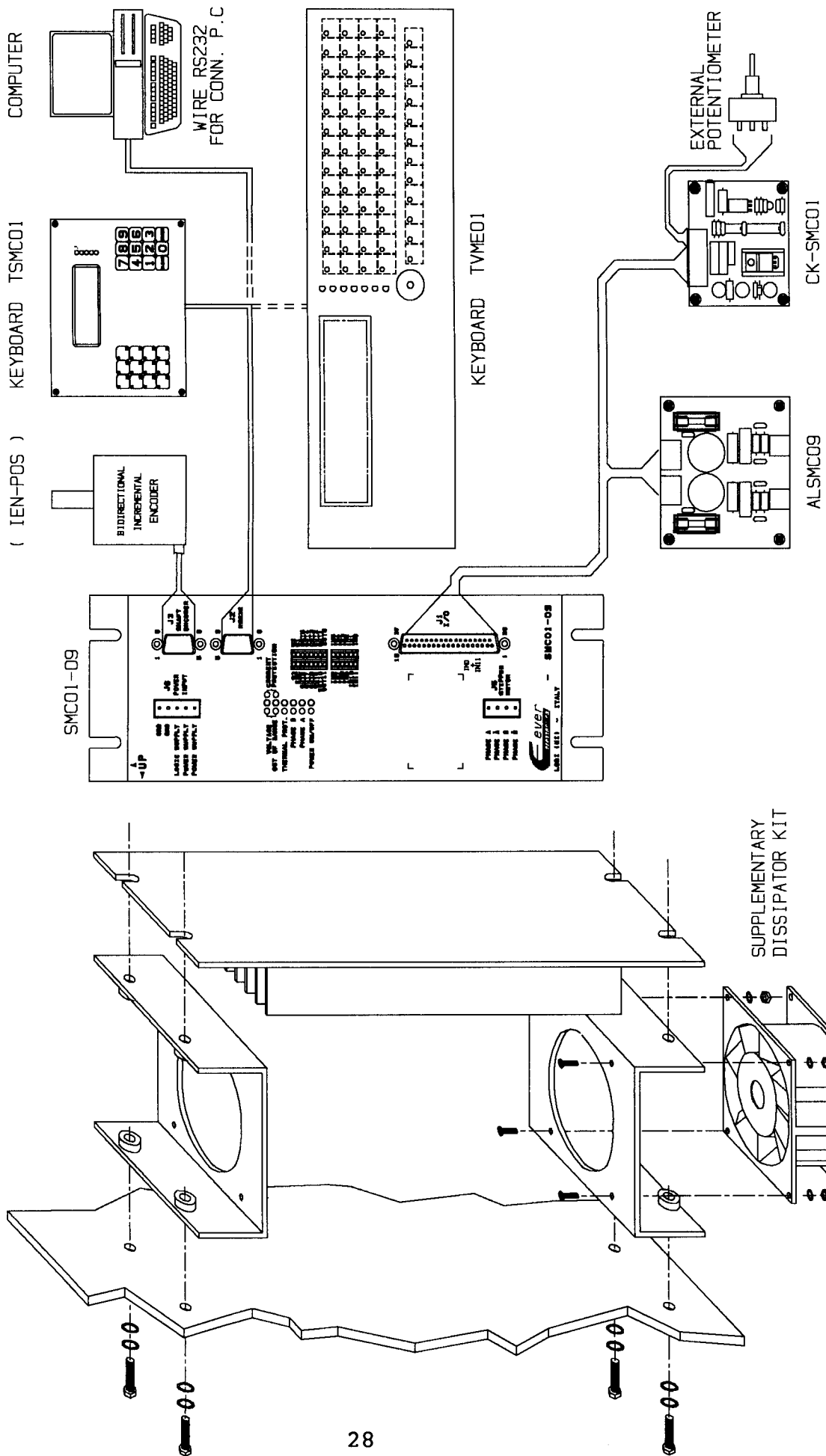

FIG. 13 : MECHANICAL DESIGN FRONT PANEL TSMC01 KEYBOARD

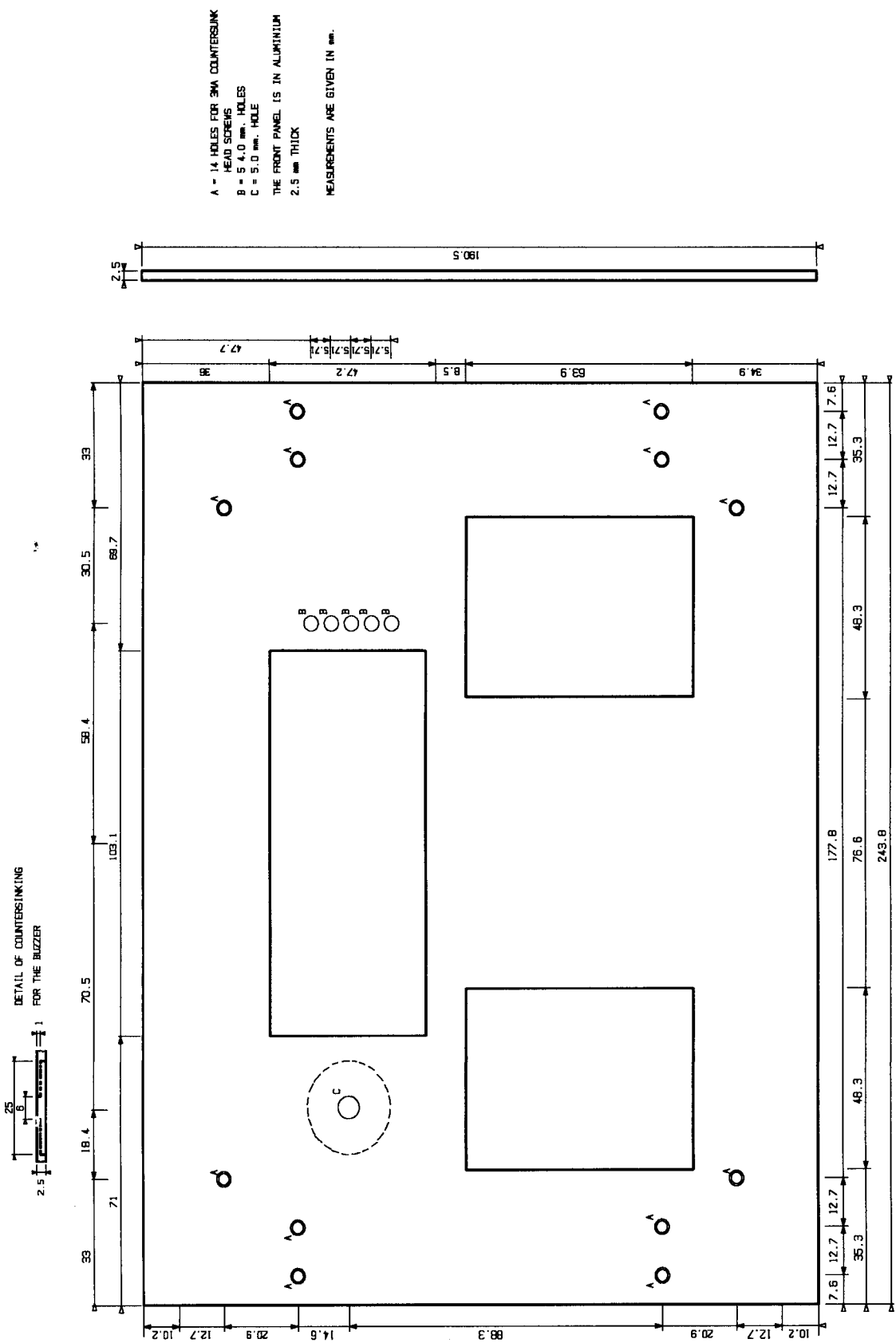
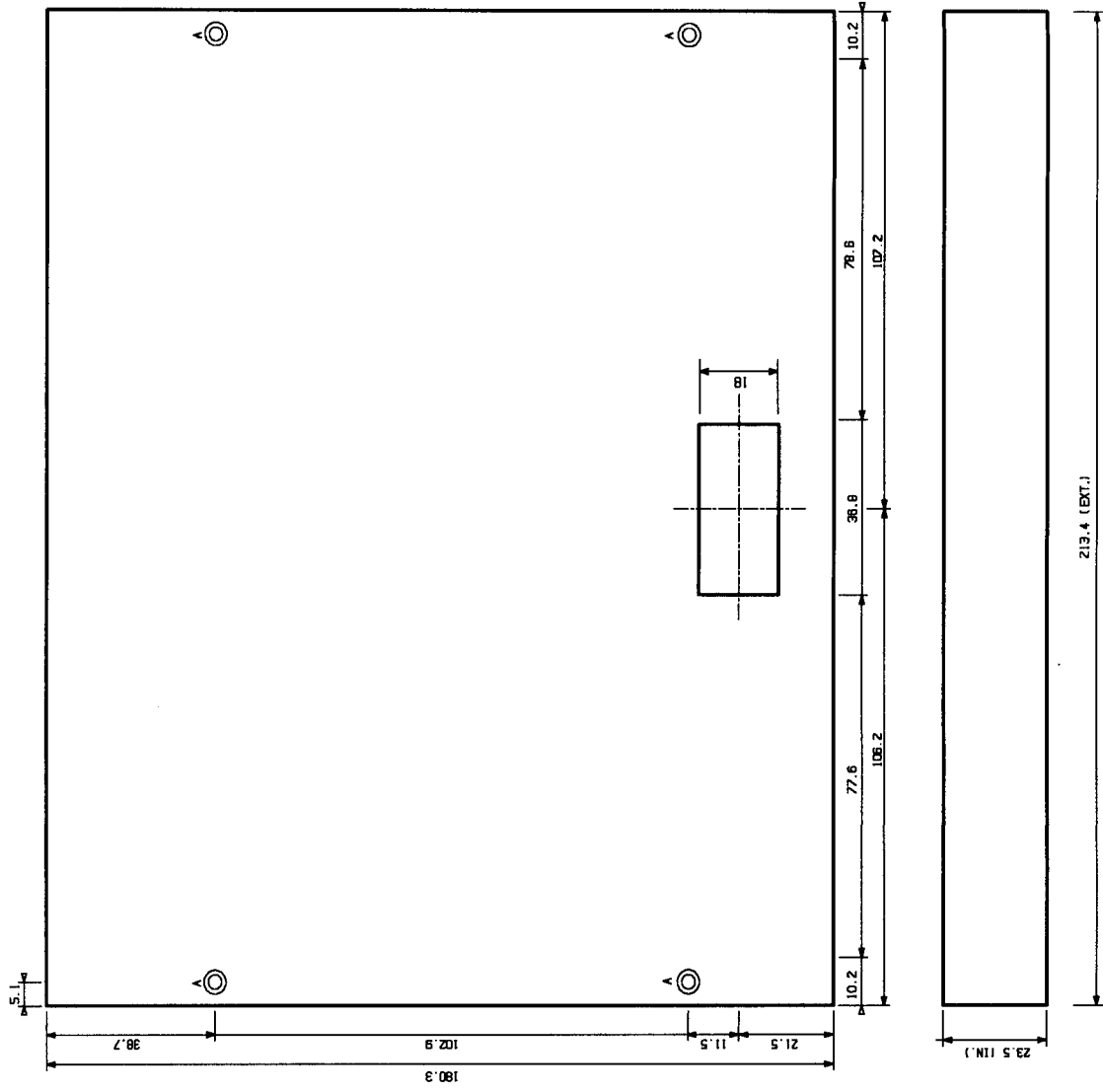
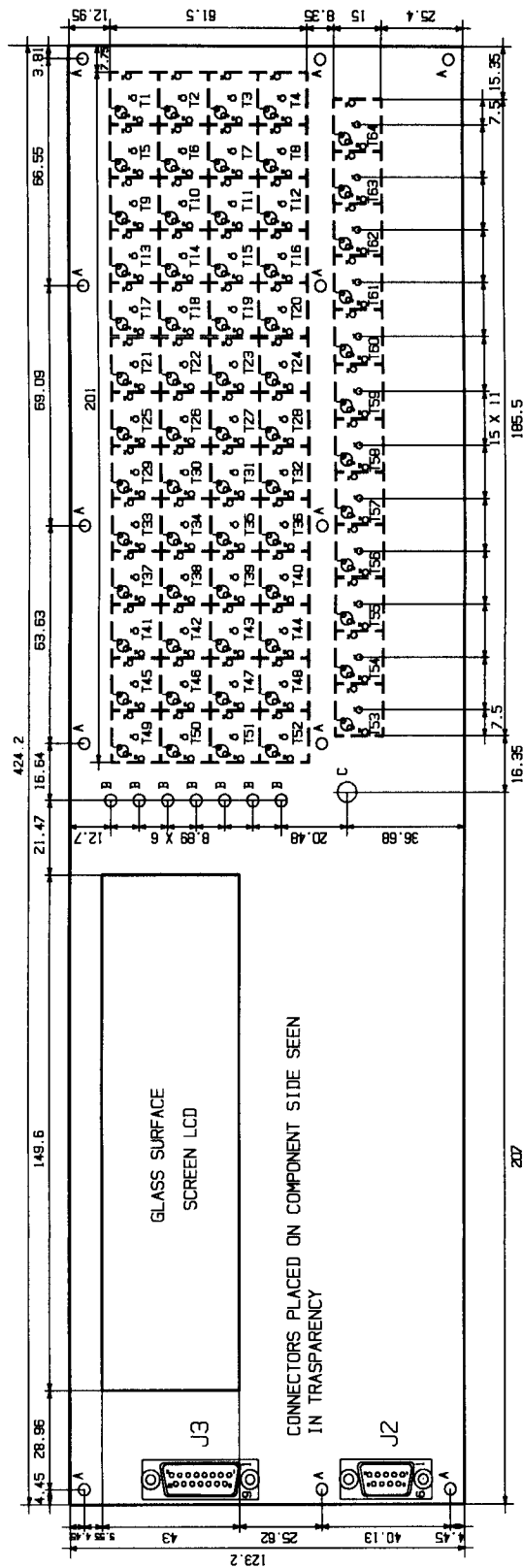

FIG. 14 : MECHANICAL DESIGN BACK COVER TSMC01 KEYBOARD



A = 4 HOLES FOR 3MA TYPE SCREWS
 THE BOX IS MADE OF ALUMINIUM 1.5 mm. THICK
 THE MEASUREMENTS ARE GIVEN IN mm

FIG. 15 :
MECHANICAL DESIGN OF DIMENSIONS OF PCB CARD TM2E01 KEYBOARD AS TEMPLATE FOR POLYCARBONATE PANEL
(STANDARD VERSION) AND PIN OUT OF RS232 CONNECTORS (J2) AND USER (J3)



HOLES A : HOLES FOR FIXING THE PCB TO THE FRONT PANEL 3.5 mm
HOLES B : HOLES ON FRONT PANEL CORRESPONDING WITH LEADS - 3.5 mm
HOLE C : HOLE ON FRONT PANEL CORRESPONDING WITH THE BUZZER - 8 mm
MEASUREMENTS ARE GIVEN IN mm

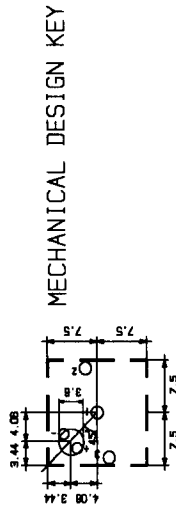

- J2 : CONN RS232
DELTA 9 M PINS CONNECTOR
- J3 : CONN. USER
DELTA 15 M PINS CONNECTOR
- J2.1 =
J2.2 = Rx/D
J2.3 = Tx/D
J2.4 = DHR
J2.5 = GND
J2.6 =
J2.7 = -12 v
J2.8 = +12 v
J2.9 = +5 v
- J3.1 = T1 EXT
J3.2 = T2 EXT
J3.3 = T3 EXT
J3.4 = T4 EXT
J3.5 = T5 EXT
J3.6 = T6 EXT
J3.7 = T7 EXT
J3.8 = T8 EXT
J3.9 = COMMON
J3.10 =
J3.11 =
J3.12 =
J3.13 = -9 v
J3.14 = CONTRAST
J3.15 = +5 v
- EXTERNAL KEY
TO CLOSE ON PIN 9 'COMMON'
- CONNECT TO THE EXTERNAL
POTENTIOMETER

N.B. : NONE OF THE METALLIC PARTS OF
THE LCD DISPLAY MUST COME INTO CONTACT
WITH THE METALLIC FRONT PANEL OR ANY
UNINSULATED OBJECT

FIG.16 : MECHANICAL DESIGN OF A TYPED PERSONALIZED FRONT PANEL

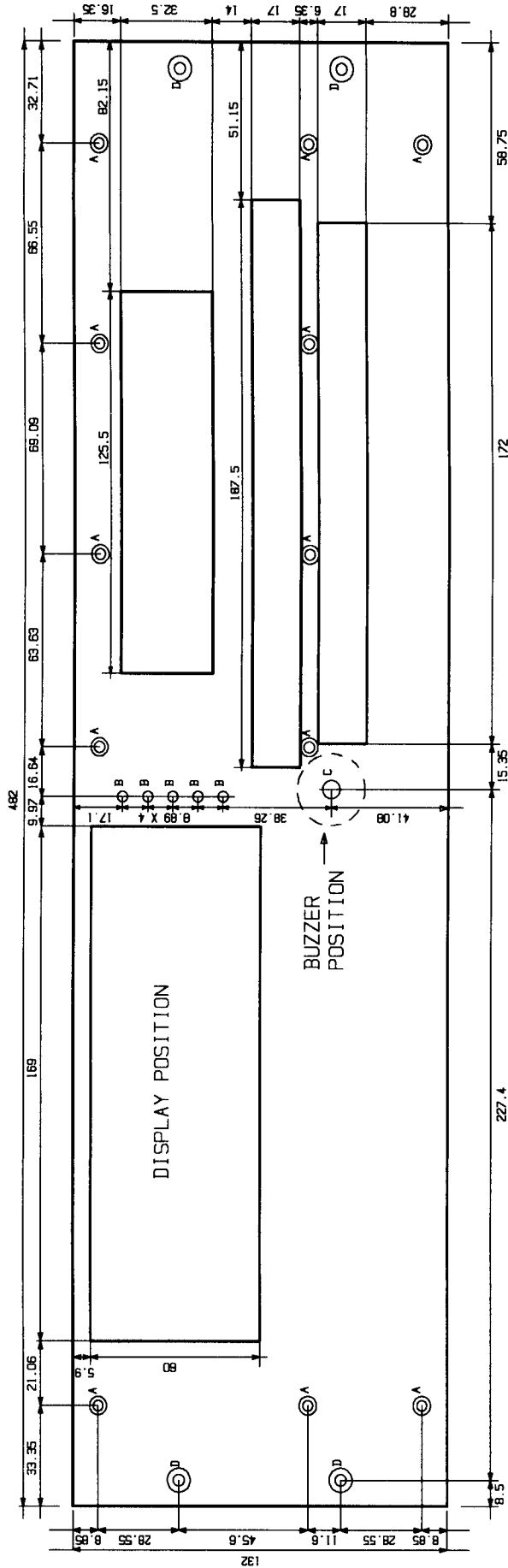

HOLES A : 12 HOLES FOR FIXING THE PCB TO THE FRONT PANEL 3.5 mm
 HOLES B : 7 HOLES ON FRONT PANEL CORRESPONDING WITH LEDS - 3.5 mm
 HOLE C : 1 HOLE ON FRONT PANEL CORRESPONDING WITH THE BUZZER - 6 mm
 HOLES D : 4 HOLES ON THE FRONT PANEL FOR FIXING THE KEYBOARD TO THE MACHINE, 4.5 mm WITH 8 mm COUNTERSINKING

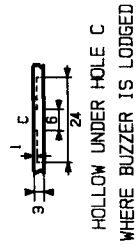

HOLLOW UNDER HOLE C
 WHERE BUZZER IS LOGGED

MEASUREMENTS ARE IN mm

MATERIAL: ALUMINIUM 3mm THICK

FIG. 17 : COVER OF KEYBOARD T/MED1 240790-098 EXCLUSIVE VERSION

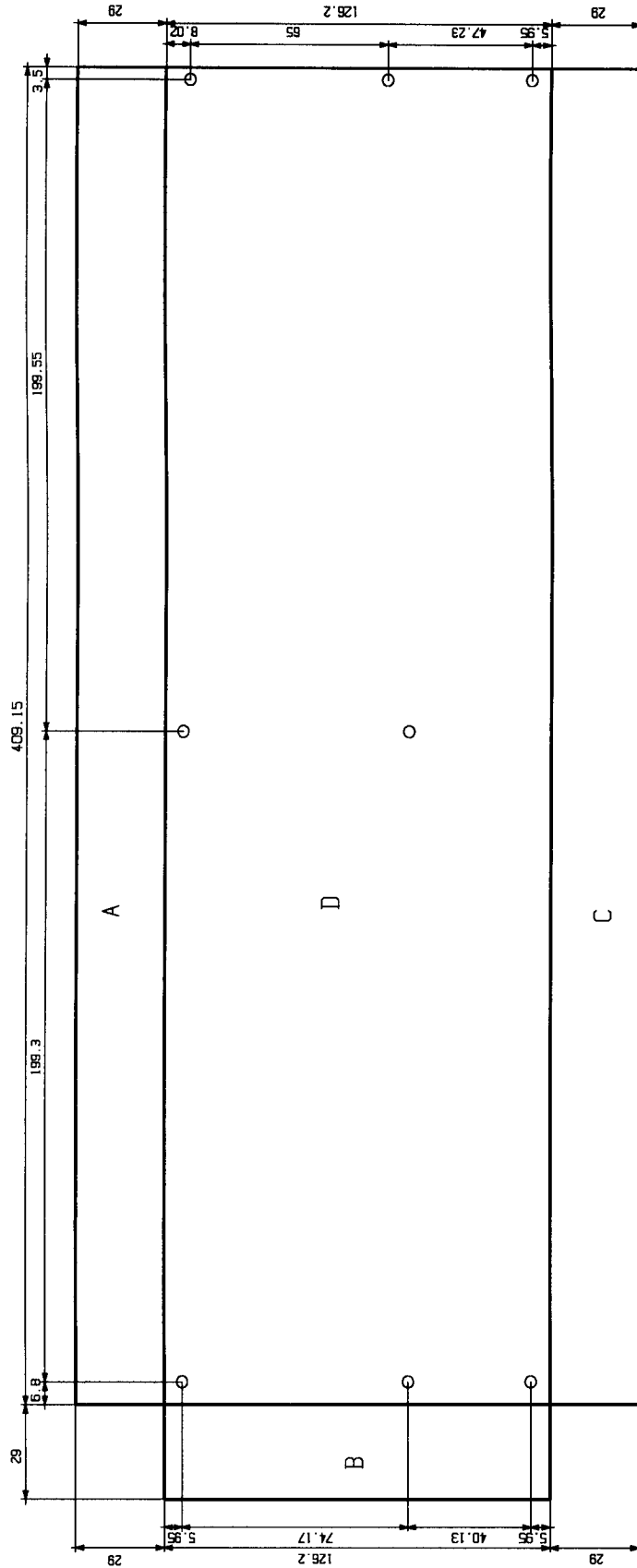

ALL HOLES HAVE 3.5 mm DIAMETER
 SIDES A, B AND C MUST BE FOLDED TO 90 DEGREES IN ORDER TO FORM THE COVER
 MATERIAL : ALUMINIUM 1.5 mm THICK
 ALL MEASUREMENTS ARE IN mm AND ARE INTERNAL, WHEN THE ARTICLE IS
 FINISHED WITH EDGES FOLDED TO 90 DEGREES

FIG.19 : MECHANICAL DRAWING AND FOOTAGE OF CONNECTORS ALSMC09

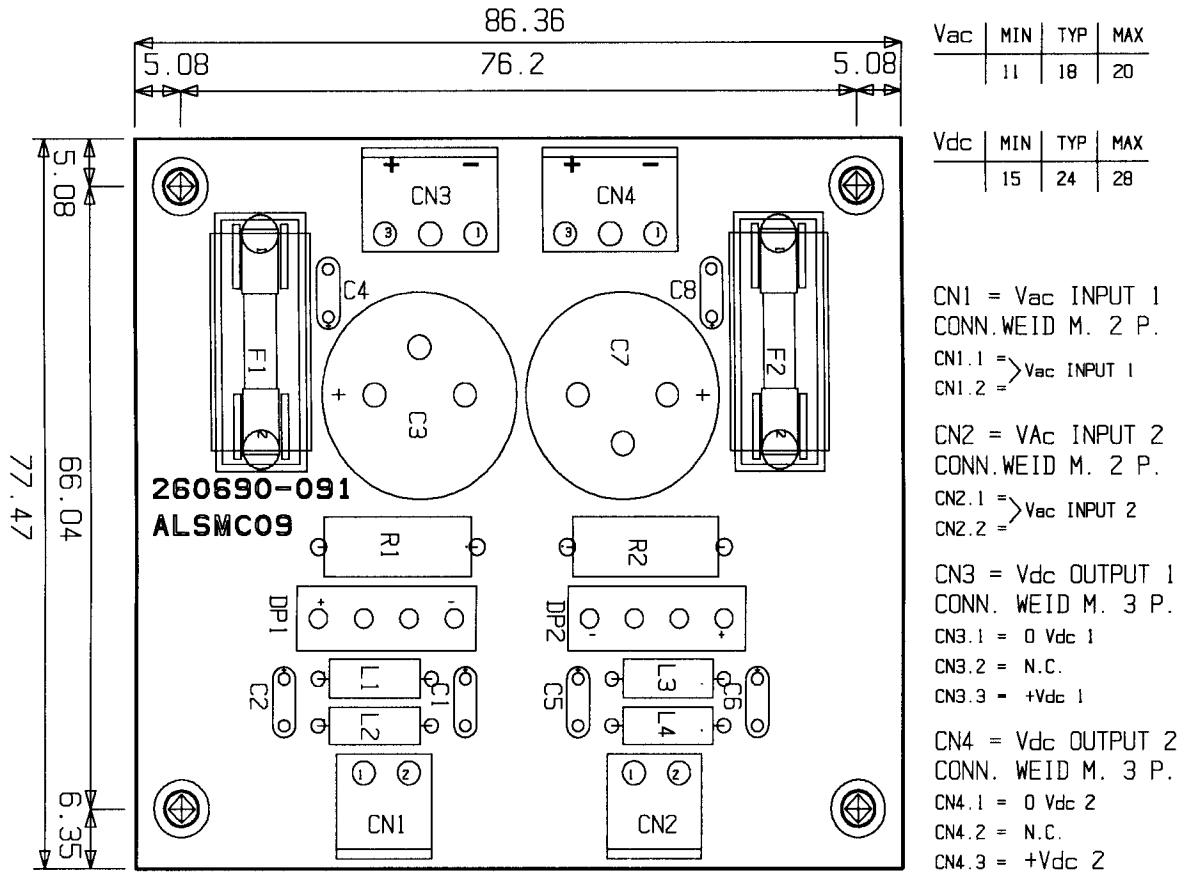

FIG.20 : MECHANICAL DRAWING AND FOOTAGE OF CONNECTOR CK-SMCO1

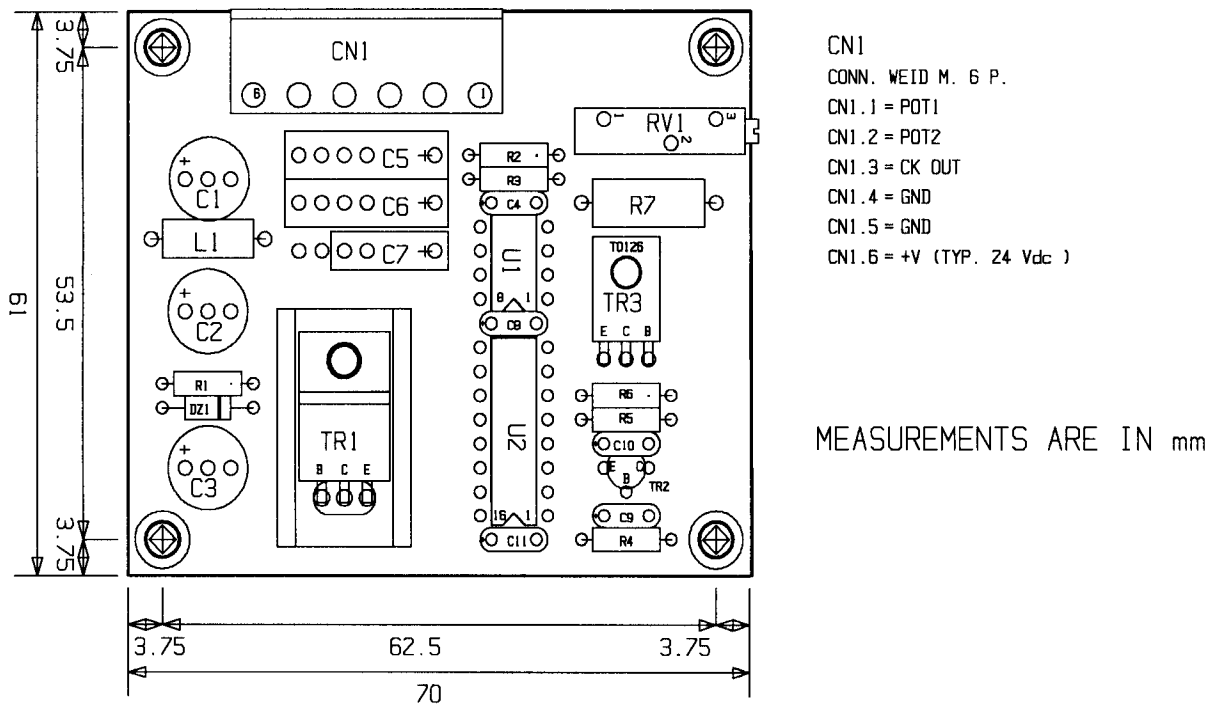

FIG.21 : MECHANICAL DRAWING OF WINGED DISSIPATOR FOR SUPPLEMENTARY DISSIPATOR KIT SMC01-09

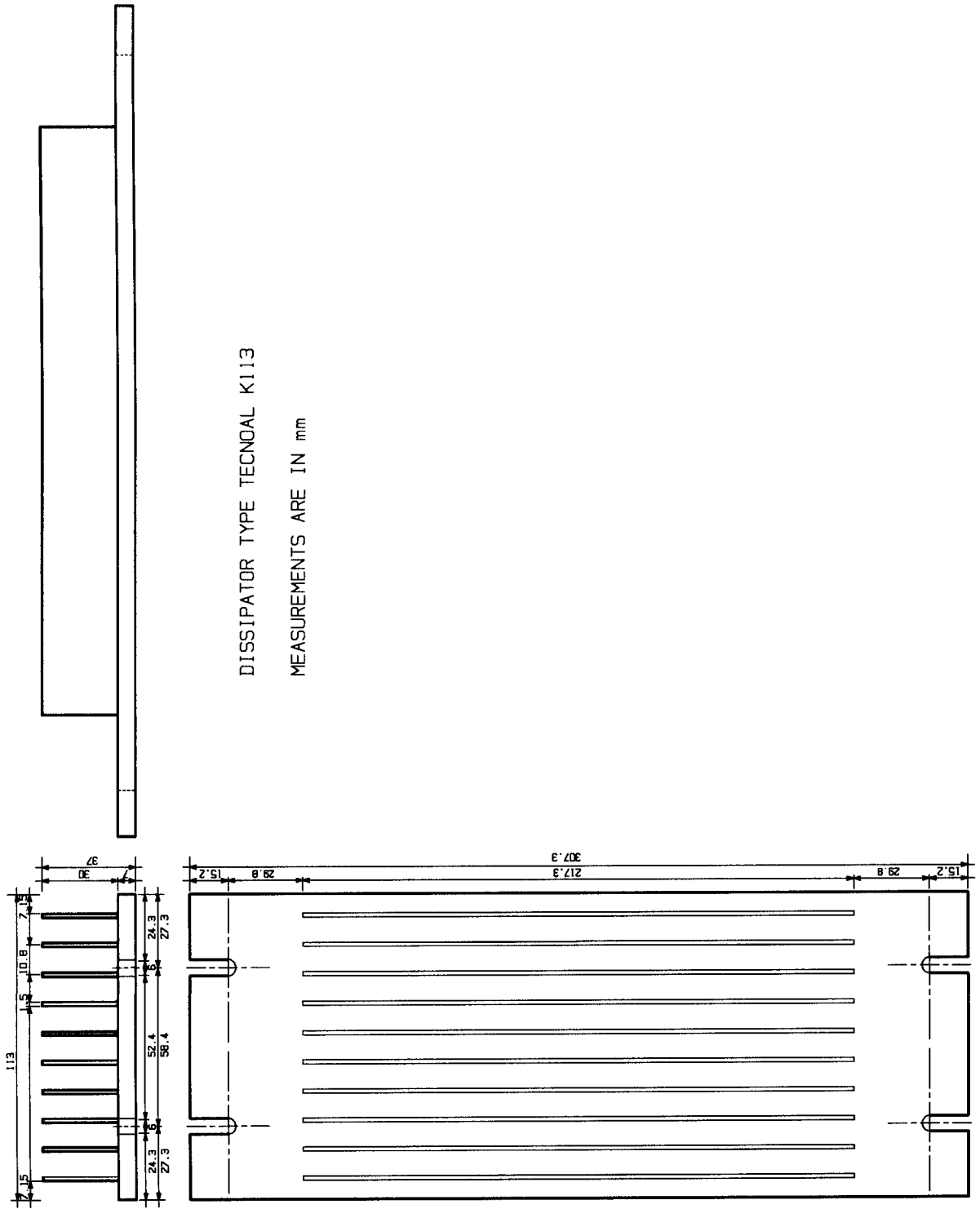
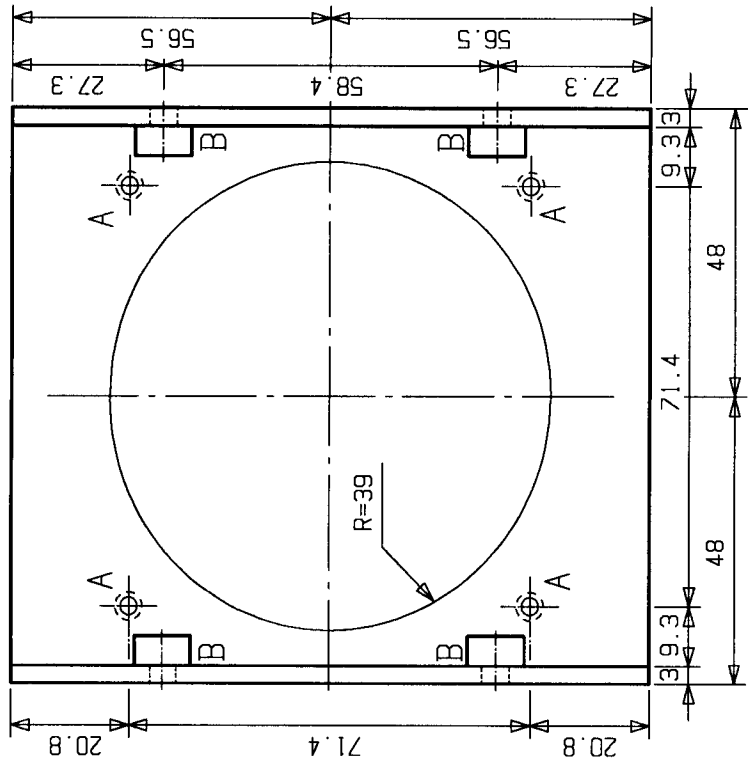
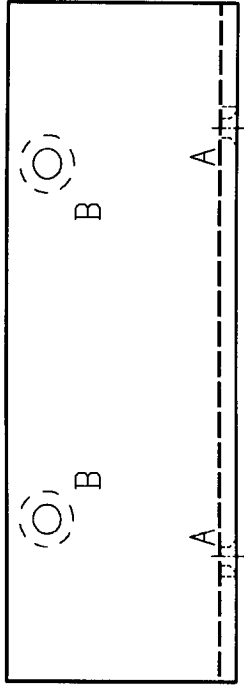
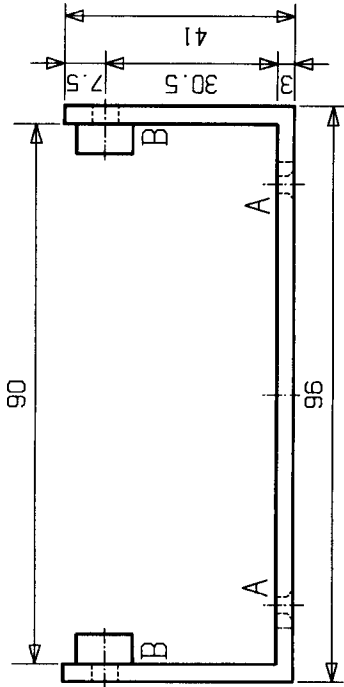

FIG. 22 : MECHANICAL DRAWING OF SUPPORT CLAMPS SUPPLEMENTARY DISSIPATOR
KIT FOR SMC01-09



A : 4 COUNTER-SUNK 3.5 MM HOLES
B : 4 SMA TYPE COLLETS
MATERIAL : 3mm ALUMINIUM
MEASUREMENTS ARE GIVEN IN mm

FIG. 23 : HOW TO ASSEMBLE THE SUPPLEMENTARY DISSIPATOR KIT FOR SMC01-09

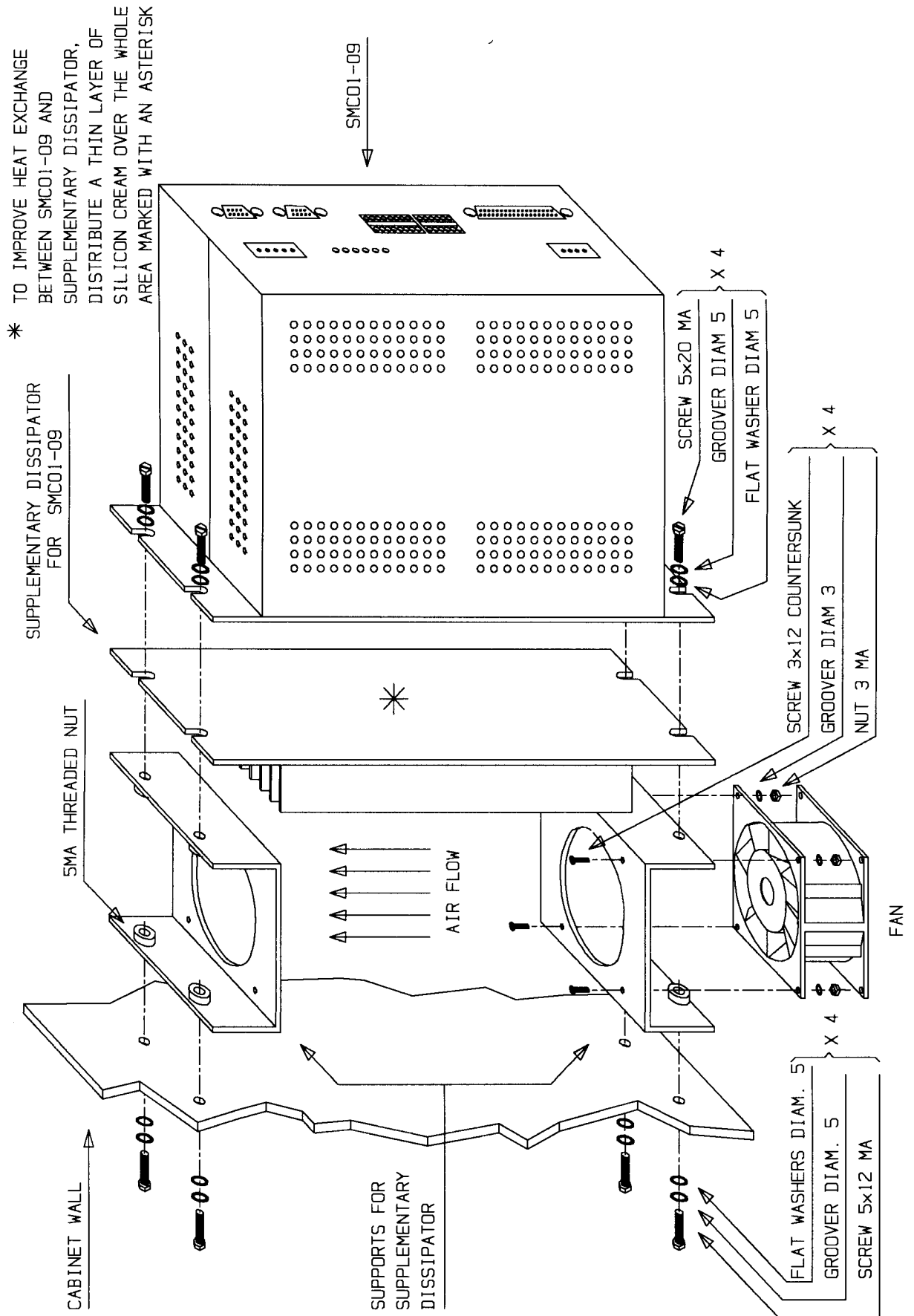

FIG. 24 : MEASUREMENTS OF SMC01-09 COMPLETE WITH SUPPLEMENTARY DISSIPATOR KIT
 MEASUREMENTS ARE IN mm

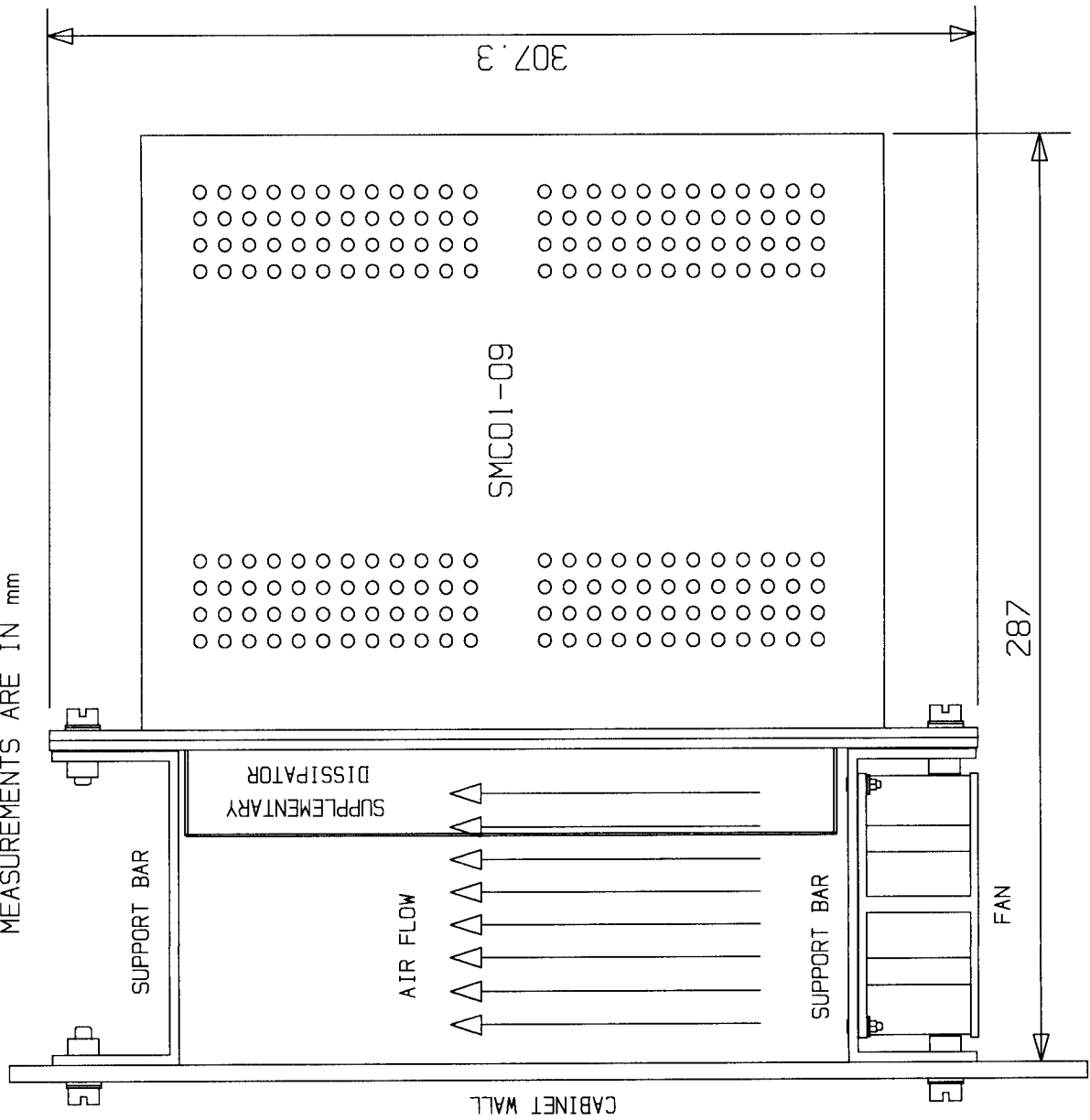
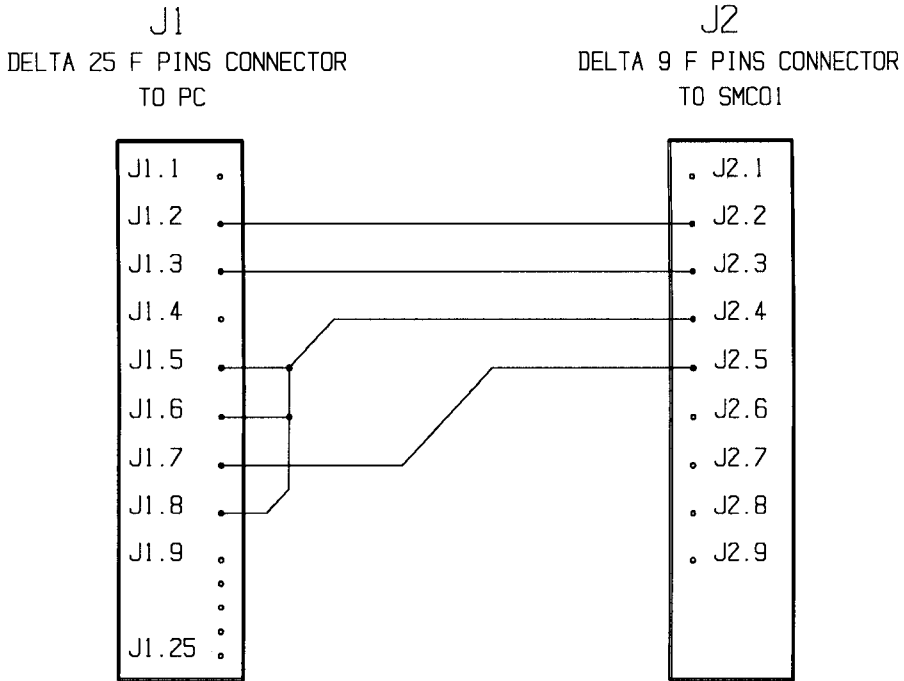
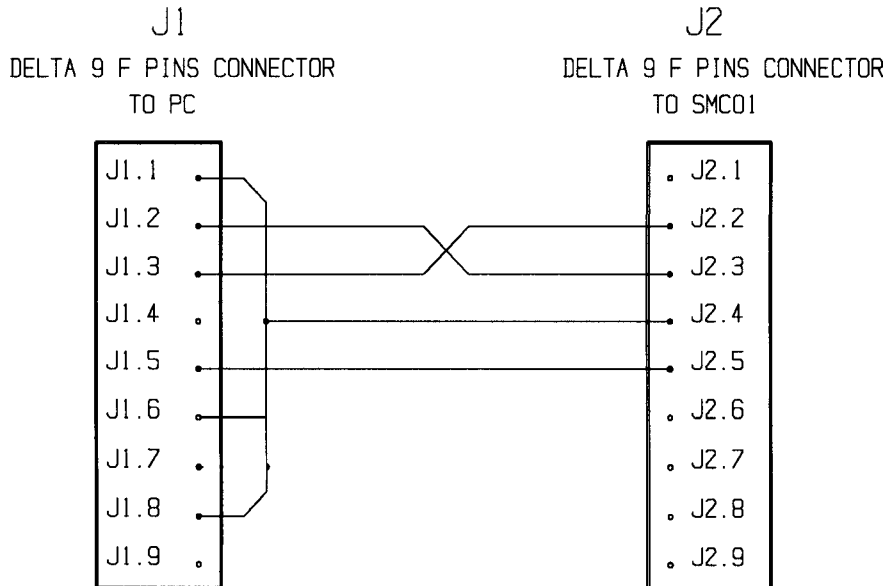

FIG.25 : WIRE BETWEEN PC AND SMC01-09

WIRE FOR PC WITH 25 PINS RS232



WIRE FOR PC WITH 9 PIN RS232



NOTE :

*** CHAPTER 4 ***

DESCRIPTION OF SOFTWARE

INDEX :

PARAGRAPH 4.1 :	INTRODUCTION TO SOFTWARE	p. 44
PARAGRAPH 4.2 :	XPRES	p. 44

4.1 INTRODUCTION TO SOFTWARE

The SMC01-09 systems are supported by software solutions able to satisfy all your requirements.

A program can be compiled by following two basic procedures:

- a) study of application (machine cycle) and compilation of a custom program by our software engineers;
- b) your own compilation of programs with the XPRES compiler.

4.2 XPRES

A software packet for MSDOS Personal Computers is used for programming the SMC01-09 systems. Complete guidance is ensured by a series of interrelated menus which all refer back to a XPRES supervisor menu, enabling access to the following main programming functions, through the function keys of the PC :

- EDIT for writing a new program and modifying an existing program by means of an EDITOR, resident or chosen by the user.
The new program is written using the symbolic Macroinstructions provided by the XPRES interpreter, applicable to variable data and unadressable constants with symbolic labels.
- PRINT prints the program in memory, giving a complete documentation of the work done.
- COMPILE checks that the syntax of the new program is correct, and transforms it into object program.
- PROGRAM enables input of the object program into the SMC01-09 system, monitoring transmission.
- DEBUG is a high-level function enabling break-points to be inserted between the lines of macroinstructions and TRACE is for checking the flow of the program that the CPU is processing and the state of the variables to be monitored, some of which can be modified immediately (outputs, counters, timers).

SEQUENTIAL PROGRAMMING

The programming philosophy of the system is oriented towards the "STEP".

Many process controls are of a sequential nature: the machine to be monitored performs one action after another on the basis of preset conditions that may include waiting for probe signals, timers and counters running out, etc...

Therefore the sequence of control is defined by a series of actions carried out according to given conditions.

A sequential language for solving monitoring problems enables undesired interactions between the branches of the program to be avoided (for example if a parallel language is used) and minimizes execution times, optimizing the machine's performance, as only a small part of the program is used at each step of the monitoring cycle.

The system is designed to facilitate the solution of sequential problems, using a sequential language.

The software packet includes :
XPRES. EXE

XPRES. EXE :

software dedicated to the compilation and transmission of the user's management program.

It also includes a basic Editor for writing macrosinstruction software, a window for direct communication with the SMC01-09 system.

The following are all the options available:

- (F1) = Help window for base editor commands
- (F2) = Stores user program in the directory used.
- (F3) = opens-closes the file XPRES.NCO. This option is used only in the window of direct communication with the SMC01-09 system (F5).
- (F4) = compiles the user program.
- (F5) = activates the window for direct communication with the SMC01-09 system (F5).
- (F6) = compiles and then transmits the program via RS232, from PC to SMC01-09 system.
- (F7) = temporarily exits from the operative system (interface DSO).
- (F8) = proceeds temporarily to an editor chosen by the user during the Set-up phase.
- (F9) = displays on the right hand side of the screen the window containing the file with .NLA extension
- (F10)= sets configuration of communication and the alternative editor.

TO BEGIN?

To enter XPRES the filename XPRES must be typed, where filename is the name of the program written by the user and made up of macroinstructions.

Having written the above mentioned command and pressed return (cr), the initial window of the XPRES compiler will appear.

N.B.: the filename can also be empty.

FILES WITH EXTENSIONS .CMD, .NLA, .NCO

The user program is written in a file with .CMD extension and consists of:

- macroinstructions with a minimum of 0 and a maximum of 3 topics. The topics refer to constant or variable values, or symbolic labels.
- Alphanumerical labels (max. 8 characters).
- Comments, if preceded by *
- Comments on macroinstructions, on the right of the macroinstructions themselves.

Another two files:.NLA,.NCO are obtained by using compilation (F4) from the file with .CMD extension.

All the comments are eliminated in the file with .NLA extension, alphanumerical labels are substituted by absolute references (line numbers), each macroinstruction is identified by a line number and every instruction possesses a system identifier (default value 00).

The file with .NLA extension is displayed when the function key F9 is pressed.

The file with .NCO extension is obtained from file.NLA. Inside the character "stx" is placed at the head of every macroinstruction, and is identified by the code ASCII 02, and the character "etx" is placed at the end, and is identified by the code ASCII 03.

This file is the one that is really transmitted to the SMC01-09 system.

The correct syntax understood by the interpreter resident on system SMC01-09 is contained in it.

MACROINSTRUCTIONS

The interpreter of the macroinstructions resident on the SMC01-09 system may be found in one of the 3 phases described below:

- 1) programming phase
- 2) phase of direct execution of commands
- 3) execution phase of program memorized

Each phase remains active until the following change of phase.

1) PROGRAMMING PHASE

This phase is activated by command "p", which tells the interpreter that from that moment onwards every macroinstruction must be stored in the system memory at the current line number.

Every time a macroinstruction is memorized, a line counter is incremented.

Generally there are 3 fundamental instructions over the user program:

- pe = starts the phase of direct execution of the commands
- nw = zeroes the line counter inside the interpreter
- p = starts the programming phase

The PC transmits the user program in a sequential mode, and the interpreter program resident on the SMC01-09 system receives and interprets sequentially all instructions.

By analysing the proposed example, note that the first macroinstruction that reaches the interpreter is "pe" which puts it in the direct execution phase, in other words from that moment each macroinstruction is executed immediately, and the "nw" command is in fact not memorized, but executed immediately.

Lastly the interpreter, having decoded the command "p", starts the programming phase.

2) PHASE OF DIRECT PROGRAM EXECUTION

This phase is activated by the command "pe", which tells the interpreter that every command must be executed immediately from that moment.

This enables the user to make line traces, line edit, set-reset outputs, move the motor, tron-troff program check etc...

3) EXECUTION PHASE OF MEMORIZED PROGRAM

This phase is activated by the command "es", which executes the memorized program starting from the set line.

Example :
 move the motor at a continuous rate without step limits,
 until input 0 stays open.

If input 0 closes, stop the motor and set output 1.

```

      cf      1000      set phase current = 10 A
      pa      800      steps/rev. = 800
      fb      500      minimum frequency = 500 Hz
      fm      4000     maximum frequency = 4000 Hz
      np      300      number steps ramp = 300
      cal                      calculates linear ramp
*
      v      3000      speed of movement = 3000 Hz
      mcv+                      starts the motor
labl  fir      2048   labl  wait for closed input
*
      sm                      if input closed
      so      1024     set output 1

```

LIST OF MACROINSTRUCTIONS XPRES INTERPRETER

The following is a list of the most important macroinstructions provided by the XPRES interpreter.

```

np      = sets number steps motor ramp
cal     = calculates motor ramp
p       = sets programming phase
eds     = line edit
es      = program execution
fm      = sets maximum frequency motor ramp
sds     = sets timer
itd     = reads timer
so      = sets output/s
ro      = resets output/s
fb      = sets minimum frequency motor ramp
fir     = tests whether input open
fis     = tests whether input closed
mv+     = moves the motor ahead of the set value
mv-     = moves the motor below the set value
j       = jumps to label
v       = sets movement speed
mvc+    = moves motor ahead continuously without step limit
mvc-    = moves motor back continuously without step limit
mvq     = moves motor up to set quota
sm      = immediately stops the motor with reduced current
smp     = stops the motor after the set number of steps
cf      = sets motor current phase
ei      = sets the number of impulses /rev. of the encoder
pa      = sets the motor's steps per revolution
tmp     = transforms mm in motor steps

```

tmi = transforms mm in encoder impulses
tr = line trace is = sets system identifier
fu = tests if counter value corresponds to set value
fa = tests if the counter value is lower than the set value
fi = tests if the value of a counter is higher than the set value
ic = increments counter value
dc = decreases counter value
vc = displays counter value on dedicated keyboard
sqv = reads motor rate and sets it in a variable
vq = displays rate level on dedicated keyboard
pe = sets direct execution phase
fim = checks whether motor has stopped
xv = exchanges the content of two variables
js = jumps to subroutine
sv = sets numerical value in variable
vv = displays the content of the variable
ivu = checks whether the value of a variable is equal to the set value
iva = checks whether the value of a variable is higher than the set value
ivi = checks whether the value of a variable is lower than the set value
icv = increments the numerical value of the variable
dcv = decreases the numerical value of the variable
mn = displays a message on the dedicated keyboard
dt = enables all the keys of the dedicated keyboard
it = disables all the keys of the dedicated keyboard
dtn = disables key/s of the dedicated keyboard
atn = enables key/s of the dedicated keyboard
avv = adds the content of two variables
as = motor movement with/without electrical axis
pd = sets inclination of motor ramp
lce = reads encoder value and sets it in variable
vit = displays the whole memorized program
vdr = displays duration of the deceleration ramp
sl = sets led on the dedicated keyboard
rl = resets led on dedicated keyboard
sze = tests zero encoder

SOFTWARE DEVELOPMENT

The library of macroinstructions above is an example for reference, as the XPRES software packet is in continuous evolution, to simplify object program writing as much as possible and further condense its structure.

NOTE :

*** CHAPTER 5 ***

INSTALLATION, USE AND LIMITATIONS

INDEX :

PARAGRAPH 5.1:	MECHANICAL INSTALLATION	p. 52
PARAGRAPH 5.2:	FRONT PANEL DESCRIPTION(SIGNAL LEDS, CONNECTORS, SILK-SCREEN PRINTING AND INTERVENTION OF PROTECTIVE DEVICES	p. 52
PARAGRAPH 5.3:	CHARACTERISTICS OF INPUTS AND OUTPUTS	p. 57
PARAGRAPH 5.4:	STARTING UP	p. 61
PARAGRAPH 5.5:	DIAGNOSIS OF FAILURES	p. 61

5.1 MECHANICAL INSTALLATION

Figure 4 on page 16 shows how the two cards SMC01 and MPP09 are fixed to the inside of the box on a single base where the heat generated by the power card is collected.

The SMC01-09 system was designed to make mechanical installation extremely simple, as only 4 screws are needed for fixing.

Take care however that the system is fixed to a suitable surface.

It will have to act as dissipator of the heat sent out from the base.

It must however be metallic (or material that is a good heat conductor) and large enough to ensure heat exchange.

The quantity of heat produced by the MPP09 power card depends on the phase current that has been set and how heavy a machine cycle has been programmed. If the surface on which the SMC01-09 system is to be fixed does not have these requisites and it is not possible to introduce a flow of forced air, EVER can supply a SUPPLEMENTARY DISSIPATOR KIT (presented in chapter 3 OPTIONS AND ACCESSORIES).

In figure 26 we can see the measurements of the base with the measurements for correct alignment of the holes for fixing the system in the electricity cabinet.

Complete box measurements are also given.

To allow optimal heat exchange between the base of the SMC01-09 and the fixing surface, we recommend that a thin layer of silicon cream be spread on the base before fixing.

5.2 DESCRIPTION OF THE FRONT PANEL (SIGNALLEDS, CONNECTORS, SILK-SCREEN PRINTING AND INTERVENTION OF PROTECTIVE DEVICES)

Figure 27 shows the front panel of SMC01-09.

There are 5 connectors through which the system is interfaced with the exterior.

The footage and the different type of connectors used makes wrong connection impossible (for example the RS232 wire cannot be inserted in the ENCODER connector etc.).

Fig. 28 the connector pin out is shown.

Silk screen printing enables immediate interpretation of the led signals.

As for the INPUTS/OUTPUTS leds, one led on means that one input/output is excited.

S1 and S2 are service leds managed by software and give information on the state of the CPU.

FIG.26 : DIMENSIONS AND MEASUREMENTS OF SYSTEM SMC01-09

MEASUREMENTS ARE IN mm

BACK BASE WITH WIRES FOR FIXING SCREWS MEASUREMENTS OF BOX FOR SMC01-09 SYSTEM

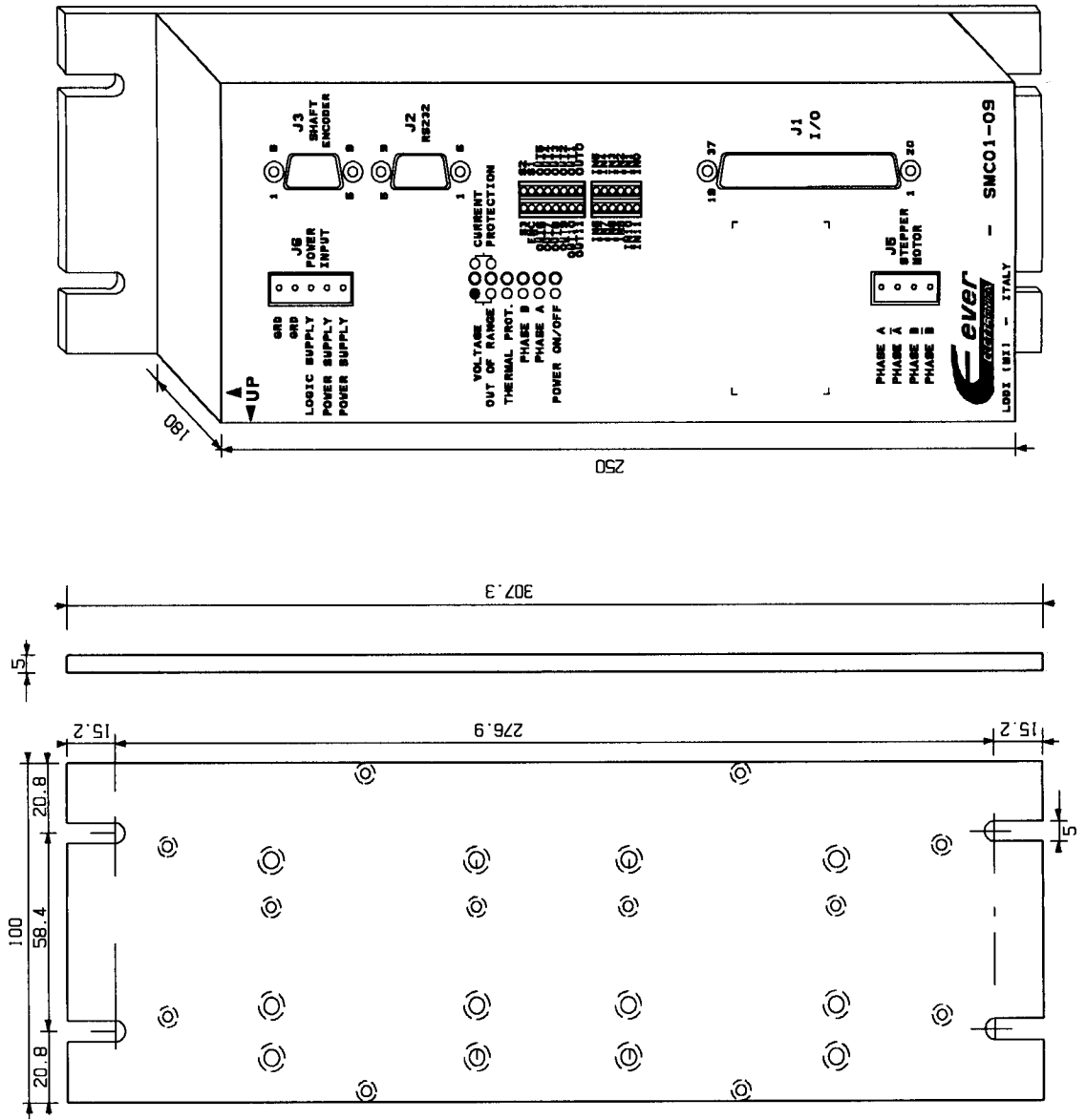

FIG.27 : FRONT PANEL OF SMC01-09 (SIGNAL LEDES AND SILK SCREEN PRINTING)

N.B. : WHEN MOUNTING SMC01-09 SYSTEM POSSIBLE UP SIDES ARE INDICATED BY MEAN OF "UP ARROWS". SUCH MOUNTING POSITIONS ARE NECESSARY TO DISSIPATE HEAT GENERATED BY MPP09 POWER BOARD AND FOR NO REASON CAN BE OMITTED

○ LED ON
● LED OFF

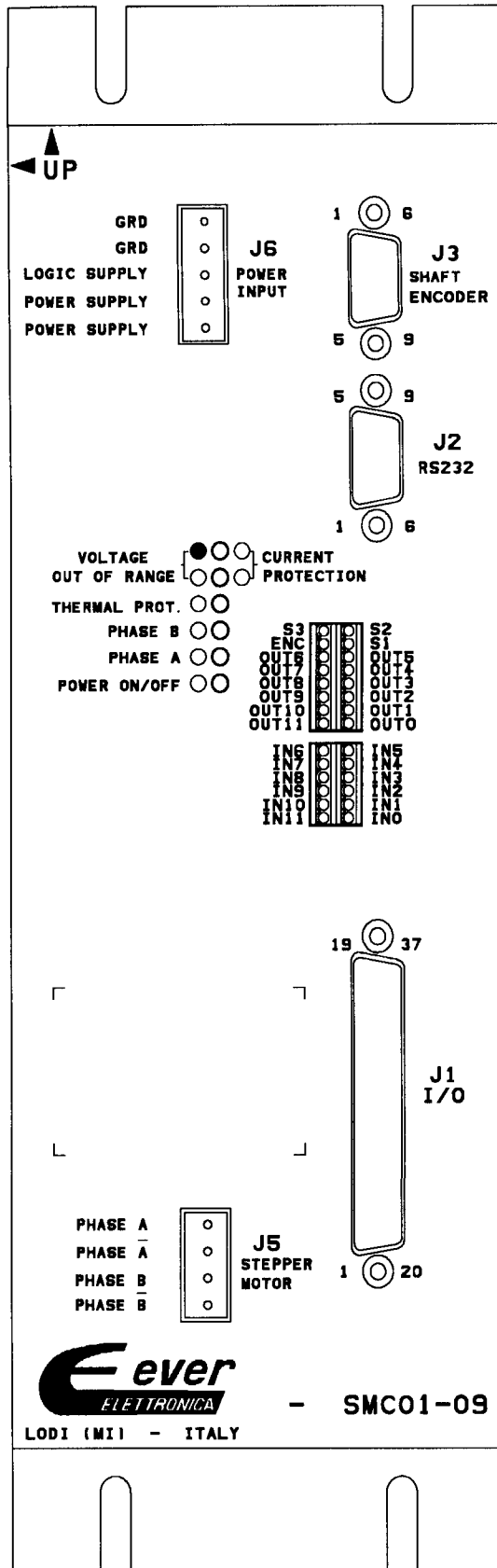

FIG. 28 : PIN-OUT CONNECTORS SYSTEM SMC01-09

J1 (I/O) 37 MALE PINS

1	=	IN0	⏏	GRD
2	=	IN1		
3	=	IN2		
4	=	IN3		
5	=	IN4		
6	=	IN5		
7	=	-S		
8	=	+S		
9	=	SYNC		
10	=	-Z		
11	=	ZERO		
12	=	OUTS1		
13	=	OUT0		
14	=	OUT1		
15	=	OUT2		
16	=	OUT3		
17	=	OUT4		
18	=	OUT5		
19	=			V+ (24 Vdc) EXT.
20	=			⏏
21	=			GRD
22	=	IN6		
23	=	IN7		
24	=	IN8		
25	=	IN9		
26	=	IN10		
27	=	IN11		
28	=	+Z		ZERO
29	=	+12Vdc (*)		
30	=	VSS		
31	=	OUT6		
32	=	OUT7		
33	=	OUT8		
34	=	OUT9		
35	=	OUT10		
36	=	OUT11		
37	=			V+ (24 Vdc) EXT.

J2 (RS232) 9 PINS MALE

1	=	
2	=	RxD
3	=	TxD
4	=	DTR
5	=	GND
6	=	
7	=	-8vVdc (x TVME01 -13v)
8	=	+8vVdc (x TVME01 +13v)
9	=	+5vVdc

J5 (MOTOR) 4 MALE PIN WEID

1	=	PHASE B	GREEN - WHITE/BLACK
2	=	PHASE B	ORANGE - WHITE/GREEN
3	=	PHASE A	BLACK - WHITE/RED
4	=	PHASE A	WHITE - RED

J3 (ENCODER) 9 FEMALE PINS

1	=	-Z	ENCODER PNP
2	=	+Z	ZERO ENCODER
3	=	nh	ZERO SUPPLY
4	=	nh	ZERO SUPPLY
5	=	+12Vdc	ENCODER SUPPLY (*)
6	=	-B	INPUT PHASE B
7	=	+B	INPUT PHASE B
8	=	-A	INPUT PHASE A
9	=	+A	INPUT PHASE A

J6 (SUPPLY) 5 MALE PINS

1	=	V.IN	VOLTAGE SUPPLY POWER
2	=	V.IN	75 Vdc - 150 Vdc
3	=	V.IN LOGIC	VOLTAGE SUPPLY LOGIC
4	=	GRD	75 Vdc - 150 Vdc
5	=	GRD	COMMON POWER / LOGIC

(*) ENCODER SUPPLY (+12 Vdc STABILIZED) IS DERIVED FROM EXTERNAL V+ (24 Vdc) SUPPLY

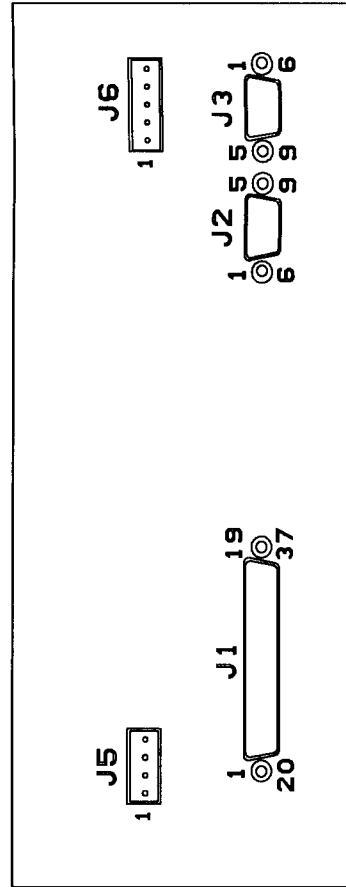
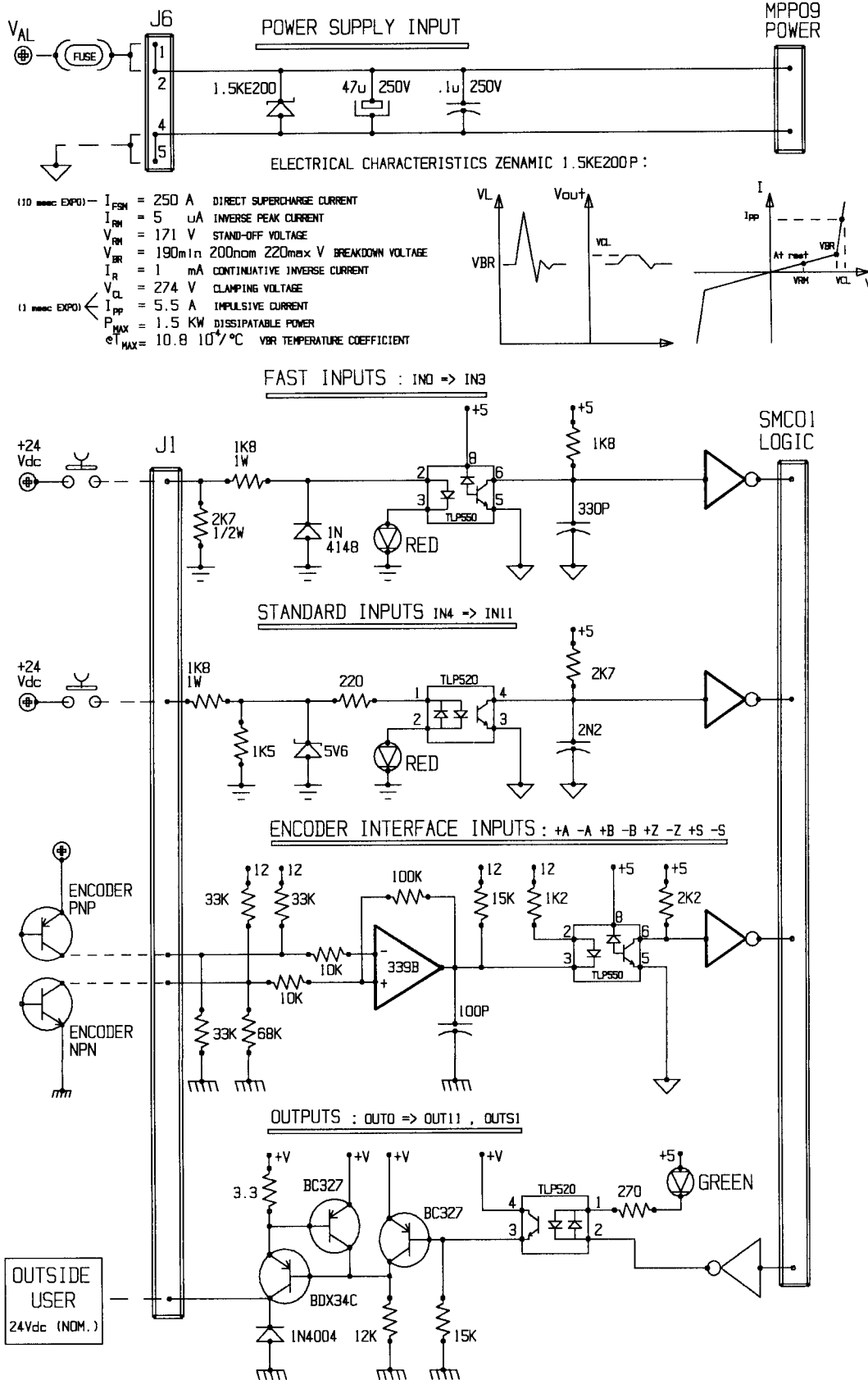

FIG.29 : CHARACTERISTICS OF INPUT OF POWER AND IN/OUT SUPPLY



The signal S1 is also carried to connector 1/0 J1 pin 11 as service output called OUTS1.

Led S3 is at the disposal of the encoder and informs it of the passage of the Zero encoder.

The first 3 leds of the second series give information as the protective devices come into operation.

In particular the combination of the first two leds shows when the OVER-UNDER VOLTAGE or the protective devices in CURRENT have been activated.

The third led signals when thermal protection is activated.

There are two types of thermal protection: the main one that is comes into use when the temperature of the base reaches 75C and another that comes into operation when the temperature inside the box reaches 55 C.

The protections function in different ways: when any of the current protections, motor brake and main thermal protective devices are set off, the system stops and it must be switched off and then restarted.

When the protective device against over-under voltages and against over-heating inside the box, the system is stopped and automatically restarts when the parameters (feed voltage and temperature inside the box) fall back within the correct limits.

Heat protection "inside the box" has no signal led but is indicated by the over-under voltage protective led.

5.3 INPUT AND OUTPUT CIRCUIT CHARACTERISTICS

These are shown in figure 29.

The input of power supply is protected by a TRANSIL zener diode that also eliminates any interference.

For correct dimensioning of the system's outside network, we indicate the electrical characteristics of the TRANSIL zener 1.5KE200P and recommend that the notes on the feeder section in figure 30B be followed with particular care, especially those regarding the fuses.

The external fuse ensures protection of the MPP09 power card even in the event of wrong connection of supply cables.

Figure29 shows the circuit characteristics of the 3 types of inputs and outputs.

Both are optoisolated.

The fast inputs and standard inputs have the same point of reference(earth),while the encoder inputs have the same point of reference as the outputs.

FIG. 30A : DIAGRAM OF CONNECTION TO SYSTEM SMC01-09

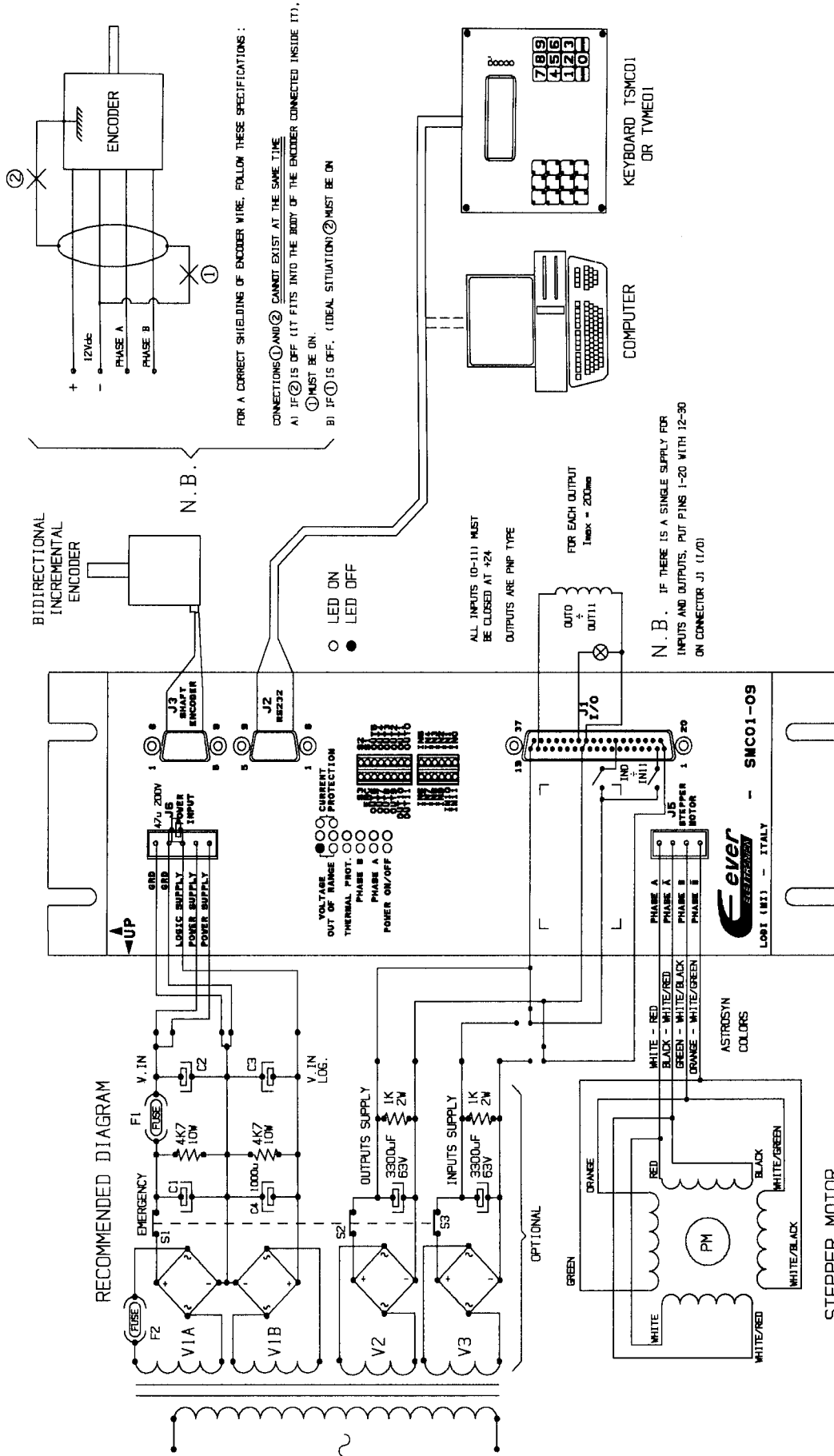

N.B. TO REVERSE MOTOR DIRECTION, JUST INVERT PHASES A OR B FOR EXAMPLE

WHITE - RED BLACK - WHITE/RED

FIG.30B : CRITERIA FOR DIMENSIONING THE FEEDER STAGE

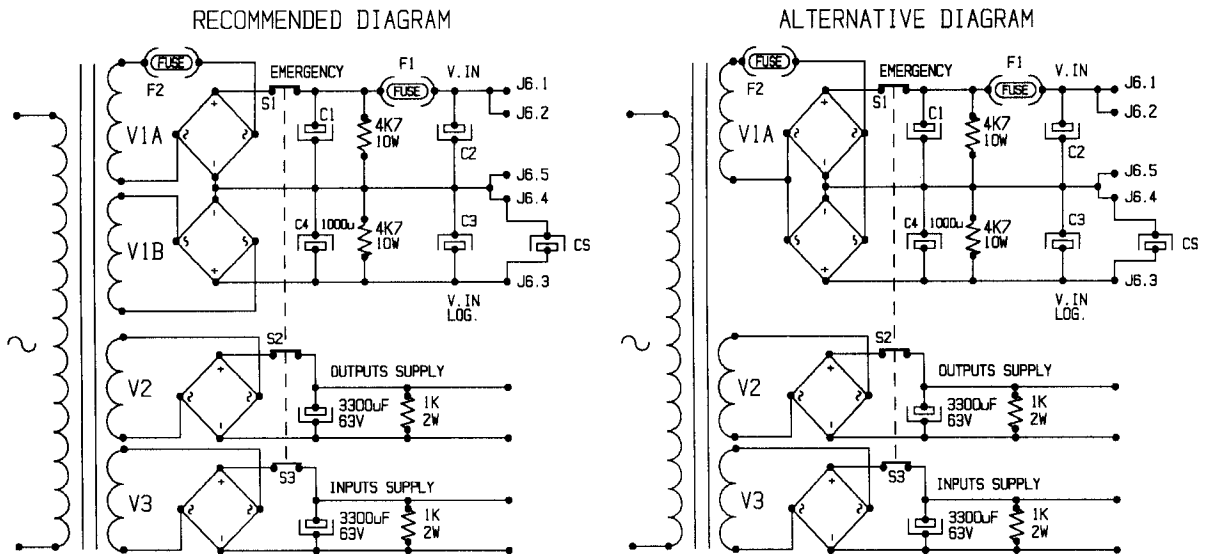

IT'S ALWAYS POSSIBLE TO DISCONNECT THE ALTERNATING VOLTAGES TO DIODE BRIDGE OF POWER V_{in} WITH TWO CONTACTS OF A REMOTE CONTROL SWITCH .

TO SWITCH-OFF COMPLETELY THE SYSTEM MUST BE PROVIDE A SWITCH ON THE PRIMARY WINDING OF THE TRANSFORMER.

THE TRANSFORMER MUST BE 1800 V_{max} (DEPENDING ON THE MOTOR AND THE LOAD APPLIED TO IT) .

VOLTAGES TO SECONDARIES MUST BE : $55V < V_{1A,B} < 125V$; $11V < V_2=V_3 < 20V$.

POWER SUPPLY TO SECONDARIES V2 AND V3 IS RESPECTIVELY: $PV_2 = 150VA_{max}$ $PV_3 = 50VA_{max}$

THE CONDENSER C1 MUST BE DIMENSIONED ACCORDING TO WHETHER THE LINE IS ONE- OR THREE-PHASE.

WITH ONE-PHASE LINE $\Rightarrow C1 = \frac{I_{media}}{2 F \Delta V}$ WHEN : I_{media} = AVERAGE CURRENT ABSORBED BY THE SYSTEM (SEE TABLE 1)
 F = NETWORK FREQUENCY 50/60 Hz
 ΔV = MAX RIPPLE ESTABLISHED (TYPICALLY $\Delta V = 5\% V_{in}$)

WITH THREE-PHASE LINE $\Rightarrow C1 = \frac{I_{media}}{6 F \Delta V}$

THE ELECTRICITY SUPPLY WIRES MUST BE 3mm² IN DIAMETER, IF MORE THAN 2.5 m THE SUPPORT CONDENSERS MUST BE PROVIDE WITH VALUE :

$C2 = 2200 \mu F$; $C3 = 470 \mu F$

WE ALSO RECOMMEND THAT A 47 μF FILTER CONDENSER (CS) BE CONNETTED DIRECTLY TO PINS 3 ($V_{in LOG.}$) AND 4 OF THE SUPPLY CONNECTOR J6.

200 VL CONDENSER MUST BE USED. THE FUSE F1 HAS A VALUE EQUAL TO THE SET CURRENT PHASE MOTOR AND IT IS A RAPID FUSE.

THE F1 MUST BE PLACE NEAR THE SMO01-09 SYSTEM AND FOR NO REASON CAN BE OMITTED . THE FUSE F2 IS OPTIONAL AND HAS A VALUE OF 1.5 X F1

AS IT MUST ALSO SUPPORT THE LOAD CURRENT OF C1 AND C2 (C3 AND C4 ALSO IN ALTERNATIVE DIAGRAM).

TABLE 1 :

AVERAGE CURRENTS ABSORBED BY THE SYSTEM WITH MOTOR AT MAXIMUM SPEED AND NO LOAD ON SHAFT. WHEN THERE IS A LOAD THE SYSTEM ABSORBS MORE THAN THE VALUES SHOWN IN THE TABLE. THIS IS WHY THE FILTER CONDENSER MUST BE CALCULATED , ROUNDING OFF THE EXCESS VALUES CALCULATED.

I phase	I_{media} ($V_{in} = 120V$)
2.3 A	550 mA
5.6 A	1020 mA
7.5 A	1650 mA
10 A	2200 mA
12 A	2400 mA

TABLE 2 :

C1 VALUES RECOMMENDED ACCORDING TO PHASE CURRENT SET , VOLTAGE IN SUPPLY AND TYPE FO LINE (ONE- OR THREE-PHASE). WITH THE SAME PHASE CURRENT, FOR LOWER SUPPLY VOLTAGES HIGHER CAPACITY C1 IS NEEDED TO ENSURE A RIPPLE WITHIN 5% OF V_{in} . TAKE CARE IF THE SYSTEM IS USED WITH A V_{in} CLOSE TO THE MINIMUM LIMIT (75V) AS IT COULD DROP BELOW MINIMUM VALUE BECAUSEOF THE RIPPLE FROM ABSORPTION, AND SET OFF THE 'UNDER VOLTAGE' SAFETY DEVICE.

I phase	C1 (μF) WITH $V_{in} = 80V$		C1 (μF) WITH $V_{in} = 150V$	
	ONE-PHASE	THREE-PHASE	ONE-PHASE	THREE-PHASE
2.3 A	2200	680	1000	470
5.6 A	3300	1000	2200	1000
7.5 A	4700	2200	3300	2200
10 A	6800	2200	4700	2200
12 A	10000	3300	6800	3300

FIG.31 : CONNECTION OF MOTOR PHASES

BELOW WE CAN SEE THE COLOURS OF THE WIRES OF MOTORS ASTROSYN SERIES 23PMC, 34PMC AND THE CLAMP NUMBER FOR SERIS 42.

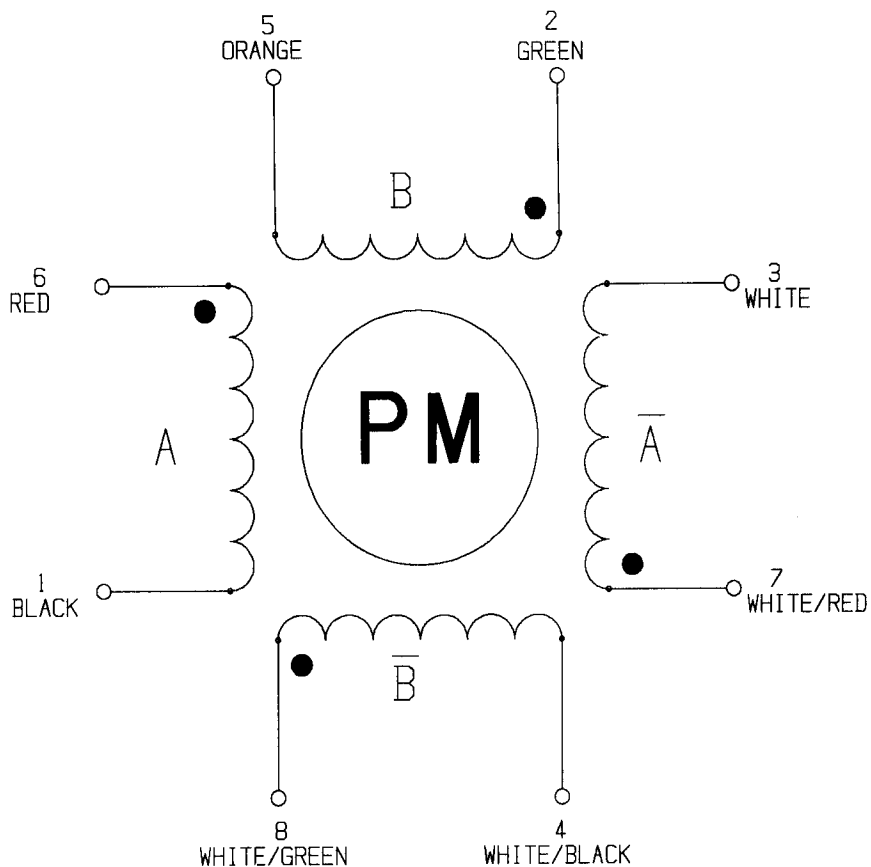

PARALLEL TWO-PIN CONNECTION

PHASE A : J5.4 = RED WITH WHITE	(6 WITH 3)	} PHASE A	NOTE : WHEN PHASES ARE CONNECTED IN PARALLEL TWO-PIN WAY, THE MOTOR IS ABLE TO OFFER BETTER SPEED PERFORMANCE NOM. CURRENT = PHASE CURRENT (MOTOR) X 1.41
PHASE \bar{A} : J5.3 = BLACK WITH WHITE/RED	(1 WITH 7)		
PHASE B : J5.2 = ORANGE WITH WHITE/GREEN	(5 WITH 8)	} PHASE B	
PHASE \bar{B} : J5.1 = GREEN WITH WHITE/BLACK	(2 WITH 4)		

SERIES TWO-PIN CONNECTION

CONNECT BLACK WITH WHITE (3 WITH 1)
AND ORANGE WITH WHITE/BLACK (5 WITH 4)

PHASE A : J5.4 = RED	(6)	} PHASE A	NOTE : NOM. CURRENT = PHASE CURRENT (MOTOR) X 0.7
PHASE \bar{A} : J5.3 = WHITE/RED	(7)		
PHASE B : J5.2 = WHITE/GREEN	(8)	} PHASE B	
PHASE \bar{B} : J5.1 = GREEN	(2)		

If it is deemed necessary to unite the references, this can be done through external wiring during the test phase or directly on the SMC01 card.

The particular configuration of the encoder interface inputs enables easy connection of NPN, PNP and PUSH-PULL encoders.

5.4 START UP

EVER supplies the SMC01-09 systems already set according to the client's requirements.

There is no need for manipulation inside the box except if authorized directly by EVER.

Figure 30A shows the diagram of the system connection, to complement the table in figure 28 that shows the pin-out of the connectors on the front panel.

The feeder stage that gives the logic and power Val must be dimensioned as specified in fig. 30 B.

Figure 31 contains the main diagram of a STEPPER motor and the notes needed to connect it correctly.

Before giving power, ensure that all connections have been made according to figure 28, that the feeder supplies the right voltage and that all connectors are perfectly inserted.

Give the power supply and check that:

- the green supply led is on
- the red leds Phase A and Phase B light up (at least one)
- the inputs/outputs are set according to instructions.

5.5 DIAGNOSIS OF FAILURES

-
- A) if after switching on, the GREEN led or any other led does not light up:
check that there is voltage supply
J6 pin 1,2,3 = Val
pin 4,5 = GND
 - B) if the RED light indicating VOLTAGE OVER THE LIMIT comes on after the system has been given the power supply: check that the voltage of supply is within the range indicated by specifications (75 to 180 Vcc).
 - C) if the leds indicating CURRENT PROTECTION come on after the system has received the supply: switch the system off, check that the connections to connectors have been made correctly and that there is no

power signal(motor phases, power supplies, GRD)being short-circuited.

Once the cause has been removed, restart the system.

If no LED comes on, check that the external fuse is not burnt.

Once this has been done, but the problem persists, the system can be considered to have broken down.

If the leds come on, this may be due to rapid rotation of the motor due to the load, even without power supply (motor brake).

- D) if the THERMAL PROTECTION led comes on after a few minutes of operation: it means that the dissipator cannot ensure the necessary heat exchange and the base of the system reaches a temperature of between 70 and 75 degrees centigrade.

This situation is a sign that the dissipating surface on which the system is fixed is inadequate or air circulation insufficient. Therefore a process of optimization must be carried out, using the SUPPLEMENTARY DISSIPATOR KIT for example.

The system also has a temperature sensor inside the box which intervenes as soon as the temperature rises above 55 degrees centigrade.

The reasons for the use of this protective device are the same mentioned for the main thermal protection device and the remedy is also the same.

N.B.: activation of the thermal protective device inside
=== the box is indicated by the leds for voltage over
the limit.

- E) If,when the inputs are excited they are not read by the system:
check that the signal leds for the excited inputs come on.
If not, check that there is separate voltage dedicated to the inputs and that connections to the connector I/O (J1) are correct.

- F) If the set outputs do not have any effect on the connected users :
check that the signal leds are set correctly and that there is isolated voltage dedicated to the outputs.
If there are no errors, check the connections to the connector I/O (J1) and to users.
Also check that the users connected to the outputs do not absorb more than 200 mA from each output so the protective device is not activated on the outputs.

The wiring around the system is extremely important, especially for applications that involve power switches near to the system or the electricity cabinet where it is lodged.

In these cases filtering systems on sources of interference such as power relays, remote-control switches, brush motors are compulsory.

A necessary precaution, but not sufficient for protection from interference, is to run the wires of the I/O, the RS232 interface and the Encoder interface along separate grooves and, if possible, far from those that carry power signals that cause interference.

If the instructions given here are not sufficient to solve your problems, please photocopy or detach the following insert and compile it fully.

Send it via FAX to EVER S.N.C. where the technical department will find a rapid solution to your problems and provide you with the technical support you require.

NOTE :

*** CHAPTER 6 ***

CONDITIONS OF VALIDITY OF THE WARRANTY

EVER devices are put through a thorough test phase including a RUN-IN and BURN-IN test in a climatic chamber with a temperature ranging from -5 to +50 degrees centigrade.

The warranty lasts a year starting from the date of consignment and covers any material or manufacturing fault.

It is no longer valid as soon as the procedures of installation are not complied with or in the event of manipulation by unqualified and/or unauthorized personnel.

The warranty is valid for material and labour free our laboratory.

The code stamped on the base gives the progressive series number and testing date.

NOTE :



20075 LODI (MI) - LOC S. GRATO Z.I. TEL 0371/412318 (4 LINEE R.A.)
 FAX 0371/412367

ATT. : TECHNICAL DEPARTMENT

RE. : TECHNICAL REPORT

SENDER :

SYSTEM CODE
 (NUMBER STAMPED ON THE BASE)

SHOW THE STATE OF SIGNAL LEDS BY BLACKENING THE LEDS THAT ARE NOT LIT.
 THE STATE OF THE LEDS MUST BE EVIDENT AS SOON AS THERE IS A MALFUNCTION,
 WITHOUT THE SYSTEM HAVING BEEN SWITCHED OFF

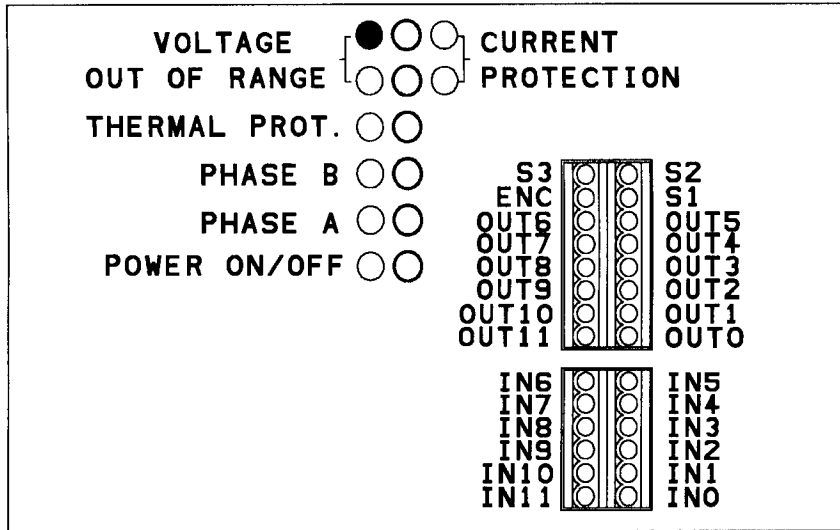

Vin	:	Vdc	INPUTS USED	: 0 <input type="checkbox"/> 3 <input type="checkbox"/> 6 <input type="checkbox"/> 9 <input type="checkbox"/>
COMMAND (SWITCHES)				1 <input type="checkbox"/> 4 <input type="checkbox"/> 7 <input type="checkbox"/> 10 <input type="checkbox"/>
SEPARATED Vin AND Vlog	: YES	<input type="checkbox"/>		2 <input type="checkbox"/> 5 <input type="checkbox"/> 8 <input type="checkbox"/> 11 <input type="checkbox"/>
	NO	<input type="checkbox"/>	TYPE OF COMMAND	
MOTOR CONNECTED	:	CONNECTED TO INPUTS	: BUTTONS/SWITCHES <input type="checkbox"/>
(TYPE AND BRAND)				RELAYS <input type="checkbox"/>
MOTOR PHASES	: PARALLEL	<input type="checkbox"/>		PHOTOCELLS <input type="checkbox"/>
	SERIES	<input type="checkbox"/>		FREQUENCY GENERATOR <input type="checkbox"/>
I PHASE	: 2.3 A	<input type="checkbox"/>		CONTRAVES <input type="checkbox"/>
	5.6 A	<input type="checkbox"/>		PLC <input type="checkbox"/>
	7.5 A	<input type="checkbox"/>	OUTPUTS USED	: 0 <input type="checkbox"/> 3 <input type="checkbox"/> 6 <input type="checkbox"/> 9 <input type="checkbox"/>
	10 A	<input type="checkbox"/>		1 <input type="checkbox"/> 4 <input type="checkbox"/> 7 <input type="checkbox"/> 10 <input type="checkbox"/>
	12 A	<input type="checkbox"/>		2 <input type="checkbox"/> 5 <input type="checkbox"/> 8 <input type="checkbox"/> 11 <input type="checkbox"/>
	OTHER	<input type="checkbox"/>	TYPE OF USER CONNECTED	
INCREMENTAL ENCODER	: YES	<input type="checkbox"/>	TO OUTPUTS	: RELAYS <input type="checkbox"/>
	NO	<input type="checkbox"/>		ELECTROVALVES <input type="checkbox"/>
IF THE TYPE IS SPECIFIED:	NPN	<input type="checkbox"/>		MAGNETS <input type="checkbox"/>
	PNP	<input type="checkbox"/>		PLC <input type="checkbox"/>
	PUSH-PULL	<input type="checkbox"/>		CONTRAVES <input type="checkbox"/>
ENCODER STEPS/REV	:	RS232 USED	: YES <input type="checkbox"/>
				NO <input type="checkbox"/>
MODEL	:	IF SPECIFIED	: TSMC01 <input type="checkbox"/>
				TVME01 <input type="checkbox"/>
BRAND	:		PC <input type="checkbox"/>
				OTHER <input type="checkbox"/>

BRIEF DESCRIPTION OF MALFUNCTION :

.....

.....

THE PROBLEM OCCURS	:	OCCASIONALLY	<input type="checkbox"/>
		REGULARLY	<input type="checkbox"/>
WHEN THE SYSTEM IS TURNED OFF AND ON AGAIN, THE PROBLEM	:	DISAPPEARS	<input type="checkbox"/>
		PERSISTS	<input type="checkbox"/>
THE PROBLEM OCCURS IN ONE PARTICULAR PHASE OF PROGRAM	:	YES	<input type="checkbox"/>
		NO	<input type="checkbox"/>

IF YES, SPECIFY IN WHICH PHASE :

.....





INDUSTRIAL ELECTRONICS

26900 LODI (LO) Zona Industriale - Loc. S. Grato.

Tel: +39/371/412318 Fax: +39/371/412367

E-Mails: Technical: evertech@tin.it

Market.: evermrkt@tin.it

Germany: Ever.Elettronica@t-online.de