

Service Manual

CD Stereo System

COMPACT
disc
DIGITAL AUDIO

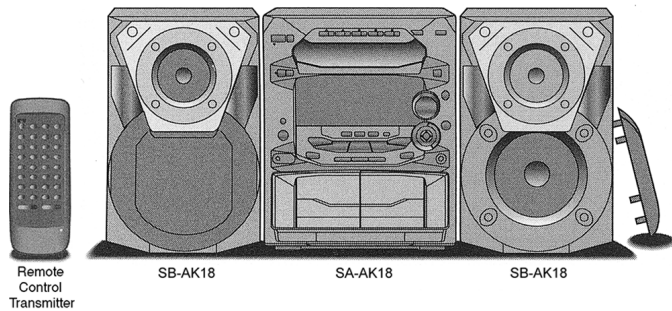

SA-AK18

Colour

(S)... Silver Type

Area

(GC)...Asia, Latin America, Africa and Middle Near East

(GN)...Oceania

TAPE SECTION :

AR2 MECHANISM SERIES

CD SECTION :

RAE0152Z-3 TRAVERSE DECK SERIES

Specifications

■ AMPLIFIER SECTION (GC area)

PMPO	1400 W
RMS power output	
THD 10%, both channels driven	70 W per channel (6 Ω)
Input sensitivity	
AUX	250 mV
MIC	0.7 mV
Input Impedance	
AUX	13.9 kΩ
MIC	680 Ω

■ AMPLIFIER SECTION (GN area)

RMS power output	
THD 10%, both channels driven	60 W per channel (6 Ω)
Input sensitivity	
AUX	250 mV
Input Impedance	
AUX	13.9 kΩ

■ FM TUNER SECTION

Frequency range	87.5 - 108 MHz (50 kHz steps)
Sensitivity	2.5 μV (IHF)
S/N 26 dB	2.2 μV
Antenna terminal(s)	75 Ω (unbalanced)

■ AM TUNER SECTION (GC area)

Frequency range	
MW	522 - 1629 kHz (9 kHz steps) 520 - 1630 kHz (10 kHz steps)
SW	3.200 - 7.350 MHz (0.005 MHz steps) 9.400 - 21.750 MHz (0.005 MHz steps)

Sensitivity

MW	
S/N 20 dB (at 999 kHz)	560 μV/m
SW	
S/N 20 dB (at 5.3 MHz)	35.5 μV/m

■ AM TUNER SECTION (GN area)

Frequency range	522 - 1629 kHz (9 kHz steps)
Sensitivity	
S/N 20 dB (at 999 kHz)	560 μV/m

■ CASSETTE DECK SECTION

Track system	4 track, 2 channel
Heads	
Record/playback	Solid permalloy head
Erasure	Double gap ferrite head
Motor	DC servo motor

Panasonic[®]

© 2000 Matsushita Electronics (S) Pte Ltd. All rights reserved. Unauthorized copying and distribution is a violation of law.

Recording system	AC bias 100 kHz	Power consumption in standby mode	
Erasing system	AC erase 100 kHz	Eco mode on	0.8 W
Tape speed	4.8 cm/s	Eco mode off	12 W
Frequency response (+3 dB, -6 dB at DECK OUT)		Dimensions (W x H x D)	270 x 330 x 310 mm
NORMAL (TYPE I)	35 Hz - 14 kHz	Weight	7.4 kg
HIGH (TYPE II)	35 Hz - 14 kHz	■ GENERAL (GN area)	
S/N	50 dB (A weighted)	Power supply	AC 230-240V, 50 Hz
Wow and flutter	0.18% (WRMS)	Power consumption	152 W
Fast forward and rewind time	Approx. 120 seconds with C-60 cassette tape	Power consumption in standby mode	
		Eco mode on	0.4 W
		Eco mode off	12 W
■ CD SECTION		Dimensions (W x H x D)	270 x 330 x 310 mm
Sampling frequency	44.1 kHz	Weight	6.9 kg
Decoding	16 bit linear	■ SYSTEM	
Beam source/wave length	Semiconductor laser/780 nm	SC-AK18 (GC)	Music Center: SA-AK18 (GC)
Number of channels	Stereo		Speaker: SB-AK18 (GC)
Frequency response	20 Hz - 20 kHz (+1, -2 dB)	SC-AK18 (GN)	Music Center: SA-AK18 (GN)
Wow and flutter	Below measurable limit		Speaker: SB-AK18 (GC)
Digital filter	8 fs		
D/A converter	MASH (1 bit DAC)	Notes:	
■ GENERAL (GC area)		1. Specifications are subject to change without notice. Weight and dimensions are approximate.	
Power supply	AC 110 V/127 V/220 V/230-240V, 50/60 Hz	2. Total harmonic distortion is measured by the digital spectrum analyzer.	
Power consumption	155 W		

⚠ WARNING

This service information is designed for experienced repair technicians only and is not designed for use by the general public. It does not contain warnings or cautions to advise non-technical individuals of potential dangers in attempting to service a product. Products powered by electricity should be serviced or repaired only by experienced professional technicians. Any attempt to service or repair the product or products dealt with in this service information by anyone else could result in serious injury or death.

CONTENTS

Page	Page		
1 Before Repair and Adjustment	3	10 CD Test Mode Function	17
2 Protection Circuitry	3	11 Measurements and Adjustments	17
3 Accessories	3	12 Illustration of IC's, Transistors and Diodes	21
4 Handling Precautions For Traverse Deck	4	13 Terminal Function of ICs	22
5 Precaution of Laser Diode	4	14 Block Diagram	25
6 Operation Procedures	6	15 Schematic Diagram	33
7 Operation Checks and Main Component Replacement Procedures	8	16 Printed Circuit Board	60
8 Self-Diagnostic Function	15	17 Wiring Connection Diagram	73
9 Description of Error Code	16	18 Troubleshooting Guide	74
		19 Parts Location and Replacement Parts List	75

1 Before Repair and Adjustment

Disconnect AC power, discharge Power Supply Capacitors C536, C545, C546, C548 and C555 through a 10 Ω , 5W resistor to ground.

DO NOT SHORT-CIRCUIT DIRECTLY (with a screwdriver blade, for instance), as this may destroy solid state devices.

After repairs are completed, restore power gradually using a variac, to avoid overcurrent.

For GC

Current consumption at AC 110 V, 240 V, 50 Hz in NO SIGNAL mode should be ~620mA ,~300mA respectively.

For GN

Current consumption at AC 240 V, 50 Hz in NO SIGNAL mode should be ~200mA.

2 Protection Circuitry

The protection circuitry may have operated if either of the following conditions are noticed:

- No sound is heard when the power is turned on.
- Sound stops during a performance.

The function of this circuitry is to prevent circuitry damage if, for example, the positive and negative speaker connection wires are "shorted", or if speaker systems with an impedance less than the indicated rated impedance of the amplifier are used.

If this occurs, follow the procedure outlines below:

1. Turn off the power.
2. Determine the cause of the problem and correct it.
3. Turn on the power once again after one minute.

Note:

When the protection circuitry functions, the unit will not operate unless the power is first turned off and then on again.

3 Accessories



Remote Control Transmitter

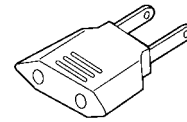

Power plug adapter (GC)



FM indoor antenna

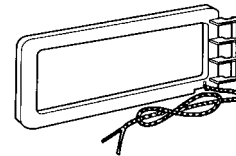

AM Loop antenna

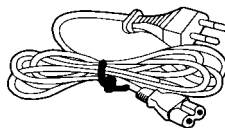

AC mains lead (GC)

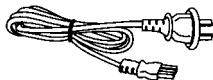

AC mains lead (GN)

4 Handling Precautions For Traverse Deck

The laser diode in the traverse deck (optical pickup) may break down due to potential difference caused by static electricity of clothes or human body.

So, be careful of electrostatic breakdown during repair of the traverse deck (optical pickup).

● Handling of traverse deck (optical pickup)

1. Do not subject the traverse deck (optical pickup) to static electricity as it is extremely sensitive to electrical shock.
2. The short land between the No.4 (LD) and No.5 (GND) pins on the flexible board (FFC) is shorted with a solder build-up to prevent damage to the laser diode.
To connect to the PC board, be sure to open by removing the solder build-up, and finish the work quickly.
3. Take care not to apply excessive stress to the flexible board (FFC board).
4. Do not turn the variable resistor (laser power adjustment). It has already been adjusted.

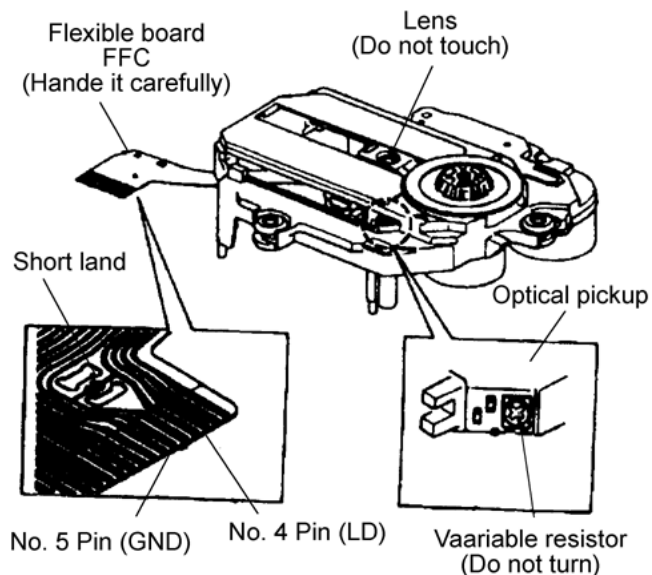

● Grounding for electrostatic breakdown prevention

1. Human body grounding

Use the anti-static wrist strap to discharge the static electricity from your body.

2. Work table grounding

Put a conductive material (sheet) or steel sheet on the area where the traverse deck (optical pickup) is placed, and ground the sheet.

Caution :

The static electricity of your clothes will not be grounded through the wrist strap. So, take care not to let your clothes touch the traverse deck (optical pickup).

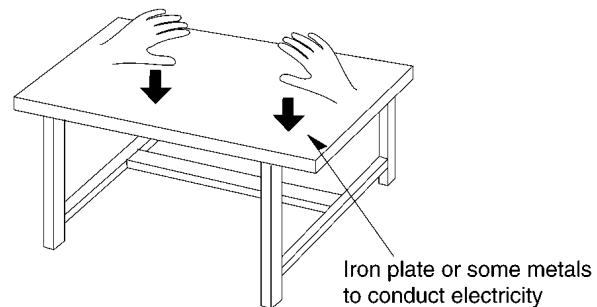
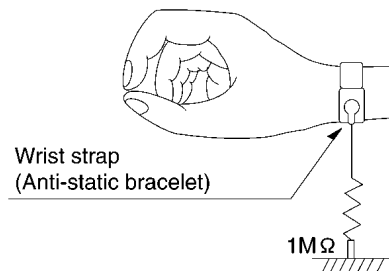

Caution when Replacing the Traverse Deck :

The traverse deck has a short point shorted with solder to protect the laser diode against electrostatics breakdown. Be sure to remove the solder from the short point before making connections.

5 Precaution of Laser Diode

Caution :

This product utilizes a laser diode with the unit turned "ON", invisible laser radiation is emitted from the pick up lens.

Wavelength : 780 nm

Maximum output radiation power from pick up : 100 μW/VDE

Laser radiation from pick up unit is safety level, but be sure the followings:

1. Do not disassemble the optical pick up unit, since radiation from exposed laser diode is dangerous.
2. Do not adjust the variable resistor on the pick up unit. It was already adjusted.
3. Do not look at the focus lens using optical instruments.
4. Recommend not to look at pick up lens for a long time.

ACHTUNG :

Dieses Produkt enthält eine Laserdiode. Im eingeschalteten Zustand wird unsichtbare Laserstrahlung von der Lasereinheit abgestrahlt.

Wellenlänge : 780nm

Maximale Strahlungsleistung der Lasereinheit :100W/VDE

Die Strahlung an der Lasereinheit ist ungefährlich, wenn folgende Punkte beachtet werden:

1. Die Lasereinheit nicht zerlegen, da die Strahlung an der freigelegten Laserdiode gefährlich ist.
2. Den werkseitig justierten Einstellregler der Lasereinheit nicht verstellen.
3. Nicht mit optischen Instrumenten in die Fokussierlinse blicken.
4. Nicht über längere Zeit in die Fokussierlinse blicken.

ADVARSEL: I dette a apparat anvendes laser.

CAUTION!

THIS PRODUCT UTILIZES A LASER.

USE OF CONTROLS OR ADJUSTMENTS OR PERFORMANCE OF PROCEDURES OTHER THAN THOSE SPECIFIED HEREIN MAY RESULT IN HAZARDOUS RADIATION EXPOSURE.

■ Use of Caution Labels



LUOKAN 1 LASERLAITE
KLASS 1 LASER APPARAT

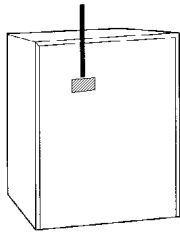

DANGER	INVISIBLE LASER RADIATION WHEN OPEN. AVOID DIRECT EXPOSURE TO BEAM.
ADVARSEL	USYNLIG LASERSTRÅLING VED ÅBNING. UNNGÅ DIREKTE UDSÆTTELSE FOR STRÅLING.
VARO!	AVATTAESSA JA SIVOLUKUTUS OHTETTAESSA OLET ALTIINA NÄKYMATÖNTÄ LASERSÄTELYLLE. ÄLÄ KATSO SÄTEESEEN.
VARNING	OSYNLIG LASERSTRÅLING NÄR DENNA DEL ÄR ÖPPNAD OCH SPÄRREN ÄR URKOPPLAD. BETRÄKTA EJ STRÅLEN.
ADVARSEL	USYNLIG LASERSTRÅLING NÄR DEKSEL ÅPNES OG SIKKERHEDSGLAS BRITES. UNNGÅ EKSPONERING FOR STRÅLEN.
VORSICHT	UNSIHTBARE LASERSTRÄHLUNG, WENN ABDECKUNG GEÖFFNET. NICHT DEM STRÄHL AUSSETZEN.

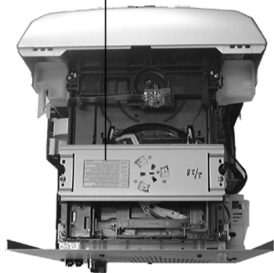

6 Operation Procedures

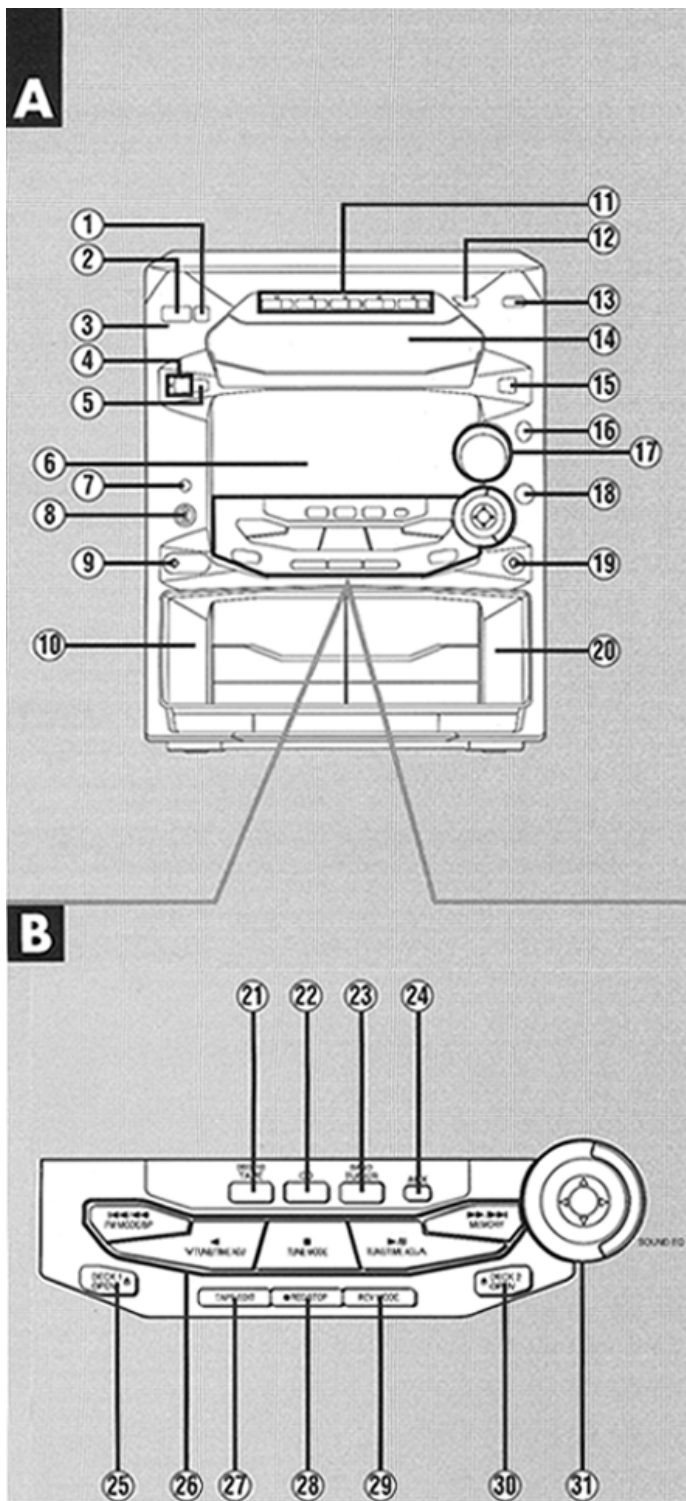

Front panel controls

Main unit **A**

No.	Name
①	Eco button (MODE)
②	Standby/on switch (⏻/⏻, POWER) Press to switch the unit from on to standby mode or vice versa. In standby mode, the unit is still consuming a small amount of power.
③	AC supply indicator (AC IN) This indicator lights when the unit is connected to the AC main supply.
④	Play timer/record timer button and indicator (⌚PLAY/⌚REC)
⑤	Clock/timer button (CLOCK/TIMER)
⑥	Display
⑦	Karaoke button (KARAOKE)
⑧	Microphone volume control (MIC VOL)
⑨	Microphone jack (MIXING MIC)
⑩	Deck 1 cassette holder
⑪	Disc direct play, open/close buttons and indicators (CD 1 ~ CD 5, ⬆)
⑫	CD manager button (CD MANAGER)
⑬	Random play button (RANDOM)
⑭	Disc tray
⑮	Display select/demonstration button (-DISP/-DEMO)
⑯	V.BASS on/off button (V.BASS)
⑰	Volume control (VOLUME)
⑱	3D AI EQ button (3D AI EQ)
⑲	Headphone jack (PHONES)
⑳	Deck 2 cassette holder

Center console **B**

㉑	Tape/deck select button (TAPE, DECK 1/2)
㉒	CD button (CD)
㉓	Tuner/band select button (TUNER, BAND)
㉔	AUX button (AUX)
㉕	Deck 1 open button (⬆ DECK 1 OPEN)
㉖	Basic operating buttons Functions change according to the source.
㉗	Tape edit button (TAPE EDIT)
㉘	Recording start/stop button (● REC/STOP)
㉙	Reverse mode select button (REV MODE)
㉚	Deck 2 open button (⬆ DECK 2 OPEN)
㉛	Sound equalizer control (SOUND EQ)

Front panel controls

Remote control

Buttons such as ② functions in exactly the same way as the buttons on the main unit.

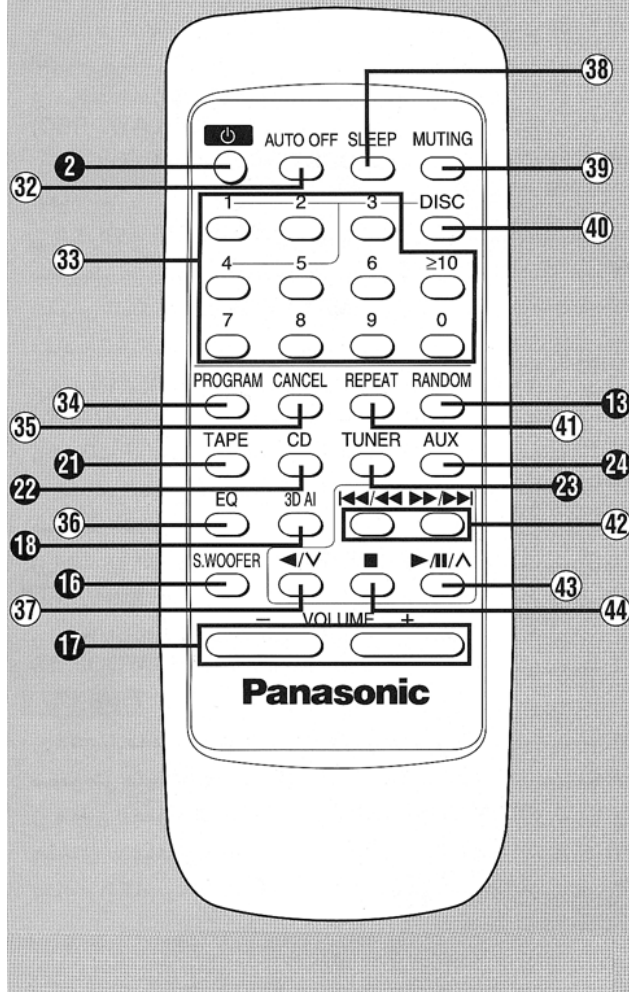

No.	Name
②	Standby/on button (⏻)
③②	Auto off button (AUTO OFF)
③③	Numeric buttons (≥10, 1-0)
③④	Program button (PROGRAM)
③⑤	Cancel button (CANCEL)
②①	Tape/deck select button (TAPE)
②②	CD button (CD)
③⑥	EQ select button (EQ)
③⑦	3D AI EQ button (3D AI)
④①	V.BASS on/off button (V.BASS)
④②	Reverse side playback/preset channel select button (◀/V)
④③	Volume buttons (- VOLUME +)
④④	Sleep button (SLEEP)
④⑤	Muting button (MUTING)
④⑥	Disc button (DISC)
④⑦	Random button (RANDOM)
④⑧	Repeat button (REPEAT)
④⑨	AUX button (AUX)
⑤①	Tuner/band select button (TUNER)
⑤②	Skip/search buttons (◀◀/◀, ▶▶/▶)
⑤③	Play/pause/preset channel select button (▶/ /△)
⑤④	Stop button (■)

7 Operation Checks and Main Component Replacement Procedures

“ATTENTION SERVICER”

Some chassis components may have sharp edges.

Be careful when disassembling and servicing.

1. This section describes procedures for checking the operation of the major printed circuit boards and replacing the main components.
2. For reassembly after operation checks or replacement, reverse the respective procedures. Special reassembly procedures are described only when required.
3. Select items from the following index when checks or replacement are required.

Contents

- **Checking Procedure for each major P.C.B.**
 1. Checking of the Main, Panel, Deck and Power P.C.B.
- **Main Component Replacement Procedures**
 1. Replacement of the Traverse Deck.
 2. Replacement of the Power Amplifier IC.
- **Disassembly and assembly of the Traverse Unit**
- **Disassembly and assembly of the Disc Tray**

Warning:

This product uses a laser diode. Refer to caution statement “Precaution of Laser Diode.

ACHTUNG:

- Die Lasereinheit nicht zerlegen.
- Die Lasereinheit darf nur gegen eine vom Hersteller spezifizierte Einheit ausgetauscht werden.

7.1. Checking Procedure for each major P.C.B.

7.1.1. Checking of the Main, Panel, Deck and Power P.C.B.

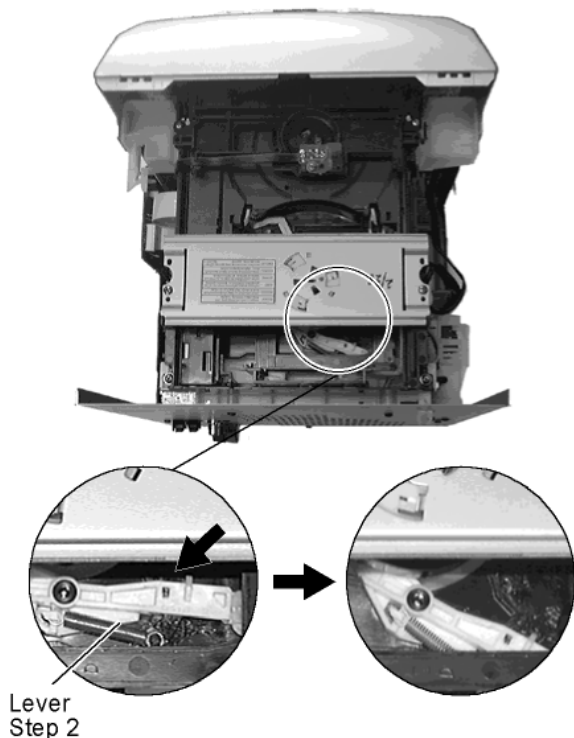

Step 1 Remove the Top Cabinet.

Step 2 Push the lever in the direction of the arrow.

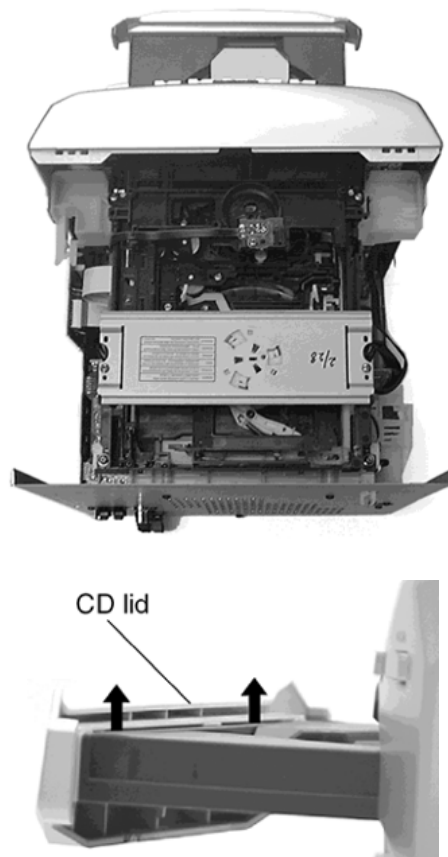

Step 3 Pull out the CD tray as shown and remove the CD lid. Push back the CD tray after the CD lid has been removed.

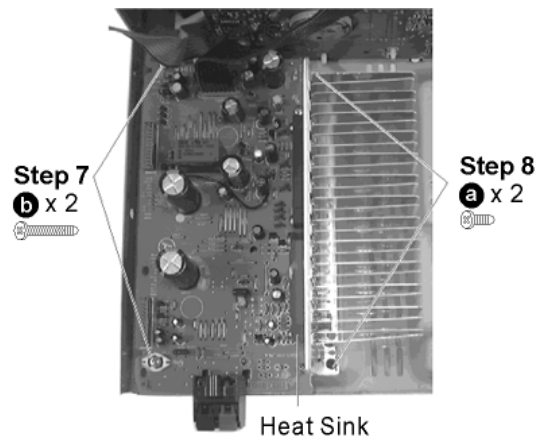
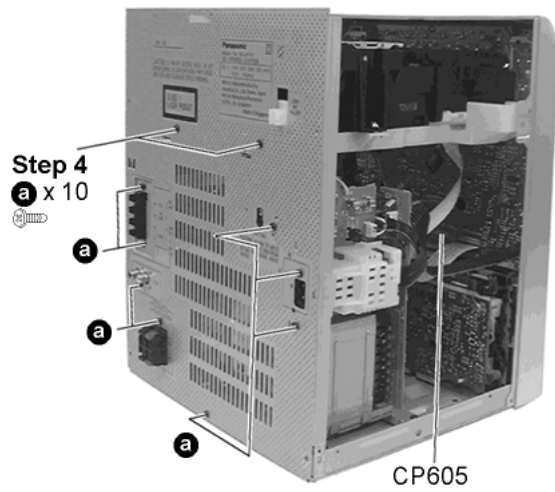

Step 5 Remove the wire at CP605 and CN309.

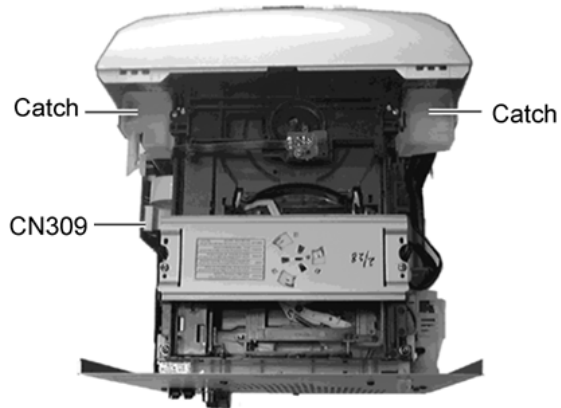

Step 6 Release the 2 catches and remove the CD changer base together with the CD changer.

• **Checking for Power P.C.B.**

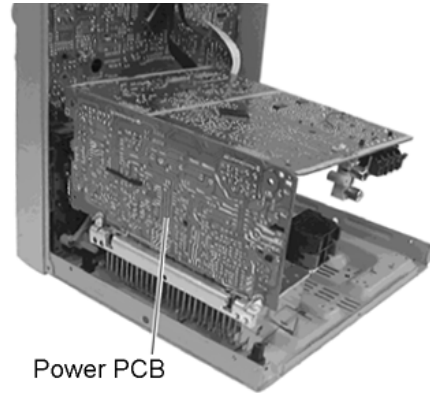

• **Checking for Main, Panel and Deck P.C.B**

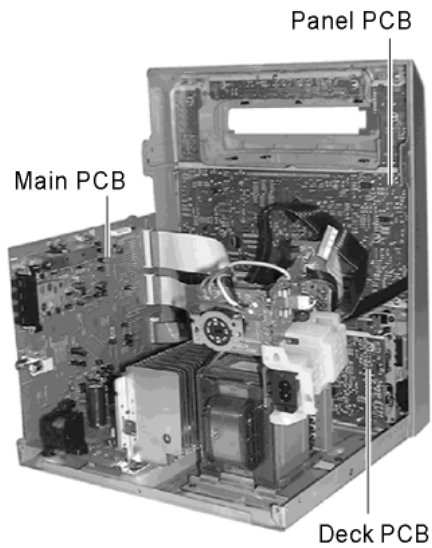

7.2. Main Component Replacement Procedures

7.2.1. Replacement of the Traverse Deck

Step 1 Follow the procedures in 'Disassembly of the Traverse Unit' (**Step 1 - Step 4**).

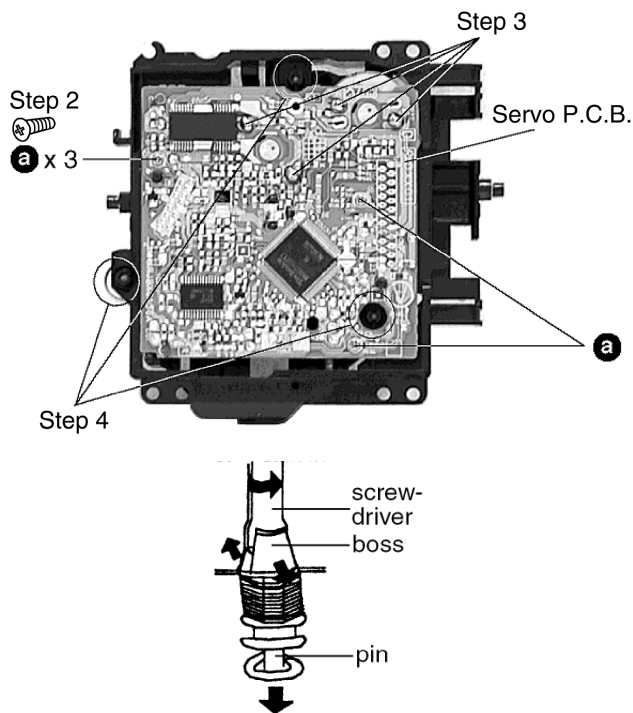

Step 3 Desolder the 4 legs of the 2 motors and pull out the Servo P.C.B.

Step 4 Widen the 3 bosses with a flat screwdriver and pull out the 3 pins. Then remove the Traverse Deck.

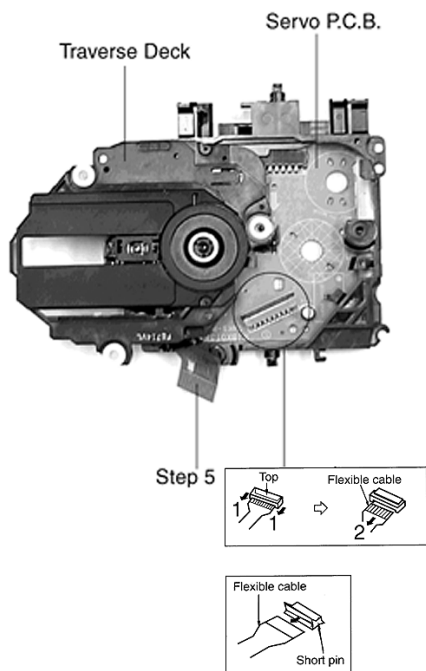

Step 5 Remove the flexible cable CN701.

- Removal of the flexible cable. Push the top of the connector in the direction of the arrow 1, and then pull out the flexible cable in the direction of the arrow 2.

Note:

Insert a short pin into the flexible cable for traverse unit.

- **Installation of the CD servo P.C.B. after replacement**

Step 1 Connect the FFC board.

Step 2 Install the CD servo P.C.B. in the traverse deck assembly.

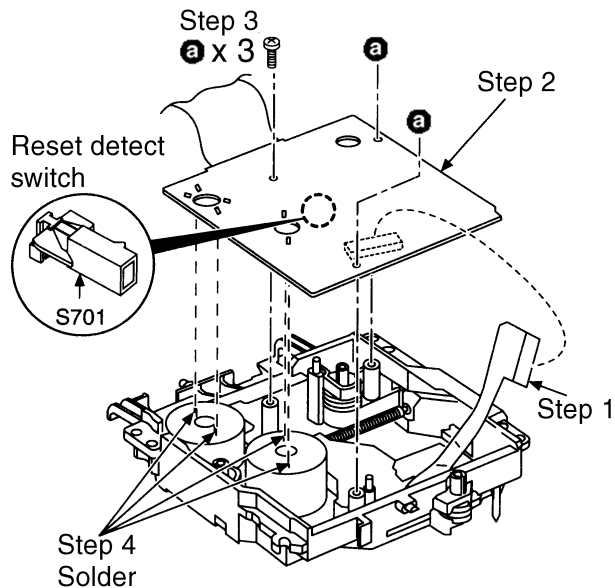

Note:

Before installing the CD servo P.C.B., move the optical pickup towards the outer edge from the marking (black triangle).

[Otherwise, the reset detect switch (S701) mounted on the CD servo P.C.B. may be damaged.]

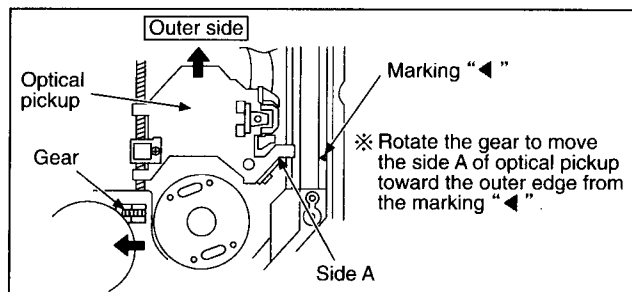

7.2.2. Replacement of the Power Amplifier IC

Step 1 Follow the procedures in 'Checking Procedure for each major P.C.B.' (**Step 1 - Step 6**).

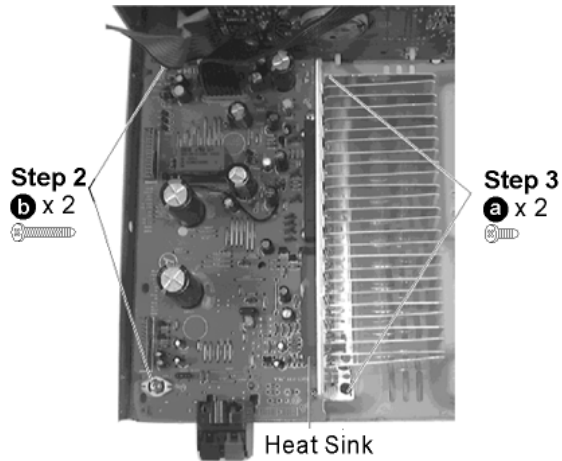

Step 6 Unsolder the terminals of Power Amp IC and replace the respective component.

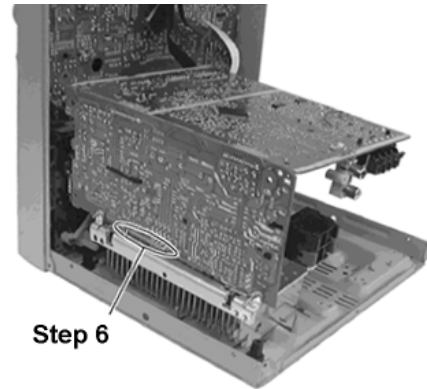

Step 4 Remove the wires at CN302, CN303 and CN304 and pull out the Main PCB.

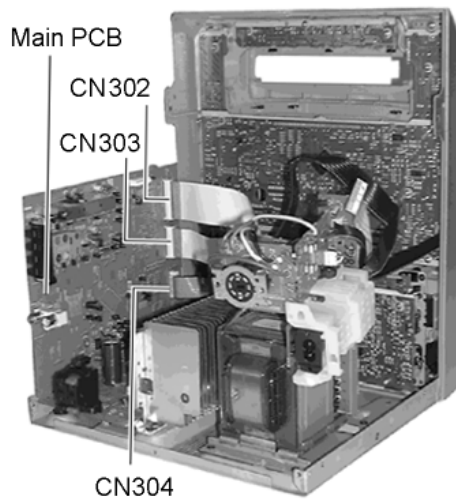

Step 5 Remove the 4 screws fixed to the Power Amplifier IC.

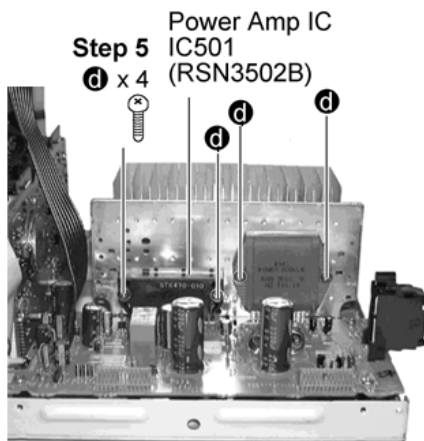

7.3. Disassembly and assembly of the Traverse Unit

Step 1 Push the lever from position A to B.

Step 2 Pull the stopper (black) in the direction of arrow 1 and push the lever in the direction of arrow 2.

Step 3 Push the stopper (black) down until the white lever eject out.

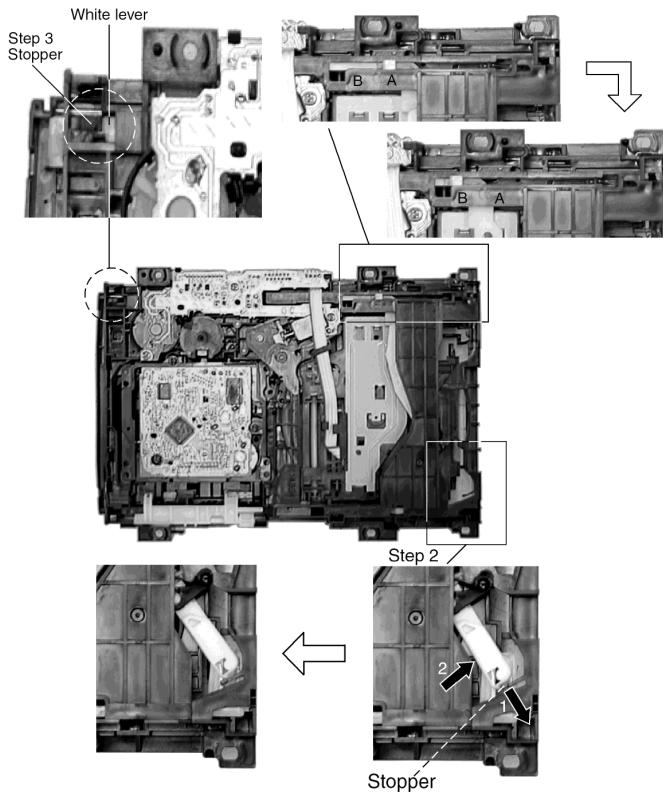

Step 4 Lift up the traverse unit and slide out the unit as shown.

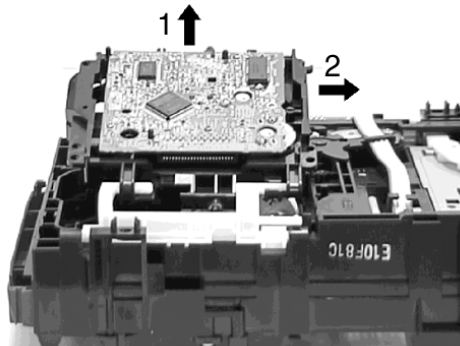

• Replacement of Traverse Unit

Step 1 Place the traverse unit as shown.

Step 2 Press in the lever shaft in the direction of arrow 1 as shown and push the traverse unit into the position in the direction of arrow 2.

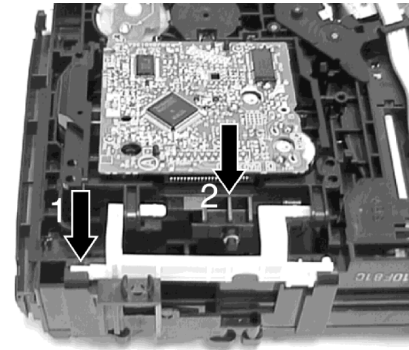

Step 3 Pull the stopper in the direction of arrow 1 and release the lever in the direction of arrow 2 as shown.

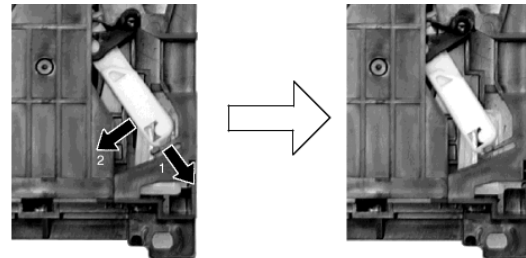

Step 4 Pull out the tray half way and push it back fully.

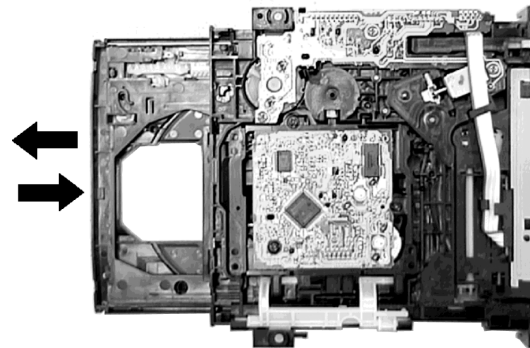

Step 5 Push the lever to the initial position indicated '|---|'.

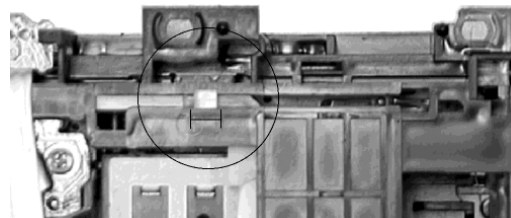

7.4. Disassembly and assembly of the Disc Tray

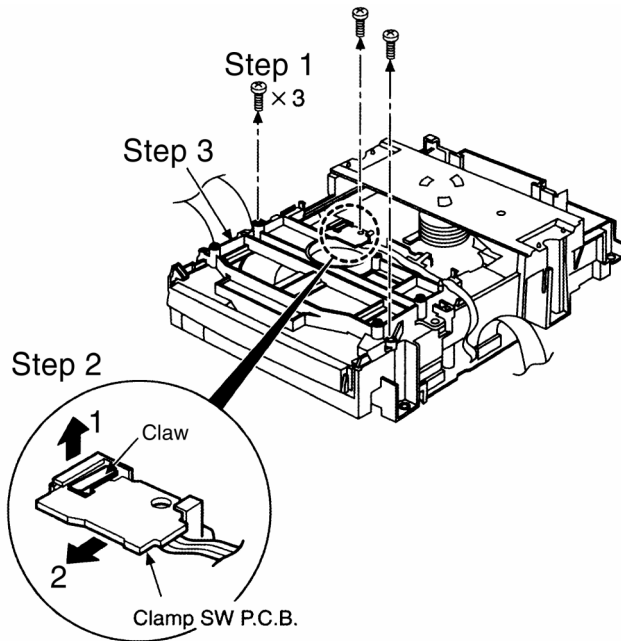

Step 2 With lifting the claw in the direction of arrow 1, draw the clamp SW P.C.B. in the direction of arrow 2.

Step 3 Remove the mechanism cover.

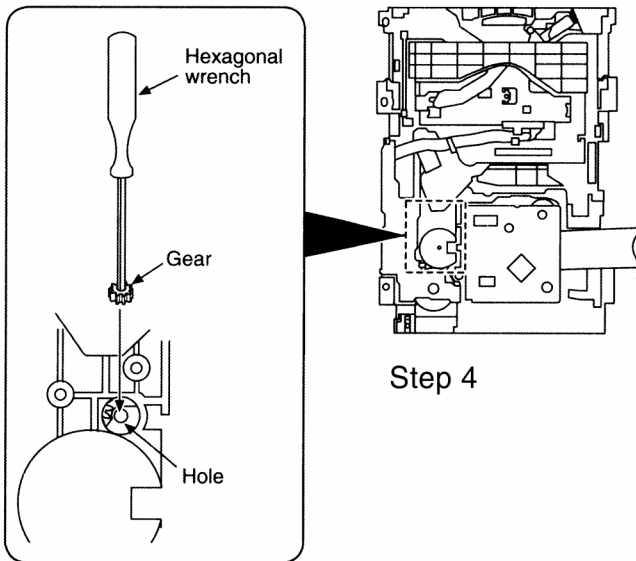

Step 4 Insert the gear with hexagonal wrench into the hole.

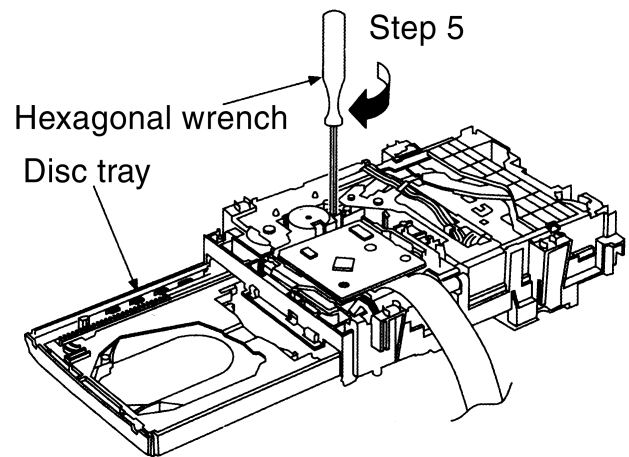

Step 5 Rotate the hexagonal wrench in the direction of arrow (clockwise), and then open the disc tray fully.

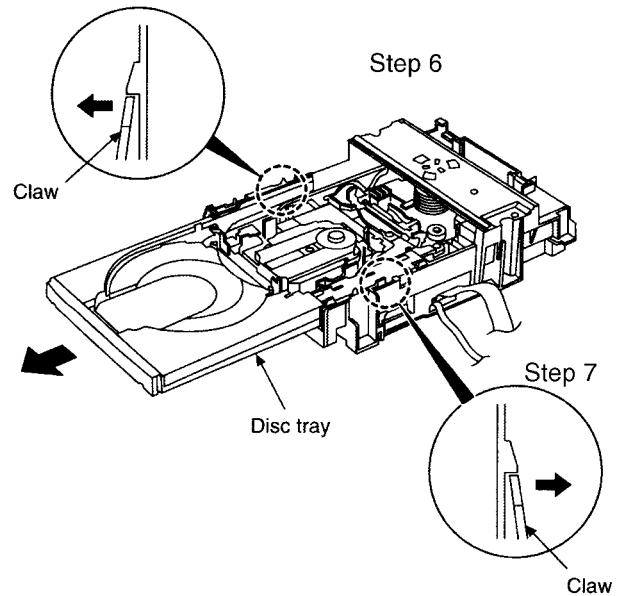

Step 6 Upset the CD changer unit again.

Step 7 Release both the claws, and then draw the disc tray.

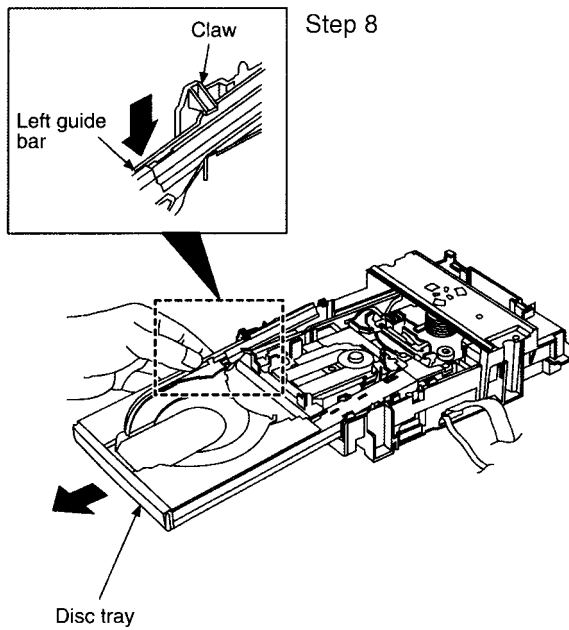

Step 8 With forcing the left guide bar manually because the left guide bar interferes with claw, draw the disc tray.

• **Installation of the disc tray after replacement**

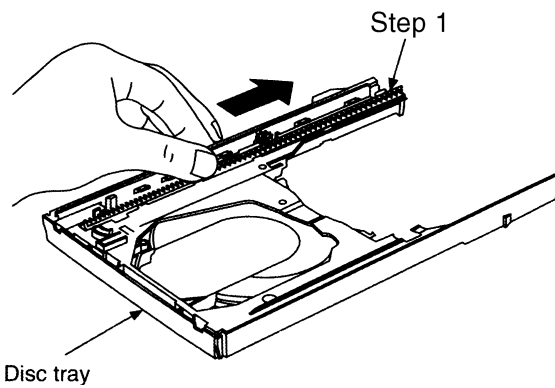

Step 1 Slide the drive rack fully in the direction of the arrow.

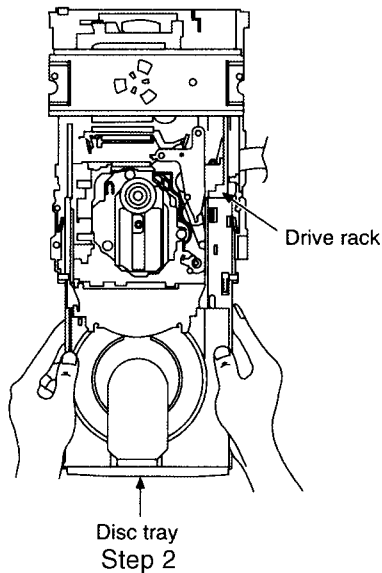

Step 2 Holding the drive rack, not to move, install the disc tray.

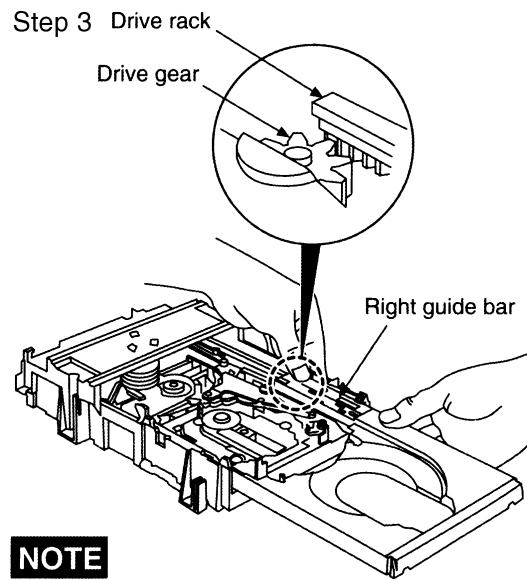

NOTE

Force the right guide bar of tray base manually not to move upwards.

Step 3 Align the drive rack with the drive gear.

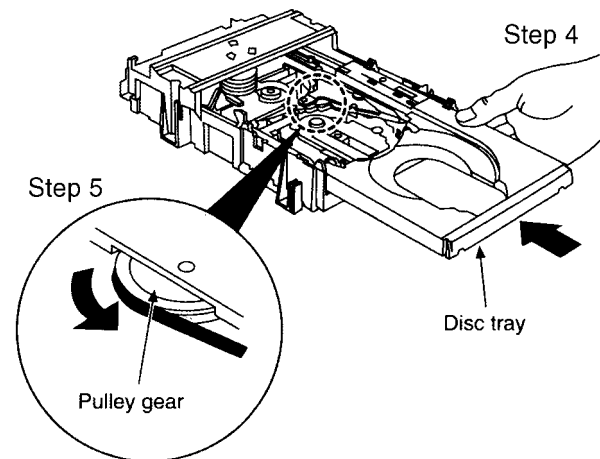

Step 4 Holding the disc tray manually, rotate the pulley gear in the direction of arrow.

Step 5 Rotate the gear 5 or 6 times manually, and then push the disc tray.

8 Self-Diagnostic Function

8.1. Self-diagnostic display

This unit is equipped with a self-diagnostic display function which, if a problem occurs, will display an error code corresponding to the problem.

Use this function when performing maintenance on the unit.

8.2. How to enter the Self-Diagnostic Function

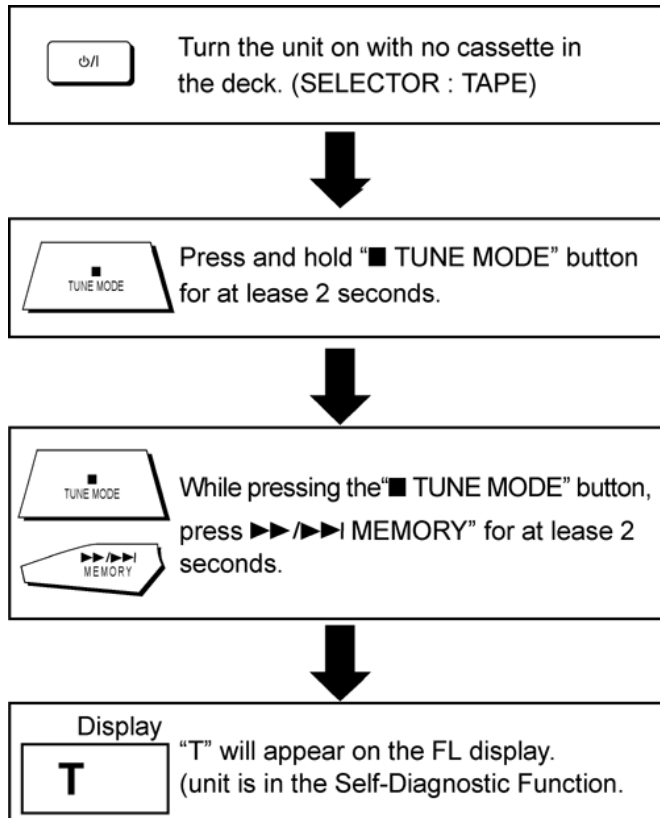

8.3. Cassette Mechanism Test (For error code H01, H02, H03, F01, F02)

1. Press "TAPE, DECK 1/2" to select Deck 2.
2. Load a cassette tape with the erasure prevention tab, remove from left side only and close the cassette holder.
3. Press "FAST FORWARD MEMORY" (Tape will be stop after 2 seconds)
4. Load a cassette tape with the erasure prevention tab, remove from right side only and close the cassette holder.
5. Press "REVERSE FM MODE/BP" (Tape will be stop after 2 seconds)
6. Load a pre-recorded tape with both side record tabs intact and close the cassette holder.
7. Press "PLAY/TUNE/TIME ADJ UP" (After TPS function, tape will stop automatically)
8. Press "REC/STOP" (Tape will not move)
9. Press "STOP/TUNE MODE" to indicate Error code.
 - If several problem exist, error code will change each time when "■ /TUNE MODE" is pressed. (e.g. H01 → H03 → F01etc.)
10. Press "TAPE, DECK 1/2" to select Deck 1.
11. Repeat step 2 to 9 to test Deck 1. (Tape Deck 1 will not check H02 because of no recording function)

8.4. CD Mechanism Test (F15, F26, F16, F17, F27, F28, F29, H15, F75)

1. Press "CD".
2. Press "OPEN/CLOSE (1)" and place a CD.
3. Press "OPEN/CLOSE (1)" to close the tray.

4. Press "OPEN/CLOSE (5)" and wait until the tray is open.

5. Press "OPEN/CLOSE (1)" and remove the CD.

6. Press "OPEN/CLOSE (1)" to close the tray.

7. Press "■/TUNE MODE" to indicate Error Code.

- If several problem exist, error code will change each time when "■/TUNE MODE" is pressed. (e.g. F15 → F26 → F16etc).

8.5. To clear all Error code

1. Press "STOP/TUNE MODE" button for 5 seconds.

2. FL indicator shows "CLEAR" for 1 second and change to "T".

8.6. How to get out from Self-Diagnostic function

1. Press "Power" button OFF.

8.7. Power Amplifier Failure (F61)

1. When power amplifier fail, F61 will indicate automatically.

9 Description of Error Code

9.1. Error detection for Cassette Mechanism block

No.	Error	Error Display	Problem condition
1	MODE SW detection error	H01	Faulty operation of cassette mechanism. Faulty contact or short-circuit of mechanism mode switch (S951, S971).
2	REC INH SW detection error	H02	Recording not possible. Faulty contact or short-circuit of REC INH switch (S974, S975).
3	HALF SW detection error	H03	Playback cannot perform. Faulty contact or short-circuit of HALF switch (S952, S972).
4	Reel Pulse detection error	F01	The tape advances slightly and then stops. Faulty reel pulse, faulty hole detect IC (IC951, IC971).
5	TPS abnormal	F02	Cassette deck will not perform TPS function. Faulty playback EQ/recording amplifier IC (IC101).

9.2. Error detection for CD/Changer block

No.	Error	Error Display	Problem condition
1	REST SW detection error	F15	CD does not function. This error occurs when the Optical Pick Up REST SW (S701) is not detected within the specified time (about 8 seconds)
2	CD tray opens automatically	F16	CLAMP switch (S4) NG (Check & Replace)
3	Does not startup when [PLAY] button is pressed	F17	BOTTOM switch (S5) NG (Check & Replace)
4	Transmission error between CD servo LSI and micon	F26	CD does not function. This error occurs when the POWER is ON for the CD block and an error is detected after the transmission has started.
5	Startup fails even when you insert CD or the selected disc tray does not open	F27	Tray 1 detect switch or Tray 2 detect switch NG (Check & Replace)
6	Cannot insert CD	F28	Tray 1 detect switch NG (Check & Replace)
7	Cannot eject CD	F29	Check if disc is stuck. Tray 2 detect switch NG (Confirm & Replace)
8	The CD tray closes	H15	CD disc tray detect switch NG (S3) (Check & Replace)

9.3. Power Supply related error detection

No.	Error	Error Display	Problem condition
1	POWER AMP output abnormal	F61	When POWER is switched on, power become off automatically. During normal operation, if DC DET become L, PCNT shall become L and the error display on the left shall be displayed. (IC501)

10 CD Test Mode Function

This CD test mode is provided to check CD unit without connecting to changer loading mechanism. This mode shall operate CD PLAY with CD unit being connected only and CD Automatic Alignment result is shown on FL display.

10.1. How to set CD test mode

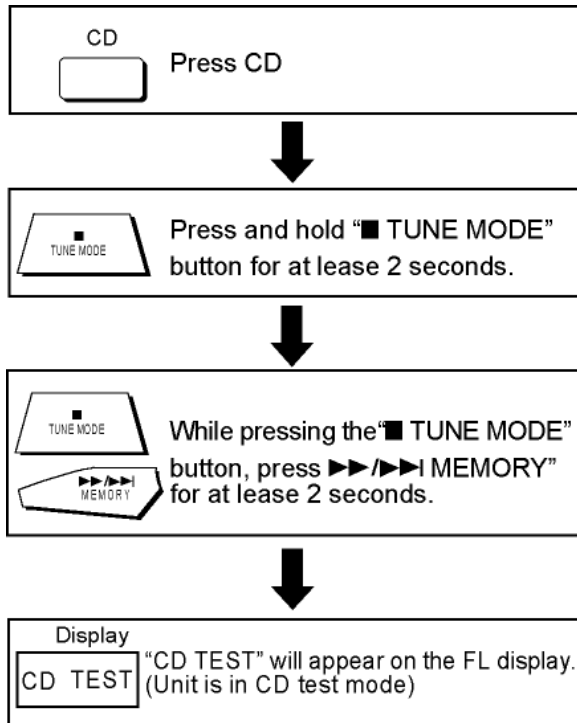

10.2. CD Automatically Adjustment result indication

Under CD test mode, pressing the numeric key '0' on the remote controller will display the auto adjustment result. FLOCK, TLOCK and CLVS status shall be shown as below:

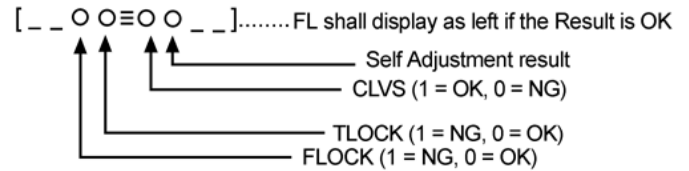

During the above display, executing CD PLAY will display auto adjustment result for CD PLAY mode.

11 Measurements and Adjustments

11.1. Cassette Deck Section

- Measurement Condition
 - Reverse-mode selector switch:
 - Tape edit: NORMAL
 - Record timer: OFF
 - Make sure head, capstan and press roller are clean.
 - Judgeable room temperature $20 \pm 5 \text{ }^\circ\text{C}$ ($68 \pm 9^\circ\text{F}$)
- Measuring instrument
 - EVM (Electronic Voltmeter)
 - Digital quency counter
- Test Tape
 - Head azimuth adjustment (8 kHz, -20 dB); QZZCFM
 - Tape speed gain adjustment (3 kHz, -10 dB); QZZCWAT
 - Playback gain adjustment (315 Hz, 0 dB); QZZCFM
 - CrO2 tape, QZZCRX

11.1.1. Head Azimuth Adjustment (Deck 1/2)

Caution:

- Please replace both azimuth adjustment screw (RHE5152ZB) and springs (RM0331) simultaneously when readjusting the head azimuth. (shown in Fig. 2) Even if you

wish to readjust the head azimuth without replacing the acrews and springs, a fine adjustment to the azimuth screw and spring.

- Please remove the screw-locking bond left on the head base when replacing the azimuth screw.
 - If you wish to readjust the head azimuth, be sure to adjust with adhering the cassette tape closely to the mechanism by pushing the center of cassette tape with your finger. (shown in Fig. 3)
1. Playback the azimuth adjustment portion (8 kHz, -20dB) of the test tape (QZZCFM) in the forward play mode. Vary the azimuth adjustment screw until the output of the R-CH (PB OUT-R) are maximized.
 2. Perform the same adjustment in the reverse play mode.
 3. After the adjustment, apply screwlock to the azimuth adjusting screw.

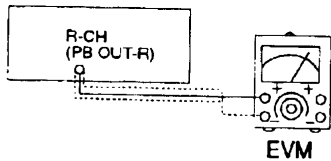

Fig. 1

- (RHE5152ZB)
- (RMB0331)

Fig.2

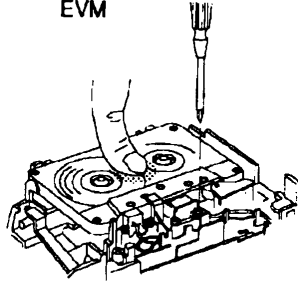

Fig. 3

E. HEAD R/P HEAD

Azimuth Screw (Forward) Azimuth Screw (Reverse)

Fig. 4

11.1.2. Tape Speed Adjustment (Deck 1/2)

1. Set the tape edit button to "NORMAL" position.
2. Insert the test tape (QZZCWAT) to DECK 2 and playback (FWD side) the middle portion of it.
3. Adjust Motor VR (DECK 2) for the output value shown below.

Adjustment target: 2940 ~ 3060 Hz (NORMAL speed)

4. After alignment, assure that the output frequency of the DECK 2 REV and DECK 1 FWD are within $\pm 45\text{Hz}$ and $\pm 60\text{Hz}$ respectively of the value of the output frequency of DECK 2 FWD.

UNIT

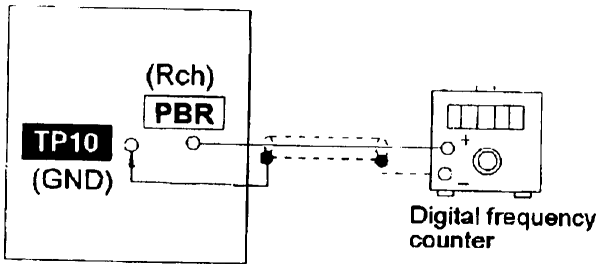

11.1.3. Bias and Erase Voltage Check

1. Set the unit "AUX" position.
2. Insert the Normal blank tape (QZZCRA) into DECK 2 and the unit to "REC" mode (use "● REC/STOP" key).
3. Measure and make sure that the output is within the standard value.
4. Insert the CrO2 tape (QZZCRX).
5. Repeat step 2 and 3.

Bias voltage for Deck 2	$14 \pm 4\text{mV}$ (Normal)
Standard value)	$17 \pm 5\text{mV}$ (CrO2)
Erase voltage for Deck 2	more than 80mV (Normal)
	more than 90mV (CrO2)

Bias

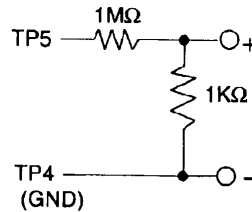

Erase

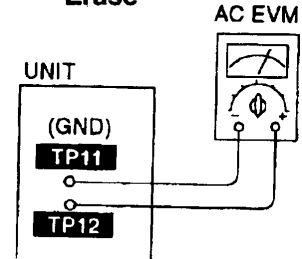

11.1.4. Bias Frequency Adjustment (Deck 1/2)

1. Set the unit to "AUX" position.
2. Insert the Normal blank tape (QZZCRA) into DECK 2 and set the unit to "REC" mode (● use "REC/STOP" key).
3. Adjust L1002 so that the output frequency is within the standard value.

Standard Value: $97 \pm 8\text{kHz}$

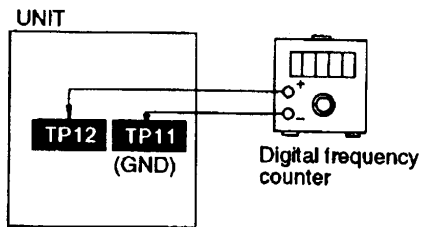

11.2. Tuner Section

11.2.1. AM-IF Alignment

SIGNAL GENERATOR OR SWEEP GENERATOR		RADIO DIAL SETTING	INDICATOR (ELECTRONIC VOLTMETER OSCILLOSCOPE)	ADJUSTMENT (Shown in Fig.3)	REMARKS
CONNECTIONS	FREQUENCY				
Fashion a loop of several turns of wire and radiate a signal into the loop ant. of receiver.	450 kHz 30% Mod. at 400Hz.	Point of non-interference (on/about 600 kHz)	Headphones Jack (32Ω) Fabricate the plug as shown in Fig. 2 and then connect the lead wires of the plug to the measuring instrument.	Z102 (AM IFT)	Adjust for maximum output.

11.2.2. AM-RF Alignment

SIGNAL GENERATOR OR SWEEP GENERATOR		RADIO DIAL SETTING	INDICATOR (ELECTRONIC VOLTMETER OSCILLOSCOPE)	ADJUSTMENT (Shown in Fig.3)	REMARKS
CONNECTIONS	FREQUENCY				
Fashion a loop of several turns of wire and radiate a signal into the loop ant. of receiver.	522 kHz	Tuning capacitor fully closed	Headphones Jack (32Ω) Fabricate the plug as shown in Fig. 2 and then connect the lead wires of the plug to the measuring instrument.	Z152 (GC), Z101(GN) (AM OSC Coil)	Adjust for maximum output.
Fashion a loop of several turns of wire and radiate a signal into the loop ant. of receiver.	603 kHz	Tuning to signal	Headphones Jack (32Ω) Fabricate the plug as shown in Fig. 2 and then connect the lead wires of the plug to the measuring instrument.	Z152 (GC), Z101(GN) (AM ANT Coil)	Adjust for maximum output.

11.2.3. SW1-RF Alignment (GC)

SIGNAL GENERATOR OR SWEEP GENERATOR		RADIO DIAL SETTING	INDICATOR (ELECTRONIC VOLTMETER OSCILLOSCOPE)	ADJUSTMENT (Shown in Fig.3)	REMARKS
CONNECTIONS	FREQUENCY				
Fashion a loop of several turns of wire and radiate a signal into the loop ant. of receiver.	3.2 MHz	Tuning capacitor fully closed	Headphones Jack (32Ω) Fabricate the plug as shown in Fig. 2 and then connect the lead wires of the plug to the measuring instrument.	Z152 (SW1 OSC Coil)	Adjust for maximum output.
Fashion a loop of several turns of wire and radiate a signal into the loop ant. of receiver.	3.2 MHz	Tuning to signal	Headphones Jack (32Ω) Fabricate the plug as shown in Fig. 2 and then connect the lead wires of the plug to the measuring instrument.	Z152 (SW1 ANT Coil)	Adjust for maximum output.

11.2.4. SW2-RF Alignment (GC)

SIGNAL GENERATOR OR SWEEP GENERATOR		RADIO DIAL SETTING	INDICATOR (ELECTRONIC VOLTMETER OSCILLOSCOPE)	ADJUSTMENT (Shown in Fig.3)	REMARKS
CONNECTIONS	FREQUENCY				
Fashion a loop of several turns of wire and radiate a signal into the loop ant. of receiver.	9.4 MHz	Tuning capacitor fully closed	Headphones Jack (32Ω) Fabricate the plug as shown in Fig. 2 and then connect the lead wires of the plug to the measuring instrument.	Z151 (SW2 OSC Coil)	Adjust for maximum output.
Fashion a loop of several turns of wire and radiate a signal into the loop ant. of receiver.	9.4 MHz	Tuning to signal	Headphones Jack (32Ω) Fabricate the plug as shown in Fig. 2 and then connect the lead wires of the plug to the measuring instrument.	Z151 (SW2 ANT Coil)	Adjust for maximum output.

11.3. Alignment Points

Cassette Deck section

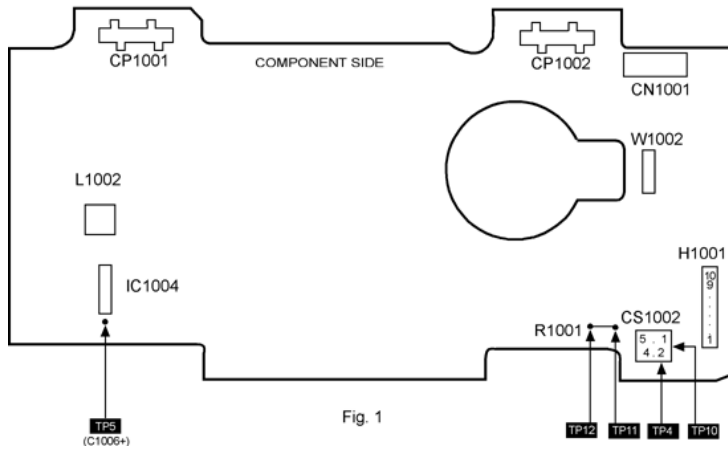

Fig. 1

Tuner section

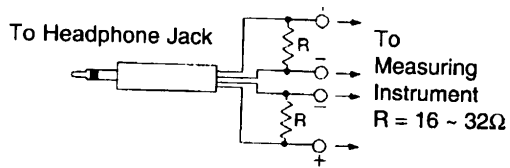

Fig. 2

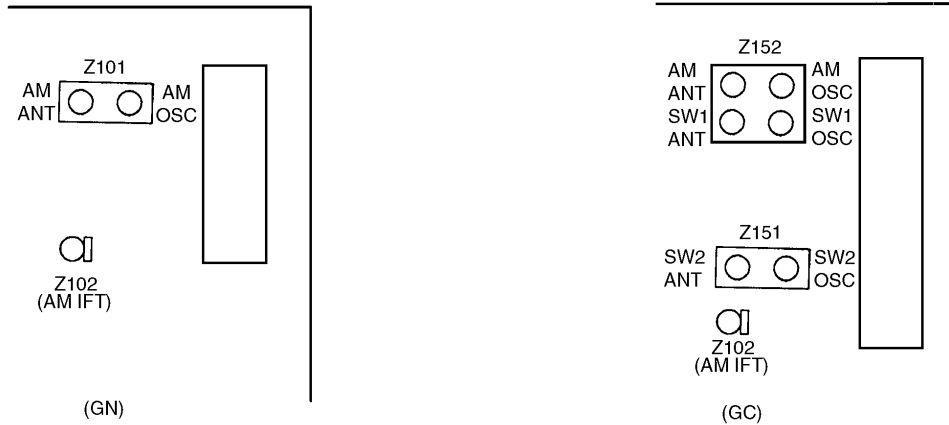
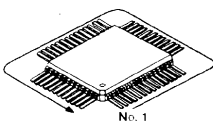
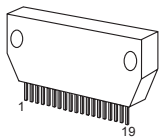
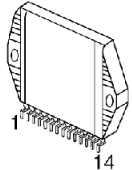
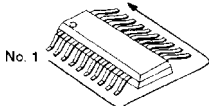
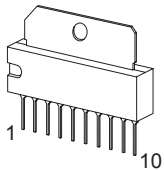
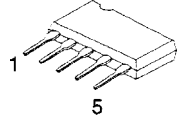
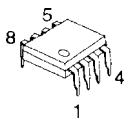
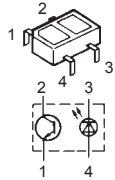
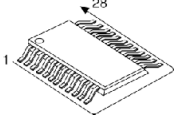
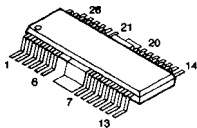
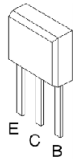
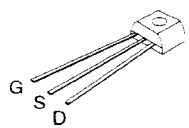
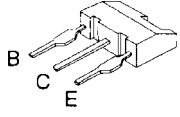
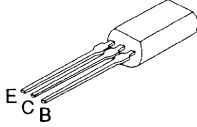
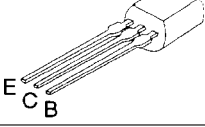
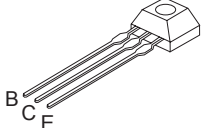
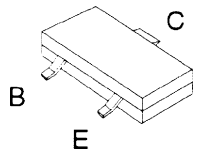
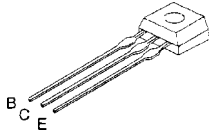
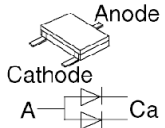
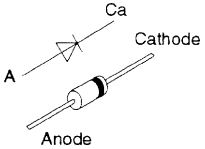
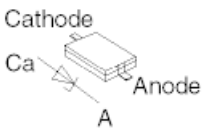
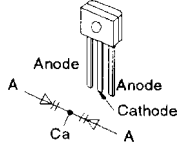
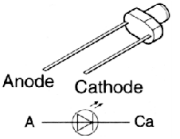
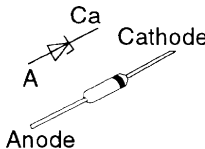
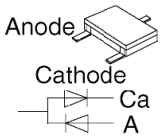
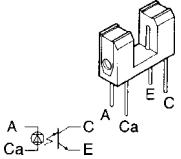
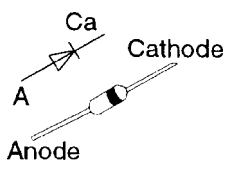

Fig.3

12 Illustration of IC's, Transistors and Diodes

M38199MF227 (100P) M62433AFP (80P) MN662790RSC (80P) 	STK470-010A 	RSN3502B 	BU2090AF-E2 (16P) LA1833NMNTLM (24P) LC72131MDTRM (20P) AN7348STA-E1 (24P) BA4558FE2 (8P) M62457AFPE1 (16P) 	TA7291P 	
BA7755A 	M5218AP 	0N2180RLC1 	AN8839NSBE2 (28P) 	AN8739SBE2 	2SA1309ARTA 2SC2058SPTA 
2SK544F-AC 	2SB1238QRTV2 	2SC3940AQSTA 	KTA12710YTA 2SD965RTA 2SB621ARSTA 	KRC110MTA KRA102MTA KRC103MTA KRC102MTA 	
2SA1037AKSTX 2SC2412KT96R DTC144TKA146 DTA114EKA146 KRA102STA DTC114EKA146 KTC3875GRtA KRC111STA KTD1304TA KRC102STA DTC143XKA146 	2SA933SSTA 2SC1740SSTA 2SC2787FL1TA 2SD2144STA KTC3199GRTA RVTDTA143EST 2SC2786MTA 2SC2784FTA RVTDTA114EST 2SC2785FTA 2SA1309ARTA 				
DAP202KT146 	1D3E RL1N4003S-P 	1SS355TE17 UDZSTE175R1B UDZTE173R6B 	SVC211SPA-AL 	SLI325URCT31 SLI325DCT31 SLR325MCT31W SLR505DCT31 	
MTZJ10BTA MTZJ4R7BTA MTZJ8R2BTA MTZJ12BTA MTZJ7R5ATA MA4020LTA MTZJ6R8BTA MTZJ33BTA MTZJ16BTA 	DA204KT146 	GP1S94 	RVD1SS133TA 1SS291TA MA165TA MA700ATA MA723TA 		

13 Terminal Function of ICs

13.1. IC701 (AN8839NSBE2) Servo Amplifier

Pin No.	Mark	I/O	Function
1	PDE	I	Tracking signal input 1
2	PDF	I	Tracking signal input 2
3	VCC	I	Power supply
4	PDA	I	Focus signal input terminal 1
5	PDB	I	Focus signal input terminal 2
6	LPD	I	APC amp input
7	LD	O	APC amp output
8	RF	O	RF summing output
9	RFIN	I	Detector's input
10	CSBRT	I	Capacitor for OFTR connection
11	CEA	I	Capacitor for HPF amp connection
12	BDO	O	BDO output ("H" : drop out)
13	LDON	I	APC control
14	GND	—	Ground

Pin No.	Mark	I/O	Function
15	/RFDET	O	NRFDET output ("L" : detection)
16	PDOWN	O	Power-down input
17	OFTR	O	OFTR output
18	NC	O	N.C.
19	ENV	O	3T-ENV output
20	NC	I	N.C.
21	NC	I	N.C.
22	TEN	I	TE amp input
23	TEOUT	O	TE amp output
24	FEOUT	O	FE amp output
25	FEN	I	FE amp input
26	VREF	O	Reference voltage output
27	TBAL	I	Tracking balance control
28	FBAL	I	Focus balance control

13.2. IC702 (MN662790RSC) Servo processor/ Digital signal processor/ Digital filter/ D/A converter

No.	Mark	I/O	Function
1	BCLK	O	N.C.
2	LRCK	O	N.C.
3	SRDATA	O	N.C.
4	DVDD1	I	Power supply input (for digital circuit)
5	DVSS1	I	GND (for digital circuit)
6	TX	O	Digital audio interface signal output (Latches data at first transition)
7	MCLK	I	Microprocessor command clock signal input
8	MDATA	I	Microprocessor command data signal input
9	MLD	I	Microprocessor command load signal input
10	SENSE	O	Sense signal output (OFT, FESL, MAGEND, NAJEND, PO SAD, SFG) (Not used, open)
11	/FLOCK	O	Focus servo feeding signal output ("L" : Feed)
12	/TLOCK	O	Tracking servo feeding signal output ("L" : Feed)
13	BLKCK	O	Sub-code block clock signal output (fBLKCK = 75Hz during normal playback)
14	SQCK	I	External clock signal input for sub-code Q resistor
15	SUBQ	O	Sub-code Q code output
16	DMUTE	I	Muting input ("H": mute)
17	STAT	O	Status signal output (CRC, CUE, CLVS, TTSTVP, F CLV, SQCK)
18	/RST	I	Reset signal input
19	SMCK	O	1/2-divided clock signal of crystal oscillating at MSEL = "H" (fSMCK = 8.4672 MHz) 1/4-divided clock signal of crystal oscillating at MSEL = "L" (fSMCK = 4.2336 MHz)
20	CSEL	I	Frequency Selection Terminal H = 33.8688 MHz; L = 16.9344 MHz
21	TRV	O	N.C.
22	TVD	O	Traverse drive output
23	PC	O	Spindle motor ON output ("L" : ON)

No.	Mark	I/O	Function
24	ECM	O	Spindle motor drive signal output(forced mode output)
25	ECS	O	Spindle motor drive signal output (servo error signal output)
26	KICK	O	N.C.
27	TRD	O	Tracking drive output
28	FOD	O	Focus drive output
29	VREF	I	D/A (drive) output (TVD, ECS, TRD, FOD, FBAL, TBAL) Reference voltage input
30	FBAL	O	Focus balance adjustment output
31	TBAL	O	Tracking balance adjustment output
32	FE	I	Focus error signal input (analog input)
33	TE	I	Tracking error signal input (analog input)
34	RFENV	I	RF envelope signal input
35	VDET	I	Vibration detection signal input ("H" : detection)
36	OFT	I	Off-track signal input ("H" : off track)
37	TRCRS	I	Track cross signal input
38	/RFDET	I	RF detection signal input ("L" : detection)
39	BDO	I	Dropout signal input ("H" : Dropout)
40	LDON	O	Laser on signal output ("H" : ON)
41	PLL2	I/O	N.C.
42	DSL2	O	Tracking Offset alignment output/DSL Balance Output (DA Output)
43	WVEL	O	N.C.
44	ARF	I	RF signal input
45	IREF	I	Reference current input
46	DRF	I	DSL bias terminal (Not used, open)
47	DSL2	I/O	DSL loop filter terminal
48	PLL2	I/O	PLL loop filter terminal
49	VCO2	I/O	VCO loop filter terminal
50	AVDD2	I	Power supply input (for analog circuit)
51	AVSS2	I	GND (for analog circuit)

No.	Mark	I/O	Function
52	EFM	-	EFM signal output
53	PCK	-	PLL extraction clock output (fPCK = 4.321 MHz during normal playback)
54	VCOF2	I/O	VCO Loop filter for 33.8688 MHz conversation terminal for 16.9344 MHz crystal mode, must use other circuit
55	SUBC	O	Sub-code serial data output
56	SBCK	I	Clock input for sub-code serial data
57	VSS	I	GND
58	X1 IN	I	Crystal oscillating circuit input (f = 16.9344MHz)
59	X2 OUT	O	Crystal oscillating circuit input (f = 16.9344 MHz)
60	VDD	I	Power supply input (for oscillating circuit)
61	BYTCK	-	Byte clock output
62	/CLDCK	-	Sub-code frame clock signal output (fCLDCK = 7.35 kHz during normal playback)
63	FCLK	-	Crystal frame clock signal output (fCLK = 7.35 kHz, double = 14.7 kHz)
64	IPFLAG	-	Interpolation flag output ("H" : Interpolation)
65	FLAG	-	Flag output

No.	Mark	I/O	Function
66	CLVS	-	Spindle servo phase synchronizing signal output ("H" : CLV, "L" : rough servo)
67	CRC	-	Sub-code CRC checked output ("H" :OK, "L" :NG)
68	DEMPH	-	De-emphasis ON signal output ("H" :ON)
69	RESY	-	Frame re-synchronizing signal output
70	IOSEL	I	Mode switching terminal
71	/TEST	I	Test input
72	AVDD1	I	Power supply input (for analog circuit)
73	OUTL	O	Left channel audio signal output
74	AVSS1	I	GND
75	OUTR	O	Right channel audio signal output
76	RSEL	I	RF signal polarity assignment input (at "H" level, RSEL="H", at "L" level, RSEL="L")
77	IOVDD	I	5V supply input
78	PSEL	I	Test terminal (connected to Gnd)
79	MSEL	I	SMCK oscillating frequency designation input ("L" :4.2336 MHz, "H" :8.4672 MHz)
80	SSEL	I	SUBQ output mode select ("H" :Q-code buffer mode)

13.3. IC703 (AN8739SBE2) Focus coil/ Tracking coil/ Traverse motor/ Spindle motor driver

No.	Mark	I/O	Function
1	/RST	-	RESET output terminal
2	NC	-	N.C.
3	IN2	I	Motor Drive (2) input
4	PC2	I	Turntable motor drive signal (L : "ON")
5	NC	-	N.C.
6	IN1	I	Motor driver (1) input
7	NC	I	N.C.
8	PVCC1	I	Power supply (1) for driver
9	PGND1	-	Ground connection (1) for driver
10	NC	-	N.C.
11	D1-	O	Motor driver (1) reverse-action output
12	D1+	O	Motor driver (1) forward-action output
13	D2-	O	Motor driver (2) reverse-action output
14	D2+	O	Motor driver (2) forward-action output

No.	Mark	I/O	Function
15	D3-	O	Motor driver (3) reverse-action output
16	D3+	O	Motor driver (3) forward-action output
17	D4-	O	Motor driver (4) reverse-action output
18	D4+	O	Motor driver (4) forward-action output
19	NC	-	N.C.
20	PGND2	-	Ground connection (2) for driver
21	PVCC2	I	Power supply (2) for driver
22	NC	-	N.C.
23	VCC	I	Power supply terminal
24	VREF	I	Reference voltage input
25	IN4	I	Motor driver (4) input
26	IN3	I	Motor driver (3) input
27	RSTIN	I	Reset terminal
28	NC	-	N.C.

13.4. IC600 (M38199MF227) System Microprocessor

No.	Mark	I/O	Function
1	CRT/SER 4	I/O	CRT Timer/ (SP_LTH) latch signal for ASP
2	TPS	I	Tape Mecha TPS input
3	DECK 1	I	Tape Mecha condition input (HALF 1/ MODE/ PHOTO 1/PHOTO 2)
4	DECK 2	I	Tape Mecha condition input (HALF 2/ RECI_F/ MODE/ RECI_R)
5	KEY 4	I	Key 4 input
6	KEY 3	I	Key 3 input
7	KEY 2	I	Key 2 input

No.	Mark	I/O	Function
8	KEY 1	I	Key 1 input
9	SER 1	O	Serial Data/Clock (D_CLK, F_CLK)
10	SER 2	O	Serial Data/Clock (MKDATA, D_DAT)
11	SER 3	O	Serial Data/Clock (F_DAT, SP_DAT)
12	SER 5	O	Deck Control/ASP Clock output (MKCLK, SP_CLK)
13	SPE	I	Speana input
14	V_JOG_AB	I	Volume jog A-D detection input

No.	Mark	I/O	Function
15	J_JOG_AB	I	EQ Joy jog A-D detection input
16	CHG_AD1	I	(OPEN/CLAMP)Changer switch A-D detection input 1
17	CHG_AD2	I	(POSITION/BOTTOM) Changer switch A-D detection input 2
18	CDRST	I/O	CD RESET output
19	STATUS	I	CD Signal Processor status input (INV)
20	SQCLK	I/O	Tuner IF data/ Stereo input and CD Subcode Clock output
21	SD	I/O	Tuner Signal detect input
22	ST/DO/SUBQ	I	CD Subcode data input (INV)
23	CHG_CW	O	Changer motor CW output
24	CHG_CCW	O	Changer motor CCW output
25	CHG_HALF	O	Changer half drive output
26	MLD/PPLCE	O	CD command load output/Tuner PLL chip enable
27	MDATA/ PLLDA	O	CD command data output/Tuner PLL data output
28	MDATA/ PLLCLK	O	CD command clock output/Tuner PLL clock output
29	RESTSW	I	CD limit switch input for the most inner point
30	BLKCK	I	CD block clock input (INV)
31	RMT	I	Remote control input
32	DCDET	I	DC detect input
33	ECONO	O	Main transformer control output for economy mode
34	SYNC	I	AC failure detect input
35	RESET	-	RESET input
36	XCIN	-	X'tal oscillator (f = 32.768 kHz sub clock)
37	XCOU	-	X'tal oscillator (f = 32.768 kHz sub clock)
38	XIN	-	X'tal oscillator (f = 8.0 MHz main clock)
39	XOUT	-	X'tal oscillator (f = 8.0 MHz main clock)
40	VSS	-	Ground (0V)
41	MBP1	O	MPU beat proof output 1
42	MBP 2	O	MPU beat proof output 2
43	CHG_SW 2	I/O	CD changer switch 2 input
44	CHG_SW 1	I/O	CD changer switch 1 input
45	CHG_PLGR	O	Changer plunger output
46	SP_A	O	Speana control output A
47	SP_B	O	Speana control output B
48	SP_C	O	Speana control output C
49-54	GRD8-GRD13	O	Digit drive output (Grid drive output)
55-61	GRD1-GRD7	O	Digit drive output (Grid drive output)
62-83	SEG32-SEG11	O	Segment drive output (Anode drive output)
84-90	SEG10-SEG4/REG10-REG4	O	Segment drive output (Anode drive output)/For region setting/Function selection use/Key scan output at RESET START
91	VCC	-	Power supply (+5V)
92	REG3/SEG3	O	Segment drive output (Anode drive output)
93	REG2/SEG2	O	For region setting/Function selection use
94	REG1/SEG1	O	Key scan output at RESET START
95	REG_IN/EECS	I/O	Region and function setting input and EEPROM clock output

No.	Mark	I/O	Function
96	EEDAT	-	EEPROM data input
97	EECLK	-	EEPROM chip select output
98	VEE	-	Power supply (-30V)
99	AVSS	-	Analog Ground (0V)
100	VREF	-	Reference for A-D

14 Block Diagram

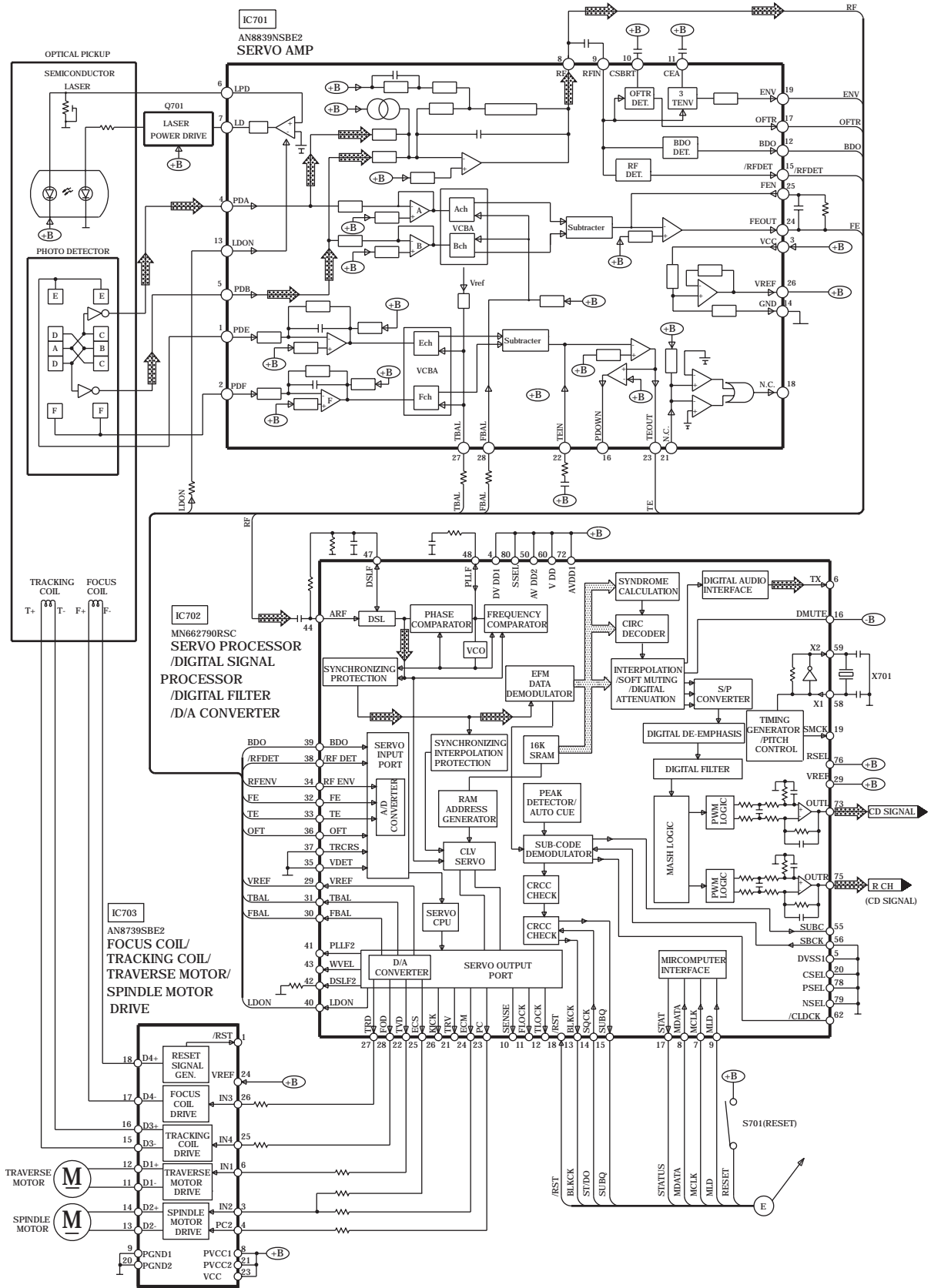

This page is only applicable for GN/GT areas

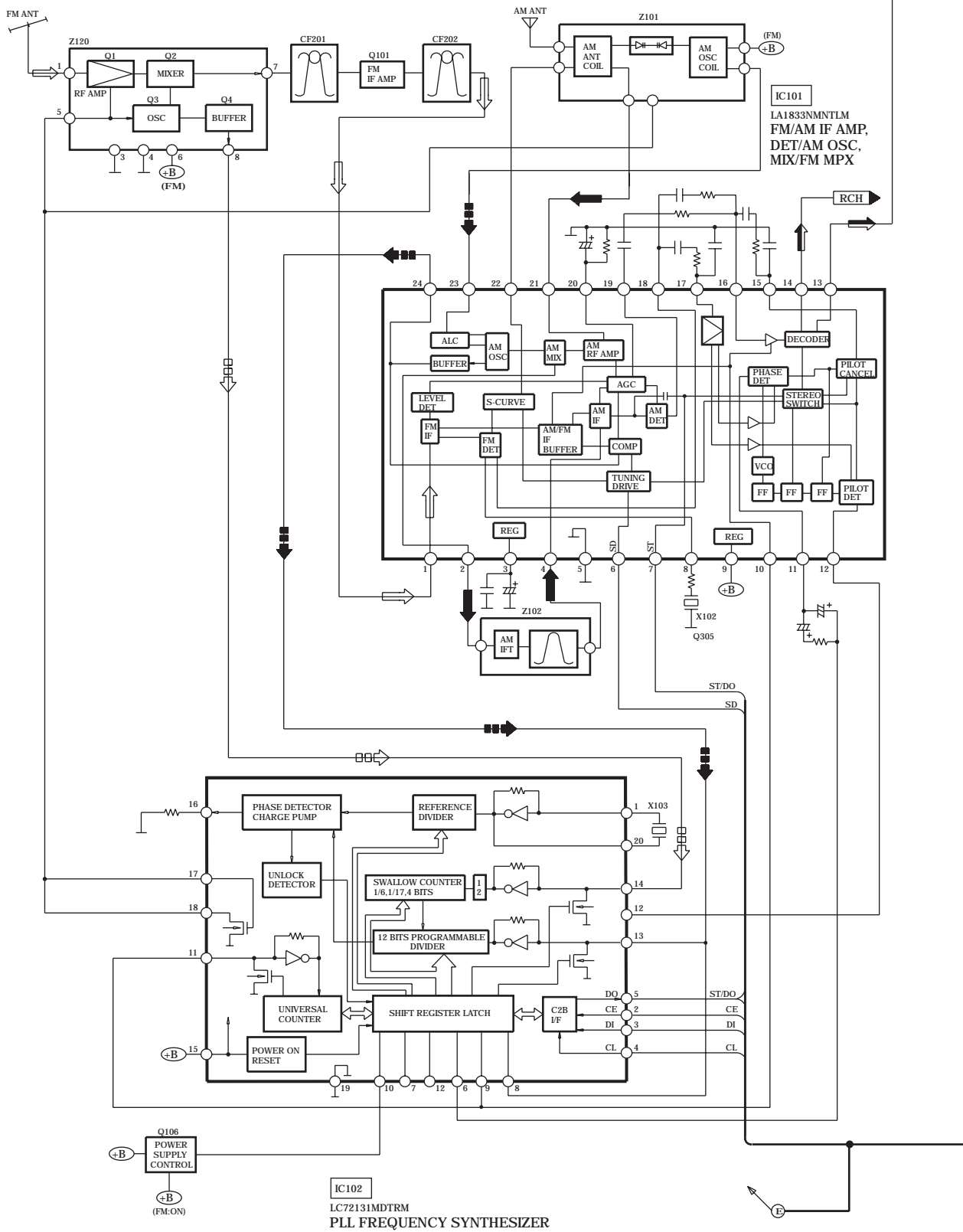

This page is only applicable for GC areas

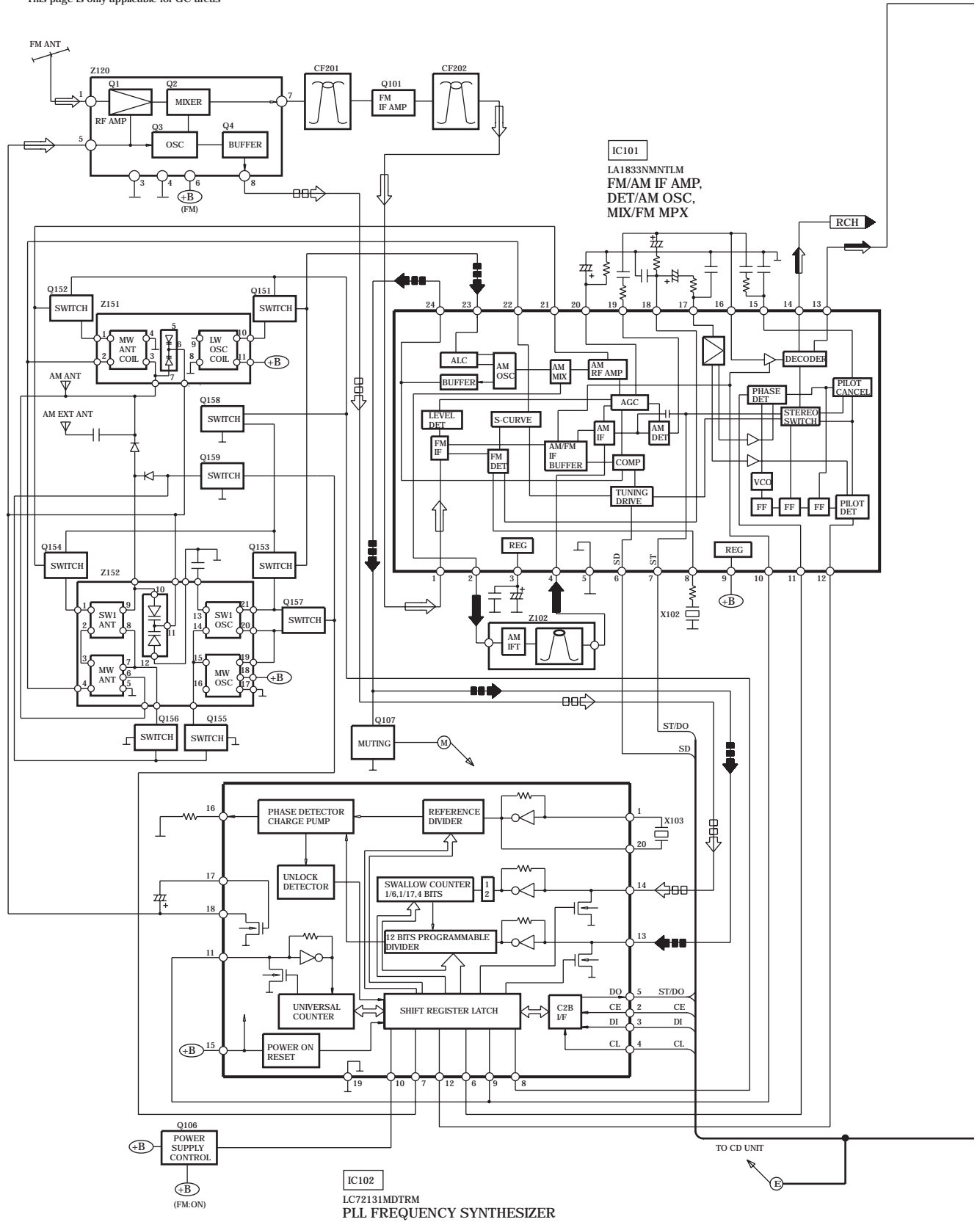

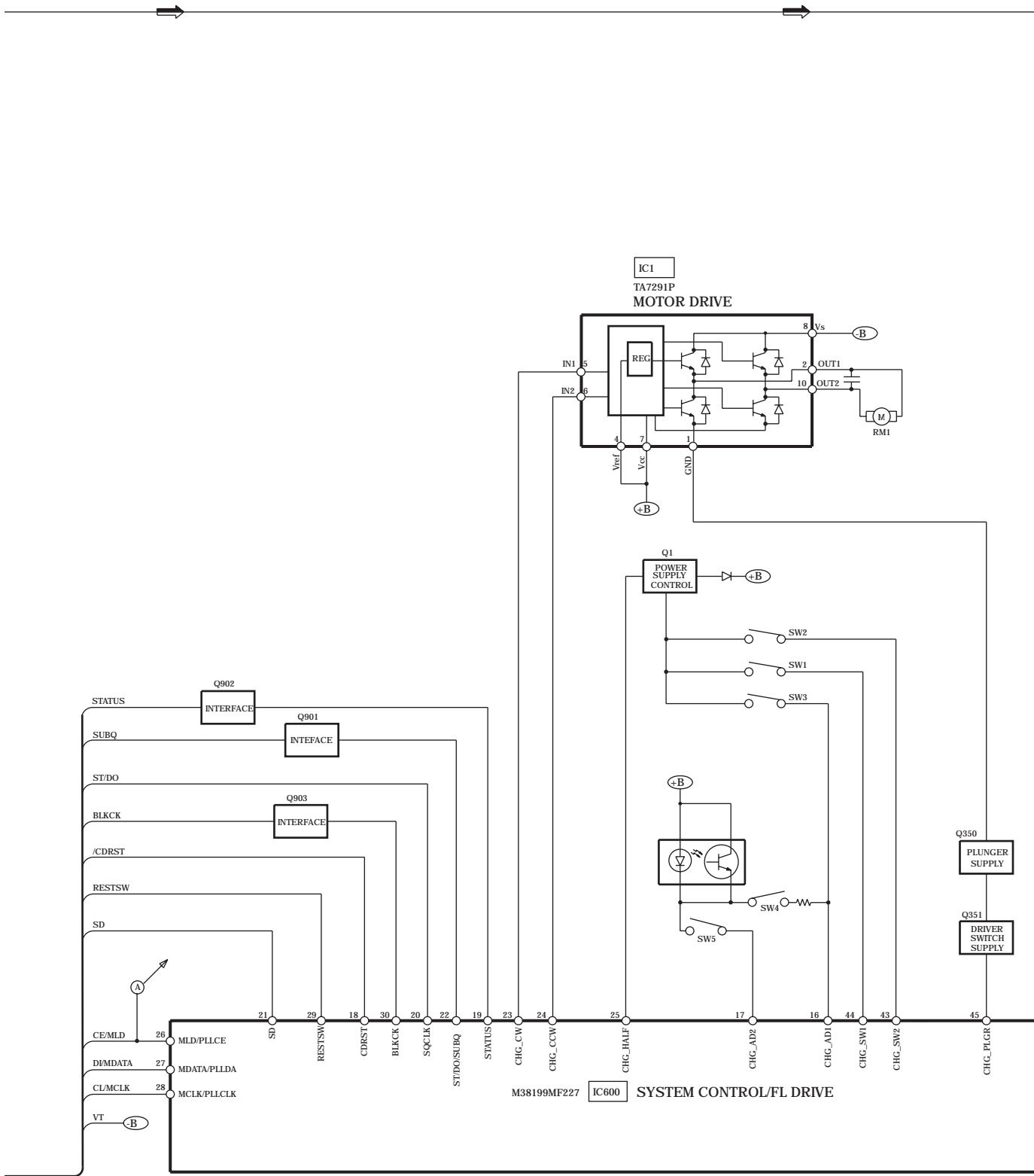

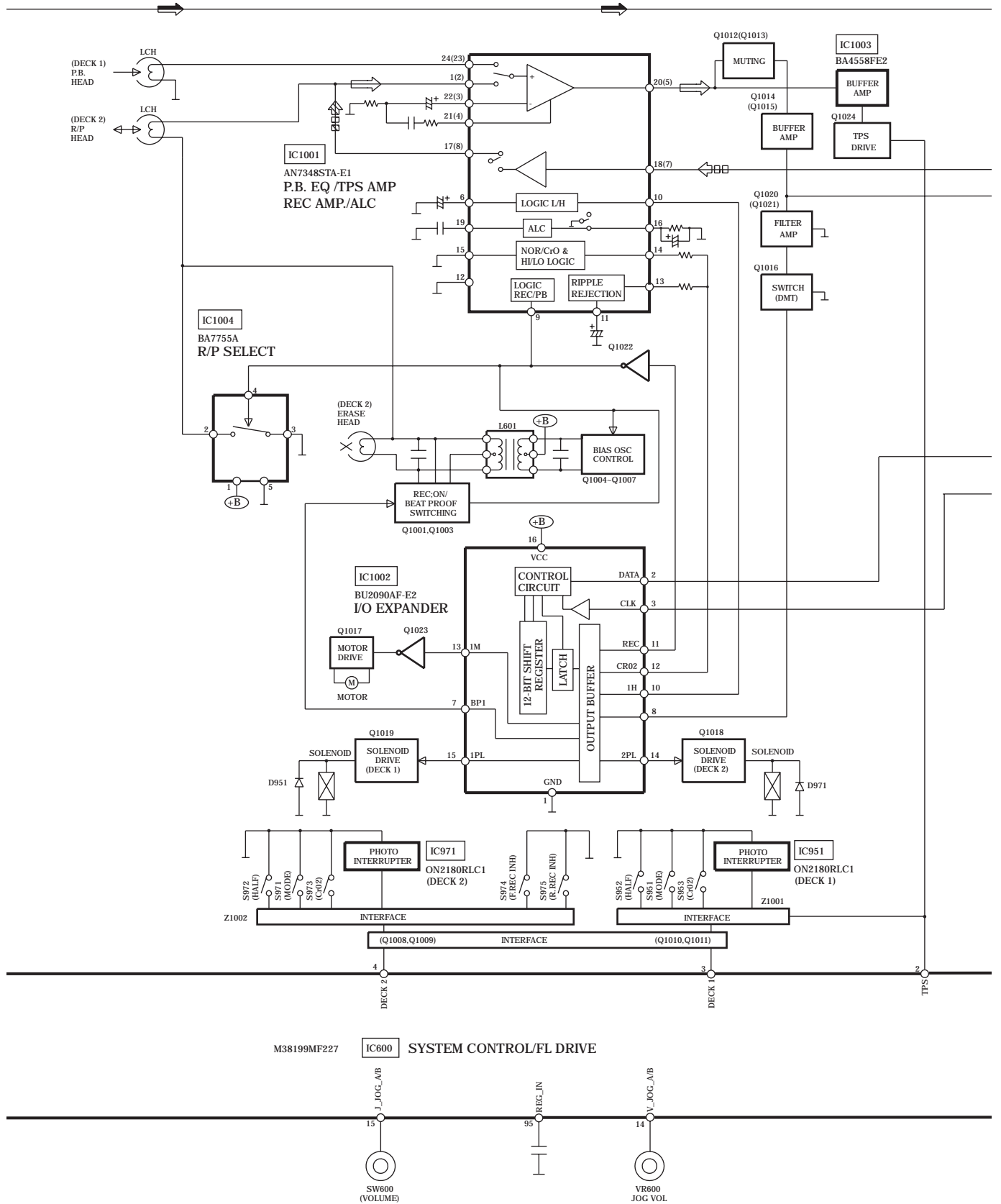

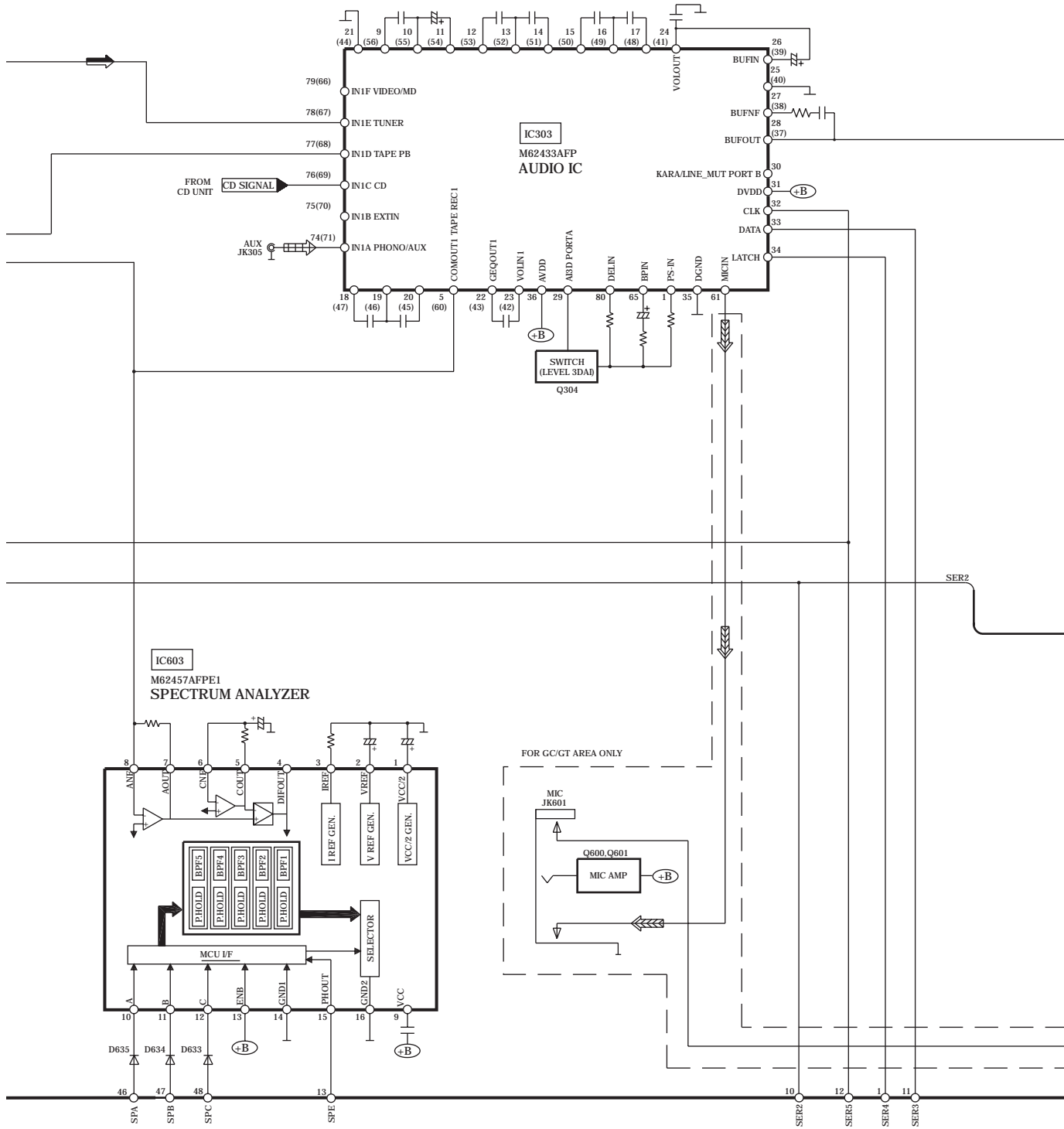

M38199MF227 IC600 SYSTEM CONTROL/FL DRIVE

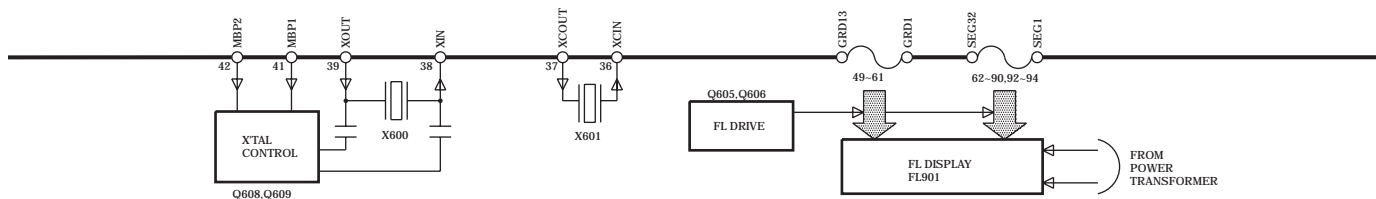

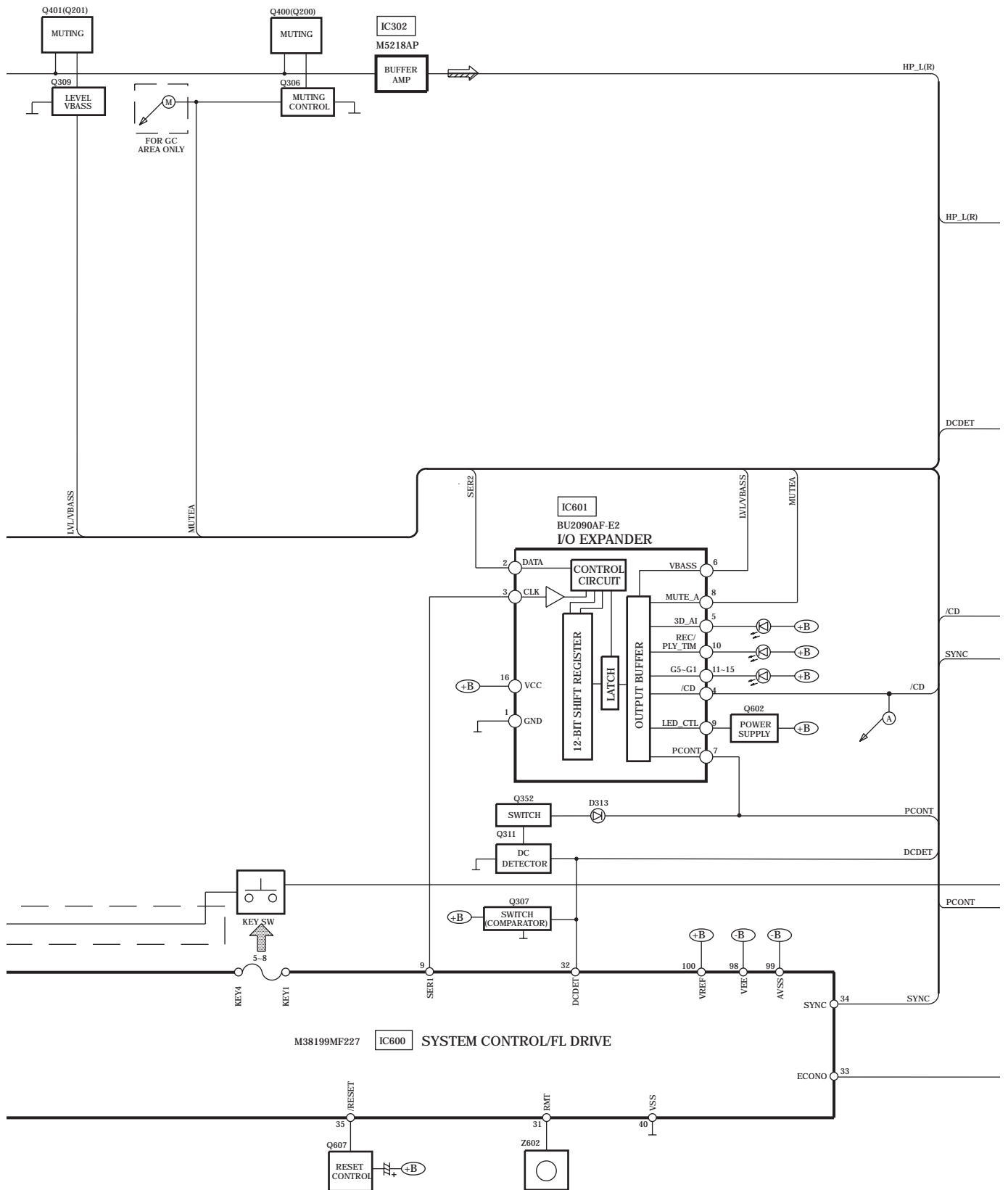

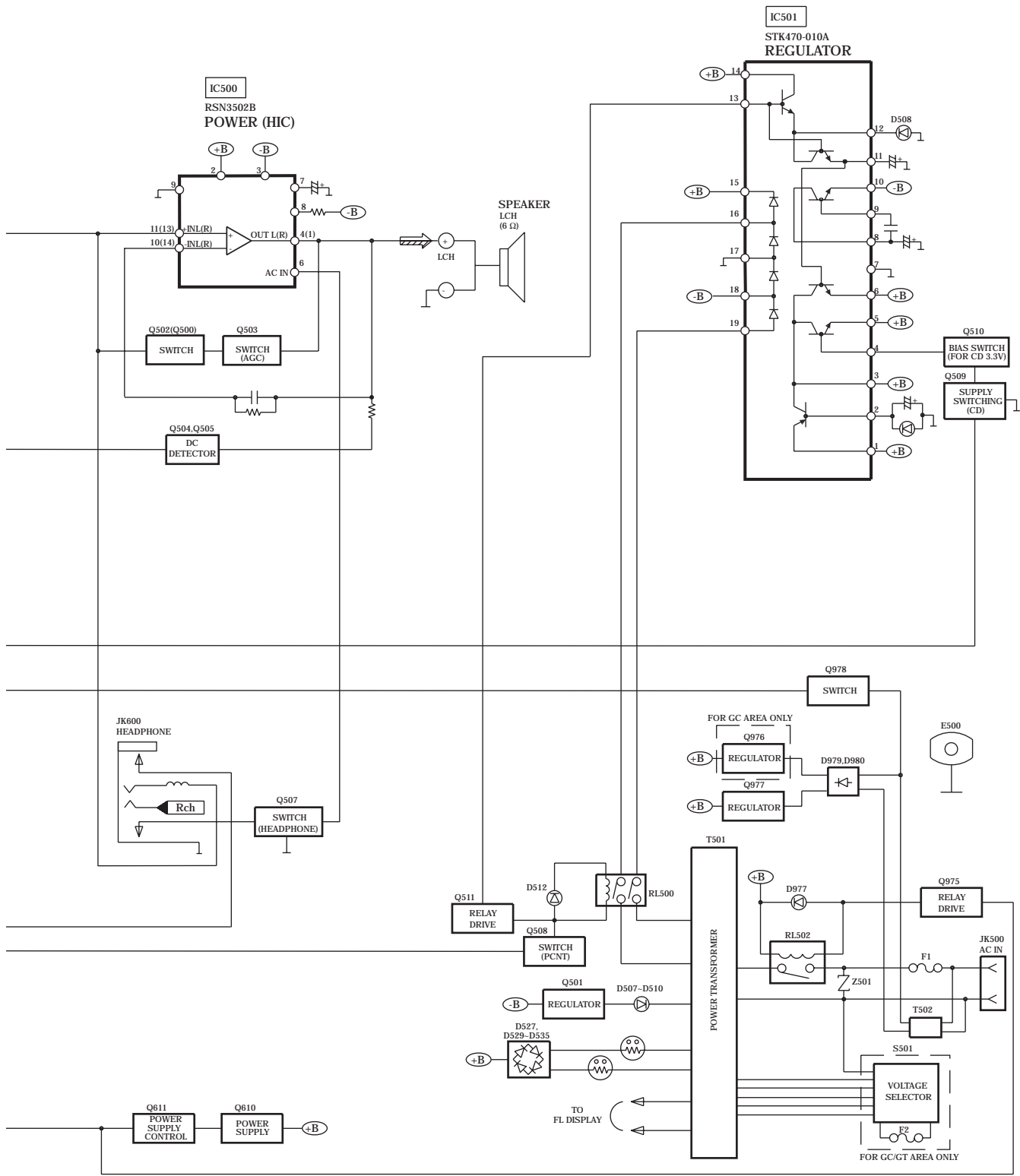

SIGNAL LINES

() indicates Pin No. of right channel.

15 Schematic Diagram

(All schematic diagrams may be modified at any time with the development of the new technology)

Note:

S501	Voltage selector switch
S701	Reset switch
S602	AUX select switch
S603	Deck 1 eject switch
S604	CD Manager switch
S605	Band/Tuner select switch
S606	Tape Edit switch
S607	Disc 5 eject switch
S608	CD select switch
S609	Rec/Stop select switch
S610	Disc 5 select switch
S611	Tape/Deck select switch
S612	Reverse Mode select switch
S613	Disc 4 eject switch
S614	EQ adjust down switch
S615	V.Bass switch
S616	Deck 2 eject switch
S617	Disc 4 select switch
S618	EQ adjust left switch
S619	Display, Demonstration switch
S620	Reverse play, Tune/time adjust down switch
S621	Clock, Timer select switch
S622	EQ adjust up switch
S623	Disc 3 eject switch
S624	Karaoke select switch
S625	Play timer/Rec timer select switch

S626	EQ adjust right switch
S627	Disc 3 select switch
S628	Economy Mode switch
S629	Stop,Tune Mode select switch
S630	Disc 2 eject switch
S631	Random play switch
S632	FWD, Memory set switch
S633	Disc 2 select switch
S634	FWD play/pause, Tune/Time adjust up switch
S635	Disc 1 eject switch
S636	Disc 1 select switch
S637	REW, FM Mode/BP select switch
S638	Power switch
S639	3D AI EQ switch
S951	Deck 1 Mode detect switch
S952	Deck 1 Tape detect switch
S953	Deck 1 CrO2 detect switch
S971	Deck 2 Mode detect switch
S972	Deck 2 Tape detect switch
S973	Deck 2 CrO2 detect switch
S974	Deck 2 Record detect switch
S975	Deck 2 Record detect switch
SW1, SW2	Tray position switch
SW3	Tray open switch
SW4	CD offset detect switch
SW5	Spindle bottom position detect switch
SW600	Sound Equalizer select switch
VR600	Volume control
VR601	MIC level control

- The voltage value and waveforms are the reference voltage of this unit measured by DC electronic voltmeter (high impedance) and oscilloscope on the basis of chassis. Accordingly, there may arise some error in voltage values and waveforms depending upon the internal impedance of the tester or the measuring unit.

No mark : Playback

<< >> : Rec

< > : FM

(()) : CD

() : AM

• Importance safety notice:

Components identified by \triangle mark have special characteristics important for safety. Furthermore, special parts which have purposes of fire-retardant (resistors), high-quality sound (capacitors), low-noise (resistors), etc. are used. When replacing any of components, be sure to use only manufacturer's specified parts shown in the parts list.

Caution!

IC, LSI and VLSI are sensitive to static electricity.

Secondary trouble can be prevented by taking care during repair.

- Cover the parts boxes made of plastics with aluminium foil.
- Put a conductive mat on the work table.
- Ground the soldering iron.
- Do not touch the pins of IC, LSI or VLSI with fingers directly.

SCHEMATIC DIAGRAM-1

A CD SERVO CIRCUIT

— : + B Line ⇨ : CD Signal Line

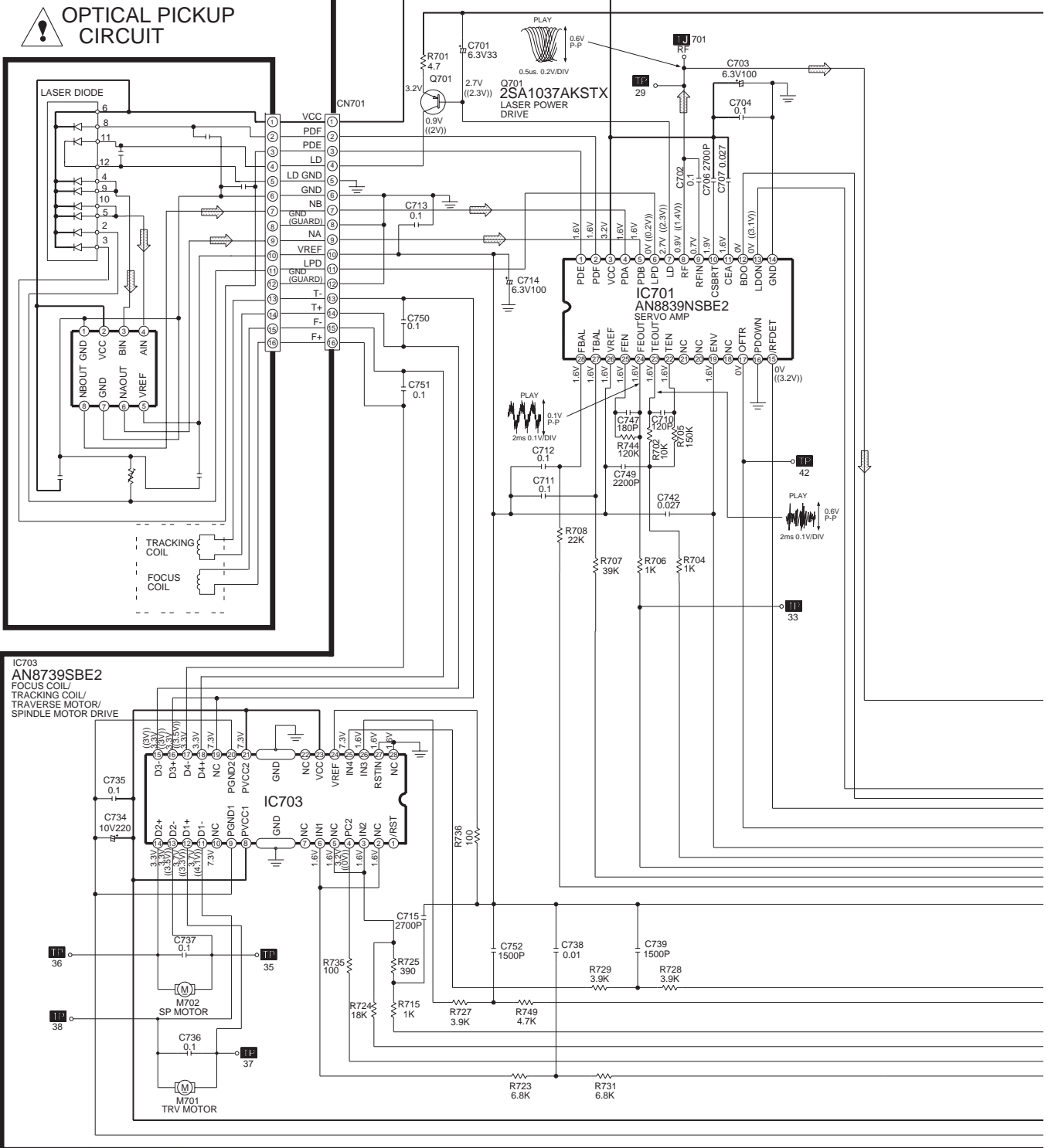

SCHEMATIC DIAGRAM-2

— : + B Line ⇨ : CD Signal Line

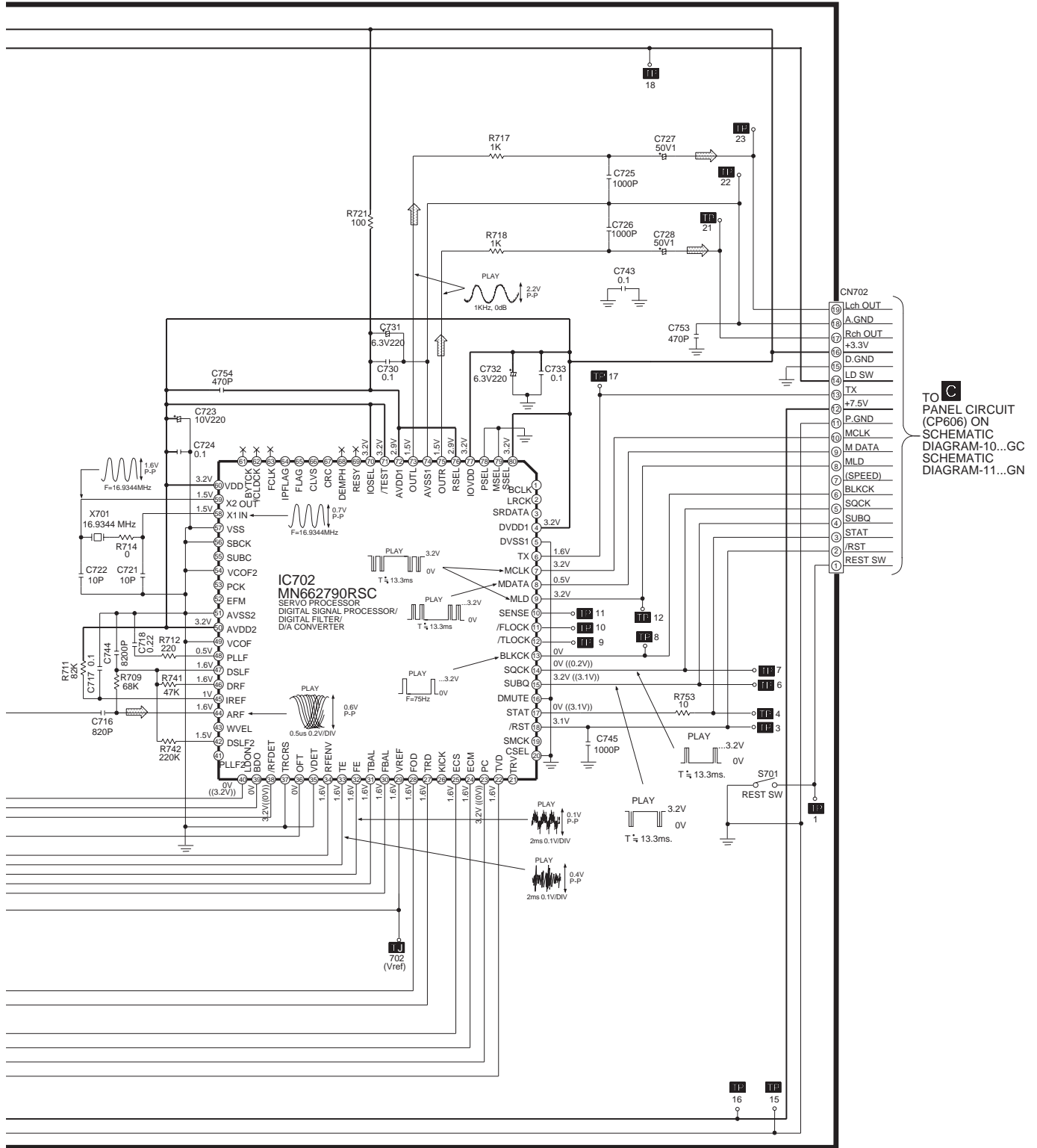

SCHEMATIC DIAGRAM-3

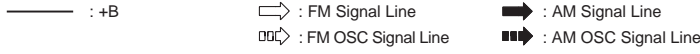

B MAIN/TUNER CIRCUIT (FOR GC ONLY)

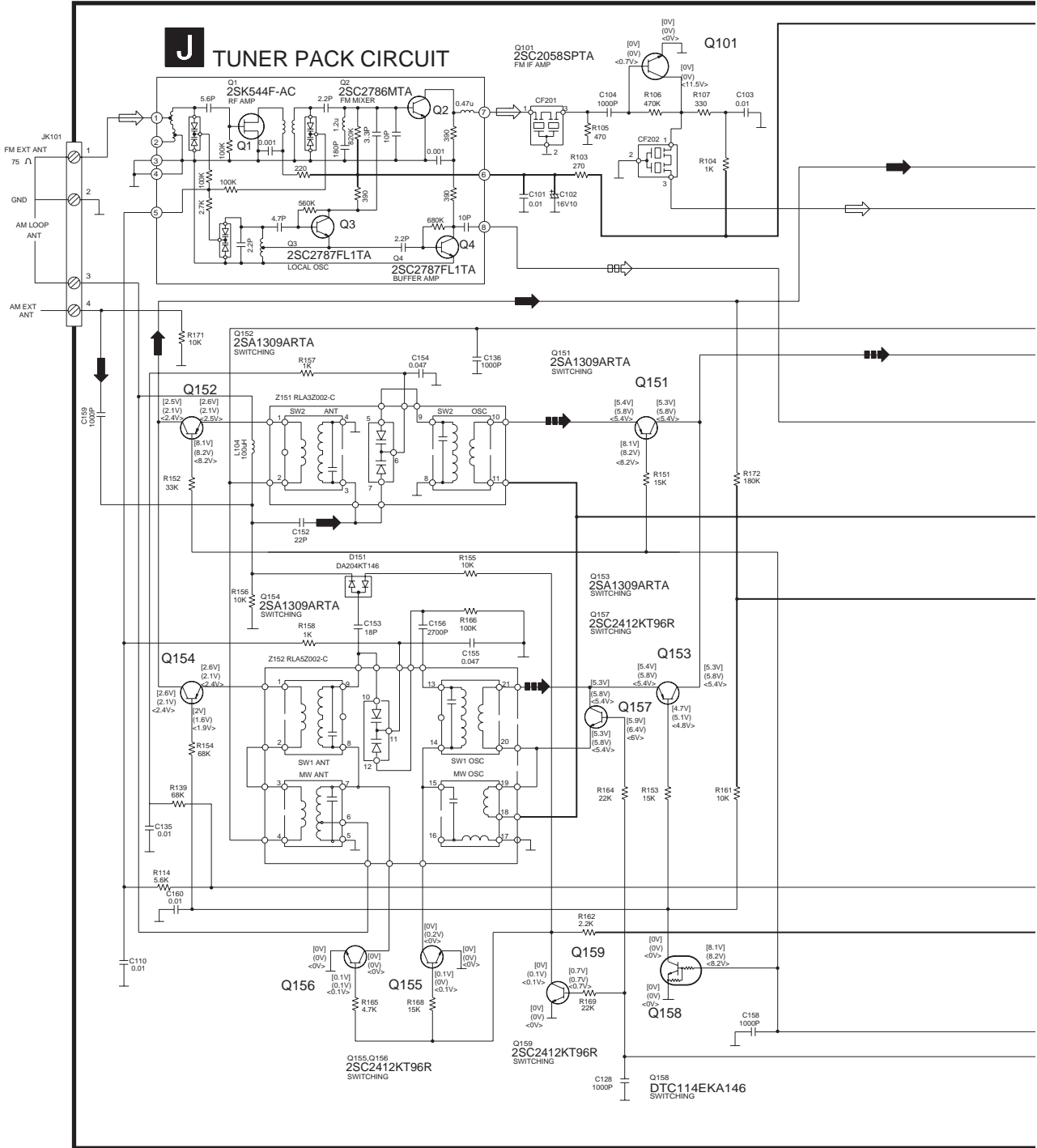

SCHEMATIC DIAGRAM-4

- : +B Line
- ⇨ : FM/AM Signal Line
- ⇨ : FM Signal Line
- ⇨ : AM Signal Line
- ⇨ : FM OSC Signal Line
- ⇨ : AM OSC Signal Line

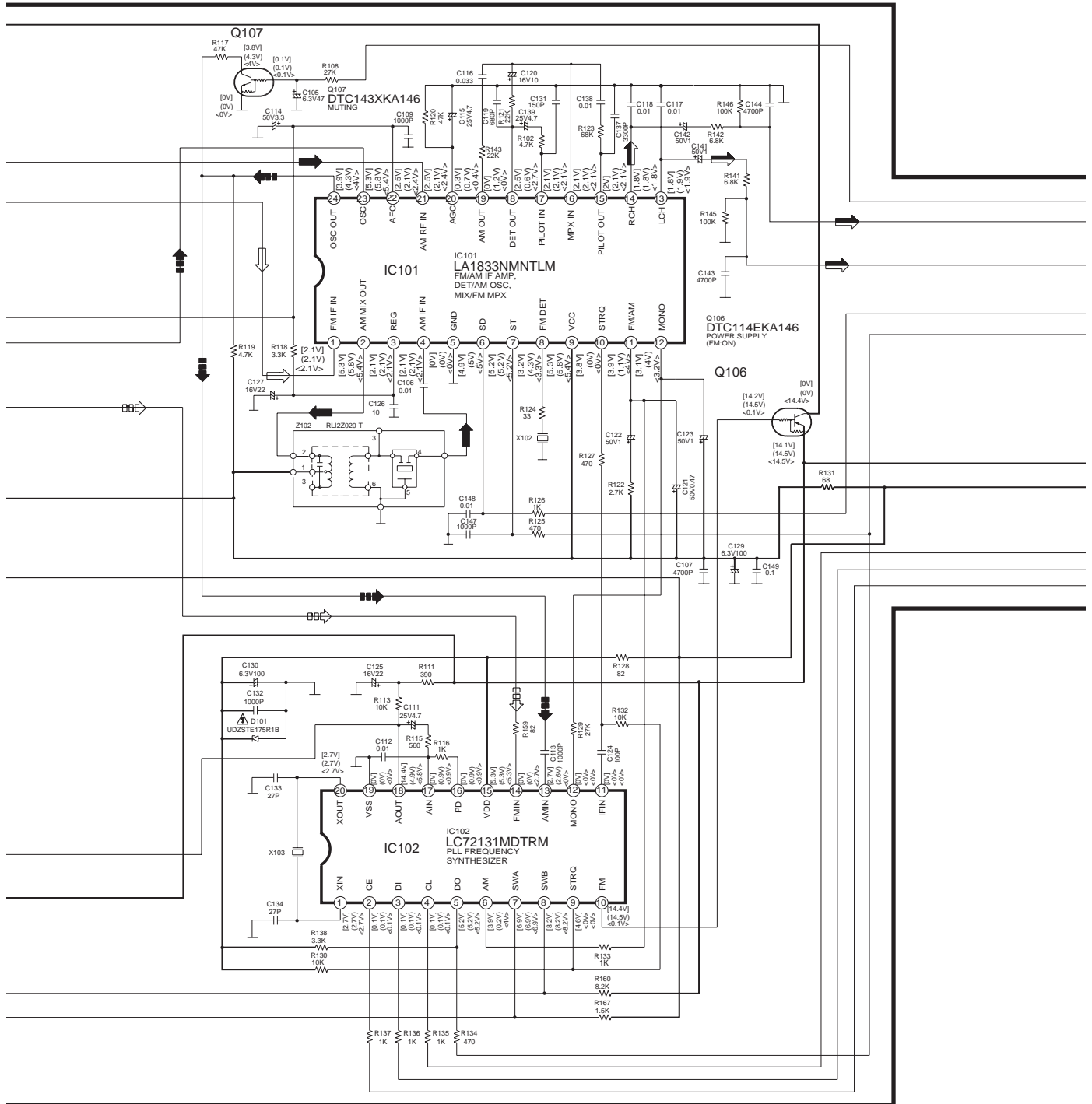

SCHEMATIC DIAGRAM-5

- : +B Line
- - - : -B Line
- ▬▬▬ : Main Signal Line
- ▬▬▬▬ : AUX Signal Line
- ▬▬▬▬▬ : Playback Signal Line
- ▬▬▬▬▬▬ : FM/AM Signal Line
- ▬▬▬▬▬▬▬ : Record Signal Line
- ▬▬▬▬▬▬▬▬ : MIC Signal Line
- ▬▬▬▬▬▬▬▬▬ : CD Signal Line

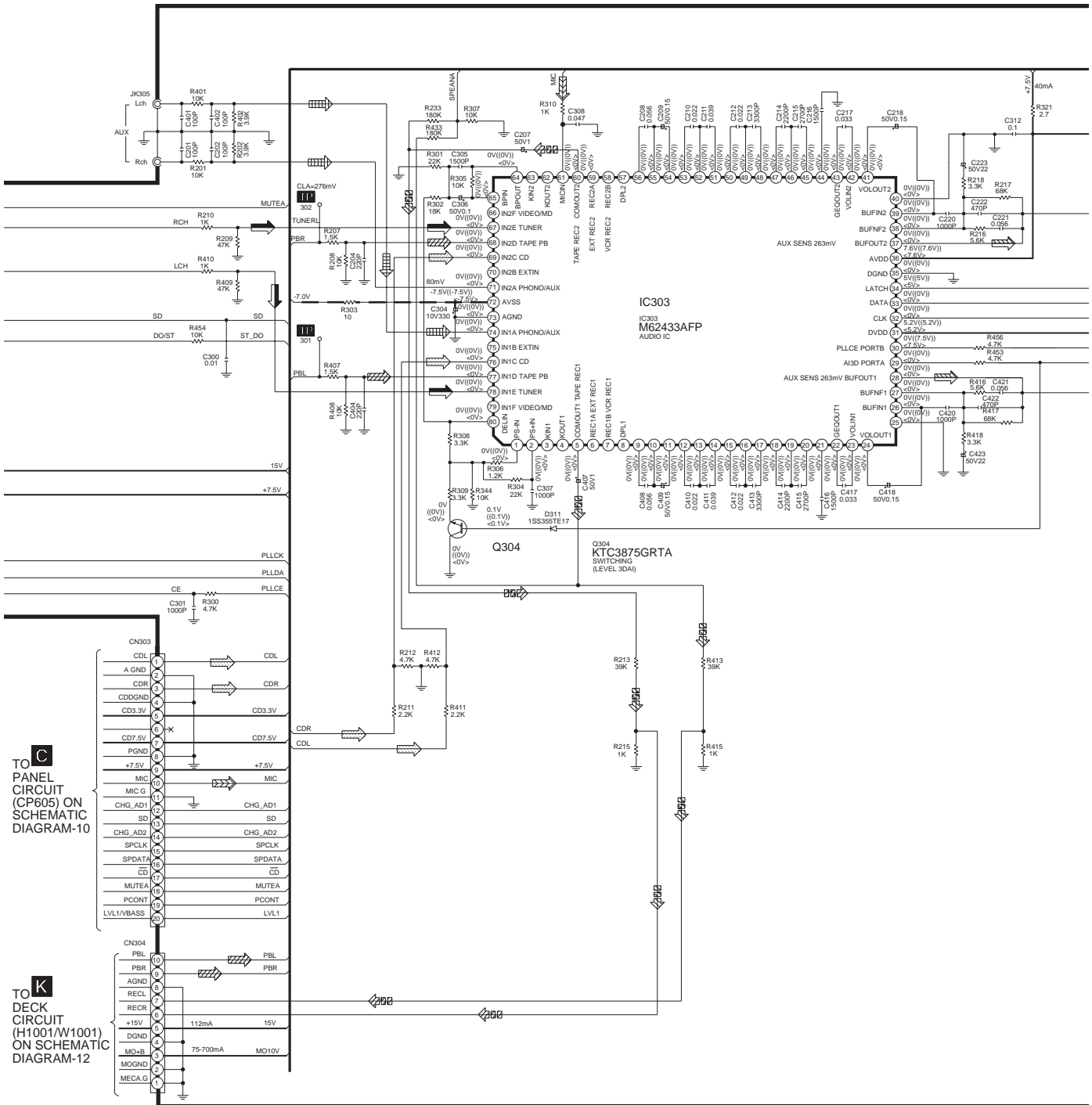

SCHEMATIC DIAGRAM-7

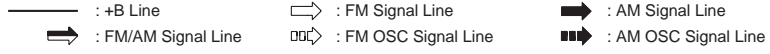

B MAIN/TUNER CIRCUIT (FOR GN ONLY)

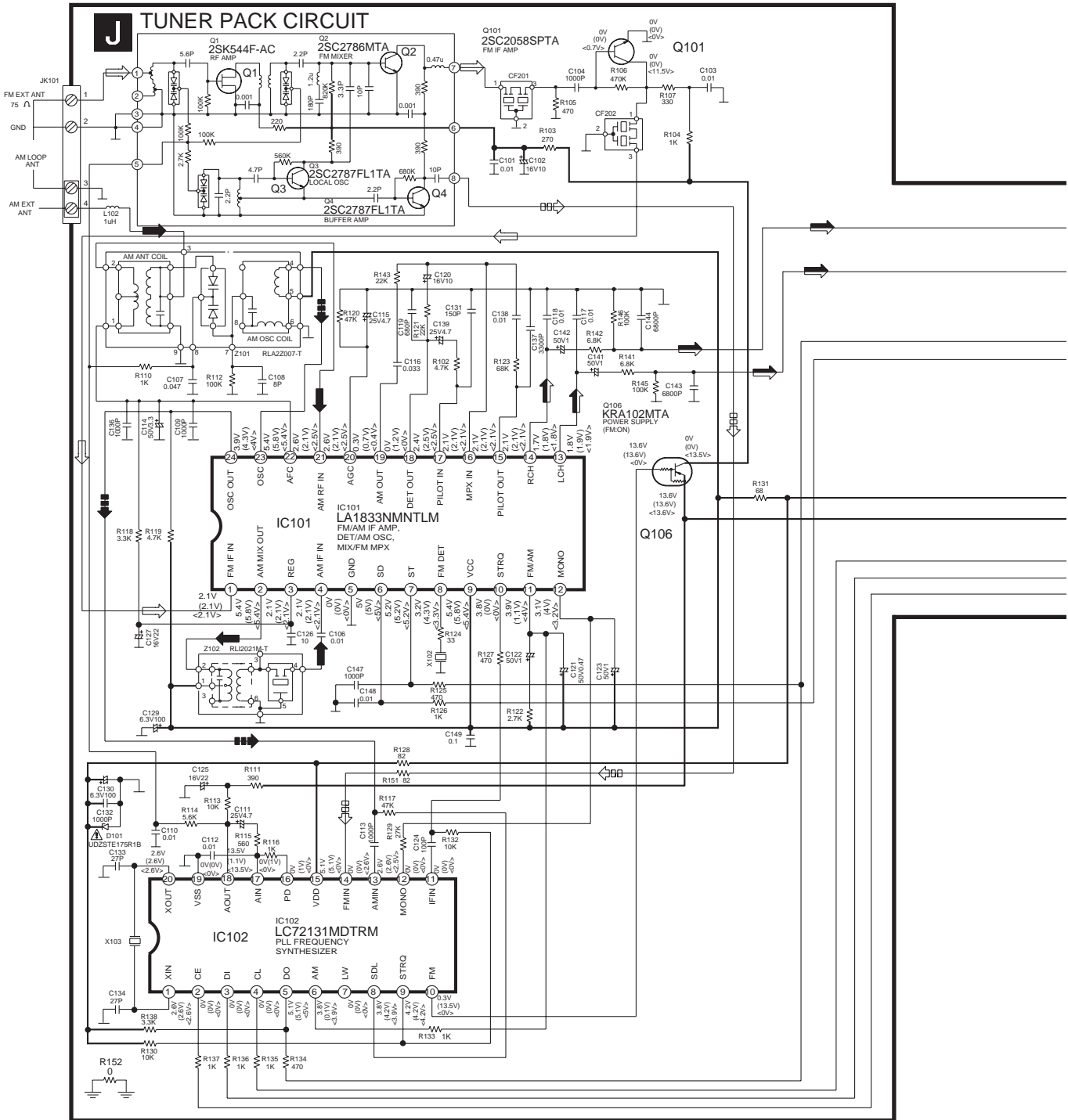

SCHEMATIC DIAGRAM-8



B MAIN/TUNER CIRCUIT

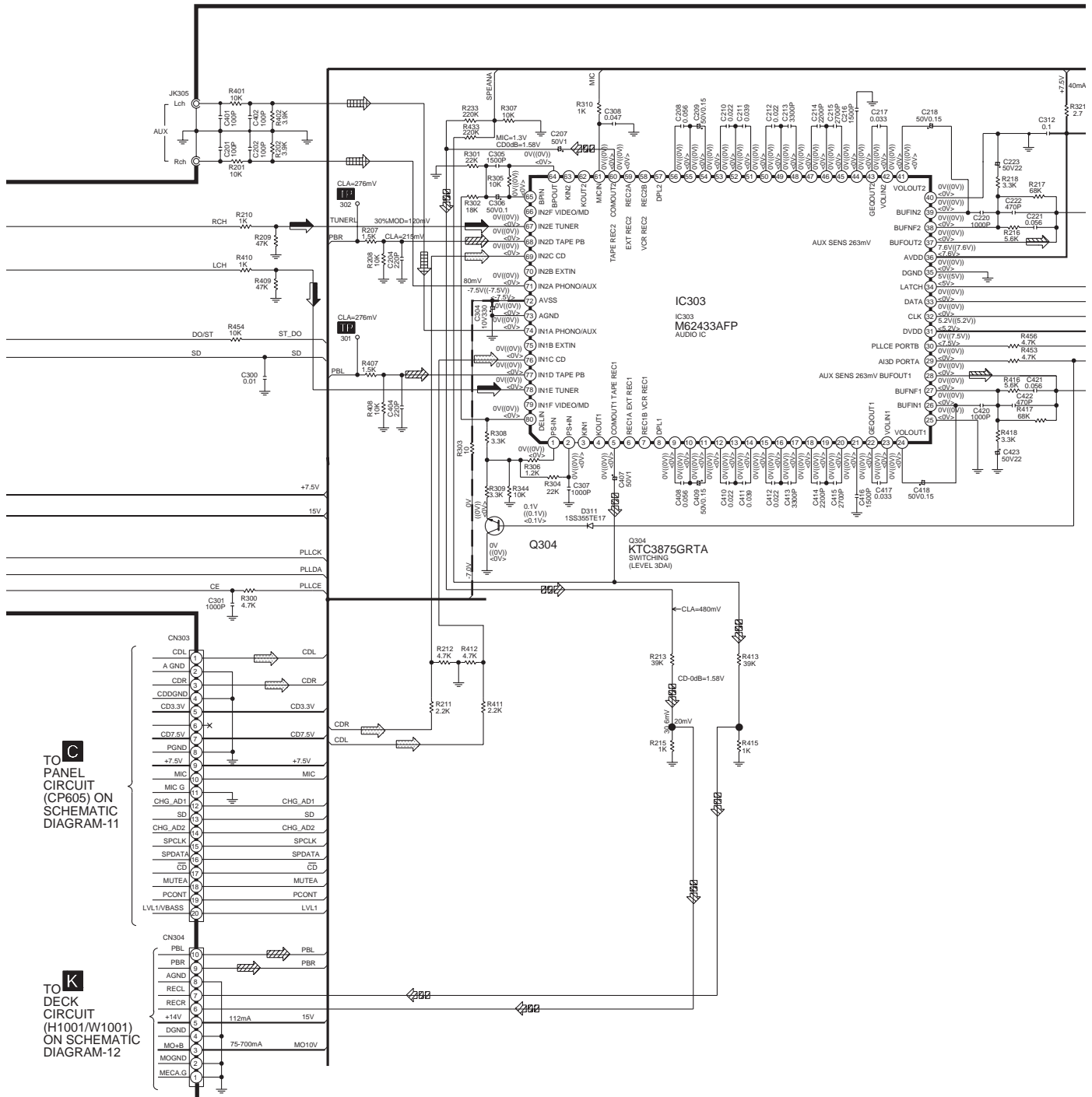

C
TO PANEL CIRCUIT (CP605) ON SCHEMATIC DIAGRAM-11

K
TO DECK CIRCUIT (H1001/W1001) ON SCHEMATIC DIAGRAM-12

SCHEMATIC DIAGRAM-9

— : +B Line - - - - - : -B Line ⇨ : Main Signal Line

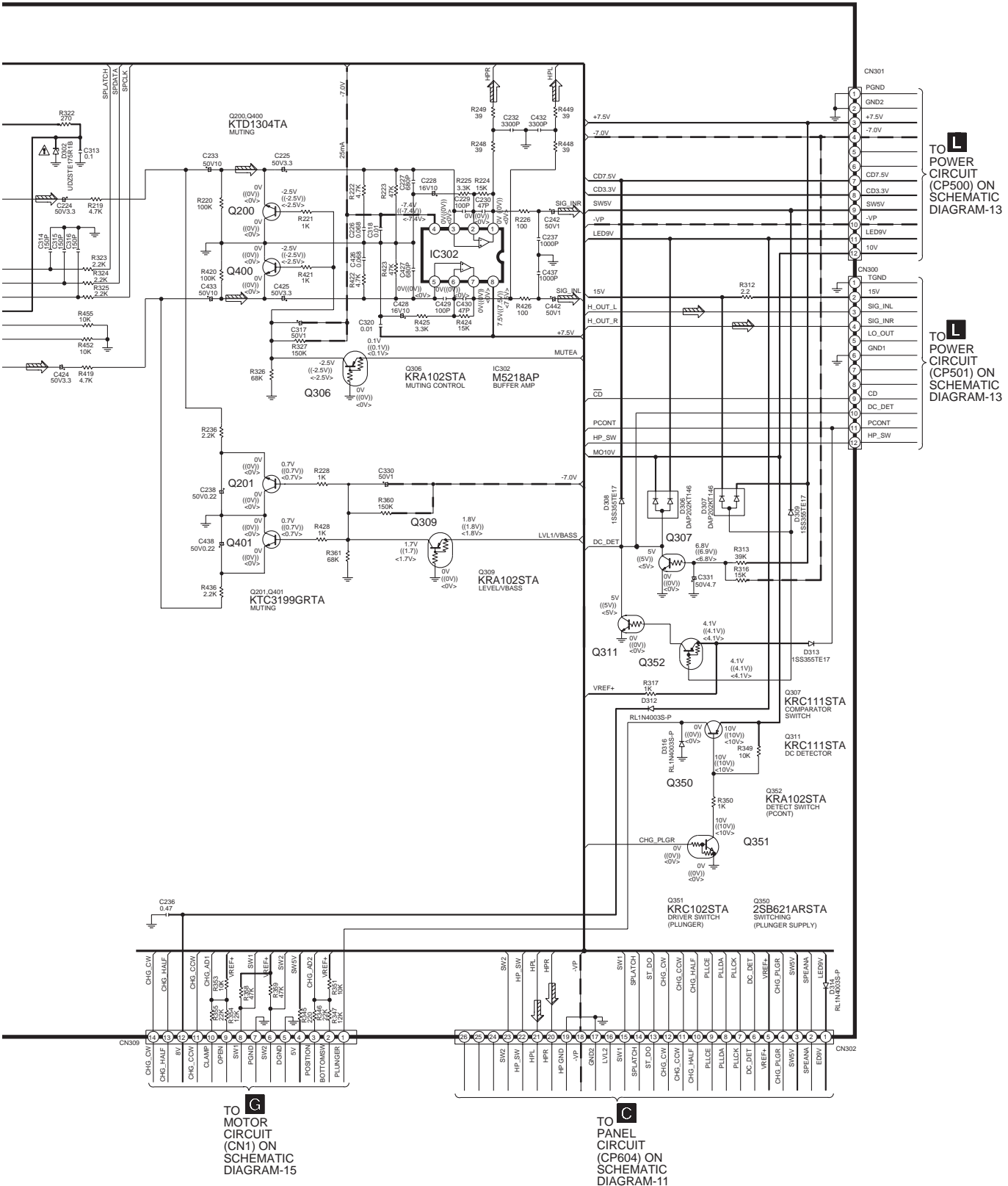

▷D Signal Line

▷▷▷ : MIC Signal Line

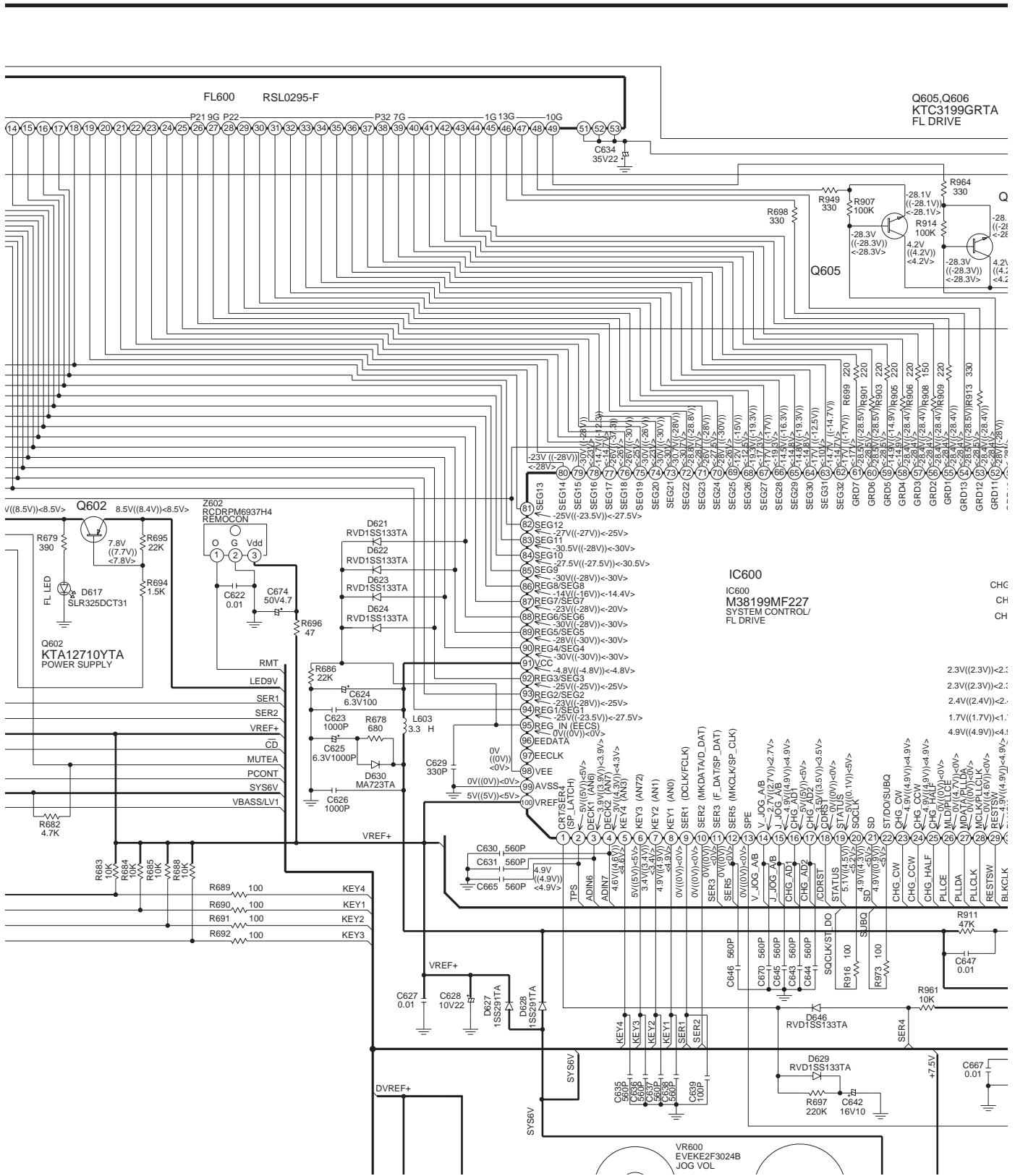

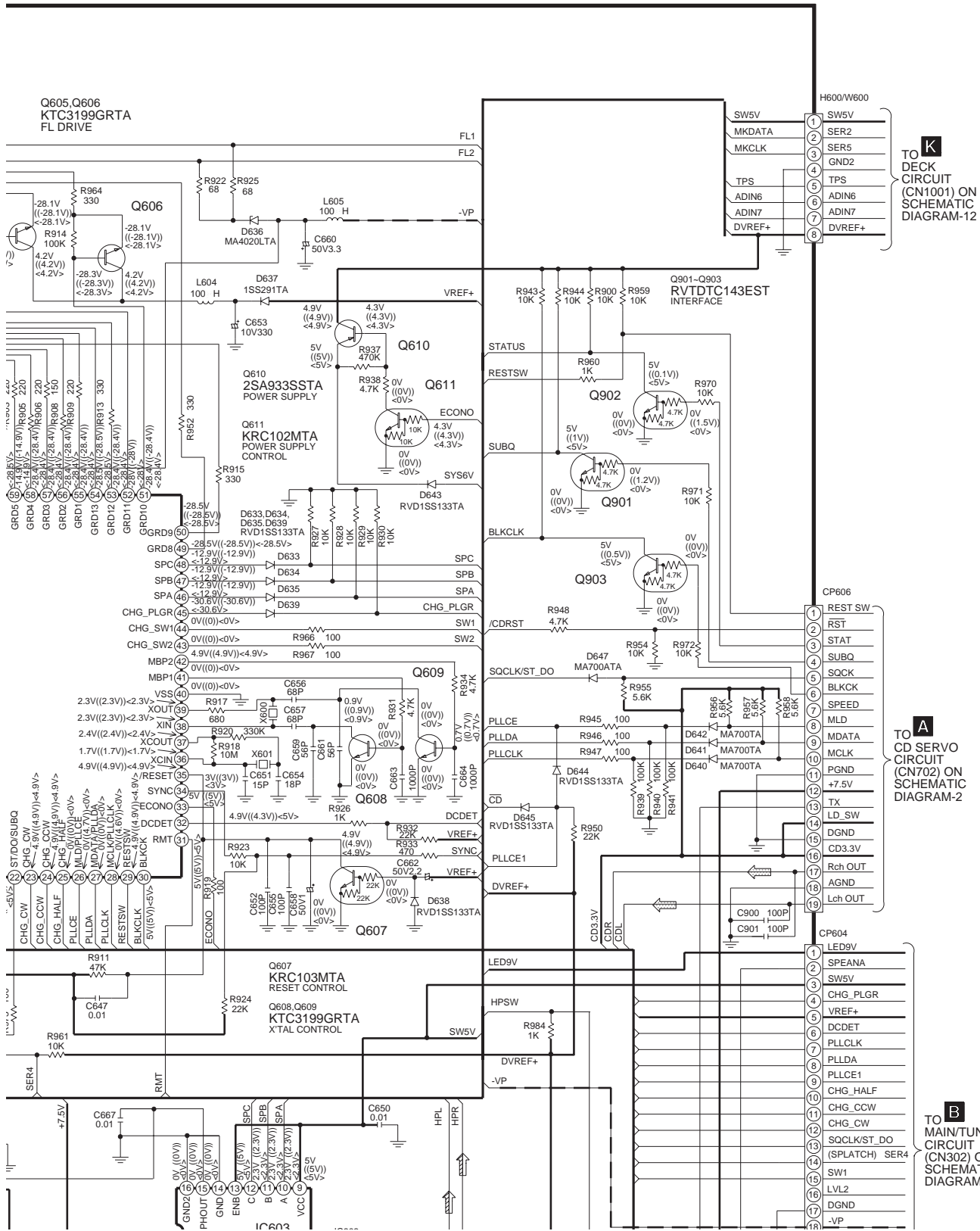

K
TO DECK CIRCUIT (CN1001) ON SCHEMATIC DIAGRAM-12

A
TO CD SERVO CIRCUIT (CN702) ON SCHEMATIC DIAGRAM-2

B
TO MAIN/TUNER CIRCUIT (CN302) ON SCHEMATIC DIAGRAM-6

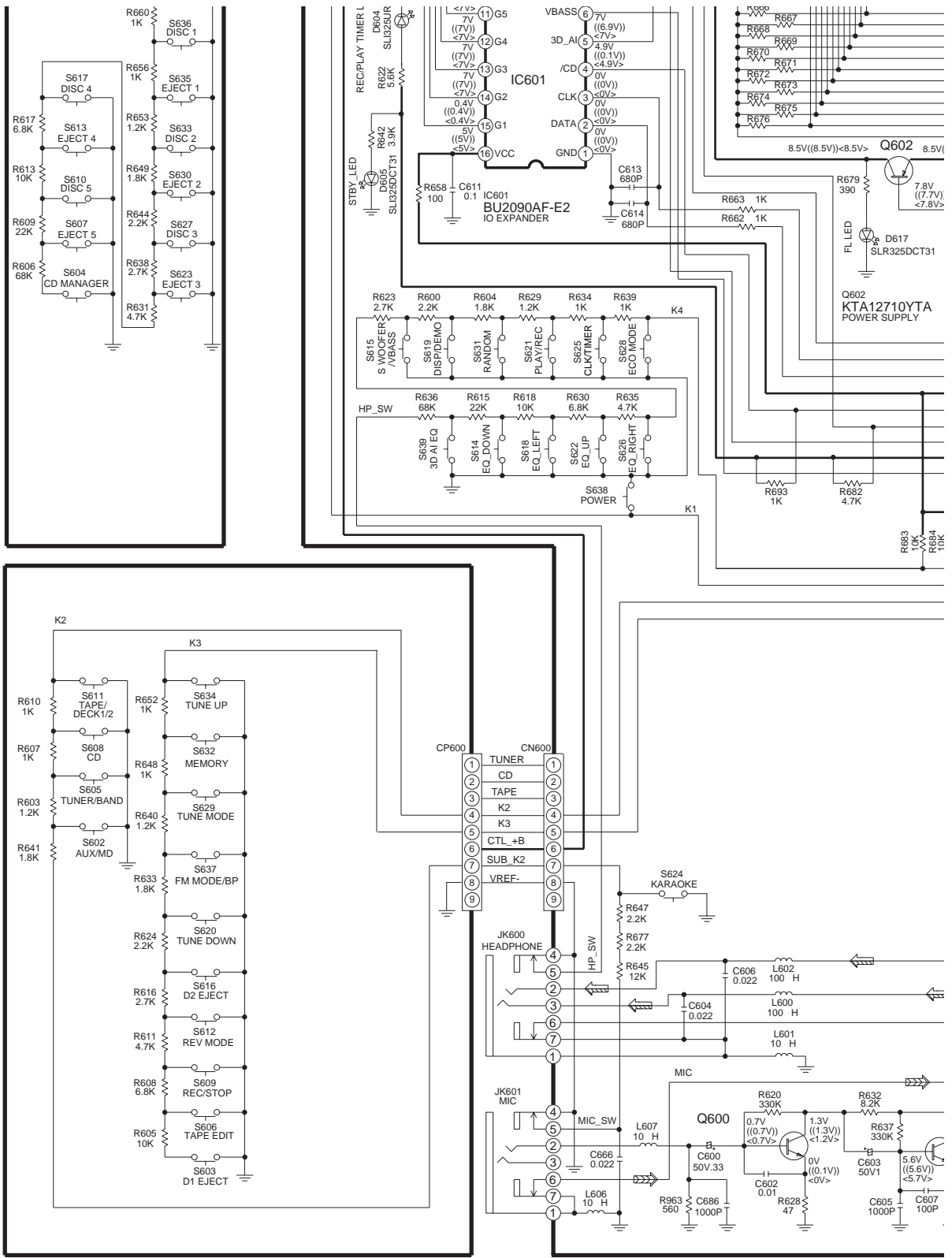

D TACT SWITCH (2) CIRCUIT

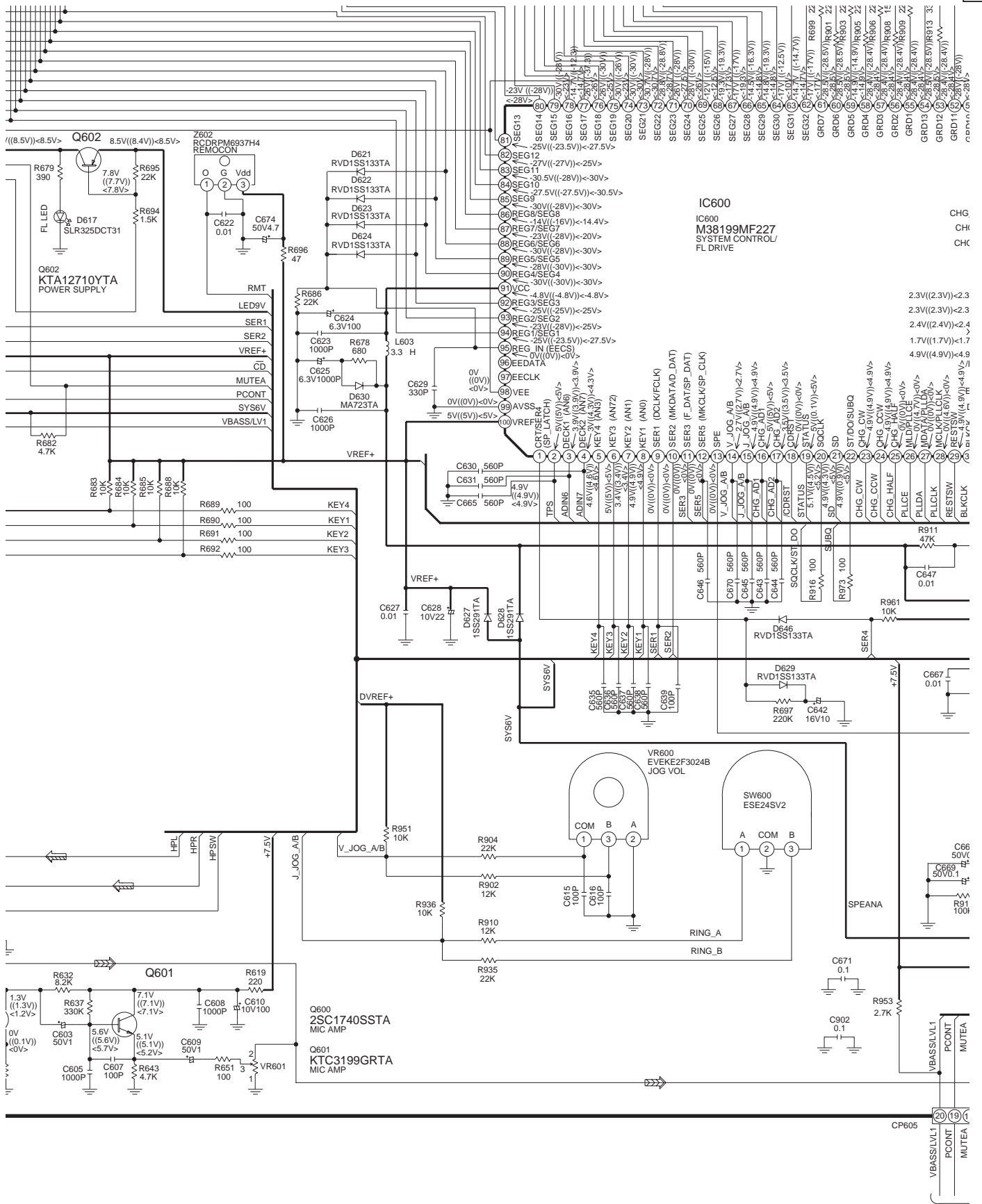

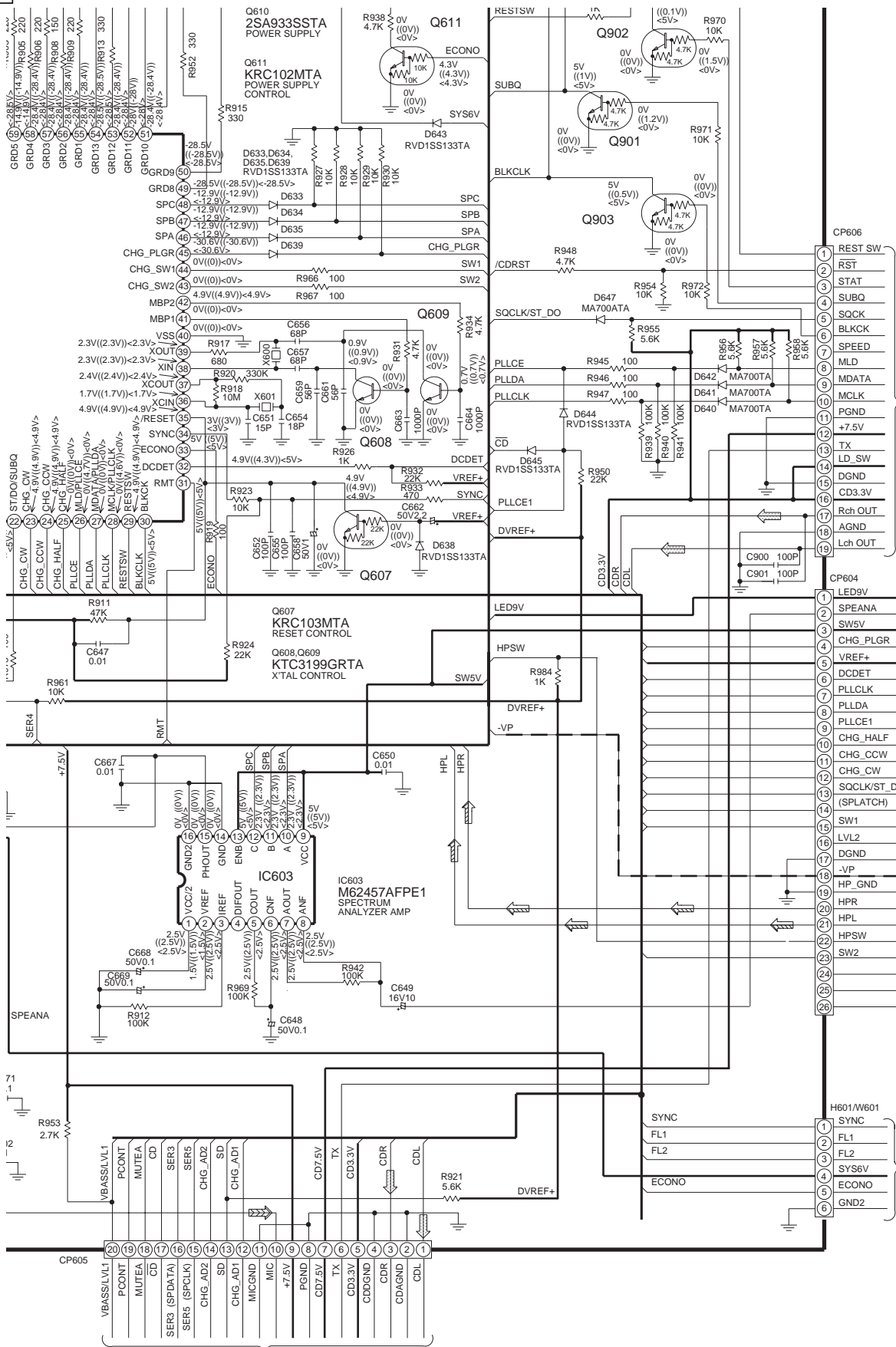

A
TO CD SERVO CIRCUIT (CN702) ON SCHEMATIC DIAGRAM-2

B
TO MAIN/TUNER CIRCUIT (CN302) ON SCHEMATIC DIAGRAM-6

M
TO AC TRANS CIRCUIT (CN502) ON SCHEMATIC DIAGRAM-14

B
TO MAIN/TUNER CIRCUIT (CN303) ON SCHEMATIC DIAGRAM-5

SCHEMATIC DIAGRAM-11

— : +B Line - - - : -B Line ⇨ : MAIN Signal Line ⇨ : CD Signal Line

P TACT SWITCH (1) CIRCUIT

C PANEL CIRCUIT (FOR GN ONLY)

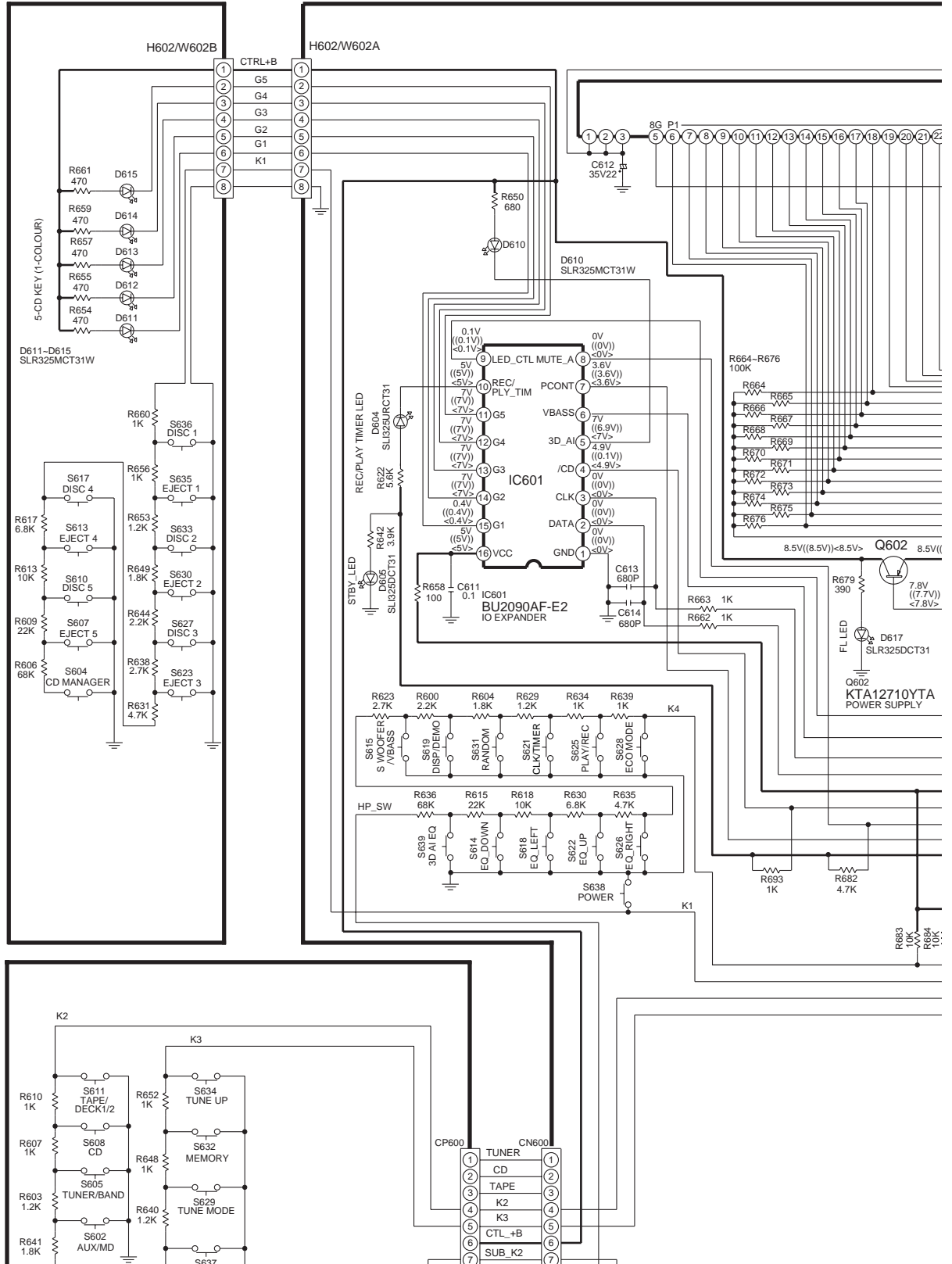

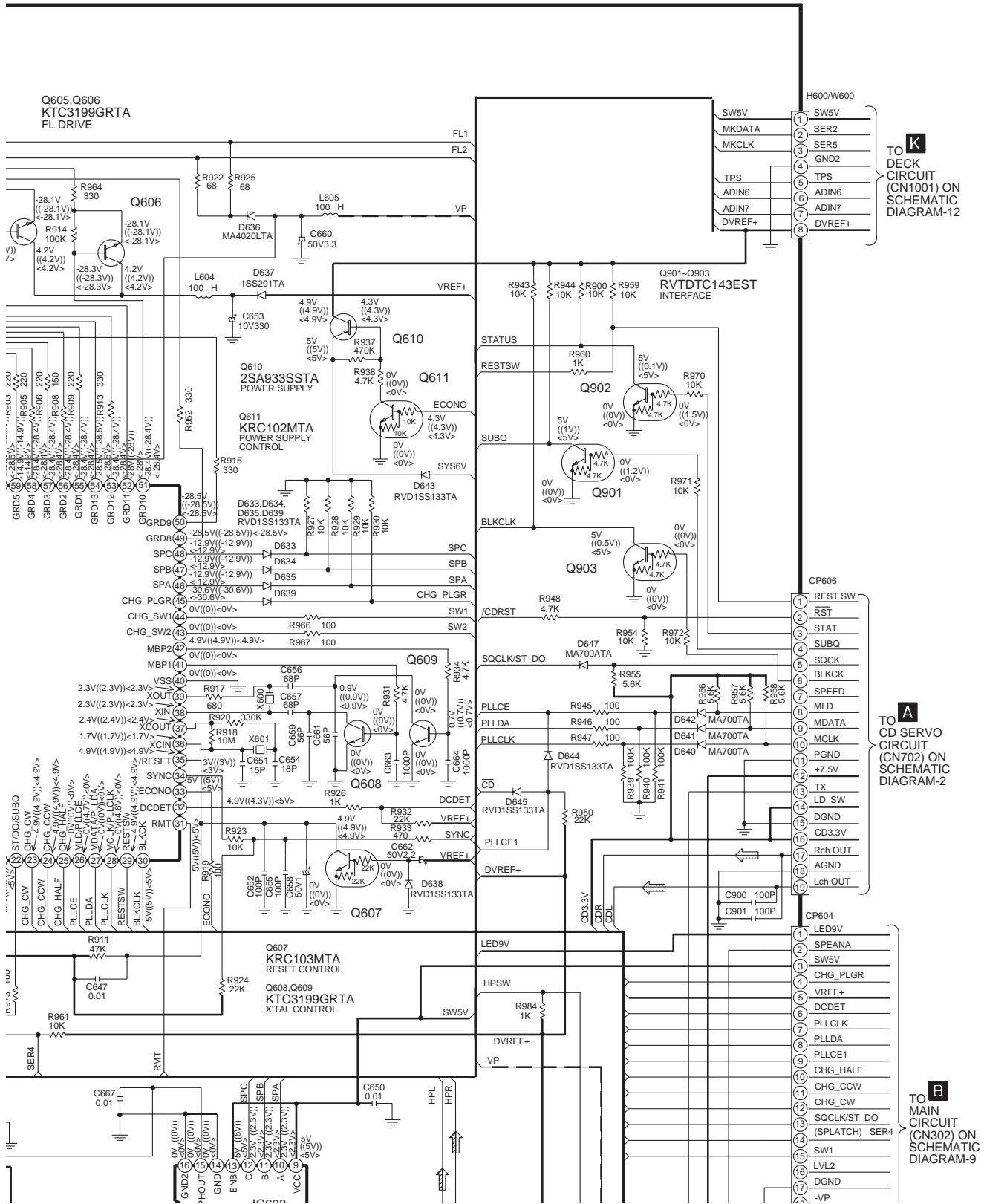

K
TO DECK CIRCUIT (CN1001) ON SCHEMATIC DIAGRAM-12

A
TO CD SERVO CIRCUIT (CN702) ON SCHEMATIC DIAGRAM-2

B
TO MAIN CIRCUIT (CN302) ON SCHEMATIC DIAGRAM-9

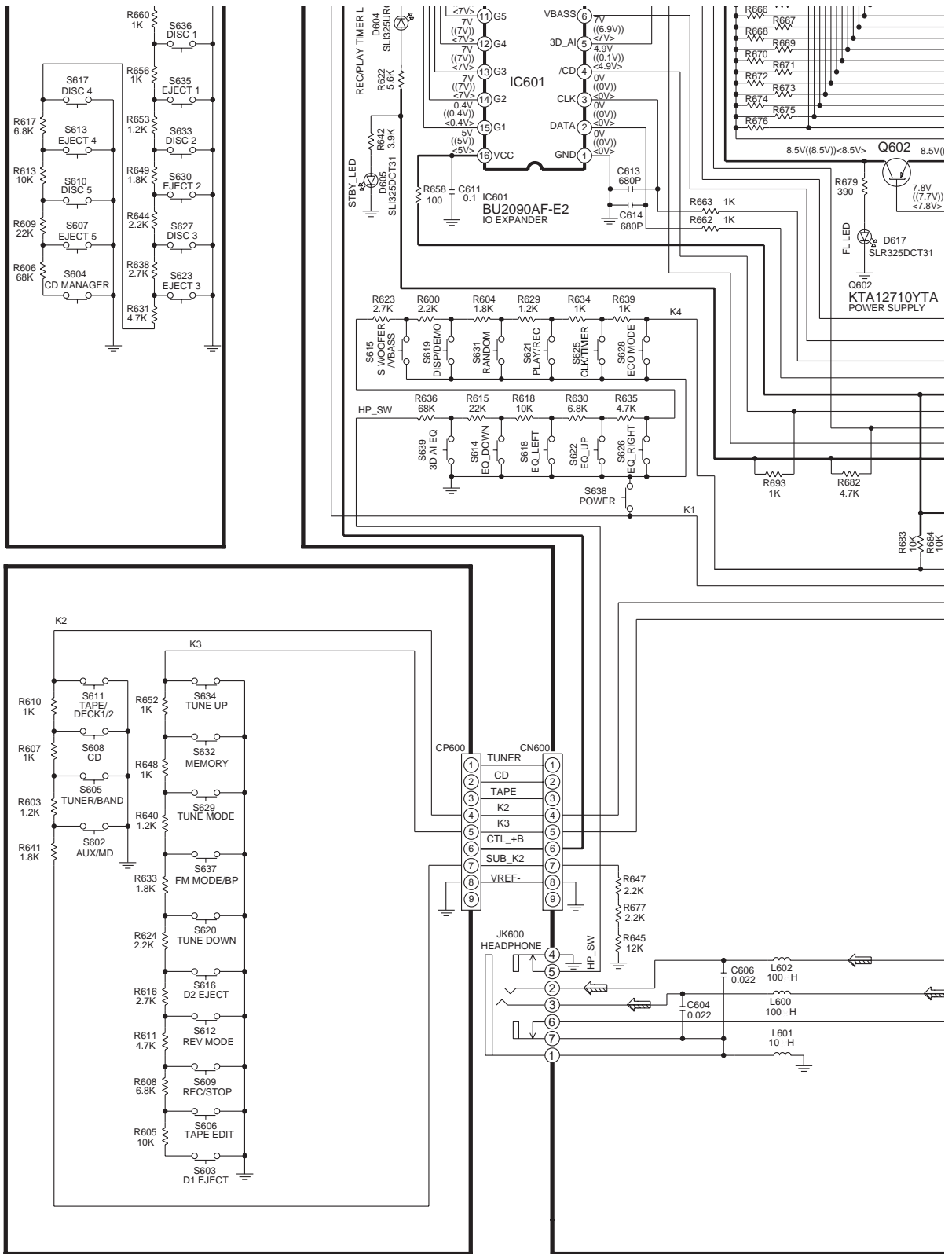

D TACT SWITCH (2) CIRCUIT

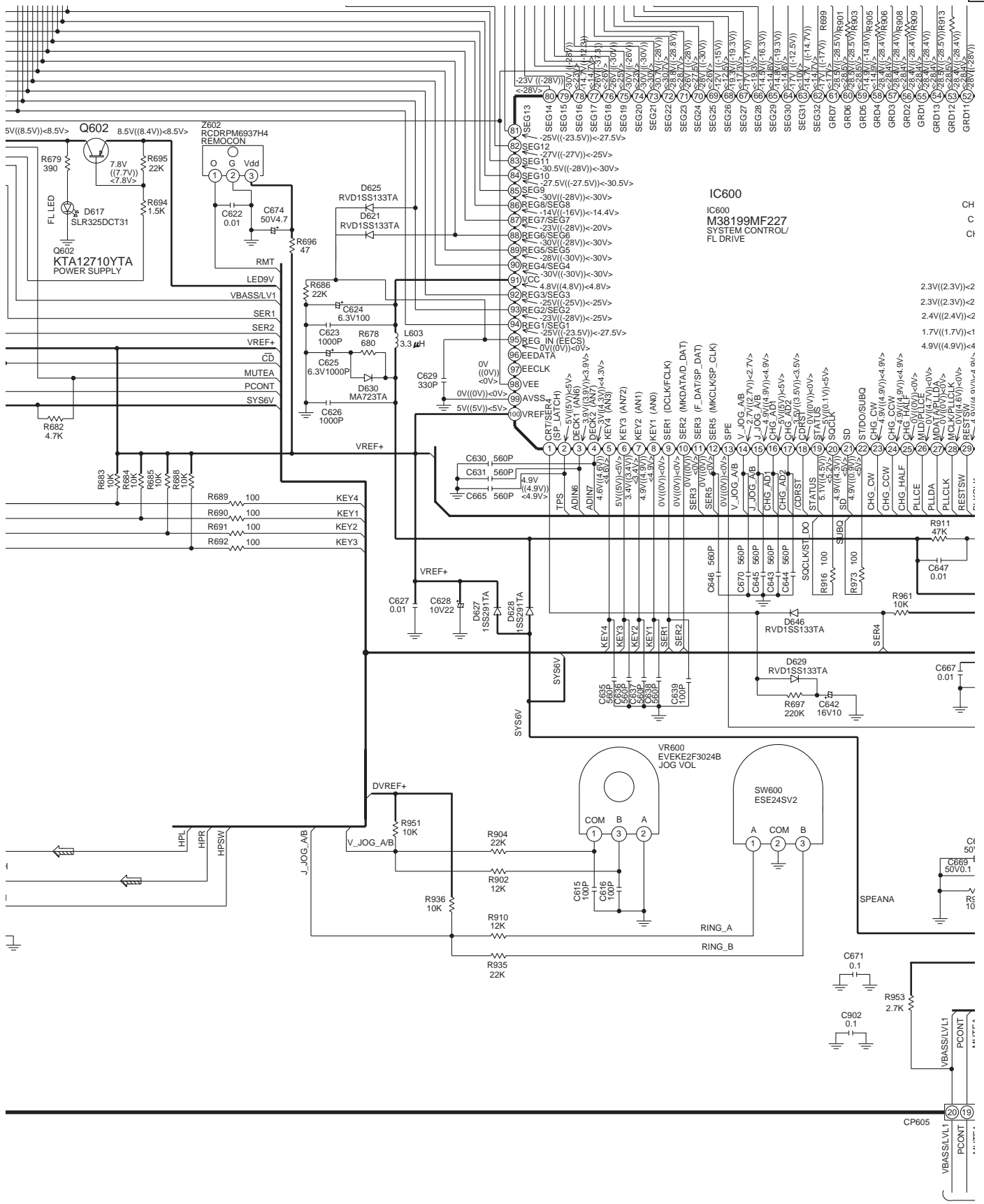

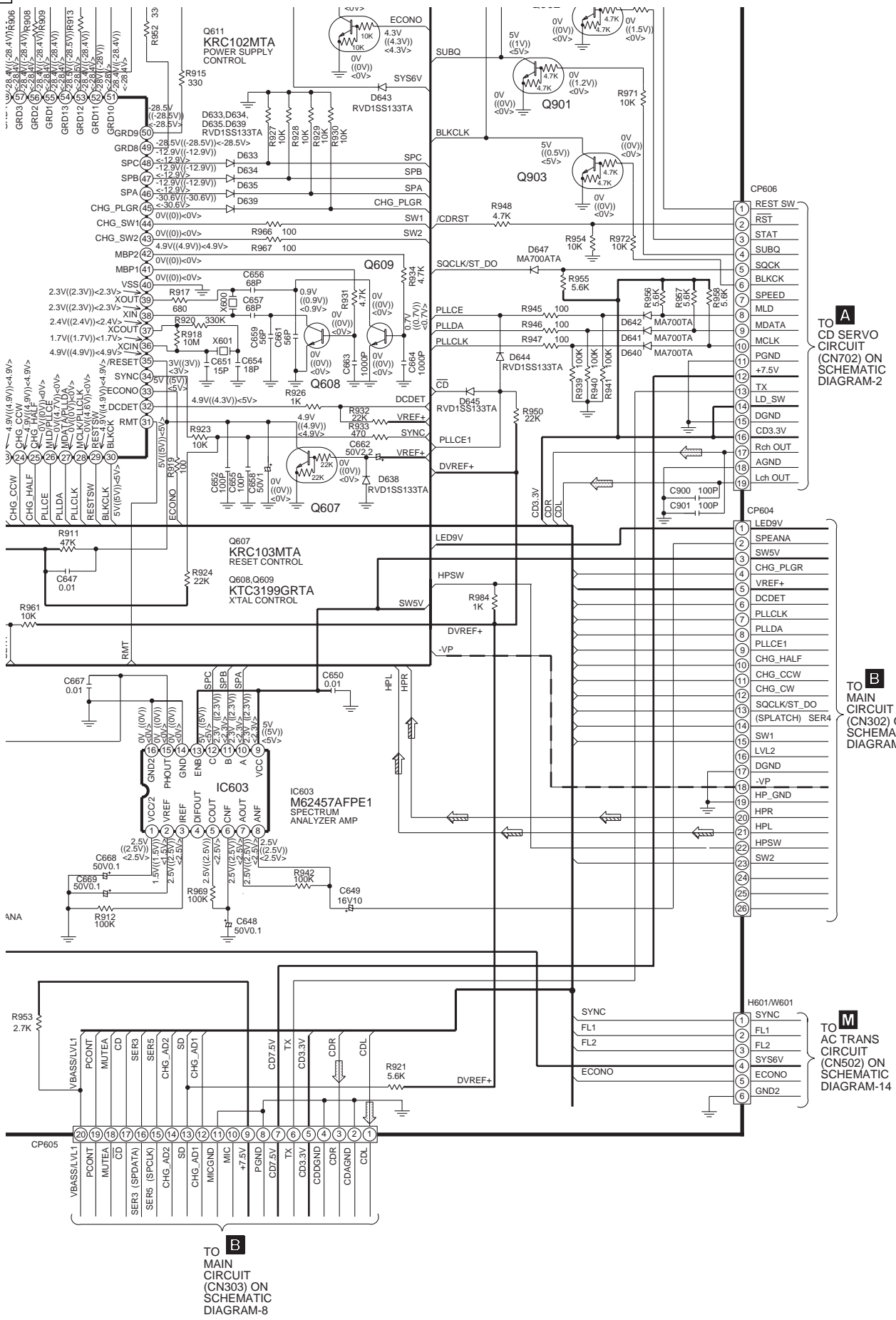

A
TO CD SERVO
CIRCUIT
(CN702) ON
SCHEMATIC
DIAGRAM-2

B
TO MAIN
CIRCUIT
(CN302) ON
SCHEMATIC
DIAGRAM-9

M
TO AC TRANS
CIRCUIT
(CN502) ON
SCHEMATIC
DIAGRAM-14

B
TO MAIN
CIRCUIT
(CN303) ON
SCHEMATIC
DIAGRAM-8

SCHMATIC DIAGRAM-12

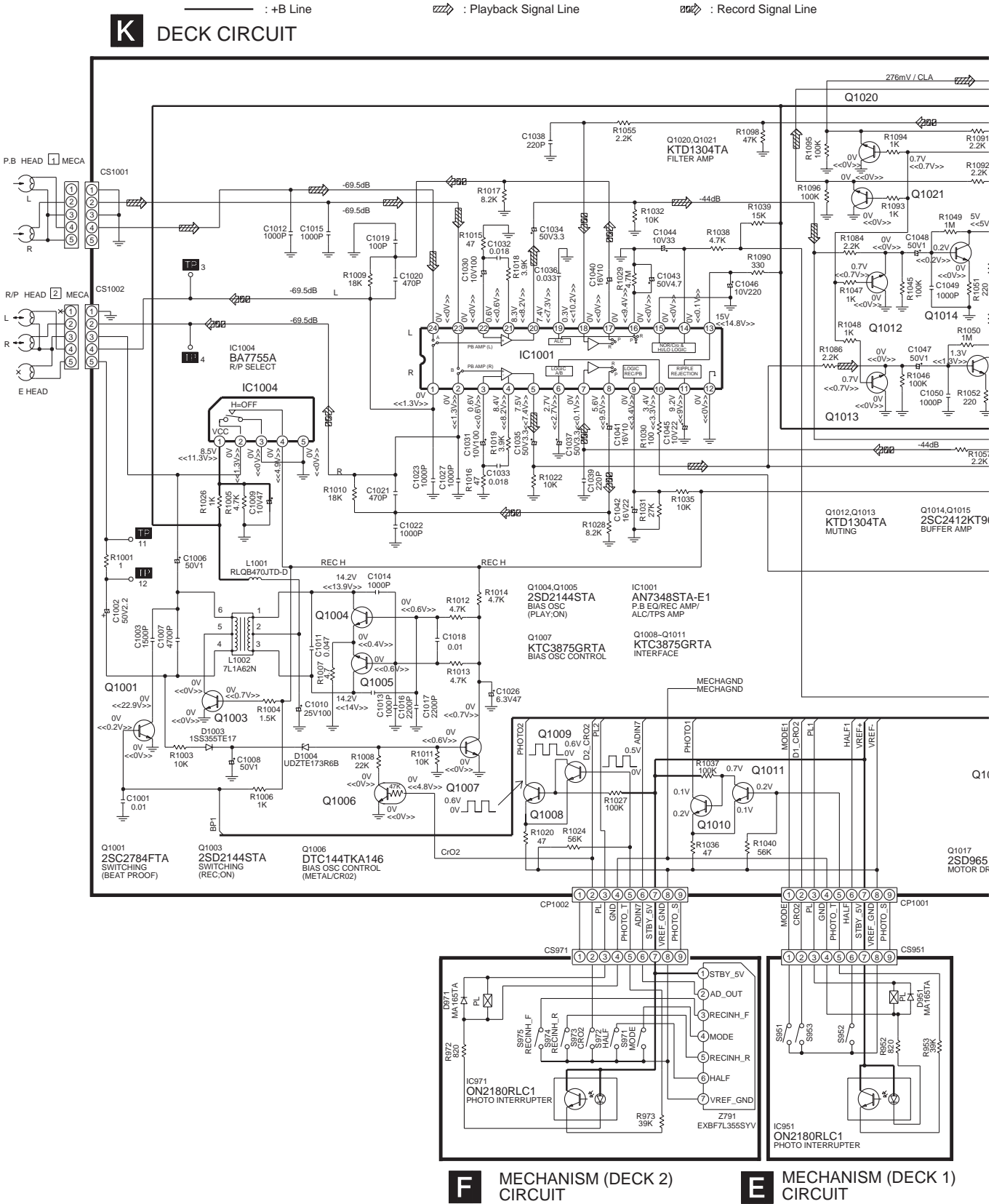

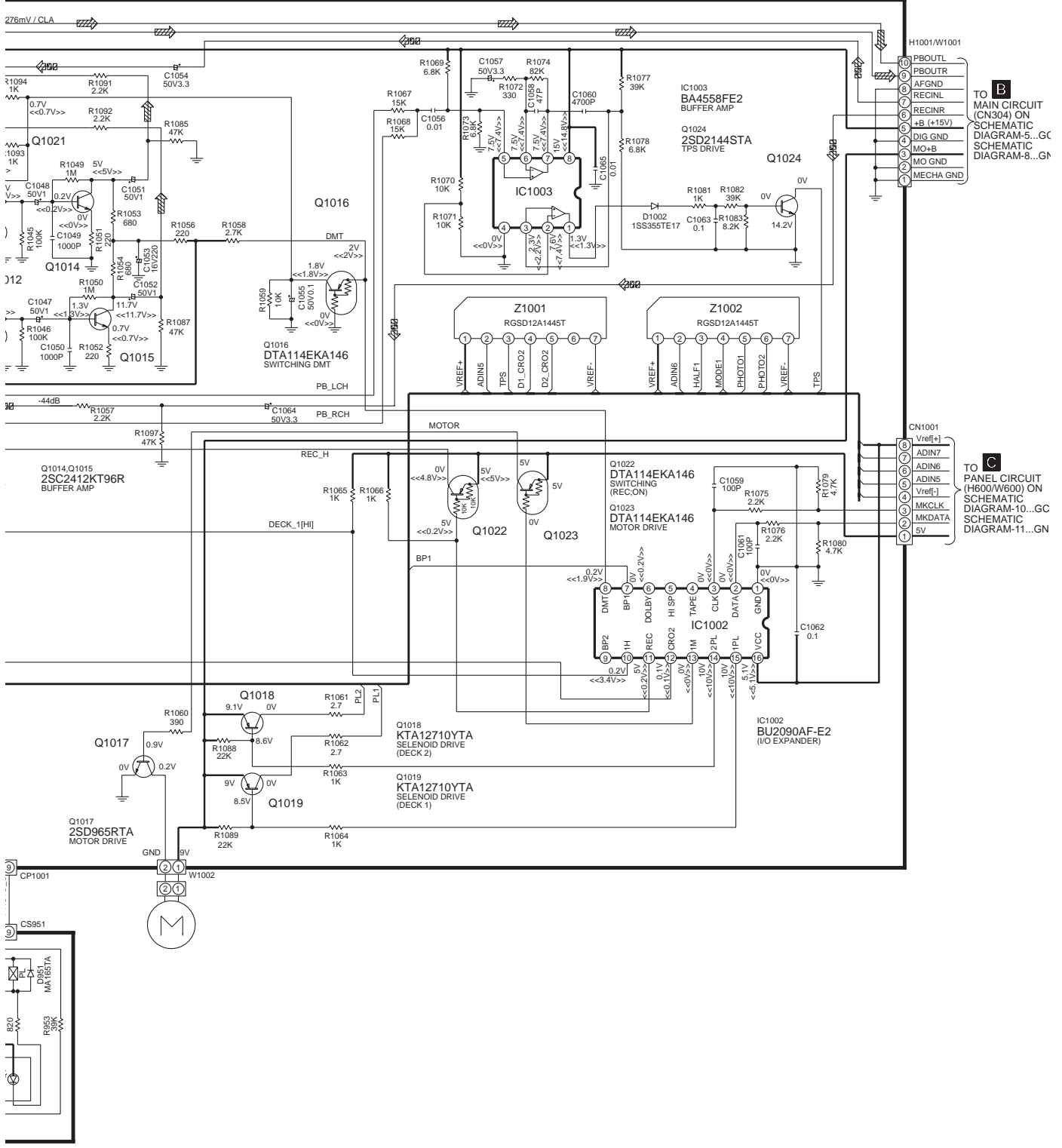

(DECK 1)

SCHEMATIC DIAGRAM-13

POWER CIRCUIT

: +B Line

: -B Line

➔ : MAIN Signal Line

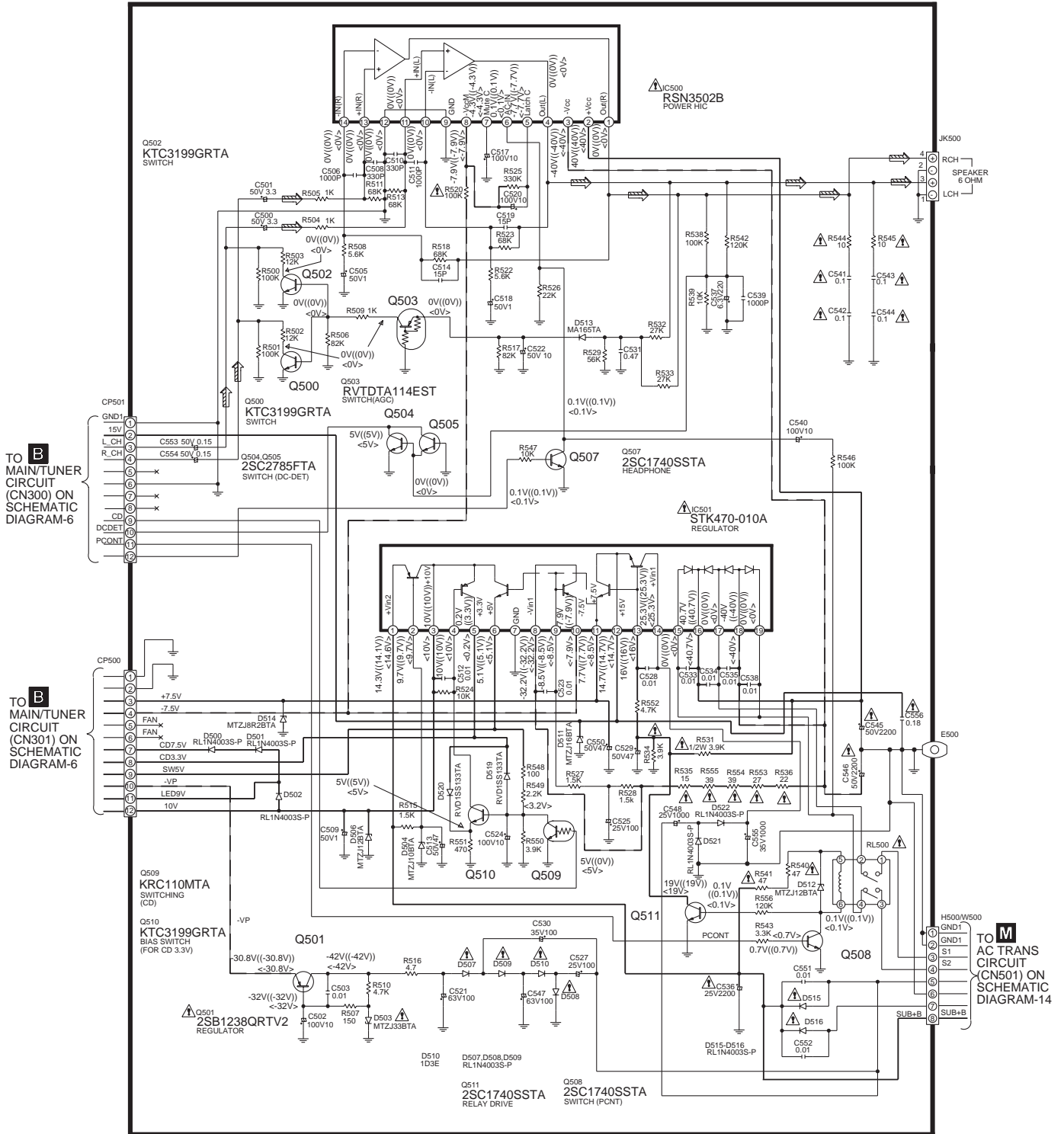

SCHMATIC DIAGRAM-14

————— : +B Line - - - - - : -B Line

M AC TRANS CIRCUIT (FOR GC ONLY)

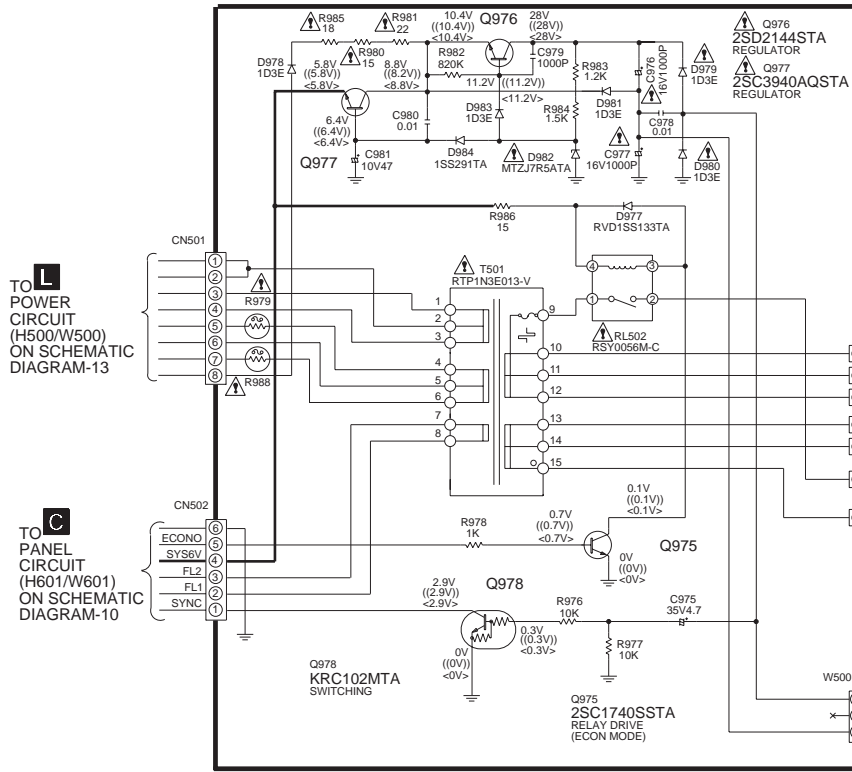

L TO POWER CIRCUIT (H500/W500) ON SCHEMATIC DIAGRAM-13

C TO PANEL CIRCUIT (H601/W601) ON SCHEMATIC DIAGRAM-10

O VOLTAGE SELECTOR CIRCUIT (FOR GC ONLY)

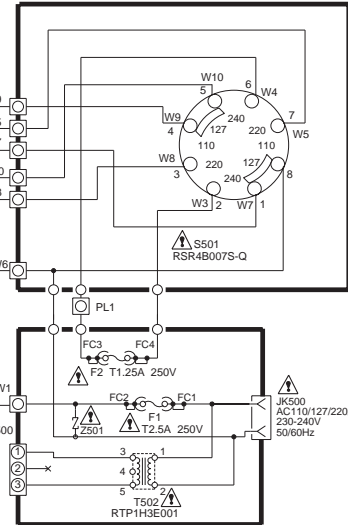

N SUB-TRANSFORMER CIRCUIT (FOR GC ONLY)

M AC TRANS CIRCUIT (FOR GN ONLY)

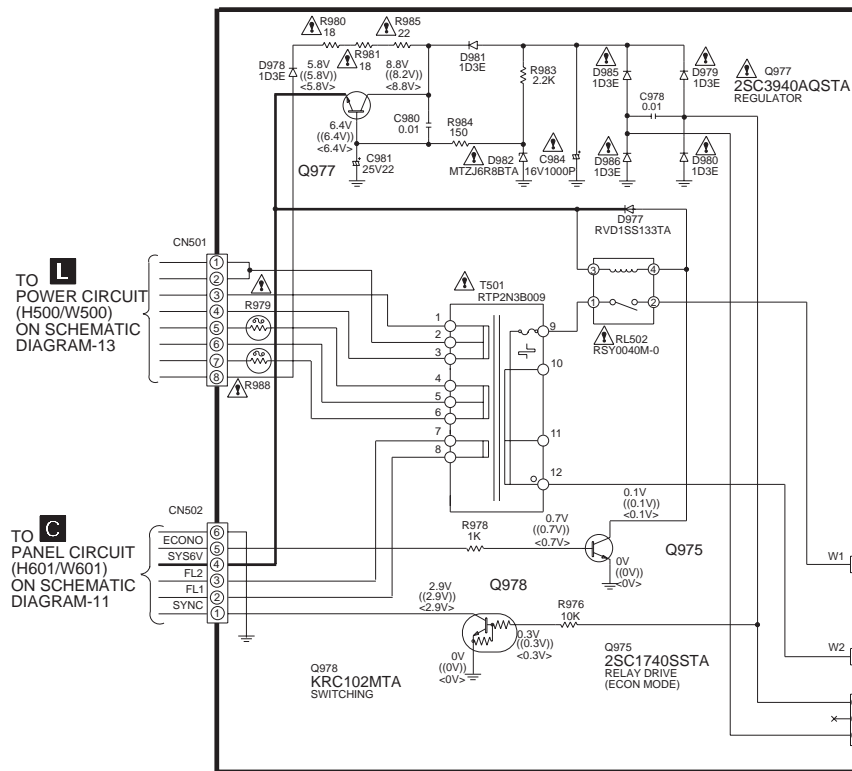

L TO POWER CIRCUIT (H500/W500) ON SCHEMATIC DIAGRAM-13

C TO PANEL CIRCUIT (H601/W601) ON SCHEMATIC DIAGRAM-11

N SUB-TRANSFORMER CIRCUIT (FOR GN ONLY)

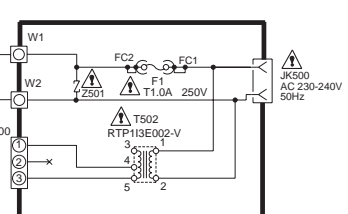

SCHMATIC DIAGRAM-15

— : +B Line

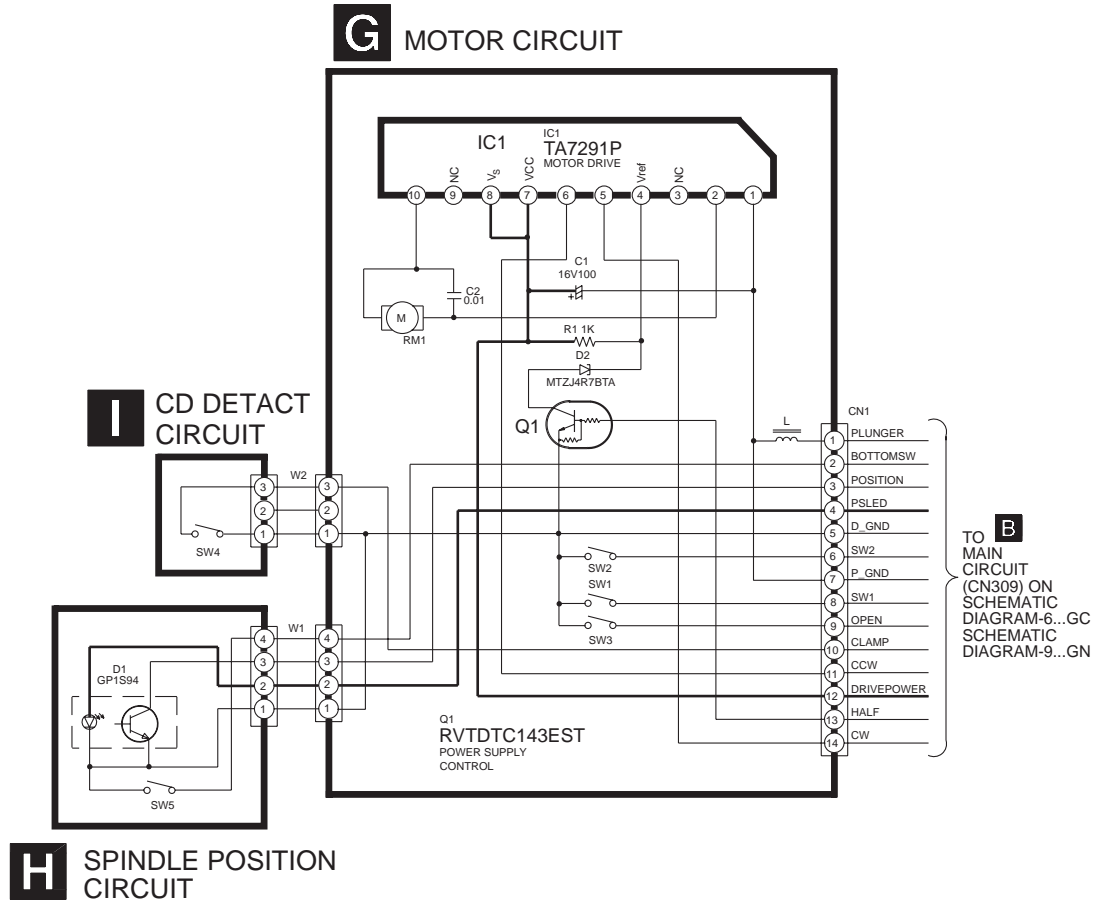

16 Printed Circuit Board

Note: Circuit board diagrams may be modified at any time with the development of new technology.

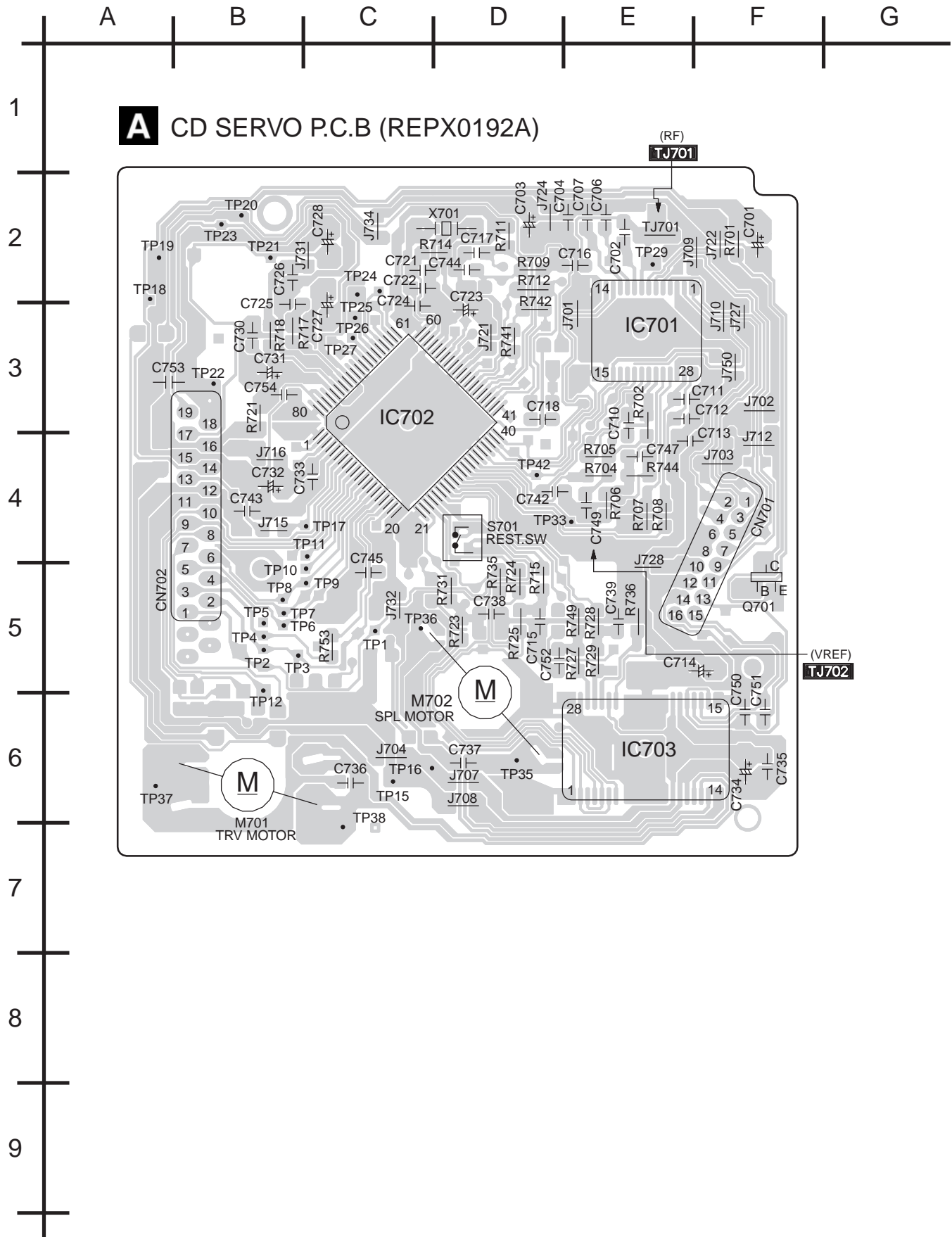

A B C D E F G

1
2
3
4
5
6
7
8
9

B MAIN / TUNER P.C.B (REPX0199B)

FM ANT MW ANT SW ANT AUX

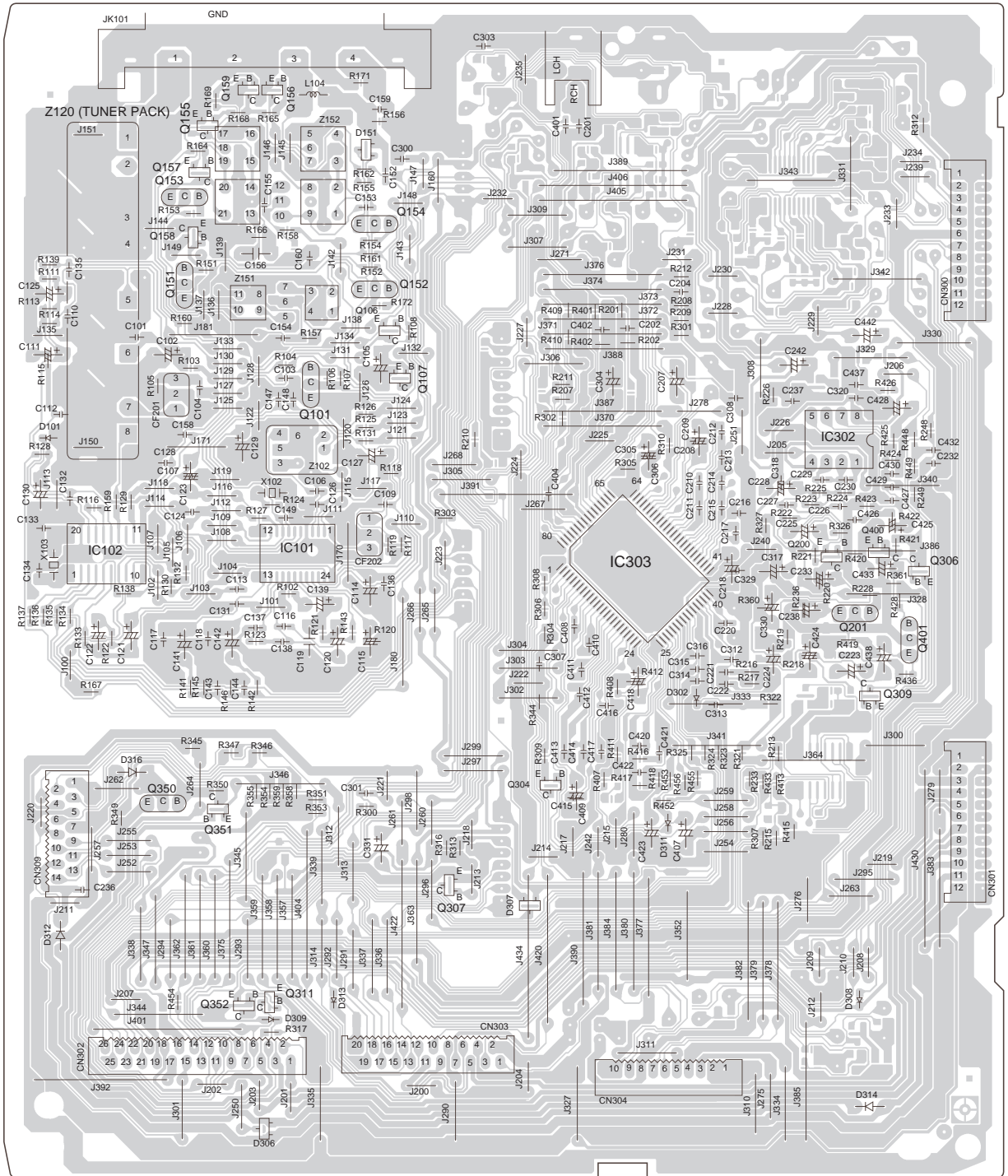

A B C D E F G

1
2
3
4
5
6
7
8
9

B MAIN P.C.B (REPX0200C...GN)

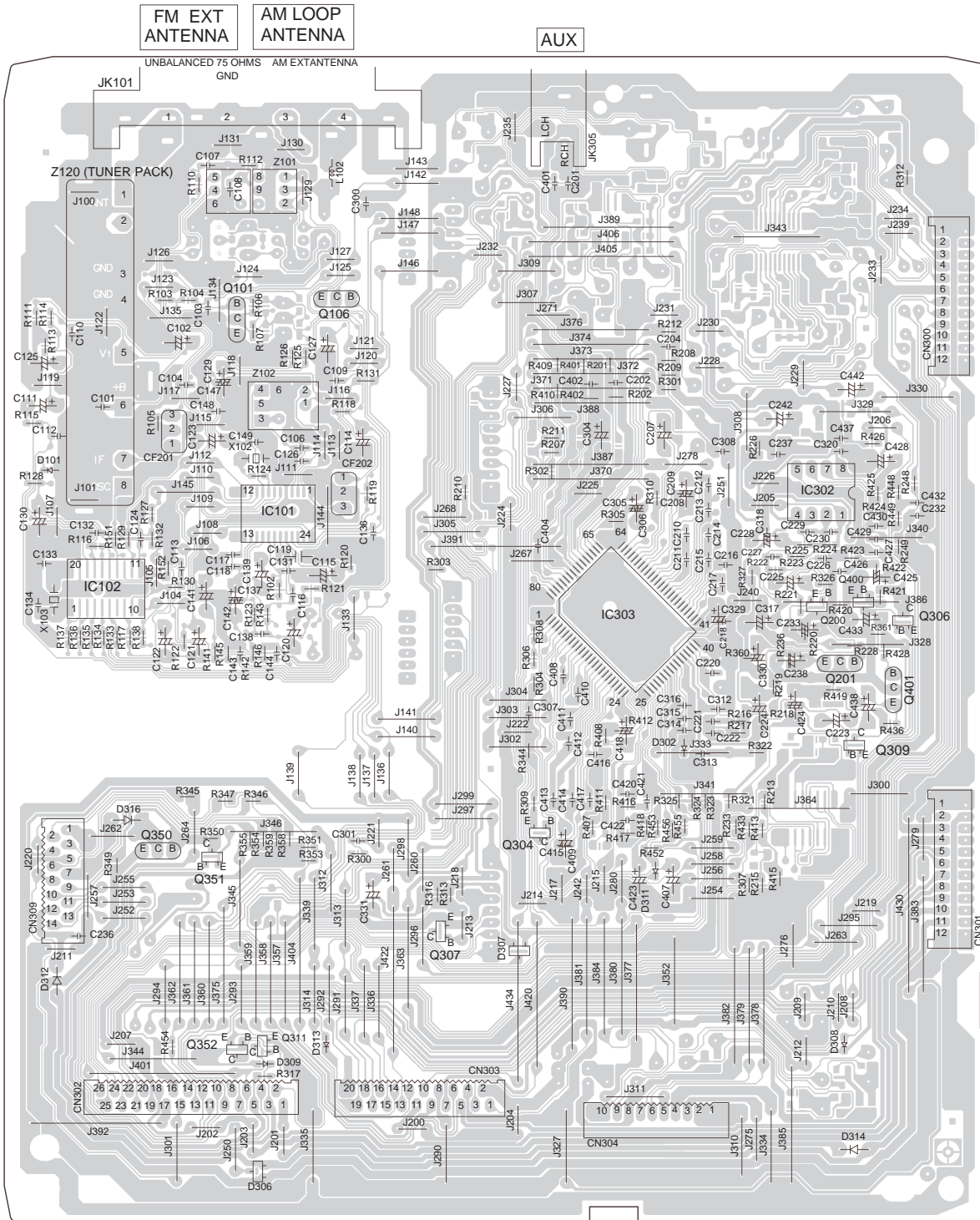

A B C D E F G

1
2
3
4
5
6
7
8
9

C PANEL P.C.B (REPX0197E...GC)

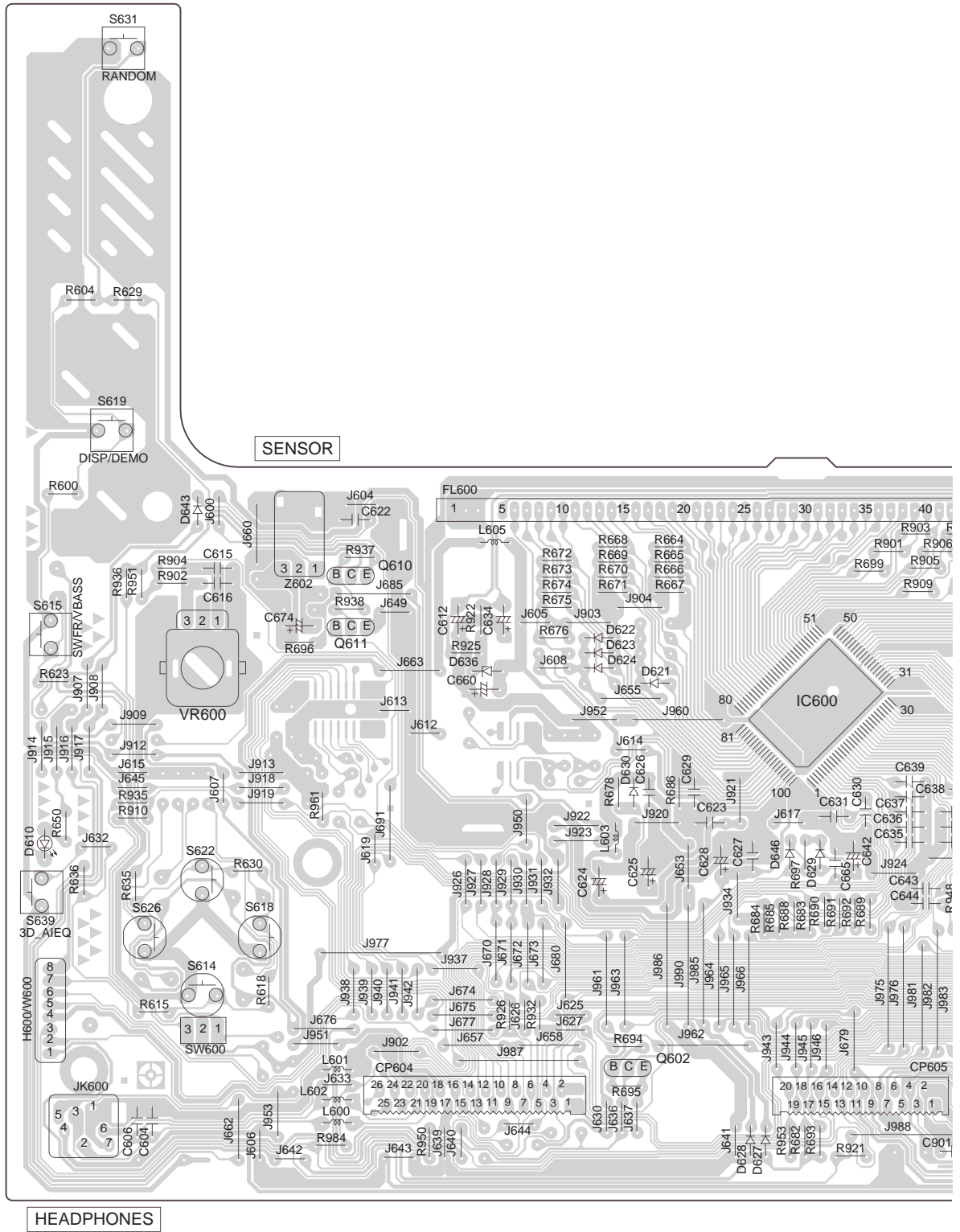

G | H | I | J | K | L | M

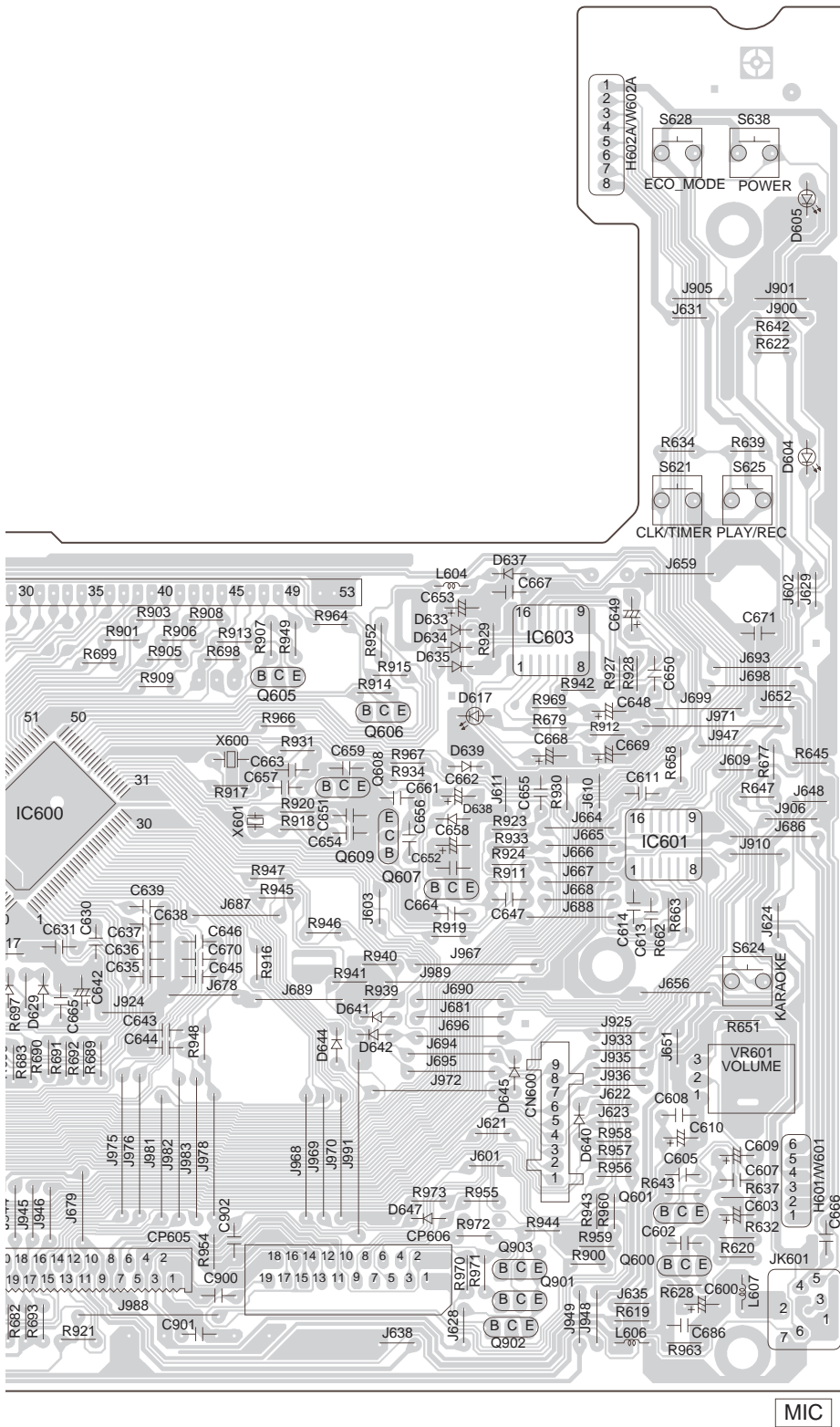

Ref. No.	Loc. No.	Ref. No.	Loc. No.
D604	K4	Q602	E8
D605	K2	Q605	H5
D610	A7	Q606	I5
D617	I5	Q607	I6
D627	F9	Q608	H6
D628	F9	Q609	H6
D629	G7	Q610	D5
D633	I5	Q611	D5
D634	I5	Q901	I9
D635	I5	Q902	I9
D636	D6	Q903	I8
D637	I4	X600	H5
D638	I6	X601	H6
D639	I5	Z602	C5
D641	H7		
D642	H7		
D643	B4		
D644	H7		
D646	G7		
IC600	G6		
IC601	J6		
IC603	I5		
JK600	B9		
L600	C9		
L601	C8		
L602	C8		
L603	E7		
L604	I4		

G | H | I | J | K | L | M

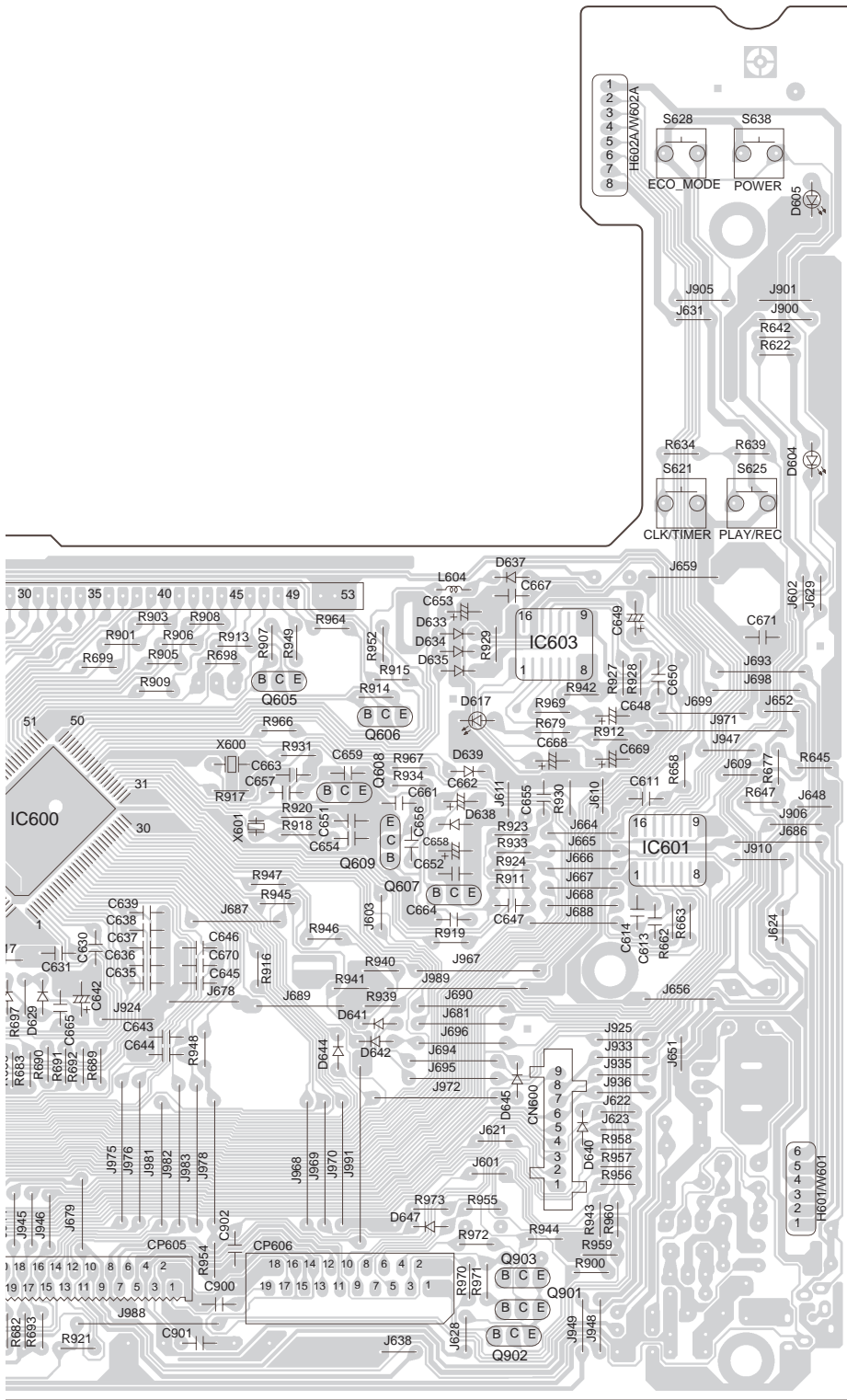

Ref. No.	Loc. No.	Ref.No.	Loc.No.
D604	K4	Q602	E8
D605	K2	Q605	H5
D610	A7	Q606	I5
D617	I5	Q607	I6
D627	F9	Q608	H6
D628	F9	Q609	H6
D629	G7	Q610	D5
D633	I5	Q611	D5
D634	I5	Q901	I9
D635	I5	Q902	I9
D636	D6	Q903	I8
D637	I4	X600	H5
D638	I6	X601	H6
D639	I5	Z602	C5
D641	H7		
D642	H7		
D643	B4		
D644	H7		
D646	G7		
IC600	G6		
IC601	J6		
IC603	I5		
JK600	B9		
L600	C9		
L601	C8		
L602	C8		
L603	E7		
L604	I4		

A B C D E F G

1 **E** MECHANISM (DECK 1) P.C.B. (REPX0108A)

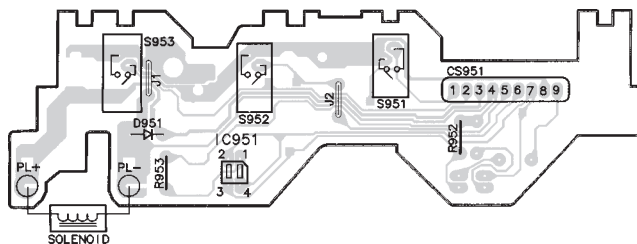

3 **F** MECHANISM (DECK 2) P.C.B. (REPX0108)

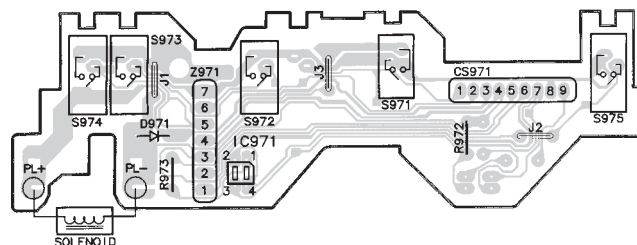

5 **G** MOTOR P.C.B. (REP2578A-N)

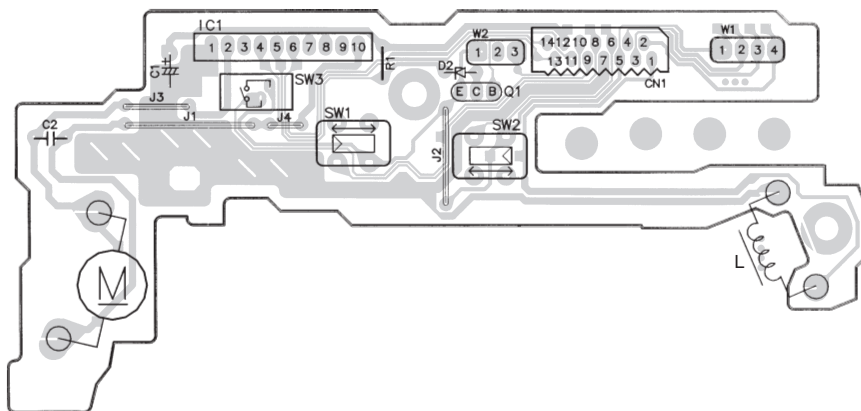

7 **H** SPINDLE POSITION P.C.B. (REP2578A-N)

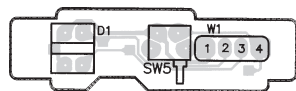

7 **J** TUNER PACK P.C.B. (REP1999B)

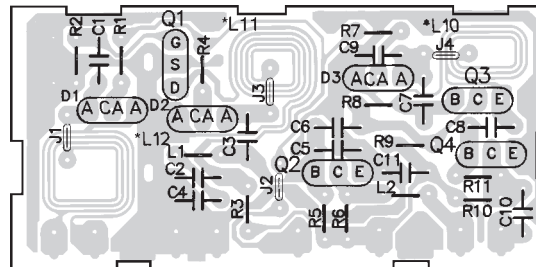

8 **I** CD DETACT P.C.B. (REP2578A-N)

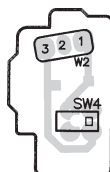

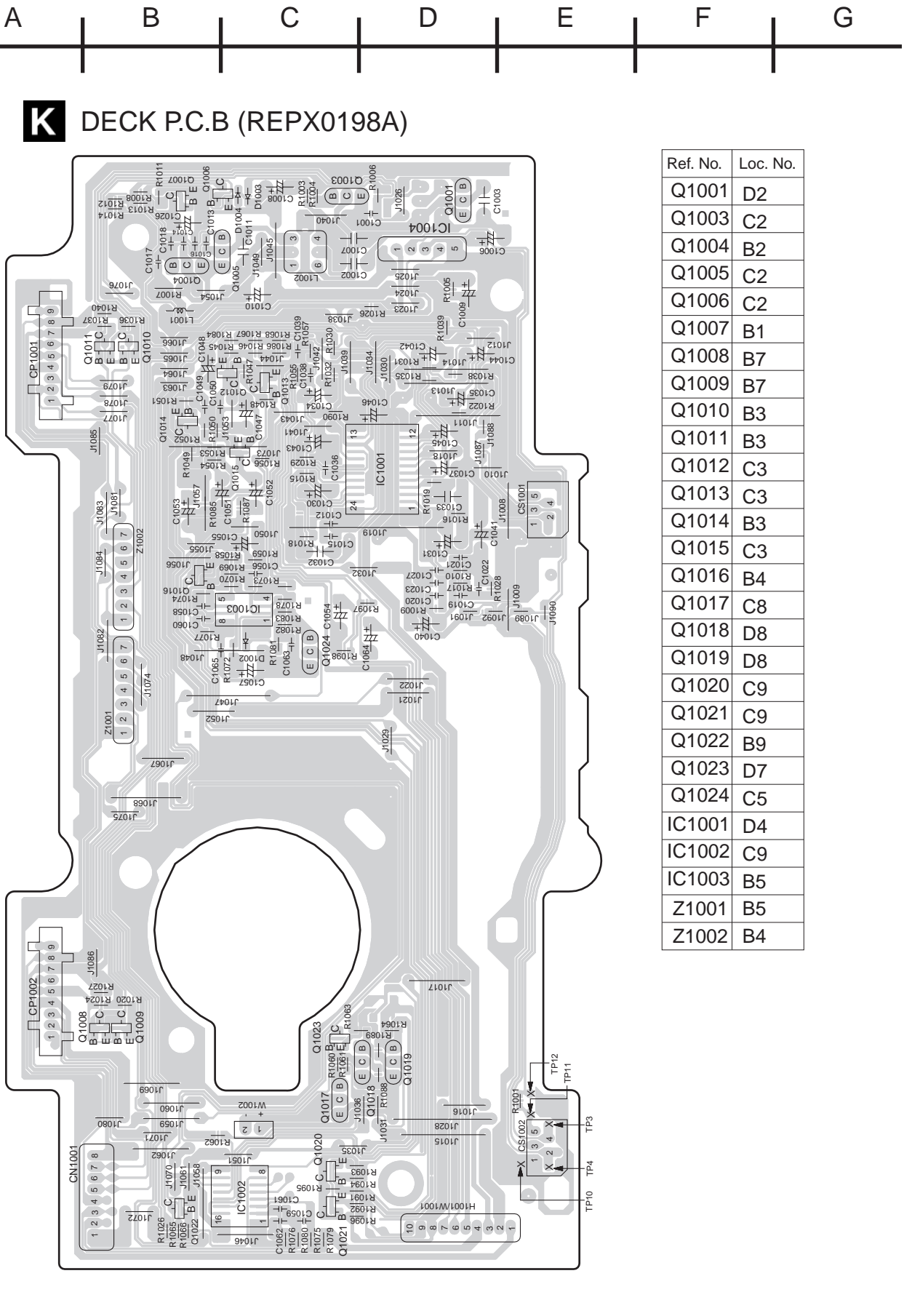

K DECK P.C.B (REPX0198A)

Ref. No.	Loc. No.
Q1001	D2
Q1003	C2
Q1004	B2
Q1005	C2
Q1006	C2
Q1007	B1
Q1008	B7
Q1009	B7
Q1010	B3
Q1011	B3
Q1012	C3
Q1013	C3
Q1014	B3
Q1015	C3
Q1016	B4
Q1017	C8
Q1018	D8
Q1019	D8
Q1020	C9
Q1021	C9
Q1022	B9
Q1023	D7
Q1024	C5
IC1001	D4
IC1002	C9
IC1003	B5
Z1001	B5
Z1002	B4

A | B | C | D | E | F | G

1
2
3
4
5
6
7
8
9

L POWER P.C.B (REPX0204A...GC/GN)

SPEAKERS

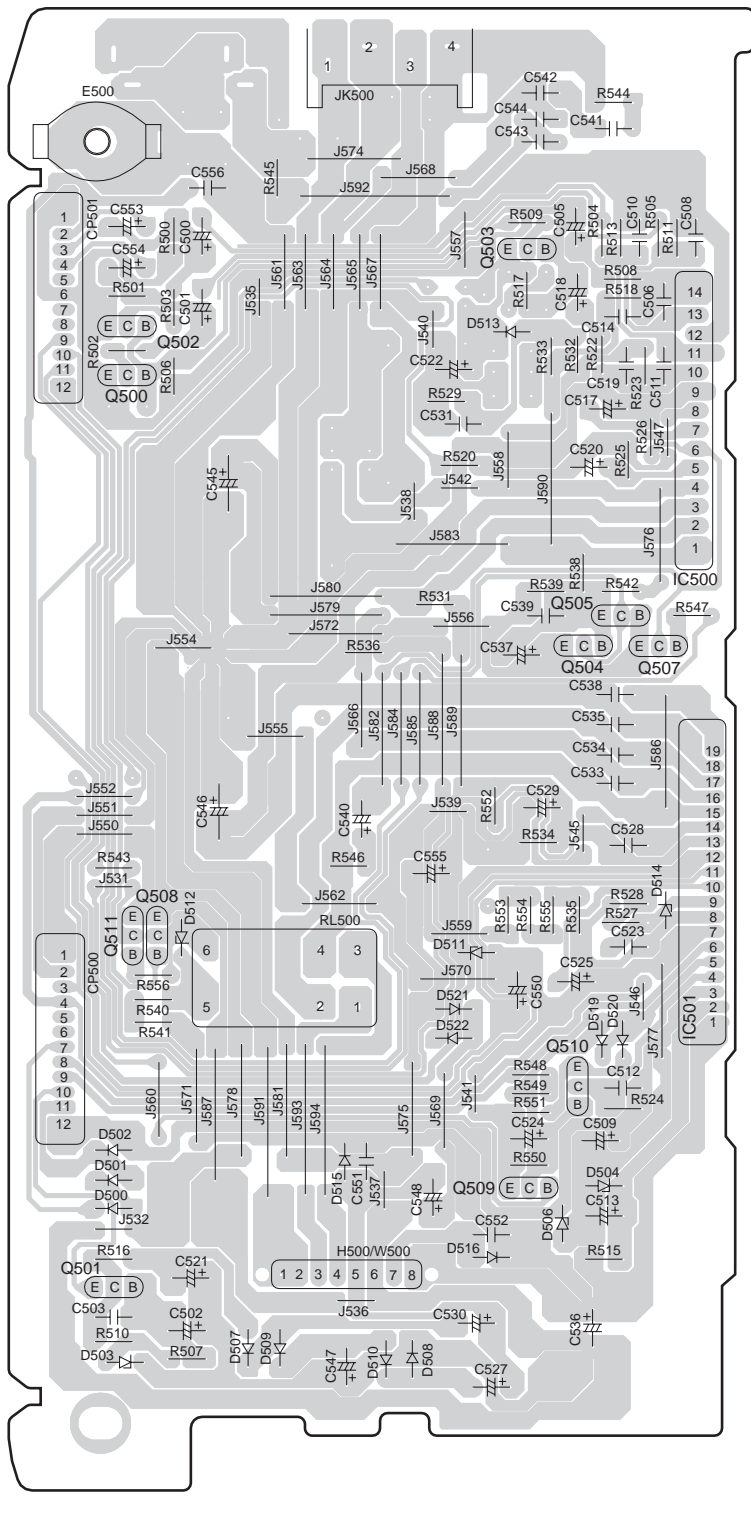

Ref. No.	Loc. No.	Ref. No.	Loc. No.
D500	B8	Q509	D8
D501	B8	Q510	D7
D502	B8	Q511	B7
D503	B9	CP500	A7
D504	D8	CP501	A3
D506	D8	RL500	C7
D507	C9	IC500	E4
D508	C9	IC501	E6
D509	C9		
D510	C9		
D511	D7		
D512	B7		
D513	D3		
D514	E6		
D515	C8		
D516	D8		
D519	D7		
D520	D7		
D521	D7		
D522	D7		
Q500	B4		
Q501	B8		
Q502	B3		
Q503	D3		
Q504	D5		
Q505	D5		
Q507	E5		
Q508	B7		

A | B | C | D | E | F | G

1 **M** AC TRANS (REPX0202B...GC)

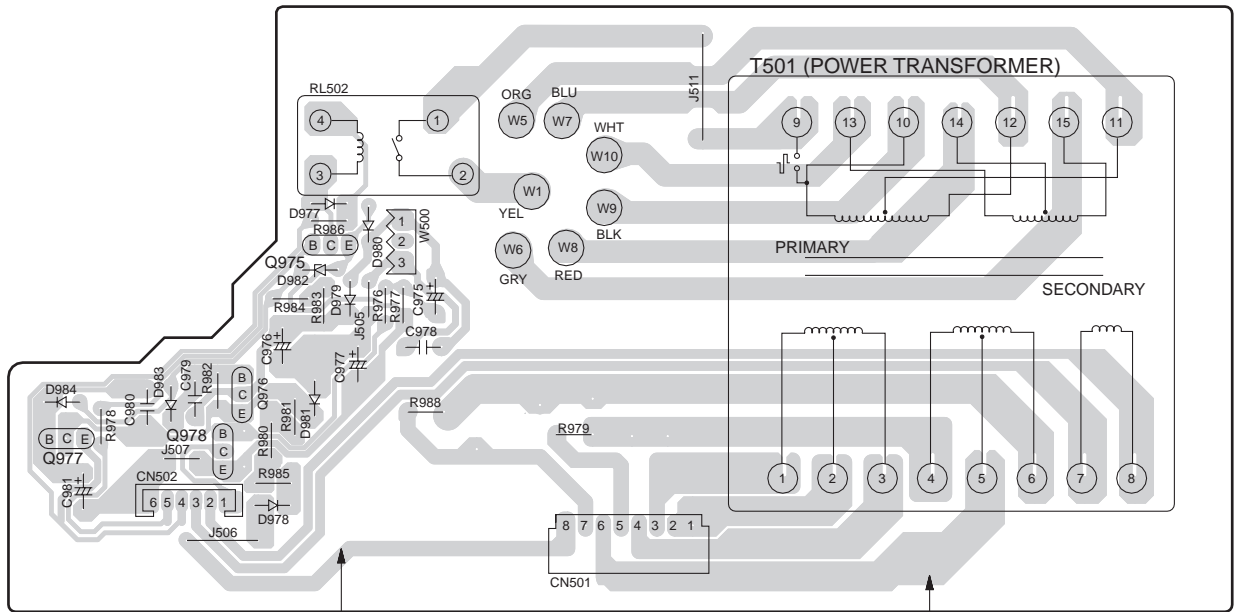

CAUTION
RISK OF ELECTRIC SHOCK
AC VOLTAGE LINE. PLEASE DO NOT
TOUCH THIS PCB.

6 **O** VOLTAGE SELECTOR P.C.B (REPX0202B...GC)

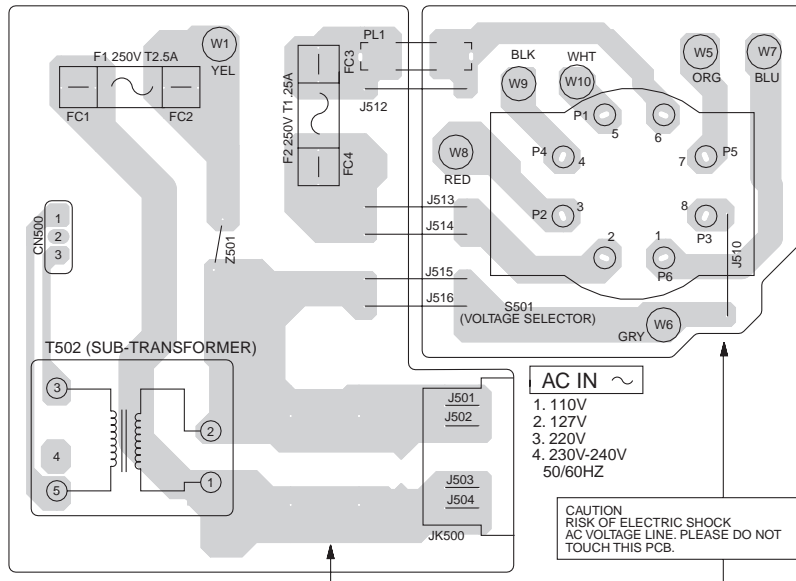

AC IN ~
1. 110V
2. 127V
3. 220V
4. 230V-240V
50/60HZ
CAUTION
RISK OF ELECTRIC SHOCK
AC VOLTAGE LINE. PLEASE DO NOT
TOUCH THIS PCB.

9 **N** SUB-TRANSFORMER P.C.B (REPX0202B...GC)

A B C D E F G

1
2
3
4
5
6
7
8
9

M AC TRANS P.C.B (REPX0203F...GN)

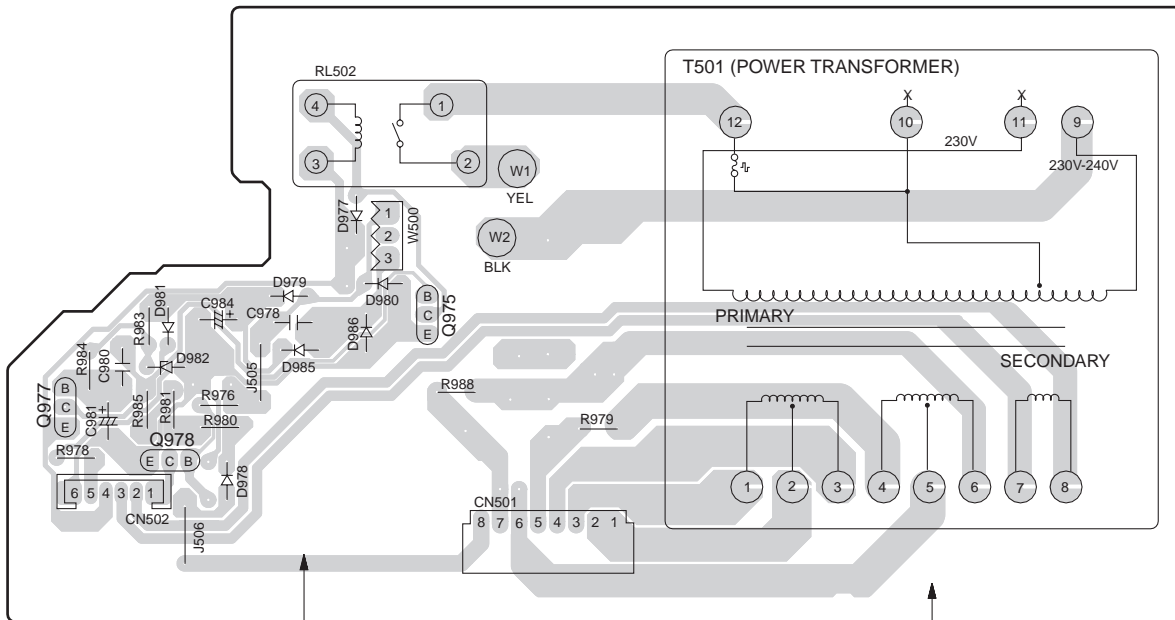

CAUTION
RISK OF ELECTRIC SHOCK
AC VOLTAGE LINE. PLEASE DO NOT
TOUCH THIS PCB.

N SUB-TRANSFORMER P.C.B (REPX0203F...GN)

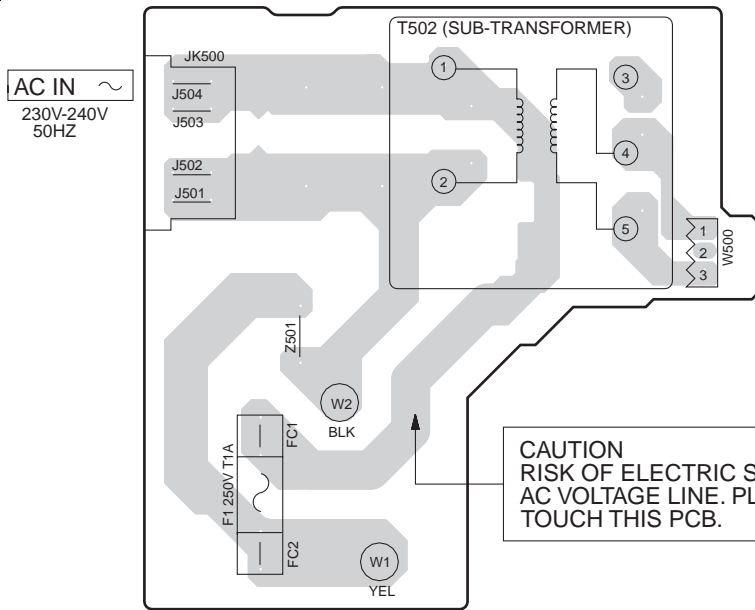

CAUTION
RISK OF ELECTRIC SHOCK
AC VOLTAGE LINE. PLEASE DO NOT
TOUCH THIS PCB.

17 Wiring Connection Diagram

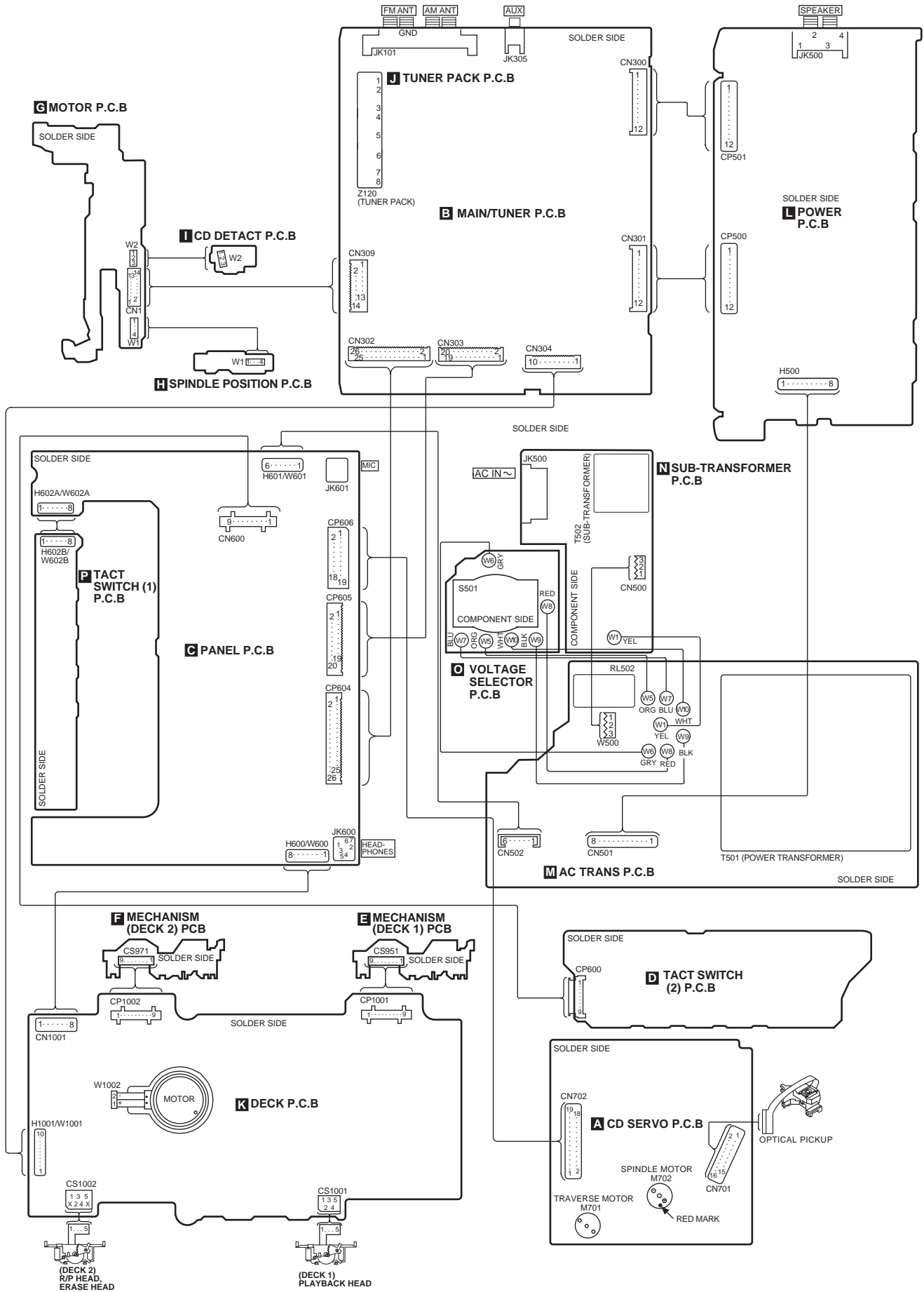

19 Parts Location and Replacement Parts List

Notes:

- Important safety notice:

Components identified by \triangle mark have special characteristics important for safety.

Furthermore, special parts which have purposes of fire-retardent (resistors), high-quality sound (capacitors), low noise (resistors), etc are used.

When replacing any of these components, be sure to use only manufacturer's specified parts shown in the parts list.

- The parenthesized indications in the Remarks columns specify the areas or colour. (Refer to teh cover page for area or colour)

Parts without these indications can be used for all areas.

- Warning: This product uses a laser diode. Refer to caution statements on page 3.

ACHTUNG:

– Die Lasereinheit nicht zerlegen.

– Die Lasereinheit darf nur gegen eine vom Hersteller spezifizierte Einheit ausgetauscht werden.

- Capacitor values are in microfarads (μF) unless specified otherwise, P= Pico-farads (pF), F= Farads.
- Resistance values are in ohms, unless specified otherwise, 1K=1,000 (OHM).
- The marking (RTL) indicates that the Retention Time is limited for this items. After the discontinuation of this assembly in production, the item will continue to be available for a specific period of time. The retention period of a availability is dependent on the type of assembly, and in accordance with the laws governing part and product retention. After the end of this period, the assembly will no longer be available.
- [M] Indicates in the Remarks columns indicates parts supplied by **MESA**.
- The "(SF)" mark denotes the standard part.
- Remote Control Unit: Supply period for three years from terminal of production.
- Reference for O/I book languages are as follows:

Ar :	Arabic	Du :	Dutch	It :	Italian	Sp :	Spanish
Cf :	Canadian French	En :	English	Ko :	Korean	Sw :	Swedish
Cz :	Czech	Fr :	French	Po :	Polish	Co :	Traditional Chinese
Da :	Danish	Ge :	German	Ru :	Russian	Cn :	Simplified Chinese

19.1. Deck Mechanism (RAA3410-S)

19.1.1. Deck Mechanism Parts Location

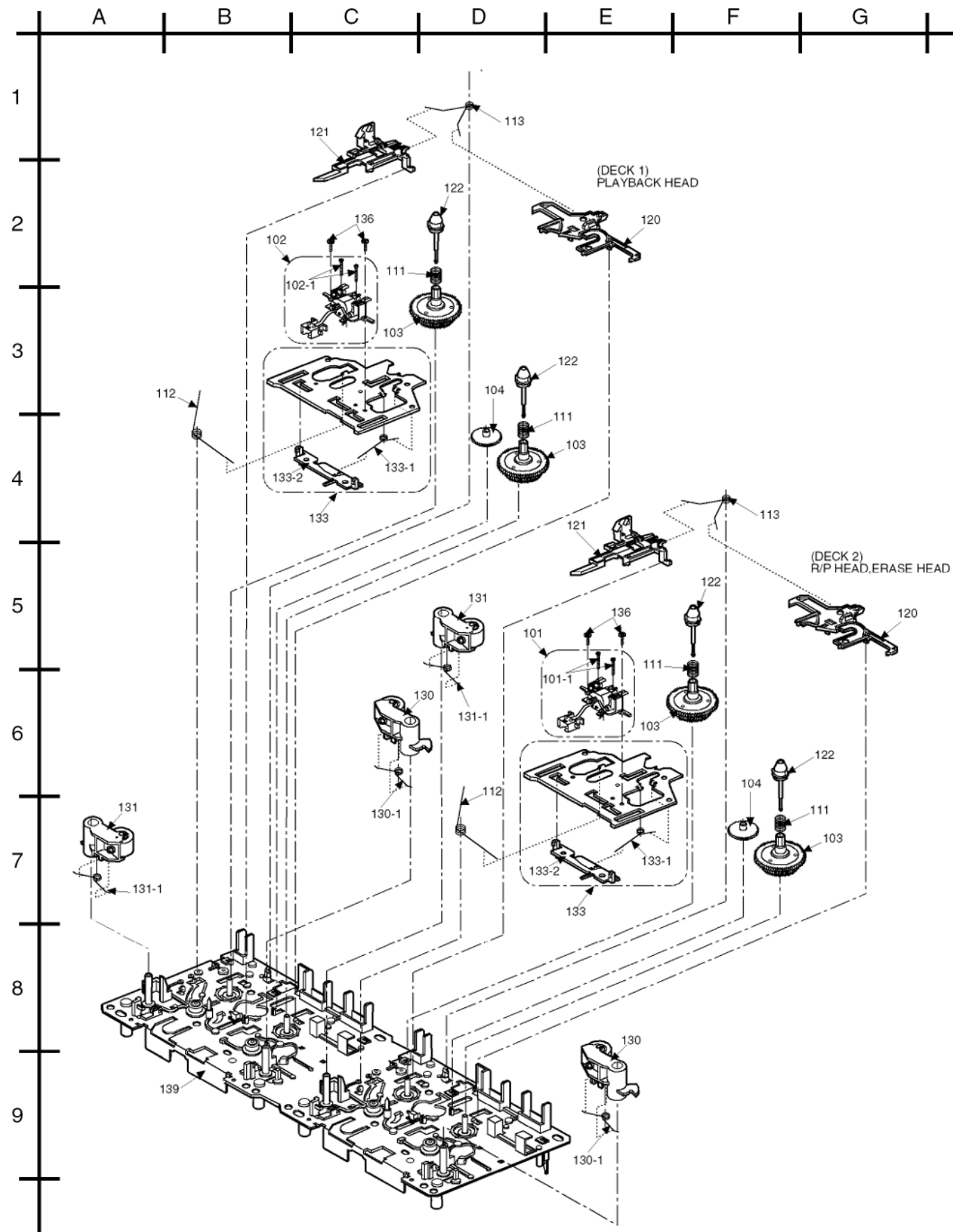

SPECIFICATIONS

Playback torque	20 ~ 60 g·cm
Fast forward torque	60 ~ 160 g·cm
Rewind torque	60 ~ 160 g·cm

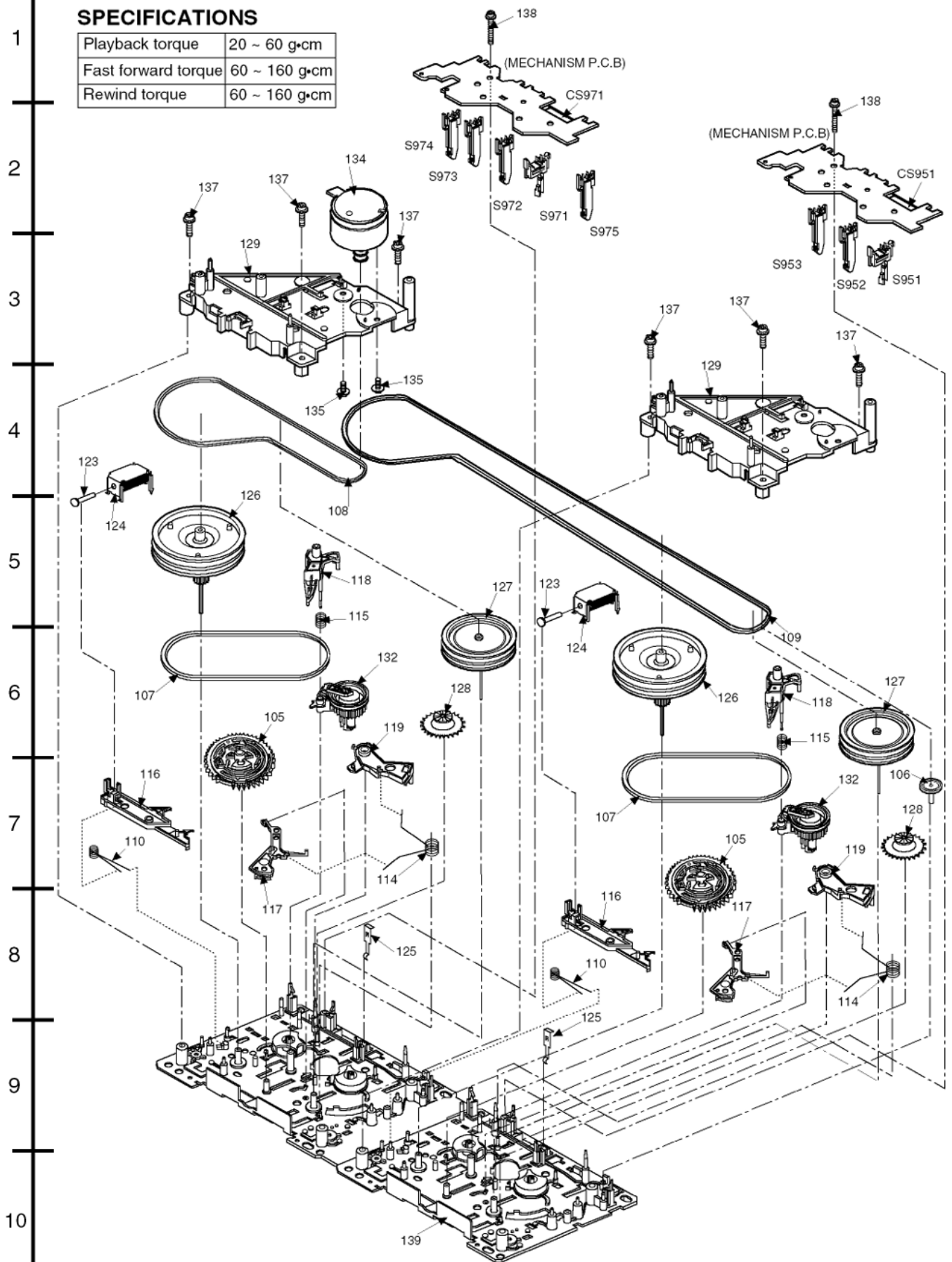

19.1.2. Deck Mechanism Parts List

Ref. No.	Part No.	Part Name & Description	Remarks
		CASSETTE DECK	
101	RED0063	P/B HEAD BLOCK UNIT	[M]
101-1	RHE5152ZB	SCREW	[M]
102	RED0064	R/P HEAD BLOCK UNIT	[M]
102-1	RHE5152ZB	SCREW	[M]
103	RDG0300	REEL BASE GEAR	[M]
104	RDG0301	WINDING RELAY GEAR	[M]
105	RDK0026	MAIN GEAR	[M]
106	RDR0029	RELAY PULLEY	[M]
107	RDV0033-4	WINDING BELT	[M]
108	RDV0034-1	CAPSTAN BELT 'A'	[M]
109	RDV0057	MAIN BELT B	[M]
110	RMB0312	TRIGGER LEVER SPRING	[M]
111	RMB0400	REEL SPRING	[M]
112	RMB0403	HEAB PANEL SPRING	[M]
113	RMB0404	BRAKE ROD SPRING	[M]
114	RMB0406	FR LEVER SP	[M]
115	RMB0408	THRUST SPRING	[M]
116	RML0370	TRIGGER LEVER	[M]
117	RML0371	FR LEVER	[M]
118	RML0372	WINDING LEVER	[M]
119	RML0374	EJECT LEVER	[M]
120	RMM0131	BRAKE ROD	[M]
121	RMM0133-1	EJECT ROD	[M]
122	RMQ0519	REEL HUB	[M]
123	RMS0398-1	MOVING CORE	[M]
124	RSJ0003	PLUNGER ASS'Y	[M]
125	RMC0061	PACK SPRING	[M]
126	RXF0049	FLYWHEEL 'F' ASS'Y	[M]
127	RXF0050	FLYWHEEL 'R' ASS'Y	[M]
128	RXG0040	FF RELAY GEAR ASS'Y	[M]
129	RMK0283A-J	SUB CHASSIS	[M]
130	RXL0124	PINCH ROLLER 'F' ASS	[M]
130-1	RMB0401	PINCH ARM SPRING 'F'	[M]
131	RXL0125	PINCH ROLLER 'R' ASS	[M]
131-1	RMB0402	PINCH ARM SPRING 'R'	[M]
132	RXL0126	WINDING ARM ASS'Y	[M]
133	RXQ0412	HEAD PANEL ASS'Y	[M]
133-1	RMB0405	FR ROD SPRING	[M]
133-2	RMM0132	FR ROD	[M]
134	REM0070	CAP MOTOR ASS'Y	[M]
135	RHD26022	MOTOR SCREW	[M]
136	XTW2+5L	HEAD BLOCK UNIT SCRE	[M]
137	XTW26+10S	SUB-CHASSIS SCREW	[M]
138	XYC2+JF17	PCB EARTH SCREW	[M]
139	RFKJXED70-K	CHASSIS ASS'Y	[M]

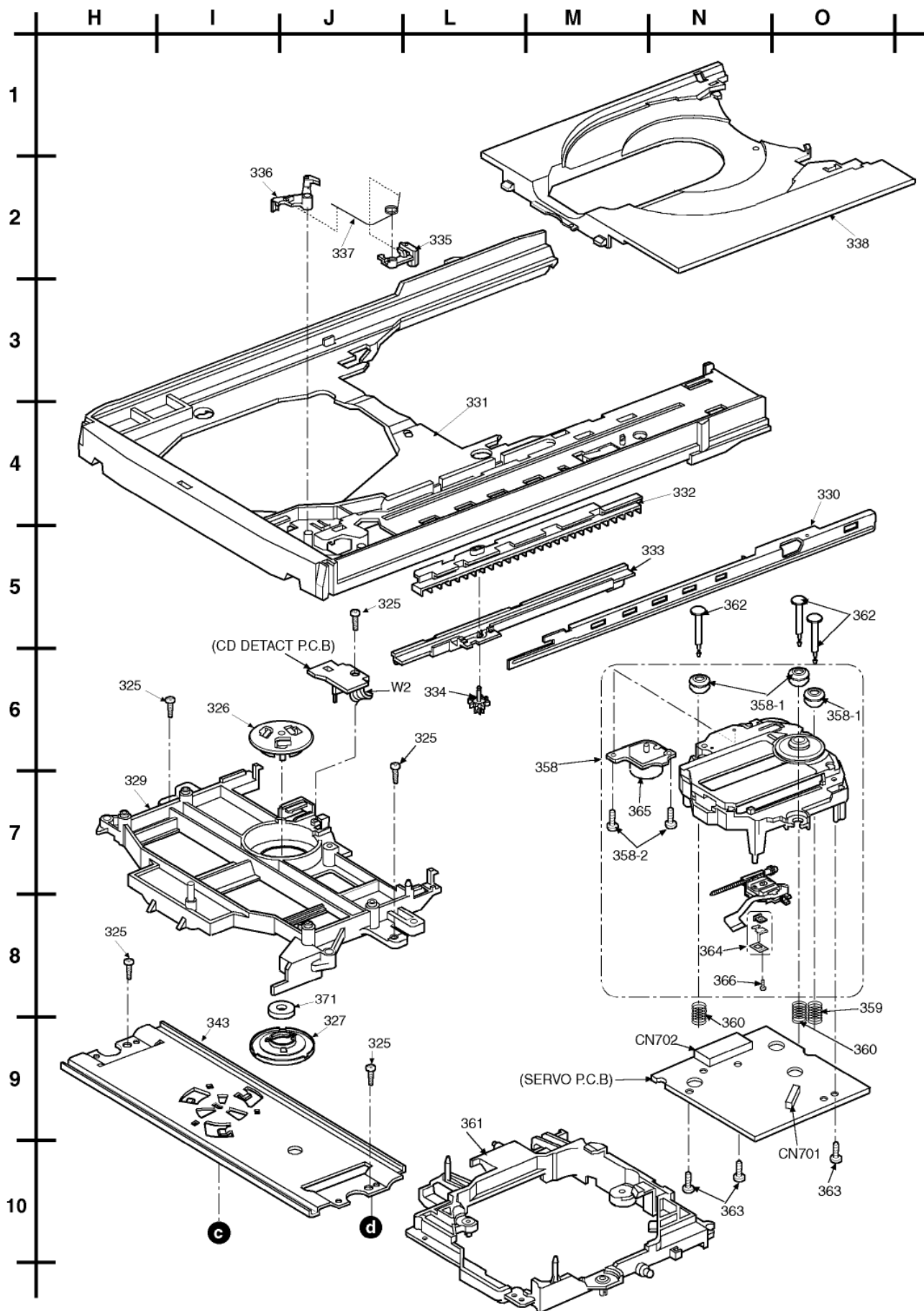

19.2.2. CD Loading Mechanism Parts List

Ref. No.	Part No.	Part Name & Description	Remarks
		TRAVERSE DECK	
301	RML0517	TIMING LEVER	[M]
302	RML0516	PLUNGER LEVER	[M]
303	RMB0551	UPPER SPINDLE SPRING	[M]
304	RMQ0744	LOWER HOOK	[M]
305	RDV0056	BELT	[M]
306	RML0525	FRONT LOCK LEVER	[M]
307	RML0526	DISC LEVER	[M]
308	RDG0424	DRIVE GEAR	[M]
309	RDG0425	CHANGE GEAR	[M]
310	RDG0427	TRAVERSE CAM GEAR	[M]
311	RDG0428	TRAVERSE RELAY GEAR	[M]
312	RDG0426	UP/DOWN GEAR	[M]
313	RDG0429	PULLEY GEAR	[M]
314	RMB0549-1	CHANGE GEAR SPRING	[M]
315	RMQ0748	PITCH PLATE	[M]
316	RMB0553	PUSH SPRING	[M]
317	RML0530	ASSIST LEVER	[M]
318	RML0518	CONNECTION LEVER	[M]
319	RMM0201	SLIDE PLATE 1	[M]
320	RME0258	REAR LOCK SPRING	[M]
321	RML0521	REAR LOCK	[M]
322	RME0257	TRAY LOCK LEVER SPRI	[M]
323	RML0520	TRAY LOCK	[M]
324	RMM0202	SLIDE PLATE 2	[M]
325	XTB3+10J	SCREW	[M]
326	RMR0334	FIXED PLATE	[M]
327	RMR0624-W2	CLAMPER	[M]
328	RMB0561	ASSIST LEVER SPRING	[M]
329	RMR1121-K	MECHA COVER	[M]
330	RMA1110-2	TRAY ANGLE	[M]
331	RMR1122-H1	TRAY BASE	[M]
332	RMM0204	CARRIER	[M]
333	RMM0203	DRIVE RACK	[M]
334	RDG0432	SPEED UP GEAR	[M]
335	RML0524	SLIDE LOCK	[M]
336	RML0523	CARRIER LOCK	[M]
337	RME0260-1	SLIDE LOCK SPRING	[M]
338	RMR1123-H	TRAY	[M]
339	RXQ0595	MOTOR SUB ASS'Y	[M]
341	RSJ0003	SOLENOID ASS'Y	[M]
343	RMA1106	UPPER PLATE	[M]
344	RML0519	8CD LEVER	[M]
345	RFKNAAK27GCS	MECHA BASE ASS'Y	[M]
346	RML0522	TURNING STOPPER	[M]
347	RMQ0745	LOWER SPINDLE	[M]
348	RMQ0746	UP/DOWN BASE	[M]
349	RMB0550	LOWER SPINDLE SPRING	[M]
350	RMQ0747	UPPER HOOK	[M]
351	RME0263	CLICK SPRING	[M]
352	RMQ0743	SPINDLE SHAFT	[M]
353	RMB0552	CUSHION SPRING	[M]
354	RDG0430	RELAY GEAR 'A'	[M]
355	RDG0431	RELAY GEAR 'B'	[M]
356	RME0262	DISK LEVER SP.	[M]
357	RMA1105	SUPPORT PLATE	[M]
358	RAE0152Z-3	TRAVERSE	[M]
358-1	SHGD113-1	FLOATING CUSHION	[M]
358-2	SNSD38	TRV MOTOR ASS'Y SCRE	[M]
359	RME0142	FLOATING SPRING A	[M]
360	RME0109	FLOATING SPRING B	[M]
361	RMR1124-K1	TRAVERSE CHASSIS	[M]
362	RMS0632	TRAVERSE PIN	[M]
363	XTN2+6G	SCREW	[M]
364	RXQ0304-1	NUT PLATE ASS'Y	[M]
365	RXQ0339	TRAVERSE MOTOR ASS'Y	[M]
366	XQN17+CG5	NUT PLATE ASS'Y SCRE	[M]
369	RMX0141	PUSH SPACER	[M]
370	RMQ0749	UPPER SPINDLE	[M]
371	RHM0001	MAGNET	[M]
372	RMX0140	DISC SPACER	[M]

Ref. No.	Part No.	Part Name & Description	Remarks
373	RME0261	FRONT LOCK SPRING	[M]
374	RMQ0742	SPINDLE BASE	[M]

19.3.2. Cabinet Parts List

Ref. No.	Part No.	Part Name & Description	Remarks
		CABINET AND CHASSIS	
2	REEX0065	20P FFC	[M]
3	REEX0081	19P FFC WIRE	[M]
4	REEX0082	26P FFC	[M]
5	REEX0083	14P FFC WIRE	[M]
8	RGPX0032D-S	FRONT PANEL	[M]GN
8	RGPX0032E-S	FRONT PANEL	[M]GC
9	RGK1198-K	CD ORNAMENT	[M]
10	RGL0467-Q	DISC SEL LIGHT	[M]
11	RGUX0346-S	POWER BUTTON	[M]
12	RGL0466-QJ	LIGHTING CHIP	[M]
13	RGUX0348-S	DISPLAY BTN	[M]
14	RGUX0341-S	KARAOKE BUTTON	[M]
15	RGUX0338-S	FUNCTION BUTTON	[M]
16	RGUX0336-S	CONTROL BTN	[M]
17	RGUX0337-S	DECK BTN	[M]
18	RXG0049	DAMPER GEAR UNIT	[M]
19	RMB0474	CASS OPEN SPRING	[M]
20	RGUX0340-S	RANDOM BTN	[M]
21	RGUX0347-S	DEMO BUTTON	[M]
22	RGU1805-S	V. BASS BUTTON	[M]
23	RGUX0339-Q	3D AI EQ BTN	[M]
24	RKF0585-K	CASS. HOLDER (L)	[M]
25	RKF0586-K	CASS. HOLDER (R)	[M]
26	RKFX0078-S	CASS LID (L)	[M]
27	RKFX0079-S	CASS LID (R)	[M]
28	RKWX0138-Q	CASS WIN (L)	[M]
29	RKWX0139-Q	CASS WIN (R)	[M]
30	RKW0593-V	FL WINDOW	[M]

Ref. No.	Part No.	Part Name & Description	Remarks
31	RKMX0046B-S	TOP CABINET (BENT)	[M]
32	RYQ0271-A1	JOY JOG UNIT	[M]
33	RGW0330A-S	VOLUME KNOB	[M]
34	RGWX0049-S	MIC KNOB	[M]GC
35	RGU1800-S	DISC BUTTON	[M]
36	RMK0439A	BOTTOM CHASSIS	[M]
37	RMNX0019	PCB SPACER	[M]
38	RMNX0029-4	SUB-TRANS HOLDER	[M]
39	RGRX0016C-A	REAR PANEL	[M]GC
39	RGRX0016D-A	REAR PANEL	[M]GN
40	SHE187-4	SPACER (TRANS)	[M]
41	SHR301	WIRE TIE	[M]GC
42	RGK1199-S	CD LID	[M]
43	RMNX0030	FL HOLDER	[M]
44	RSCX0044	FL SHIELD PLATE	[M]GC
45	RXX0019-1	HEATSINK UNIT	[M]
46	RMK0435-2	CD CHASSIS	[M]
47	RUS757ZAA	CASSETTE HALF SPRING	[M]
48	RSC0027-2	TUNER PACK	[M]
49	RKA0059-K	LEG RUBBER	[M]
50	RGB0113-N	PANA BADGE (HOOK TYP	[M]
51	RGKX0055-Q	3D AI SHEET	[M]
53	RHD30002-H	SCREW	[M]
55	XTB3+10J	SCREW	[M]
56	XTB3+10JFZ	SCREW	[M]
57	XTB3+20J1	SCREW	[M]
58	XTBS26+10J	SCREW	[M]
59	XTBS3+8JFZ1	SCREW	[M]
60	XTW3+12T	SCREW	[M]
61	XTW3+15T	SCREW	[M]

19.4. Electrical Parts List

Ref. No.	Part No.	Part Name & Description	Remarks
		P.C.B.	
	REP1999B	TUNER PACK UNIT	[M] (RTL)
	REP2578A-N	PCB ASS'Y	[M] (RTL)
	REPX0108	R/P PCB UNIT	[M] (RTL)
	REPX0108A	P/B PCB UNIT	[M] (RTL)
	REPX0192A	CD SERVO PCB	[M] (RTL)
	REPX0197E	PANEL PCB UNIT	[M] (RTL)GC
	REPX0197F	PANEL PCB UNIT	[M] (RTL)GN
	REPX0198A	DECK UNIT	[M] (RTL)
	REPX0199B	MAIN UNIT	[M] (RTL)GC
	REPX0200C	MAIN UNIT	[M] (RTL)GN
	REPX0202B	TRANSFORMER UNIT	[M] (RTL)GC
	REPX0203F	TRANSFORMER UNIT	[M] (RTL)GN
	REPX0204A	POWER PCB UNIT	[M] (RTL)
		INTEGRATED CIRCUITS	
IC1	TA7291P	IC DRIVE	[M]
IC101	LA1833NMNTLM	IC IF & MPX	[M]
IC102	LC72131MDTRM	IC PLL	[M]
IC302	M5218AP	IC BUFFER AMP	[M]
IC303	M62433AFP	IC AUDIO	[M]
IC500	RSN3502B	IC POWER	[M] △
IC501	STK470-010A	IC REGULATOR	[M] △
IC600	M38199MF227	IC MICRO PROCESSOR	[M]
IC601	BU2090AF-E2	IC I/O EXPANDER	[M]
IC603	M62457AFPE1	IC SPEANA	[M]
IC701	AN8839NSBE2	IC RF HEAD AMP	[M]
IC702	MN662790RSC	IC LSI	[M]
IC703	AN8739SBE2	IC 4CH DRIVER	[M]
IC951	ON2180RLC1	IC PHOTO INTERRUPTOR	[M]
IC971	ON2180RLC1	IC PHOTO INTERRUPTOR	[M]
IC1001	AN7348STA-E1	IC TAPE PB	[M]
IC1002	BU2090AF-E2	IC I/O EXPANDER	[M]
IC1003	BA4558FE2	IC	[M]
IC1004	BA7755A	IC SW	[M]

Ref. No.	Part No.	Part Name & Description	Remarks
		TRANSISTORS	
Q1	2SK544F-AC	TRANSISTOR	[M]
Q1	RVTDTC143EST	TRANSISTOR	[M]
Q2	2SC2786MTA	TRANSISTOR	[M]
Q3	2SC2787FL1TA	TRANSISTOR	[M]
Q4	2SC2787FL1TA	TRANSISTOR	[M]
Q101	2SC2058SPTA	TRANSISTOR	[M]
Q106	DTA114EKA146	TRANSISTOR	[M]GC
Q106	KRA102MTA	TRANSISTOR	[M]GN
Q107	DTC143XKA146	TRANSISTOR	[M]GC
Q151	2SA1309ARTA	TRANSISTOR	[M]GC
Q152	2SA1309ARTA	TRANSISTOR	[M]GC
Q153	2SA1309ARTA	TRANSISTOR	[M]GC
Q154	2SA1309ARTA	TRANSISTOR	[M]GC
Q155	2SC2412KT96R	TRANSISTOR	[M]GC
Q156	2SC2412KT96R	TRANSISTOR	[M]GC
Q157	2SC2412KT96R	TRANSISTOR	[M]GC
Q158	DTC114EKA146	TRANSISTOR	[M]GC
Q159	2SC2412KT96R	TRANSISTOR	[M]GC
Q200	KTD1304TA	TRANSISTOR	[M]
Q201	KTC3199GRTA	TRANSISTOR	[M]
Q304	KTC3875GRTA	TRANSISTOR	[M]
Q306	KRA102STA	TRANSISTOR	[M]
Q307	KRC111STA	TRANSISTOR	[M]
Q309	KRA102STA	TRANSISTOR	[M]
Q311	KRC111STA	TRANSISTOR	[M]
Q350	2SB621ARSTA	TRANSISTOR	[M]
Q351	KRC102STA	TRANSISTOR	[M]
Q352	KRA102STA	TRANSISTOR	[M]
Q400	KTD1304TA	TRANSISTOR	[M]
Q401	KTC3199GRTA	TRANSISTOR	[M]
Q500	KTC3199GRTA	TRANSISTOR	[M]
Q501	2SB1238QRTV2	TRANSISTOR	[M] △
Q502	KTC3199GRTA	TRANSISTOR	[M]
Q503	RVTDTA114EST	TRANSISTOR	[M]

Ref. No.	Part No.	Part Name & Description	Remarks
Q504	2SC2785FTA	TRANSISTOR	[M]
Q505	2SC2785FTA	TRANSISTOR	[M]
Q507	2SC1740SSTA	TRANSISTOR	[M]
Q508	2SC1740SSTA	TRANSISTOR	[M]
Q509	KRC110MTA	TRANSISTOR	[M]
Q510	KTC3199GRTA	TRANSISTOR	[M]
Q511	2SC1740SSTA	TRANSISTOR	[M]
Q600	2SC1740SSTA	TRANSISTOR	[M]GC
Q601	KTC3199GRTA	TRANSISTOR	[M]GC
Q602	KTA12710YTA	TRANSISTOR	[M]
Q605	KTC3199GRTA	TRANSISTOR	[M]
Q606	KTC3199GRTA	TRANSISTOR	[M]
Q607	KRC103MTA	TRANSISTOR	[M]
Q608	KTC3199GRTA	TRANSISTOR	[M]
Q609	KTC3199GRTA	TRANSISTOR	[M]
Q610	2SA933SSTA	TRANSISTOR	[M]
Q611	KRC102MTA	TRANSISTOR	[M]
Q701	2SA1037AKSTX	TRANSISTOR	[M]
Q901	RVTDTCL43EST	TRANSISTOR	[M]
Q902	RVTDTCL43EST	TRANSISTOR	[M]
Q903	RVTDTCL43EST	TRANSISTOR	[M]
Q975	2SC1740SSTA	TRANSISTOR	[M]
Q976	2SD2144STA	TRANSISTOR	[M]GC △
Q977	2SC3940AQSTA	TRANSISTOR	[M] △
Q978	KRC102MTA	TRANSISTOR	[M]
Q1001	2SC2784FTA	TRANSISTOR	[M]
Q1003	2SD2144STA	TRANSISTOR	[M]
Q1004	2SD2144STA	TRANSISTOR	[M]
Q1005	2SD2144STA	TRANSISTOR	[M]
Q1006	DTC144TKA146	TRANSISTOR	[M]
Q1007	KTC3875GRTA	TRANSISTOR	[M]
Q1008	KTC3875GRTA	TRANSISTOR	[M]
Q1009	KTC3875GRTA	TRANSISTOR	[M]
Q1010	KTC3875GRTA	TRANSISTOR	[M]
Q1011	KTC3875GRTA	TRANSISTOR	[M]
Q1012	KTD1304TA	TRANSISTOR	[M]
Q1013	KTD1304TA	TRANSISTOR	[M]
Q1014	2SC2412KT96R	TRANSISTOR	[M]
Q1015	2SC2412KT96R	TRANSISTOR	[M]
Q1016	DTA114EKA146	TRANSISTOR	[M]
Q1017	2SD965RTA	TRANSISTOR	[M]
Q1018	KTA12710YTA	TRANSISTOR	[M]
Q1019	KTA12710YTA	TRANSISTOR	[M]
Q1020	KTD1304TA	TRANSISTOR	[M]
Q1021	KTD1304TA	TRANSISTOR	[M]
Q1022	DTA114EKA146	TRANSISTOR	[M]
Q1023	DTA114EKA146	TRANSISTOR	[M]
Q1024	2SD2144STA	TRANSISTOR	[M]
		DIODES	
D1	GP1S94	DIODE	[M]
D1	SVC211SPA-AL	DIODE	[M]
D2	MTZJ4R7BTA	DIODE	[M]
D2	SVC211SPA-AL	DIODE	[M]
D3	SVC211SPA-AL	DIODE	[M]
D101	UDZSTE175R1B	DIODE	[M] △
D151	DA204KT146	DIODE	[M]GC
D302	UDZSTE175R1B	DIODE	[M] △
D306	DAP202KT146	DIODE	[M]
D307	DAP202KT146	DIODE	[M]
D308	1SS355TE17	DIODE	[M]
D309	1SS355TE17	DIODE	[M]
D311	1SS355TE17	DIODE	[M]
D312	RL1N4003S-P	DIODE	[M]
D313	1SS355TE17	DIODE	[M]
D314	RL1N4003S-P	DIODE	[M]
D316	RL1N4003S-P	DIODE	[M]
D500	1D3E	DIODE	[M]
D501	RL1N4003S-P	DIODE	[M]
D502	RL1N4003S-P	DIODE	[M]
D503	MTZJ30BTA	DIODE	[M] △
D504	MTZJ10BTA	DIODE	[M]
D506	MTZJ12BTA	DIODE	[M]

Ref. No.	Part No.	Part Name & Description	Remarks
D507	RL1N4003S-P	DIODE	[M] △
D508	RL1N4003S-P	DIODE	[M] △
D509	RL1N4003S-P	DIODE	[M] △
D510	1D3E	DIODE	[M] △
D511	MTZJ16BTA	DIODE	[M]
D512	MTZJ12BTA	DIODE	[M]
D513	MA165TA	DIODE	[M]
D514	MTZJ8R2BTA	DIODE	[M]
D515	RL1N4003S-P	DIODE	[M] △
D516	RL1N4003S-P	DIODE	[M] △
D519	RVD1SS133TA	DIODE	[M]
D520	RVD1SS133TA	DIODE	[M]
D521	RL1N4003S-P	DIODE	[M]
D522	RL1N4003S-P	DIODE	[M]
D604	SLI325DCT31	DIODE	[M]
D605	SLI325URCT31	DIODE	[M]
D610	SLR325MCT31W	DIODE	[M]
D611	SLR325MCT31W	DIODE	[M]
D612	SLR325MCT31W	DIODE	[M]
D613	SLR325MCT31W	DIODE	[M]
D614	SLR325MCT31W	DIODE	[M]
D615	SLR325MCT31W	DIODE	[M]
D617	SLR505DCT31	DIODE	[M]
D621	RVD1SS133TA	DIODE	[M]
D622	RVD1SS133TA	DIODE	[M]GC
D623	RVD1SS133TA	DIODE	[M]GC
D624	RVD1SS133TA	DIODE	[M]GC
D625	RVD1SS133TA	DIODE	[M]GN
D627	1SS291TA	DIODE	[M]
D628	1SS291TA	DIODE	[M]
D629	RVD1SS133TA	DIODE	[M]
D630	MA723TA	DIODE	[M]
D633	RVD1SS133TA	DIODE	[M]
D634	RVD1SS133TA	DIODE	[M]
D635	RVD1SS133TA	DIODE	[M]
D636	MA4020LTA	DIODE	[M]
D637	1SS291TA	DIODE	[M]
D638	RVD1SS133TA	DIODE	[M]
D639	RVD1SS133TA	DIODE	[M]
D640	MA700ATA	DIODE	[M]
D641	MA700ATA	DIODE	[M]
D642	MA700ATA	DIODE	[M]
D643	RVD1SS133TA	DIODE	[M]
D644	RVD1SS133TA	DIODE	[M]
D645	RVD1SS133TA	DIODE	[M]
D646	RVD1SS133TA	DIODE	[M]
D647	MA700ATA	DIODE	[M]
D951	MA165TA	DIODE	[M]
D971	MA165TA	DIODE	[M]
D977	RVD1SS133TA	DIODE	[M]
D978	1D3E	DIODE	[M]
D979	1D3E	DIODE	[M] △
D980	1D3E	DIODE	[M] △
D981	1D3E	DIODE	[M]
D982	MTZJ6R8BTA	DIODE	[M]GN △
D982	MTZJ7R5ATA	DIODE	[M]GC △
D983	1D3E	DIODE	[M]GC
D984	1SS291TA	DIODE	[M]GC
D985	1D3E	DIODE	[M]GN △
D986	1D3E	DIODE	[M]GN △
D1002	1SS355TE17	DIODE	[M]
D1003	1SS355TE17	DIODE	[M]
D1004	UDZTE173R6B	DIODE	[M]
		VARIABLE RESISTORS	
VR600	EVEKE2F3024B	VR VOL. JOG	[M]
VR601	EVUF2AF20B14	VR MIC	[M]GC
		SWITCHES	
S501	RSR4B007S-Q	SW VOLT ADJ	[M]GC △
S602	EVQ21405R	SW AUX	[M]
S603	EVQ21405R	SW DECK 1 EJECT	[M]

Ref. No.	Part No.	Part Name & Description	Remarks
S604	EVQ21405R	SW CD MANAGER	[M]
S605	EVQ21405R	SW TUNER	[M]
S606	EVQ21405R	SW TAPE EDIT	[M]
S607	EVQ11G05R	SW EJECT 5	[M]
S608	EVQ21405R	SW CD	[M]
S609	EVQ21405R	SW REC/STOP	[M]
S610	EVQ11G05R	SW DISC 5	[M]
S611	EVQ21405R	SW TAPE	[M]
S612	EVQ21405R	SW REV	[M]
S613	EVQ11G05R	SW EJECT 4	[M]
S614	EVQ11G07K	SW SOUND EQ UP	[M]
S615	EVQ21405R	SW S. WOOFER	[M]
S616	EVQ21405R	SW DECK 2 EJECT	[M]
S617	EVQ11G05R	SW DISC 4	[M]
S618	EVQ11G07K	SW SOUND LEFT	[M]
S619	EVQ21405R	SW DISPLAY/DEMO	[M]
S620	EVQ21405R	SW TUNE DOWN	[M]
S621	EVQ21405R	SW CLOCK/TIMER	[M]
S622	EVQ11G07K	SW SOUND UP	[M]
S623	EVQ11G05R	SW EJECT 3	[M]
S624	EVQ21405R	SW KARAOKE	[M]GC
S625	EVQ21405R	SW PLAY/REC	[M]
S626	EVQ11G07K	SW SOUND RIGHT	[M]
S627	EVQ11G05R	SW DISC 3	[M]
S628	EVQ21405R	SW ECO MODE	[M]
S629	EVQ21405R	SW TUNE MODE	[M]
S630	EVQ11G05R	SW EJECT 2	[M]
S631	EVQ21405R	SW RANDOM	[M]
S632	EVQ21405R	SW MEMORY	[M]
S633	EVQ11G05R	SW DISC 2	[M]
S634	EVQ21405R	SW TUNER UP	[M]
S635	EVQ11G05R	SW EJECT 1	[M]
S636	EVQ11G05R	SW DISC 1	[M]
S637	EVQ21405R	SW FM MODE/BP	[M]
S638	EVQ21405R	SW POWER	[M]
S639	EVQ21405R	SW 3D AI EQ	[M]
S701	RSH1A043-U	SW REST	[M]
S951	RSH1A018-3U	SW LEAF	[M]
S952	RSH1A019-2U	SW LEAF	[M]
S953	RSH1A019-2U	SW LEAF	[M]
S971	RSH1A018-3U	SW LEAF	[M]
S972	RSH1A019-2U	SW LEAF	[M]
S973	RSH1A019-2U	SW LEAF	[M]
S974	RSH1A019-2U	SW LEAF	[M]
S975	RSH1A019-2U	SW LEAF	[M]
SW1	RSH1A032-U	SW PUSH	[M]
SW2	RSH1A032-U	SW PUSH	[M]
SW3	RSH1A005-1U	SW	[M]
SW4	RSH1A91ZA-A	SW CD	[M]
SW5	RSP1A017-A	SW LOCK	[M]
SW600	ESE24SV2	SW JOY JOG	[M]
		CONNECTORS	
CN1	RJS1A9414	FF CONNECTOR	[M]
CN300	RJU057G12	12P P2 MQ CONNECTOR	[M]
CN301	RJU057G12	12P P2 MQ CONNECTOR	[M]
CN302	RJS1A9426-1	26P FFC CONNECTOR	[M]
CN303	RJS1A9420	20P FFC CONNECTOR	[M]
CN304	RJS1A5210	10P WIRE HOLDER	[M]
CN309	RJS1A9414-1	14P CONNECTOR	[M]
CN500	RJT029W03V-1	CONNECTOR	[M]GC
CN501	RJT029W008-1	8P SIDE CONNECTOR	[M]
CN502	RJP6G18ZA	SOCKET	[M]
CN600	RJT071K09	9P P2 BTOB CONNECTOR	[M]
CN701	RJS2A6016	16P FFC CONNECTOR	[M]
CN702	RJS1A6719-1Q	19P FFC CONNECTOR	[M]
CN1001	RJS8T7ZA	8P MOLEX	[M]
CP500	RJT057G12	12P P2 MQ CONNECTOR	[M]
CP501	RJT057G12	12P P2 MQ CONNECTOR	[M]
CP600	RJU071H09M	CONNECTOR	[M]
CP604	RJS1A9426-1	26P FFC CONNECTOR	[M]
CP605	RJS1A9420	20P FFC CONNECTOR	[M]
CP606	RJS1A6219-1	19P FFC CONNECTOR	[M]

Ref. No.	Part No.	Part Name & Description	Remarks
CP1001	RJT071K09A	9P B/B CONNECTOR	[M]
CP1002	RJT071K09A	9P B/B CONNECTOR	[M]
CS951	RJU071H09M1	CONNECTOR	[M]
CS971	RJU071H09M1	CONNECTOR	[M]
CS1001	RJS1A6805-J	5P CONNECTOR SOCKET	[M]
CS1002	RJS1A6805-J	5P CONNECTOR SOCKET	[M]
		COILS & TRANSFORMERS	
L1	RLQZP1R2KT-Y	COIL	[M]
L2	RLQZPR47KT-Y	COIL	[M]
L102	RLQB1R0KTD-D	INDUCTOR	[M]GN
L104	RLQB101JTD-D	INDUCTOR	[M]GC
L600	RLQB101JTD-D	INDUCTOR	[M]
L601	RLQB100JTD-D	INDUCTOR	[M]
L602	RLQB101JTD-D	INDUCTOR	[M]
L603	RLQZP3R3KT-Y	AXIAL COIL	[M]
L604	RLQZP101KT-Y	AXIAL COIL	[M]
L605	RLQZP101KT-Y	AXIAL COIL	[M]
L606	RLQZP3R3KT-Y	AXIAL COIL	[M]GC
L607	RLQZP3R3KT-Y	AXIAL COIL	[M]GC
L1001	RLQB470JTD-D	RF CHOKE COIL	[M]
L1002	7L1A62N	BIAS OSC COIL	[M]
T501	RTP1N3E013-V	POWER TRANSFORMER	[M]GC △
T501	RTP2N3B009	POWER TRANSFORMER	[M]GN △
T502	RTP1H3E001	BACKUP TRANSFORMER	[M]GC △
T502	RTP1I3E002-V	BACK UP TRANSFORMER	[M]GN △
		COMPONENT COMBINATION	
Z101	RLA2Z007-T	COIL	[M]GN
Z102	RLI2Z020-T	IF COIL BLOCK	[M]GC
Z102	RLI2Z021M-T	AM IF BLOCK	[M]GN
Z151	RLA3Z002-C	COIL BLOCK	[M]GC
Z152	RLA5Z002-C	COIL BLOCK	[M]GC
Z501	ERZV10V511CS	ZENER	[M] △
Z602	RCDRPM6937H4	REMOTE CTRL SENSOR	[M]
Z971	EXBP7L355SYV	RADA RESISTOR	[M]
Z1001	RGSD12A1445T	SENSOR	[M]
Z1002	RGSD12A1445T	SENSOR	[M]
		CERAMIC FILTERS	
CF201	RLFFETWND01M	FM CF	[M]
CF202	RLFFETWND01M	FM CF	[M]
		RELAY	
RL500	RSY0017M-0	RELAY	[M] △
RL502	RSY0040M-0	PRIMARY RELAY	[M]GN △
RL502	RSY0056M-C	PRIMAY RELAY	[M]GC △
		OSCILLATORS	
X102	RLFDFT22DD	DISCRIMINATOR	[M]
X103	RSXC7M20S05T	CRYSTAL OSCILLATOR	[M]
X600	RSXZ8M00D01T	CERAMIC RESONATOR	[M]
X601	RSXD32K7S02	32.768HKZ X'TAL	[M]
X701	RSXZ16M9M01T	CERAMIC OSC	[M]
		DISPLAY TUBE	
FL600	RSL0295-F	FL DISPLAY	[M]
		FUSES	
F1	XBA2C10TB0	1A PRIMARY FUSE	[M]GN △
F1	XBA2C25TB0	NIL	[M]GC △
F2	XBA2C12TB0	FUSE	[M]GC △
		FUSE HOLDER	
FC1	EYF52BC	FUSE HOLDER	[M]
FC2	EYF52BC	FUSE HOLDER	[M]

Ref. No.	Part No.	Part Name & Description	Remarks
FC3	EYF52BC	FUSE HOLDER	[M]GC
FC4	EYF52BC	FUSE HOLDER	[M]GC
		HOLDER	
H500	RJS1A5508	WIRE HOLDER	[M]
H600	RMR0317	8P CABLE HOLDER	[M]
H601	RMR0315	6P CABLE HOLDER	[M]
H602A	RMR0317	8P CABLE HOLDER	[M]
H602B	RMR0317	8P CABLE HOLDER	[M]
H1001	RMR0319	10P CABLE HOLDER	[M]
		JACKS	
JK101	RJH5414	JK, ANTENNA	[M]
JK305	RJH2206	JK RCA	[M]GN
JK305	RJH2213N	JK AUX	[M]GC
JK500	RJR0054B-J	JK SPEAKER	[M]
JK500	SJS9236-1	JK AC IN	[M] △
JK600	RJJ37TK07-X	JK, HP/MIC	[M]
JK601	RJJ37TK07-X	JK, HP/MIC	[M]GC
		EARTH TERMINAL	
E500	SNE1004-2	EARTH TERMINAL	[M]
		WIRES	
W1	REE0854	PRI WIRE YELLOW	[M]GC
W1	REEX0089	PRIMARY WIRE (YELLOW)	[M]GN
W1	REZ1023-1	4P WIRE	[M]
W2	REEX0032	PRI WIRE (BLACK)	[M]GN
W2	REZ1024	3P WIRE	[M]
W5	REEX0057	WIRE (ORANGE)	[M]GC
W6	REE0782	WIRE (GREY)	[M]GC
W7	REEX0059	WIRE (BLUE)	[M]GC
W8	REEX0086	WIRE (RED)	[M]GC
W9	REEX0061	WIRE (BLACK)	[M]GC
W10	REEX0062	WIRE (WHITE)	[M]GC
W500	REXX0202	2P TRANSFORMER WIRE	[M]GN
W500	REXX0206	STANDBY BY WIRE	[M]GC
W600	RWJ0208155RX	WIRE 8P PANEL TO DEC	[M]
W601	REXX0223	6P WIRE	[M]
W602	RWJ110808ORR	8P WIRE	[M]
W1001	RWJ8010160RX	10P DECK TO PANEL	[M]
W1002	RWJ0102065CK	MOTOR WIRE (DECK)	[M]
		JUMPER PLATE	
PL1	RJR0199	JUMPER PLATE	[M]GC
		RESISTORS	
R1	ERDS2TJ102T	1K 1/4W	[M]
R1	ERDS2TJ104T	100K 1/4W	[M]
R2	ERDS2TJ104T	100K 1/4W	[M]
R3	ERDS2TJ221T	220 1/4W	[M]
R4	ERDS2TJ104T	100K 1/4W	[M]
R5	ERDS2TJ564T	560K 1/4W	[M]
R6	ERDS2TJ391T	390 1/4W	[M]
R7	ERDS2TJ272T	2.7K 1/4W	[M]
R8	ERDS2TJ684T	680K 1/4W	[M]
R9	ERDS2TJ391T	390 1/4W	[M]
R10	ERDS2TJ391T	390 1/4W	[M]
R11	ERDS2TJ684T	680K 1/4W	[M]
R102	ERJ6GEYJ472V	4.7K 1/10W	[M]
R103	ERJ6GEYJ271V	270 1/10W	[M]
R104	ERJ6GEYJ102V	1K 1/10W	[M]
R105	ERJ6GEYJ471V	470 1/10W	[M]
R106	ERJ6GEYJ474V	470K 1/10W	[M]
R107	ERJ6GEYJ331V	330 1/10W	[M]
R108	ERJ6GEYJ273V	27K 1/10W	[M]GC
R110	ERJ6GEYJ102V	1K 1/10W	[M]GN
R111	ERJ6GEYJ391V	390 1/10W	[M]

Ref. No.	Part No.	Part Name & Description	Remarks
R112	ERJ6GEYJ104V	100K 1/10W	[M]GN
R113	ERJ6GEYJ103V	10K 1/10W	[M]
R114	ERJ6GEYJ562V	5.6K 1/10W	[M]
R115	ERJ6GEYJ561V	560 1/10W	[M]
R116	ERJ6GEYJ102V	1K 1/10W	[M]
R117	ERJ6GEYJ473V	47K 1/10W	[M]
R118	ERJ6GEYJ332V	3.3K 1/10W	[M]
R119	ERJ6GEYJ472V	4.7K 1/10W	[M]
R120	ERJ6GEYJ473V	47K 1/10W	[M]
R121	ERJ6GEYJ223V	22K 1/10W	[M]
R122	ERJ6GEYJ272V	2.7K 1/10W	[M]
R123	ERJ6GEYJ683V	68K 1/10W	[M]
R124	ERJ6GEYJ330V	33 1/10W	[M]
R125	ERJ6GEYJ471V	470 1/10W	[M]
R126	ERJ6GEYJ102V	1K 1/10W	[M]
R127	ERJ6GEYJ471V	470 1/10W	[M]
R128	ERJ6GEYJ820V	82 1/10W	[M]
R129	ERJ6GEYJ273V	27K 1/10W	[M]
R130	ERJ6GEYJ103V	10K 1/10W	[M]
R131	ERJ6GEYJ680V	68 1/10W	[M]GC
R131	ERJ8GEYJ680V	68 1/8W	[M]GN
R132	ERJ6GEYJ103V	10K 1/10W	[M]
R133	ERJ6GEYJ102V	1K 1/10W	[M]
R134	ERJ6GEYJ471V	470 1/10W	[M]
R135	ERJ6GEYJ102V	1K 1/10W	[M]
R136	ERJ6GEYJ102V	1K 1/10W	[M]
R137	ERJ6GEYJ102V	1K 1/10W	[M]
R138	ERJ6GEYJ332V	3.3K 1/10W	[M]
R139	ERJ6GEYJ562V	5.6K 1/10W	[M]GC
R141	ERJ6GEYJ682V	6.8K 1/10W	[M]
R142	ERJ6GEYJ682V	6.8K 1/10W	[M]
R143	ERJ6GEYJ223V	22K 1/10W	[M]
R145	ERJ6GEYJ104V	100K 1/10W	[M]
R146	ERJ6GEYJ104V	100K 1/10W	[M]
R151	ERJ6GEYJ153V	15K 1/10W	[M]GC
R151	ERJ6GEYJ820V	82 1/10W	[M]GN
R152	ERJ6GEYJ0R00V	0 1/10W	[M]GN
R152	ERJ6GEYJ333V	33K 1/10W	[M]GC
R153	ERJ6GEYJ153V	15K 1/10W	[M]GC
R154	ERJ6GEYJ683V	68K 1/10W	[M]GC
R155	ERJ6GEYJ103V	10K 1/10W	[M]GC
R156	ERJ6GEYJ103V	10K 1/10W	[M]GC
R157	ERJ6GEYJ102V	1K 1/10W	[M]GC
R158	ERJ6GEYJ102V	1K 1/10W	[M]GC
R159	ERJ6GEYJ820V	82 1/10W	[M]GC
R160	ERJ6GEYJ822V	8.2K 1/10W	[M]GC
R161	ERJ6GEYJ103V	10K 1/10W	[M]GC
R162	ERJ6GEYJ222V	2.2K 1/10W	[M]GC
R164	ERJ6GEYJ223V	22K 1/10W	[M]GC
R165	ERJ6GEYJ472V	4.7K 1/10W	[M]GC
R166	ERJ6GEYJ104V	100K 1/10W	[M]GC
R167	ERJ6GEYJ152V	1.5K 1/10W	[M]GC
R168	ERJ6GEYJ153V	15K 1/10W	[M]GC
R169	ERJ6GEYJ223V	22K 1/10W	[M]GC
R171	ERJ6GEYJ103V	10K 1/10W	[M]GC
R172	ERJ6GEYJ184V	180K 1/10W	[M]GC
R201	ERJ6GEYJ103V	10K 1/10W	[M]
R202	ERJ6GEYJ392V	3.9K 1/10W	[M]
R207	ERJ6GEYJ152V	1.5K 1/10W	[M]
R208	ERJ6GEYJ103V	10K 1/10W	[M]
R209	ERJ6GEYJ473V	47K 1/10W	[M]
R210	ERJ6GEYJ102V	1K 1/10W	[M]
R211	ERJ6GEYJ222V	2.2K 1/10W	[M]
R212	ERJ6GEYJ472V	4.7K 1/10W	[M]
R213	ERJ6GEYJ393V	39K 1/10W	[M]
R215	ERJ6GEYJ102V	1K 1/10W	[M]
R216	ERJ6GEYJ562V	5.6K 1/10W	[M]
R217	ERJ6GEYJ683V	68K 1/10W	[M]
R218	ERJ6GEYJ332V	3.3K 1/10W	[M]
R219	ERJ6GEYJ472V	4.7K 1/10W	[M]
R220	ERJ6GEYJ104V	100K 1/10W	[M] △
R221	ERJ6GEYJ102V	1K 1/10W	[M]
R222	ERJ6GEYJ472V	4.7K 1/10W	[M]
R223	ERJ6GEYJ473V	47K 1/10W	[M]

Ref. No.	Part No.	Part Name & Description	Remarks
R224	ERJ6GEYJ153V	15K 1/10W	[M]
R225	ERJ6GEYJ332V	3.3K 1/10W	[M]
R226	ERJ6GEYJ101V	100 1/10W	[M]
R228	ERJ6GEYJ102V	1K 1/10W	[M]
R233	ERJ6GEYJ184V	180K 1/10W	[M]GC
R233	ERJ6GEYJ224V	220K 1/10W	[M]GN
R236	ERJ6GEYJ222V	2.2K 1/10W	[M]
R248	ERJ6GEYJ390V	39 1/10W	[M]
R249	ERJ6GEYJ390V	39 1/10W	[M]
R300	ERJ6GEYJ472V	4.7K 1/10W	[M]
R301	ERJ6GEYJ223V	22K 1/10W	[M]
R302	ERJ6GEYJ183V	18K 1/10W	[M]
R303	ERJ6GEYJ100V	10 1/10W	[M]
R304	ERJ6GEYJ223V	22K 1/10W	[M]
R305	ERJ6GEYJ103V	10K 1/10W	[M]
R306	ERJ6GEYJ122V	1.2K 1/10W	[M]
R307	ERJ6GEYJ103V	10K 1/10W	[M]
R308	ERJ6GEYJ332V	3.3K 1/10W	[M]
R309	ERJ6GEYJ332V	3.3K 1/10W	[M]
R310	ERJ6GEYJ102V	1K 1/10W	[M]
R312	ERJ6GEYJ2R2V	2.2 1/10W	[M]
R313	ERJ6GEYJ393V	39K 1/10W	[M]
R316	ERJ6GEYJ153V	15K 1/10W	[M]
R317	ERJ6GEYJ102V	1K 1/10W	[M]
R321	ERJ6GEYJ2R7V	2.7 1/10W	[M]
R322	ERJ6GEYJ271V	270 1/10W	[M]
R323	ERJ6GEYJ222V	2.2K 1/10W	[M]
R324	ERJ6GEYJ222V	2.2K 1/10W	[M]
R325	ERJ6GEYJ222V	2.2K 1/10W	[M]
R326	ERJ6GEYJ683V	68K 1/10W	[M]
R327	ERJ6GEYJ154V	150K 1/10W	[M]
R344	ERJ6GEYJ103V	10K 1/10W	[M]
R345	ERJ6GEYJ221V	220 1/10W	[M]
R346	ERJ6GEYJ223V	22K 1/10W	[M]
R347	ERJ6GEYJ123V	12K 1/10W	[M]
R349	ERJ6GEYJ103V	10K 1/10W	[M]
R350	ERJ6GEYJ102V	1K 1/10W	[M]
R351	ERJ6GEYJ103V	10K 1/10W	[M]
R353	ERJ6GEYJ103V	10K 1/10W	[M]
R354	ERJ6GEYJ123V	12K 1/10W	[M]
R355	ERJ6GEYJ223V	22K 1/10W	[M]
R358	ERJ6GEYJ473V	47K 1/10W	[M]
R359	ERJ6GEYJ473V	47K 1/10W	[M]
R360	ERJ6GEYJ154V	150K 1/10W	[M]
R361	ERJ6GEYJ683V	68K 1/10W	[M]
R401	ERJ6GEYJ103V	10K 1/10W	[M]
R402	ERJ6GEYJ392V	3.9K 1/10W	[M]
R407	ERJ6GEYJ152V	1.5K 1/10W	[M]
R408	ERJ6GEYJ103V	10K 1/10W	[M]
R409	ERJ6GEYJ473V	47K 1/10W	[M]
R410	ERJ6GEYJ102V	1K 1/10W	[M]
R411	ERJ6GEYJ222V	2.2K 1/10W	[M]
R412	ERJ6GEYJ472V	4.7K 1/10W	[M]
R413	ERJ6GEYJ393V	39K 1/10W	[M]
R415	ERJ6GEYJ102V	1K 1/10W	[M]
R416	ERJ6GEYJ562V	5.6K 1/10W	[M]
R417	ERJ6GEYJ683V	68K 1/10W	[M]
R418	ERJ6GEYJ332V	3.3K 1/10W	[M]
R419	ERJ6GEYJ472V	4.7K 1/10W	[M]
R420	ERJ6GEYJ104V	100K 1/10W	[M]
R421	ERJ6GEYJ102V	1K 1/10W	[M]
R422	ERJ6GEYJ472V	4.7K 1/10W	[M]
R423	ERJ6GEYJ473V	47K 1/10W	[M]
R424	ERJ6GEYJ153V	15K 1/10W	[M]
R425	ERJ6GEYJ332V	3.3K 1/10W	[M]
R426	ERJ6GEYJ101V	100 1/10W	[M]
R428	ERJ6GEYJ102V	1K 1/10W	[M]
R433	ERJ6GEYJ184V	180K 1/10W	[M]GC
R433	ERJ6GEYJ224V	220K 1/10W	[M]GN
R436	ERJ6GEYJ222V	2.2K 1/10W	[M]
R448	ERJ6GEYJ390V	39 1/10W	[M]
R449	ERJ6GEYJ390V	39 1/10W	[M]
R452	ERJ6GEYJ103V	10K 1/10W	[M]
R453	ERJ6GEYJ472V	4.7K 1/10W	[M]

Ref. No.	Part No.	Part Name & Description	Remarks
R454	ERJ6GEYJ103V	10K 1/10W	[M]
R455	ERJ6GEYJ103V	10K 1/10W	[M]
R456	ERJ6GEYJ472V	4.7K 1/10W	[M]
R500	ERDS2TJ104T	100K 1/4W	[M]
R501	ERDS2TJ104T	100K 1/4W	[M]
R502	ERDS2TJ123T	12K 1/4W	[M]
R503	ERDS2TJ123T	12K 1/4W	[M]
R504	ERDS2TJ102T	1K 1/4W	[M]
R505	ERDS2TJ102T	1K 1/4W	[M]
R506	ERDS2TJ823T	82K 1/4W	[M]
R507	ERDS2TJ151T	150 1/4W	[M]
R508	ERDS2TJ562T	5.6K 1/4W	[M]
R509	ERDS2TJ102T	1K 1/4W	[M]
R510	ERDS2TJ472T	4.7K 1/4W	[M]
R511	ERDS2TJ683T	68K 1/4W	[M]
R513	ERDS2TJ683T	68K 1/4W	[M]
R515	ERDS2TJ152T	1.5K 1/4W	[M]
R516	ERD2FCVJ4R7T	4.7 1/4W	[M]
R517	ERDS2TJ823T	82K 1/4W	[M]
R518	ERDS2TJ683T	68K 1/4W	[M]
R520	ERD25FVJ4R7T	4.7 1/4W	[M]
R522	ERDS2TJ562T	5.6K 1/4W	[M]
R523	ERDS2TJ683T	68K 1/4W	[M]
R524	ERDS2TJ103T	10K 1/4W	[M]
R525	ERDS2TJ334T	330K 1/4W	[M]
R526	ERDS2TJ223T	22K 1/4W	[M]
R527	ERDS2TJ152T	1.5K 1/4W	[M]
R528	ERDS2TJ152T	1.5K 1/4W	[M]
R529	ERDS2TJ563T	56K 1/4W	[M]
R531	ERDS1FVJ392T	3.9K 1/2W	[M] △
R532	ERDS2TJ273T	27K 1/4W	[M]
R533	ERDS2TJ273T	27K 1/4W	[M]
R534	ERDS1FVJ392T	3.9K 1/2W	[M] △
R535	ERDS1FVJ150T	15 1/2W	[M] △
R536	ERD2FCVJ220T	22 1/4W	[M] △
R538	ERDS2TJ104T	100K 1/4W	[M]
R539	ERDS2TJ103T	10K 1/4W	[M]
R540	ERDS1FVJ470T	47 1/2W	[M] △
R541	ERDS1FVJ470T	47 1/2W	[M] △
R542	ERDS2TJ124T	120K 1/4W	[M]
R543	ERDS2TJ332T	3.3K 1/4W	[M]
R544	ERDS1FVJ100T	10 1/2W	[M] △
R545	ERDS1FVJ100T	10 1/2W	[M] △
R546	ERDS2TJ104T	100K 1/4W	[M]
R547	ERDS2TJ103T	10K 1/4W	[M]
R548	ERDS2TJ101T	100 1/4W	[M]
R549	ERDS2TJ222T	2.2K 1/4W	[M]
R550	ERDS2TJ392T	3.9K 1/4W	[M]
R551	ERDS2TJ471T	470 1/4W	[M]
R552	ERDS2TJ472T	4.7K 1/4W	[M]
R553	ERDS1FVJ270T	27 1/2W	[M] △
R554	ERDS1FVJ390T	39 1/2W	[M] △
R555	ERDS1FVJ390T	39 1/2W	[M] △
R556	ERDS2TJ124T	120K 1/4W	[M]
R600	ERDS2TJ222T	2.2K 1/4W	[M]
R603	ERDS2TJ122T	1.2K 1/4W	[M]
R604	ERDS2TJ182T	1.8K 1/4W	[M]
R605	ERDS2TJ103T	10K 1/4W	[M]
R606	ERDS2TJ683T	68K 1/4W	[M]
R607	ERDS2TJ102T	1K 1/4W	[M]
R608	ERDS2TJ682T	6.8K 1/4W	[M]
R609	ERDS2TJ223T	22K 1/4W	[M]
R610	ERDS2TJ102T	1K 1/4W	[M]
R611	ERDS2TJ472T	4.7K 1/4W	[M]
R613	ERDS2TJ103T	10K 1/4W	[M]
R615	ERDS2TJ223T	22K 1/4W	[M]
R616	ERDS2TJ272T	2.7K 1/4W	[M]
R617	ERDS2TJ682T	6.8K 1/4W	[M]
R618	ERDS2TJ103T	10K 1/4W	[M]
R619	ERDS2TJ221T	220 1/4W	[M]GC
R620	ERDS2TJ334T	330K 1/4W	[M]GC
R622	ERDS2TJ562T	5.6K 1/4W	[M]
R623	ERDS2TJ272T	2.7K 1/4W	[M]
R624	ERDS2TJ222T	2.2K 1/4W	[M]

Ref. No.	Part No.	Part Name & Description	Remarks
R628	ERDS2TJ470T	47 1/4W	[M]GC
R629	ERDS2TJ122T	1.2K 1/4W	[M]
R630	ERDS2TJ682T	6.8K 1/4W	[M]
R631	ERDS2TJ472T	4.7K 1/4W	[M]
R632	ERDS2TJ822T	8.2K 1/4W	[M]GC
R633	ERDS2TJ182T	1.8K 1/4W	[M]
R634	ERDS2TJ102T	1K 1/4W	[M]
R635	ERDS2TJ472T	4.7K 1/4W	[M]
R636	ERDS2TJ683T	68K 1/4W	[M]
R637	ERDS2TJ334T	330K 1/4W	[M]GC
R638	ERDS2TJ272T	2.7K 1/4W	[M]
R639	ERDS2TJ102T	1K 1/4W	[M]
R640	ERDS2TJ122T	1.2K 1/4W	[M]
R641	ERDS2TJ182T	1.8K 1/4W	[M]
R642	ERDS2TJ392T	3.9K 1/4W	[M]
R643	ERDS2TJ472T	4.7K 1/4W	[M]GC
R644	ERDS2TJ222T	2.2K 1/4W	[M]
R645	ERDS2TJ123T	12K 1/4W	[M]
R647	ERDS2TJ222T	2.2K 1/4W	[M]
R648	ERDS2TJ102T	1K 1/4W	[M]
R649	ERDS2TJ182T	1.8K 1/4W	[M]
R650	ERDS2TJ681T	680 1/4W	[M]
R651	ERDS2TJ101T	100 1/4W	[M]GC
R652	ERDS2TJ102T	1K 1/4W	[M]
R653	ERDS2TJ122T	1.2K 1/4W	[M]
R654	ERDS2TJ471T	470 1/4W	[M]
R655	ERDS2TJ471T	470 1/4W	[M]
R656	ERDS2TJ102T	1K 1/4W	[M]
R657	ERDS2TJ471T	470 1/4W	[M]
R658	ERDS2TJ101T	100 1/4W	[M]
R659	ERDS2TJ471T	470 1/4W	[M]
R660	ERDS2TJ102T	1K 1/4W	[M]
R661	ERDS2TJ471T	470 1/4W	[M]
R662	ERDS2TJ102T	1K 1/4W	[M]
R663	ERDS2TJ102T	1K 1/4W	[M]
R664	ERDS2TJ104T	100K 1/4W	[M]
R665	ERDS2TJ104T	100K 1/4W	[M]
R666	ERDS2TJ104T	100K 1/4W	[M]
R667	ERDS2TJ104T	100K 1/4W	[M]
R668	ERDS2TJ104T	100K 1/4W	[M]
R669	ERDS2TJ104T	100K 1/4W	[M]
R670	ERDS2TJ104T	100K 1/4W	[M]
R671	ERDS2TJ104T	100K 1/4W	[M]
R672	ERDS2TJ104T	100K 1/4W	[M]
R673	ERDS2TJ104T	100K 1/4W	[M]
R674	ERDS2TJ104T	100K 1/4W	[M]
R675	ERDS2TJ104T	100K 1/4W	[M]
R676	ERDS2TJ104T	100K 1/4W	[M]
R677	ERDS2TJ222T	2.2K 1/4W	[M]
R678	ERDS2TJ681T	680 1/4W	[M]
R679	ERDS2TJ391T	390 1/4W	[M]
R682	ERDS2TJ472T	4.7K 1/4W	[M]
R683	ERDS2TJ103T	10K 1/4W	[M]
R684	ERDS2TJ103T	10K 1/4W	[M]
R685	ERDS2TJ103T	10K 1/4W	[M]
R686	ERDS2TJ223T	22K 1/4W	[M]
R688	ERDS2TJ103T	10K 1/4W	[M]
R689	ERDS2TJ101T	100 1/4W	[M]
R690	ERDS2TJ101T	100 1/4W	[M]
R691	ERDS2TJ101T	100 1/4W	[M]
R692	ERDS2TJ101T	100 1/4W	[M]
R693	ERDS2TJ102T	1K 1/4W	[M]
R694	ERDS2TJ152T	1.5K 1/4W	[M]
R695	ERDS2TJ223T	22K 1/4W	[M]
R696	ERDS2TJ470T	47 1/4W	[M]
R697	ERDS2TJ224T	220K 1/4W	[M]
R698	ERDS2TJ331T	330 1/4W	[M]
R699	ERDS2TJ221T	220 1/4W	[M]
R701	ERJ6GEYJ4R7A	4.7 1/10W	[M]
R702	ERJ6GEYJ103A	10K 1/10W	[M]
R704	ERJ6GEYJ102A	1K 1/10W	[M]
R705	ERJ6GEYJ154A	150K 1/10W	[M]
R706	ERJ6GEYJ102A	1K 1/10W	[M]
R707	ERJ6GEYJ393V	39K 1/10W	[M]

Ref. No.	Part No.	Part Name & Description	Remarks
R708	ERJ6GEYJ223A	22K 1/10W	[M]
R709	ERJ6GEYJ683A	68K 1/10W	[M]
R710	ERJ6GEYJ102V	1K 1/10W	[M]
R711	ERJ6GEYJ823A	82K 1/10W	[M]
R712	ERJ8GEYJ221A	220 1/8W	[M]
R714	ERJ6GEY0R00A	0 1/10W	[M]
R715	ERJ6GEYJ102A	1K 1/10W	[M]
R717	ERJ6GEYJ102A	1K 1/10W	[M]
R718	ERJ6GEYJ102A	1K 1/10W	[M]
R721	ERJ6GEYJ101A	100 1/10W	[M]
R723	ERJ6GEYJ682A	6.8K 1/10W	[M]
R724	ERJ6GEYJ183A	18K 1/10W	[M]
R725	ERJ6GEYJ391A	390 1/10W	[M]
R727	ERJ6GEYJ392A	3.9K 1/10W	[M]
R728	ERJ6GEYJ392A	3.9K 1/10W	[M]
R729	ERJ6GEYJ392A	3.9K 1/10W	[M]
R731	ERJ6GEYJ682A	6.8K 1/10W	[M]
R735	ERJ6GEYJ101A	100 1/10W	[M]
R736	ERJ6GEYJ101A	100 1/10W	[M]
R741	ERJ6GEYJ473A	47K 1/10W	[M]
R742	ERJ6GEYJ224A	220K 1/10W	[M]
R744	ERJ6GEYJ124A	120K 1/10W	[M]
R749	ERJ6GEYJ472A	4.7K 1/10W	[M]
R753	ERJ6GEYJ100V	10 1/10W	[M]
R900	ERDS2TJ103T	10K 1/4W	[M]
R901	ERDS2TJ221T	220 1/4W	[M]
R902	ERDS2TJ123T	12K 1/4W	[M]
R903	ERDS2TJ221T	220 1/4W	[M]
R904	ERDS2TJ223T	22K 1/4W	[M]
R905	ERDS2TJ221T	220 1/4W	[M]
R906	ERDS2TJ221T	220 1/4W	[M]
R907	ERDS2TJ104T	100K 1/4W	[M]
R908	ERDS2TJ151T	150 1/4W	[M]
R909	ERDS2TJ221T	220 1/4W	[M]
R910	ERDS2TJ123T	12K 1/4W	[M]
R911	ERDS2TJ473T	47K 1/4W	[M]
R912	ERDS2TJ104T	100K 1/4W	[M]
R913	ERDS2TJ331T	330 1/4W	[M]
R914	ERDS2TJ104T	100K 1/4W	[M]
R915	ERDS2TJ331T	330 1/4W	[M]
R916	ERDS2TJ101T	100 1/4W	[M]
R917	ERDS2TJ681T	680 1/4W	[M]
R918	ERDS2TJ106T	10M 1/4W	[M]
R919	ERDS2TJ101T	100 1/4W	[M]
R920	ERDS2TJ334T	330K 1/4W	[M]
R921	ERDS2TJ562T	5.6K 1/4W	[M]
R922	ERDS2TJ680T	68 1/4W	[M]
R923	ERDS2TJ103T	10K 1/4W	[M]
R924	ERDS2TJ223T	22K 1/4W	[M]
R925	ERDS2TJ680T	68 1/4W	[M]
R926	ERDS2TJ102T	1K 1/4W	[M]
R927	ERDS2TJ103T	10K 1/4W	[M]
R928	ERDS2TJ103T	10K 1/4W	[M]
R929	ERDS2TJ103T	10K 1/4W	[M]
R930	ERDS2TJ103T	10K 1/4W	[M]
R931	ERDS2TJ472T	4.7K 1/4W	[M]
R932	ERDS2TJ223T	22K 1/4W	[M]
R933	ERDS2TJ471T	470 1/4W	[M]
R934	ERDS2TJ472T	4.7K 1/4W	[M]
R935	ERDS2TJ223T	22K 1/4W	[M]
R936	ERDS2TJ103T	10K 1/4W	[M]
R937	ERDS2TJ474T	470K 1/4W	[M]
R938	ERDS2TJ472T	4.7K 1/4W	[M]
R939	ERDS2TJ104T	100K 1/4W	[M]
R940	ERDS2TJ104T	100K 1/4W	[M]
R941	ERDS2TJ104T	100K 1/4W	[M]
R942	ERDS2TJ104T	100K 1/4W	[M]
R943	ERDS2TJ103T	10K 1/4W	[M]
R944	ERDS2TJ103T	10K 1/4W	[M]
R945	ERDS2TJ101T	100 1/4W	[M]
R946	ERDS2TJ101T	100 1/4W	[M]
R947	ERDS2TJ101T	100 1/4W	[M]
R948	ERDS2TJ472T	4.7K 1/4W	[M]
R949	ERDS2TJ331T	330 1/4W	[M]

Ref. No.	Part No.	Part Name & Description	Remarks
R950	ERDS2TJ223T	22K 1/4W	[M]
R951	ERDS2TJ103T	10K 1/4W	[M]
R952	ERDS2TJ331T	330 1/4W	[M]
R952	ERDS2TJ821T	820 1/4W	[M]
R953	ERDS2TJ272T	2.7K 1/4W	[M]
R953	ERDS2TJ393T	39K 1/4W	[M]
R954	ERDS2TJ103T	10K 1/4W	[M]
R955	ERDS2TJ562T	5.6K 1/4W	[M]
R956	ERDS2TJ562T	5.6K 1/4W	[M]
R957	ERDS2TJ562T	5.6K 1/4W	[M]
R958	ERDS2TJ562T	5.6K 1/4W	[M]
R959	ERDS2TJ103T	10K 1/4W	[M]
R960	ERDS2TJ102T	1K 1/4W	[M]
R961	ERDS2TJ103T	10K 1/4W	[M]
R963	ERDS2TJ561T	560 1/4W	[M]GC
R964	ERDS2TJ331T	330 1/4W	[M]
R965	ERDS2TJ102T	1K 1/4W	[M]
R966	ERDS2TJ101T	100 1/4W	[M]
R967	ERDS2TJ101T	100 1/4W	[M]
R969	ERDS2TJ104T	100K 1/4W	[M]
R970	ERDS2TJ103T	10K 1/4W	[M]
R971	ERDS2TJ103T	10K 1/4W	[M]
R972	ERDS2TJ103T	10K 1/4W	[M]
R972	ERDS2TJ821T	820 1/4W	[M]
R973	ERDS2TJ101T	100 1/4W	[M]
R973	ERDS2TJ393T	39K 1/4W	[M]
R976	ERDS2TJ103T	10K 1/4W	[M]
R977	ERDS2TJ103T	10K 1/4W	[M]GC
R978	ERDS2TJ102T	1K 1/4W	[M]
R979	RSFMB40KT-L	FUSE PROTECTOR	[M] △
R980	ERDS1FVJ180T	18 1/2W	[M]GN △
R980	ERDS2TJ150T	15 1/4W	[M]GC △
R981	ERDS1FVJ180T	18 1/2W	[M]GN △
R981	ERDS1FVJ220T	22 1/2W	[M]GC △
R982	ERDS2TJ824T	820K 1/4W	[M]GC
R983	ERDS2TJ122T	1.2K 1/4W	[M]GC
R983	ERDS2TJ222T	2.2K 1/4W	[M]GN
R984	ERDS2TJ102T	1K 1/4W	[M]
R984	ERDS2TJ151T	150 1/4W	[M]GN
R984	ERDS2TJ152T	1.5K 1/4W	[M]GC
R985	ERDS1FVJ180T	18 1/2W	[M]GC △
R985	ERDS1FVJ220T	22 1/2W	[M]GN △
R986	ERDS2TJ150T	15 1/4W	[M]GC
R988	RSFMB40KT-L	FUSE PROTECTOR	[M] △
R1001	ERJ6GEYJ1R0A	1 1/10W	[M]
R1003	ERJ6GEYJ103V	10K 1/10W	[M]
R1004	ERJ6GEYJ152V	1.5K 1/10W	[M]
R1005	ERJ6GEYJ472V	4.7K 1/10W	[M]
R1006	ERJ6GEYJ102V	1K 1/10W	[M]
R1007	ERD25FVJ4R7T	4.7 1/4W	[M]
R1008	ERJ6GEYJ223V	22K 1/10W	[M]
R1009	ERJ6GEYJ183V	18K 1/10W	[M]
R1010	ERJ6GEYJ183V	18K 1/10W	[M]
R1011	ERJ6GEYJ103V	10K 1/10W	[M]
R1012	ERJ6GEYJ472V	4.7K 1/10W	[M]
R1013	ERJ6GEYJ472V	4.7K 1/10W	[M]
R1014	ERJ6GEYJ472V	4.7K 1/10W	[M]
R1015	ERJ6GEYJ470V	47 1/10W	[M]
R1016	ERJ6GEYJ470V	47 1/10W	[M]
R1017	ERJ6GEYJ822V	8.2K 1/10W	[M]
R1018	ERJ6GEYJ392V	3.9K 1/10W	[M]
R1019	ERJ6GEYJ392V	3.9K 1/10W	[M]
R1020	ERJ6GEYJ470V	47 1/10W	[M]
R1022	ERJ6GEYJ103V	10K 1/10W	[M]
R1024	ERJ6GEYJ563V	56K 1/10W	[M]
R1026	ERJ6GEYJ102V	1K 1/10W	[M]
R1027	ERJ6GEYJ104V	100K 1/10W	[M]
R1028	ERJ6GEYJ822V	8.2K 1/10W	[M]
R1029	ERJ6GEYJ475V	4.7M 1/10W	[M]
R1030	ERJ6GEYJ101V	100 1/10W	[M]
R1031	ERJ6GEYJ273V	27K 1/10W	[M]
R1032	ERJ6GEYJ103V	10K 1/10W	[M]
R1035	ERJ6GEYJ103V	10K 1/10W	[M]
R1036	ERJ6GEYJ470V	47 1/10W	[M]

Ref. No.	Part No.	Part Name & Description	Remarks
R1037	ERJ6GEYJ104V	100K 1/10W	[M]
R1038	ERJ6GEYJ472V	4.7K 1/10W	[M]
R1039	ERJ6GEYJ153V	15K 1/10W	[M]
R1040	ERJ6GEYJ563V	56K 1/10W	[M]
R1045	ERJ6GEYJ104V	100K 1/10W	[M]
R1046	ERJ6GEYJ104V	100K 1/10W	[M]
R1047	ERJ6GEYJ102V	1K 1/10W	[M]
R1048	ERJ6GEYJ102V	1K 1/10W	[M]
R1049	ERJ6GEYJ105V	1M 1/10W	[M]
R1050	ERJ6GEYJ105V	1M 1/10W	[M]
R1051	ERJ6GEYJ221V	220 1/10W	[M]
R1052	ERJ6GEYJ221V	220 1/10W	[M]
R1053	ERJ6GEYJ681V	680 1/10W	[M]
R1054	ERJ6GEYJ681V	680 1/10W	[M]
R1055	ERJ6GEYJ222V	2.2K 1/10W	[M]
R1056	ERJ6GEYJ221V	220 1/10W	[M]
R1057	ERJ6GEYJ222V	2.2K 1/10W	[M]
R1058	ERJ6GEYJ272V	2.7K 1/10W	[M]
R1059	ERJ6GEYJ103V	10K 1/10W	[M]
R1060	ERJ6GEYJ391V	390 1/10W	[M]
R1061	ERJ6GEYJ2R7V	2.7 1/10W	[M]
R1062	ERJ6GEYJ2R7V	2.7 1/10W	[M]
R1063	ERJ6GEYJ102V	1K 1/10W	[M]
R1064	ERJ6GEYJ102V	1K 1/10W	[M]
R1065	ERJ6GEYJ102V	1K 1/10W	[M]
R1066	ERJ6GEYJ102V	1K 1/10W	[M]
R1067	ERJ6GEYJ153V	15K 1/10W	[M]
R1068	ERJ6GEYJ153V	15K 1/10W	[M]
R1069	ERJ6GEYJ682V	6.8K 1/10W	[M]
R1070	ERJ6GEYJ103V	10K 1/10W	[M]
R1071	ERJ6GEYJ103V	10K 1/10W	[M]
R1072	ERJ6GEYJ331V	330 1/10W	[M]
R1073	ERJ6GEYJ682V	6.8K 1/10W	[M]
R1074	ERJ6GEYJ823V	82K 1/10W	[M]
R1075	ERJ6GEYJ222V	2.2K 1/10W	[M]
R1076	ERJ6GEYJ222V	2.2K 1/10W	[M]
R1077	ERJ6GEYJ393V	39K 1/10W	[M]
R1078	ERJ6GEYJ682V	6.8K 1/10W	[M]
R1079	ERJ6GEYJ472V	4.7K 1/10W	[M]
R1080	ERJ6GEYJ472V	4.7K 1/10W	[M]
R1081	ERJ6GEYJ102V	1K 1/10W	[M]
R1082	ERJ6GEYJ393V	39K 1/10W	[M]
R1083	ERJ6GEYJ822V	8.2K 1/10W	[M]
R1084	ERJ6GEYJ222V	2.2K 1/10W	[M]
R1085	ERJ6GEYJ473V	47K 1/10W	[M]
R1086	ERJ6GEYJ222V	2.2K 1/10W	[M]
R1087	ERJ6GEYJ473V	47K 1/10W	[M]
R1088	ERJ6GEYJ223V	22K 1/10W	[M]
R1089	ERJ6GEYJ223V	22K 1/10W	[M]
R1090	ERJ6GEYJ331V	330 1/10W	[M]
R1091	ERJ6GEYJ222V	2.2K 1/10W	[M]
R1092	ERJ6GEYJ222V	2.2K 1/10W	[M]
R1093	ERJ6GEYJ102V	1K 1/10W	[M]
R1094	ERJ6GEYJ102V	1K 1/10W	[M]
R1095	ERJ6GEYJ104V	100K 1/10W	[M]
R1096	ERJ6GEYJ104V	100K 1/10W	[M]
R1097	ERJ6GEYJ473V	47K 1/10W	[M]
R1098	ERJ6GEYJ473V	47K 1/10W	[M]
		CAPACITORS	
C1	ECBT1H5R6KC5	5.6P 50V	[M]
C1	ECEA1CKA101B	100 16V	[M]
C2	ECBT1E103ZF5	0.01 25V	[M]
C2	RCBS1H102KBY	1000P 50V	[M]
C3	ECBT1H2R2KC5	2.2P 50V	[M]
C4	ECBT1H181KB5	180P 50V	[M]
C5	ECBT1H5R6KC5	5.6P 50V	[M]
C6	ECBT1H3R3KC5	3.3P 50V	[M]
C7	ECBT1H4R7KC5	4.7P 50V	[M]
C8	ECBT1H3R3KC5	3.3P 50V	[M]
C9	ECBT1H2R2KC5	2.2P 50V	[M]
C10	ECBT1H180JC5	18P 50V	[M]
C11	RCBS1H102KBY	1000P 50V	[M]

Ref. No.	Part No.	Part Name & Description	Remarks
C101	ECUV1H103KBN	0.01 50V	[M]
C102	ECEALCKA100B	10 16V	[M]
C103	ECUV1H103KBN	0.01 50V	[M]
C104	ECUV1H102KBN	1000P 50V	[M]
C105	ECEA0JKA470B	47 6.3V	[M]GC
C106	ECUV1H103KBN	0.01 50V	[M]
C107	ECUV1E473ZFN	0.047 25V	[M]GN
C107	ECUV1H472KBN	4700P 50V	[M]GC
C108	ECUV1H080DCN	8P 50V	[M]GN
C109	ECUV1H102KBN	1000P 50V	[M]
C110	ECUV1H103KBN	0.01 50V	[M]
C111	ECEALKA4R7B	4.7 25V	[M]
C112	ECUV1H103KBN	0.01 50V	[M]
C113	ECUV1H102KBN	1000P 50V	[M]
C114	ECEALHKA3R3B	3.3 50V	[M]
C115	ECEALKA4R7B	4.7 25V	[M]
C116	ECUV1H333KBN	0.033 50V	[M]GC
C116	ECUVNE333KBN	0.033 25V	[M]GN
C117	ECUV1H103KBN	0.01 50V	[M]
C118	ECUV1H103KBN	0.01 50V	[M]
C119	ECQP2A681JZT	680P 100V	[M]
C120	ECEALCKA100B	10 16V	[M]
C121	ECEALHKAR47B	0.47 50V	[M]
C122	ECEALHKA010B	1 50V	[M]
C123	ECEALHKA010B	1 50V	[M]
C124	ECUV1H101KCN	100P 50V	[M]
C125	ECEALCKA220B	22 16V	[M]
C126	ECUVNC105ZFN	10 16V	[M]
C127	ECEALCKA220B	22 16V	[M]
C128	ECUV1H102KBN	1000P 50V	[M]GC
C129	ECEA0JKA101B	100 6.3V	[M]
C130	ECEA0JKA101B	100 6.3V	[M]
C131	ECUV1H151KCN	150P 50V	[M]
C132	ECUV1H102KBN	1000P 50V	[M]
C133	ECUV1H270JCN	27P 50V	[M]
C134	ECUV1H270JCN	27P 50V	[M]
C135	ECUV1H103KBN	0.01 50V	[M]GC
C136	ECUV1H102KBN	1000P 50V	[M]
C137	ECUV1H332KBN	3300P 50V	[M]
C138	ECUV1H103KBN	0.01 50V	[M]
C139	ECEALKA4R7B	4.7 25V	[M]
C141	ECEALHKA010B	1 50V	[M]
C142	ECEALHKA010B	1 50V	[M]
C143	ECUV1H472KBN	4700P 50V	[M]GC
C143	ECUV1H682KBN	6800P 50V	[M]GN
C144	ECUV1H472KBN	4700P 50V	[M]GC
C144	ECUV1H682KBN	6800P 50V	[M]GN
C147	ECUV1H102KBN	1000P 50V	[M]
C148	ECUV1H103KBN	0.01 50V	[M]
C149	ECUV1E104ZFN	0.1 25V	[M]
C152	ECUV1H220JCN	22P 50V	[M]GC
C153	ECUV1H180JCN	18P 50V	[M]GC
C154	ECKR1H473ZF5	0.047 50V	[M]GC
C155	ECUV1E473ZFN	0.047 25V	[M]GC
C156	ECQP2A272JZT	2700P 100V	[M]GC
C158	ECUV1H102KBN	1000P 50V	[M]GC
C159	ECUV1H102KBN	1000P 50V	[M]GC
C160	ECUV1H103KBN	0.01 50V	[M]GC
C201	ECUZ1H101JCN	100P 50V	[M]
C202	ECUZ1H101JCN	100P 50V	[M]
C204	ECUV1H221KBN	220P 50V	[M]
C207	ECEALHKA010B	1 50V	[M]
C208	ECUZ1E563KBN	0.056 25V	[M]
C209	ECEALHKAR15B	0.15 50V	[M]
C210	ECUZ1E223KBN	0.022 25V	[M]
C211	ECUZNC393KBN	0.039 16V	[M]
C212	ECUZ1E223KBN	0.022 25V	[M]
C213	ECUZ1H332KBN	3300P 50V	[M]
C214	ECUZ1H222KBN	2200P 50V	[M]
C215	ECUZ1H272KBN	2700P 50V	[M]
C216	ECUZ1H152KBN	1500P 50V	[M]
C217	ECUZ1C333KBN	0.033 16V	[M]
C218	ECEALHKAR15B	0.15 50V	[M]
C220	ECUZ1H102KBN	1000P 50V	[M]

Ref. No.	Part No.	Part Name & Description	Remarks
C221	ECUZ1E563KBN	0.056 25V	[M]
C222	ECUZ1H471KBN	470P 50V	[M]
C223	ECEALHKA220B	22 50V	[M]
C224	ECEALHKA3R3B	3.3 50V	[M]
C225	ECEALHKA3R3B	3.3 50V	[M]
C226	ECUZNC683KBN	0.068 16V	[M]
C227	ECUV1H681KBN	680P 50V	[M]
C228	ECEALCKA100B	10 16V	[M]
C229	ECUZ1H101JCN	100P 50V	[M]
C230	ECUZ1H470JCN	47P 50V	[M]
C232	ECUV1H332KBN	3300P 50V	[M]
C233	ECEALHKA100B	10 50V	[M]
C236	ECUZ1C474ZFN	0.47 16V	[M]
C237	ECUZ1H102KBN	1000P 50V	[M]
C238	ECEALHKAR22B	0.22 50V	[M]
C242	ECEALHKA010B	1 50V	[M]
C300	ECUZ1C103KBN	0.01 16V	[M]
C301	ECUZ1H102KBN	1000P 50V	[M]
C304	ECEALAM331B	330 10V	[M]
C305	ECUZ1H152KBN	1500P 50V	[M]
C306	ECEALHKA0R1B	0.1 50V	[M]
C307	ECUZ1H102KBN	1000P 50V	[M]
C308	ECUZ1E473ZFN	0.047 25V	[M]
C312	ECUZ1E104ZFN	0.1 25V	[M]
C313	ECUZ1E104ZFN	0.1 25V	[M]
C314	ECUV1H151KCN	150P 50V	[M]
C315	ECUV1H151KCN	150P 50V	[M]
C316	ECUV1H151KCN	150P 50V	[M]
C317	ECEALHKA010B	1 50V	[M]
C318	ECUZ1C103KBN	0.01 16V	[M]
C320	ECUZ1C103KBN	0.01 16V	[M]
C329	ECUZ1E104ZFN	0.1 25V	[M]
C330	ECEALHKA010B	1 50V	[M]
C331	ECEALHKA4R7B	4.7 50V	[M]
C401	ECUZ1H101JCN	100P 50V	[M]
C402	ECUZ1H101JCN	100P 50V	[M]
C404	ECUV1H221KBN	220P 50V	[M]
C407	ECEALHKA010B	1 50V	[M]
C408	ECUZ1E563KBN	0.056 25V	[M]
C409	ECEALHKAR15B	0.15 50V	[M]
C410	ECUZ1E223KBN	0.022 25V	[M]
C411	ECUZNC393KBN	0.039 16V	[M]
C412	ECUZ1E223KBN	0.022 25V	[M]
C413	ECUV1H332KBN	3300P 50V	[M]
C414	ECUZ1H222KBN	2200P 50V	[M]
C415	ECUZ1H272KBN	2700P 50V	[M]
C416	ECUZ1H152KBN	1500P 50V	[M]
C417	ECUZ1C333KBN	0.033 16V	[M]
C418	ECEALHKAR15B	0.15 50V	[M]
C420	ECUZ1H102KBN	1000P 50V	[M]
C421	ECUZ1E563KBN	0.056 25V	[M]
C422	ECUZ1H471KBN	470P 50V	[M]
C423	ECEALHKA220B	22 50V	[M]
C424	ECEALHKA3R3B	3.3 50V	[M]
C425	ECEALHKA3R3B	3.3 50V	[M]
C426	ECUZNC683KBN	0.068 16V	[M]
C427	ECUV1H681KBN	680P 50V	[M]
C428	ECEALCKA100B	10 16V	[M]
C429	ECUZ1H101JCN	100P 50V	[M]
C430	ECUZ1H470JCN	47P 50V	[M]
C432	ECUV1H332KBN	3300P 50V	[M]
C433	ECEALHKA100B	10 50V	[M]
C437	ECUZ1H102KBN	1000P 50V	[M]
C438	ECEALHKAR22B	0.22 50V	[M]
C442	ECEALHKA010B	1 50V	[M]
C500	ECEALHKA3R3B	3.3 50V	[M]
C501	ECEALHKA3R3B	3.3 50V	[M]
C502	ECEA2AM100B	10 100V	[M]
C503	ECKR1H103ZF5	0.01 50V	[M]
C505	ECEALHKA010B	1 50V	[M]
C506	ECBT1H102KB5	1000P 50V	[M]
C508	ECBT1H331KB5	330P 50V	[M]
C509	ECEALHKA010B	1 50V	[M]
C510	ECBT1H331KB5	330P 50V	[M]

Ref. No.	Part No.	Part Name & Description	Remarks
C511	ECBT1H102KB5	1000P 50V	[M]
C512	ECKR1H103ZF5	0.01 50V	[M]
C513	ECEA1HM470B	47 50V	[M]
C514	ECBT1H150J5	15P 50V	[M]
C517	ECEA2AU100B	10 100V	[M]
C518	ECEA1HKA010B	1 50V	[M]
C519	ECBT1H150J5	15P 50V	[M]
C520	ECEA2AM100B	10 100V	[M]
C521	ECEA1JM101B	100 63V	[M]
C522	ECEA1HKA100B	10 50V	[M]
C523	ECKR1H103ZF5	0.01 50V	[M]
C524	ECEA2AU100B	10 100V	[M]
C525	ECEA1EM101B	100 25V	[M]
C527	ECEA1EM101B	100 25V	[M]
C528	ECKR1H103ZF5	0.01 50V	[M]
C529	ECEA1HM470B	47 50V	[M]
C530	ECEA1VM101B	100 35V	[M]
C531	ECQV1H474JZ3	0.47 50V	[M]
C533	ECKR2H103ZF5	0.01 500V	[M]
C534	ECKR2H103ZF5	0.01 500V	[M]
C535	ECKR2H103ZF5	0.01 500V	[M]
C536	RCEA1E222B-S	2200P 25V	[M] △
C537	ECEA0JKA221B	220 6.3V	[M]
C538	ECKR2H103ZF5	0.01 500V	[M]
C539	ECBT1H102KB5	1000P 50V	[M]
C540	ECEA2AU100B	10 100V	[M]
C541	ECBT1H104ZF5	0.1 50V	[M] △
C542	ECBT1H104ZF5	0.1 50V	[M] △
C543	ECBT1H104ZF5	0.1 50V	[M] △
C544	ECBT1H104ZF5	0.1 50V	[M] △
C545	RCEA1H222B-S	2200P 50V	[M] △
C546	RCEA1H222B-S	2200P 50V	[M] △
C547	ECEA1JM101B	100 63V	[M]
C548	ECEA1EM102B	1000 25V	[M]
C550	ECEA1HM470B	47 50V	[M]
C551	ECKR2H103ZF5	0.01 500V	[M]
C552	ECKR2H103ZF5	0.01 500V	[M]
C553	ECEA1HKAR15B	0.15 50V	[M]
C554	ECEA1HKAR15B	0.15 50V	[M]
C555	ECEA1VM102B	1000 35V	[M]
C556	ECQV1H184JZ3	0.18 50V	[M] △
C600	ECEA1HKAR33B	0.33 50V	[M]GC
C602	ECBT1H473ZF5	0.047 50V	[M]GC
C603	ECEA1HKA010B	1 50V	[M]GC
C604	ECBT1E223ZF5	0.022 25V	[M]
C605	ECBT1H102KB5	1000P 50V	[M]GC
C606	ECBT1E223ZF5	0.022 25V	[M]
C607	ECBT1H101KB5	100P 50V	[M]GC
C608	ECBT1H102KB5	1000P 50V	[M]GC
C609	ECEA1HKA010B	1 50V	[M]GC
C610	ECEA1AKA101B	100 10V	[M]GC
C611	ECBT1H104ZF5	0.1 50V	[M]
C612	ECEA1VKA220B	22 35V	[M]
C613	ECBT1H681KB5	680P 50V	[M]
C614	ECBT1H681KB5	680P 50V	[M]
C615	ECBT1H101KB5	100P 50V	[M]
C616	ECBT1H101KB5	100P 50V	[M]
C622	ECBT1E103ZF5	0.01 25V	[M]
C623	ECBT1H102KB5	1000P 50V	[M]
C624	ECEA0JKA101B	100 6.3V	[M]
C625	RCEA0J102B-S	1000P 6.3V	[M]
C626	ECBT1H102KB5	1000P 50V	[M]
C627	ECBT1E103ZF5	0.01 25V	[M]
C628	ECEA1AKA220B	22 10V	[M]
C629	ECBT1H331KB5	330P 50V	[M]
C630	ECBT1H561KB5	560P 50V	[M]
C631	ECBT1H561KB5	560P 50V	[M]
C634	ECEA1VKA220B	22 35V	[M]
C635	ECBT1H561KB5	560P 50V	[M]
C636	ECBT1H561KB5	560P 50V	[M]
C637	ECBT1H561KB5	560P 50V	[M]
C638	ECBT1H561KB5	560P 50V	[M]
C639	ECBT1H101KB5	100P 50V	[M]
C642	ECEA1CKA100B	10 16V	[M]

Ref. No.	Part No.	Part Name & Description	Remarks
C643	ECBT1H561KB5	560P 50V	[M]
C644	ECBT1H561KB5	560P 50V	[M]
C645	ECBT1H561KB5	560P 50V	[M]
C646	ECBT1H561KB5	560P 50V	[M]
C647	ECBT1E103ZF5	0.01 25V	[M]
C648	ECEA1HKA0R1B	0.1 50V	[M]
C649	ECEA1CKA100B	10 16V	[M]
C650	ECBT1E103ZF5	0.01 25V	[M]
C651	ECBT1H150JC5	15P 50V	[M]
C652	ECBT1H101KB5	100P 50V	[M]
C653	ECEA1AM331B	330 10V	[M]
C654	ECBT1H180JC5	18P 50V	[M]
C655	ECBT1H101KB5	100P 50V	[M]
C656	ECBT1H680J5	68P 50V	[M]
C657	ECBT1H680J5	68P 50V	[M]
C658	ECEA1HKA010B	1 50V	[M]
C659	ECBT1H560J5	56P 50V	[M]
C660	ECEA1HKA3R3B	3.3 50V	[M]
C661	ECBT1H560J5	56P 50V	[M]
C662	ECEA1HKA2R2B	2.2 50V	[M]
C663	ECBT1H102KB5	1000P 50V	[M]
C664	ECBT1H102KB5	1000P 50V	[M]
C665	ECBT1H561KB5	560P 50V	[M]
C666	ECBT1E223ZF5	0.022 25V	[M]GC
C667	ECBT1E103ZF5	0.01 25V	[M]
C668	ECEA1HKA0R1B	0.1 50V	[M]
C669	ECEA1HKA0R1B	0.1 50V	[M]
C670	ECBT1H561KB5	560P 50V	[M]
C671	ECBT1H104ZF5	0.1 50V	[M]
C674	ECEA1HKA4R7B	4.7 50V	[M]
C686	ECBT1C103MS5	0.01 16V	[M]GC
C700	ECBT1H102KB5	1000P 50V	[M]GC
C701	ECEA0JKA330I	33 6.3V	[M]
C701	ECUV1H104ZFN	0.1 50V	[M]GC
C702	ECUZ1E104MBN	0.1 25V	[M]
C703	ECEA0JKA101I	100 6.3V	[M]
C704	ECUZ1E104MBN	0.1 25V	[M]
C706	ECUZ1H272KBN	2700P 50V	[M]
C707	ECUZ1E273KBN	0.027 25V	[M]
C710	ECUZ1H121KCN	120P 50V	[M]
C711	ECUZ1E104ZFN	0.1 25V	[M]
C712	ECUZ1E104ZFN	0.1 25V	[M]
C713	ECUZ1E104MBN	0.1 25V	[M]
C714	ECEA0JKA101I	100 6.3V	[M]
C715	ECUZ1H272KBN	2700P 50V	[M]
C716	ECUZ1H821KBN	820P 50V	[M]
C717	ECUZ1E104ZFN	0.1 25V	[M]
C718	ECUZ1C224KBN	0.22 16V	[M]
C721	ECUZ1H100DCN	10P 50V	[M]
C722	ECUZ1H100DCN	10P 50V	[M]
C723	ECEA1AKA221I	220 10V	[M]
C724	ECUZ1E104MBN	0.1 25V	[M]
C725	ECUZ1H102KBN	1000P 50V	[M]
C726	ECUZ1H102KBN	1000P 50V	[M]
C727	ECA1HAK010XI	1 50V	[M]
C728	ECA1HAK010XI	1 50V	[M]
C730	ECUZ1E104ZFN	0.1 25V	[M]
C731	ECEA0JKA221I	220 6.3V	[M]
C732	ECEA0JKA221I	220 6.3V	[M]
C733	ECUZ1E104MBN	0.1 25V	[M]
C734	ECEA1AKA221I	220 10V	[M]
C735	ECUZ1E104ZFN	0.1 25V	[M]
C736	ECUZ1E104ZFN	0.1 25V	[M]
C737	ECUZ1E104ZFN	0.1 25V	[M]
C738	ECUZ1H103KBN	0.01 50V	[M]
C739	ECUZ1H152KBN	1500P 50V	[M]
C742	ECUZ1E273KBN	0.027 25V	[M]
C743	ECUZ1E104ZFN	0.1 25V	[M]
C744	ECUZ1E822KBN	8200P 25V	[M]
C745	ECUZ1H102KBN	1000P 50V	[M]
C747	ECUZ1H181KCN	180P 50V	[M]
C749	ECUZ1H222KBN	2200P 50V	[M]
C750	ECUZ1E104MBN	0.1 25V	[M]
C751	ECUZ1E104MBN	0.1 25V	[M]

Ref. No.	Part No.	Part Name & Description	Remarks
C752	ECUZ1H102KBN	1000P 50V	[M]
C753	ECUZ1H471KBM	470P 50V	[M]
C754	ECUZ1H471KBN	470P 50V	[M]
C900	ECBT1H101KB5	100P 50V	[M]
C901	ECBT1H101KB5	100P 50V	[M]
C902	ECBT1H104ZF5	0.1 50V	[M]
C975	ECEA1VKA4R7B	4.7 35V	[M]GC
C976	RCEA1C102B-S	1000P 16V	[M]GC
C977	RCEA1C102B-S	1000P 16V	[M]GC △
C978	ECKR1H103ZF5	0.01 50V	[M] △
C979	ECKR1H102ZF5	1000P 50V	[M]GC
C980	ECKR1H103ZF5	0.01 50V	[M]
C981	ECEA1AKA470B	47 10V	[M]GC
C981	ECEA1EKA220B	22 25V	[M]GN
C984	RCEA1C102B-S	1000P 16V	[M]GN △
C1001	ECUZ1H103KBN	0.01 50V	[M]
C1002	ECEA1HKN2R2B	2.2 50V	[M]
C1003	ECQP1152JZF	1500P 100V	[M]
C1006	ECEA1HKA010B	1 50V	[M]
C1007	ECQP2A472JZF	4700P 100V	[M]
C1008	ECEA1HKA010B	1 50V	[M]
C1009	ECEA1AKA470B	47 10V	[M]
C1010	ECEA1EM101B	100 25V	[M]
C1011	ECQV1H473JZ3	0.047 50V	[M]
C1012	ECUZ1H102KBN	1000P 50V	[M]
C1013	ECUZ1H102KBN	1000P 50V	[M]
C1014	ECUZ1H102KBN	1000P 50V	[M]
C1015	ECUZ1H102KBN	1000P 50V	[M]
C1016	ECUZ1H222KBN	2200P 50V	[M]
C1017	ECUZ1H222KBN	2200P 50V	[M]
C1018	ECUZ1H103KBN	0.01 50V	[M]
C1019	ECUZ1H102KBN	1000P 50V	[M]
C1020	ECUZ1H471KBN	470P 50V	[M]
C1021	ECUZ1H471KBN	470P 50V	[M]
C1022	ECUZ1H102KBN	1000P 50V	[M]
C1023	ECUZ1H102KBN	1000P 50V	[M]
C1026	ECEA0JKA470B	47 6.3V	[M]
C1027	ECUZ1H102KBN	1000P 50V	[M]
C1030	ECEA1AKA101B	100 10V	[M]
C1031	ECEA1AKA101B	100 10V	[M]
C1032	ECFR1C183KR	0.018 16V	[M]
C1033	ECFR1C183KR	0.018 16V	[M]
C1034	ECEA1HKA3R3B	3.3 50V	[M]
C1035	ECEA1HKA3R3B	3.3 50V	[M]
C1036	ECUV1H333KBN	0.033 50V	[M]
C1037	ECEA1HKA3R3B	3.3 50V	[M]
C1038	ECUZ1H221KBN	220P 50V	[M]
C1039	ECUZ1H221KBN	220P 50V	[M]
C1040	ECEA1CKA100B	10 16V	[M]
C1041	ECEA1CKA100B	10 16V	[M]
C1042	ECEA1CKA220B	22 16V	[M]
C1043	ECEA1HKA4R7B	4.7 50V	[M]
C1044	ECEA1AKA330B	33 10V	[M]
C1045	ECEA1AKA220B	22 10V	[M]
C1046	ECEA1AKA221Q	220 10V	[M]
C1047	ECEA1HKA010B	1 50V	[M]
C1048	ECEA1HKA010B	1 50V	[M]
C1049	ECUZ1H102KBN	1000P 50V	[M]
C1050	ECUZ1H102KBN	1000P 50V	[M]
C1051	ECEA1HKA010B	1 50V	[M]
C1052	ECEA1HKA010B	1 50V	[M]
C1053	ECEA1CM221B	220 16V	[M]
C1054	ECEA1HKA3R3B	3.3 50V	[M]
C1055	ECEA1HKA0R1B	0.1 50V	[M]
C1056	ECUZ1H103KBN	0.01 50V	[M]
C1057	ECEA1HKA3R3B	3.3 50V	[M]
C1058	ECUZ1H470JCN	47P 50V	[M]
C1059	ECUZ1H101KBN	100P 50V	[M]
C1060	ECUZ1H472KBN	4700P 50V	[M]
C1061	ECUZ1H101KBN	100P 50V	[M]
C1062	ECUV1E104ZFN	0.1 25V	[M]
C1063	ECUV1E104ZFN	0.1 25V	[M]
C1064	ECEA1HKA3R3B	3.3 50V	[M]
C1065	ECUZ1H103KBN	0.01 50V	[M]

Ref. No.	Part No.	Part Name & Description	Remarks
		CHIP JUMPER	
RJ701	ERJ6GEY0R00A	0 1/10W	[M]
RJ702	ERJ8GEY0R00A	0 1/8W	[M]
RJ703	ERJ8GEY0R00A	0 1/8W	[M]
RJ704	ERJ8GEY0R00A	0 1/8W	[M]
RJ707	ERJ8GEY0R00A	0 1/8W	[M]
RJ708	ERJ8GEY0R00A	0 1/8W	[M]
RJ709	ERJ8GEY0R00A	0 1/8W	[M]
RJ710	ERJ8GEY0R00A	0 1/8W	[M]
RJ712	ERJ8GEY0R00A	0 1/8W	[M]
RJ715	ERJ6GEY0R00A	0 1/10W	[M]
RJ716	ERJ6GEY0R00A	0 1/10W	[M]
RJ721	ERJ6GEY0R00A	0 1/10W	[M]
RJ722	ERJ6GEY0R00A	0 1/10W	[M]
RJ724	ERJ6GEY0R00A	0 1/10W	[M]
RJ727	ERJ6GEY0R00A	0 1/10W	[M]
RJ728	ERJ6GEY0R00A	0 1/10W	[M]
RJ731	ERJ6GEY0R00A	0 1/10W	[M]
RJ732	ERJ6GEY0R00A	0 1/10W	[M]
RJ734	ERJ6GEY0R00A	0 1/10W	[M]
RJ750	ERJ6GEY0R00A	0 1/10W	[M]
		TEST JUMPER	
TJ701	EYF8CU	TEST JUMEP	[M]

19.5. Packing Materials & Accessories Parts List

Ref. No.	Part No.	Part Name & Description	Remarks
		PACKING MATERIALS	
P1	RPGX0599	PACKING CASE	[MAVD]
P2	RPNX0118	POLYFOAM	[MAVD]
P3	RPFX0007	MIRAMAT BAG	[M]
		ACCESSORIES	
A1	EUR648200	REMOTE CONTROL	[M]
A1-1	UR64EC2337A	R/C BATTERY	[M]

Ref. No.	Part No.	Part Name & Description	Remarks
A2	RJA0043-1C	AC CORD	[MAVD]EG E △
A2	RJA0044-3C	AC CORD	[MAVD]EB △
A3	RQT5261-E	O/I BOOK	[MAVD]E
A3	RQT5262-R	O/I BOOK	[MAVD]E
A3	RQT5263-D	O/I BOOK	[MAVD]EG
A3	RQT5264-H	O/I BOOK	[MAVD]EG
A3	RQT5265-B	O/I BOOK	[M]EB
A4	RSA0007	FM ANTENNA	[M]
A5	RSA0029	AM LOOP ANT	[M]
A6	SJP9009	ANT ADAPTER	[M]EB

19.6. Packaging

