

SHARP SERVICE MANUAL

S9614R939PHW/



MICROWAVE OVEN WITH GRILL AND CONVECTION

MODELS **R-939(BK)**
 R-939(IN)
 R-939(W)

In interests of user-safety the oven should be restored to its original condition and only parts identical to those specified should be used.

CONTENTS

CHAPTER 1. BEFORE SERVICING

CHAPTER 2. WARNING TO SERVICE PERSONNEL

CHAPTER 3. PRODUCT SPECIFICATIONS

CHAPTER 4. APPEARANCE VIEW

CHAPTER 5. OPERATION SEQUENCE

CHAPTER 6. FUNCTION OF IMPORTANT COMPONENTS

CHAPTER 7. TROUBLESHOOTING GUIDE

CHAPTER 8. TEST PROCEDURES

CHAPTER 9. TOUCH CONTROL PANEL ASSEMBLY

CHAPTER 10. PRECAUTIONS FOR USING LEAD-FREE SOLDER

CHAPTER 11. COMPONENT REPLACEMENT AND ADJUSTMENT PROCEDURE

CHAPTER 12. MICROWAVE MEASUREMENT

CHAPTER 13. TEST DATA AT A GLANCE

CHAPTER 14. CIRCUIT DIAGRAMS

Parts List

CONTENTS

CHAPTER 1. BEFORE SERVICING

- [1] GENERAL IMPORTANT INFORMATION 1-1
- [2] WARNING 1-1
- [3] CAUTION MICROWAVE RADIATION 1-2

CHAPTER 2. WARNING TO SERVICE PERSONNEL

CHAPTER 3. PRODUCT SPECIFICATIONS

CHAPTER 4. APPEARANCE VIEW

- [1] OVEN 4-1
- [2] TOUCH CONTROL PANEL 4-1

CHAPTER 5. OPERATION SEQUENCE

- [1] OFF CONDITION 5-1
- [2] MICROWAVE COOKING CONDITION 5-1
- [3] GRILL COOKING CONDITION 5-2
- [4] CONVECTION COOKING CONDITION 5-2
- [5] DUAL COOKING CONDITION 5-2
- [6] ON/OFF TIME RATIO 5-3
- [7] AUTOMATIC COOKING 5-3
- [8] POWER OUTPUT REDUCTION 5-3
- [9] FAN MOTOR OPERATION 5-3
- [10] CONVECTION MOTOR OPERATION 5-3

CHAPTER 6. FUNCTION OF IMPORTANT COMPONENTS

- [1] DOOR OPEN MECHANISM 6-1
- [2] MONITORED LATCH SWITCH (SW1) 6-1
- [3] STOP SWITCH (SW2) 6-1
- [4] MONITOR SWITCH (SW3) 6-1
- [5] FUSE (F1) 20A 250V 6-1
- [6] FUSE (F2) F8A 250V (NOISE FILTER) 6-1
- [7] TC TRANSFORMER 6-1
- [8] THERMAL CUT-OUT (TC1) 125C (MG) 6-1
- [9] THERMAL CUT-OUT (TC2) 170C (GRILL) 6-1
- [10] THERMAL CUT-OUT (TC3) 170C (CONV.) 6-1
- [11] ASYMMETRIC RECTIFIER 6-1
- [12] NOISE FILTER 6-2
- [13] TURNTABLE MOTOR (TTM) 6-2
- [14] FAN MOTOR (FM) 6-2
- [15] CONVECTION MOTOR (CM) 6-2
- [16] GRILL HEATING ELEMENT (GH) 6-2
- [17] CONVECTION HEATING ELEMENT (CH) 6-2
- [18] CONVECTION COOKING SYSTEM 6-2
- [19] FIRE SENSING FEATURE 6-2
- [20] OPEN JUDGE BY THERMISTOR 6-2
- [21] DAMPER OPEN-CLOSE MECHANISM 6-2

CHAPTER 7. TROUBLESHOOTING GUIDE

- [1] FOREWORD 7-1
- [2] CHART 7-2

CHAPTER 8. TEST PROCEDURES

- [1] Procedure A: MAGNETRON TEST 8-1
- [2] Procedure B: HIGH VOLTAGE TRANSFORMER TEST 8-2
- [3] Procedure C: HIGH VOLTAGE RECTIFIER TEST 8-2
- [4] Procedure D: HIGH VOLTAGE CAPACITOR TEST 8-2
- [5] Procedure E: SWITCH TEST 8-3
- [6] Procedure F: THERMISTOR TEST 8-3
- [7] Procedure G: THERMAL CUT-OUT TEST 8-3
- [8] Procedure H: MOTOR WINDING TEST 8-3
- [9] Procedure I: NOISE FILTER TEST 8-4
- [10] Procedure J: BLOWN FUSE (F1) 20A 8-4
- [11] Procedure K: BLOWN FUSE (F2) 8A (NOISE FILTER) 8-4
- [12] Procedure L: GRILL HEATING ELEMENTS (TOP) AND CONVECTION HEATING ELEMENT TEST 8-4
- [13] Procedure M: CONTROL PANEL ASSEMBLY TEST 8-4
- [14] Procedure N: JOG AND SWITCH UNIT TEST 8-5
- [15] Procedure O: RELAY TEST 8-6
- [16] Procedure P: PROCEDURES TO BE TAKEN WHEN THE FOIL PATTERN ON THE PRINTED WIRING BOARD (PWB) IS OPEN 8-6

CHAPTER 9. TOUCH CONTROL PANEL ASSEMBLY

- [1] OUTLINE OF TOUCH CONTROL PANEL 9-1
- [2] SERVICING FOR TOUCH CONTROL PANEL 9-1

CHAPTER 10. PRECAUTIONS FOR USING LEAD-FREE SOLDER

CHAPTER 11. COMPONENT REPLACEMENT AND ADJUSTMENT PROCEDURE

- [1] BEFORE OPERATING 11-1
- [2] OUTER CASE REMOVAL 11-1
- [3] HIGH VOLTAGE COMPONENTS REMOVAL 11-1
- [4] HIGH VOLTAGE TRANSFORMER REMOVAL 11-2
- [5] MAGNETRON REMOVAL 11-2
- [6] CONTROL PANEL ASSEMBLY REMOVAL 11-2
- [7] FAN MOTOR REREPLACEMENT 11-2
- [8] TURNTABLE MOTOR REPLACEMENT 11-3
- [9] CONVECTION MOTOR AND CONVECTION HEATING ELEMENT REMOVAL 11-3
- [10] POSITIVE LOCK 11-4
- [11] OVEN LAMP SOCKET REMOVAL 11-4

CHAPTER 1. BEFORE SERVICING

[1] GENERAL IMPORTANT INFORMATION

This Manual has been prepared to provide Sharp Corp. Service engineers with Operation and Service Information.

It is recommended that service engineers carefully study the entire text of this manual, so they will be qualified to render satisfactory customer service.

WARNING: THIS APPLIANCE MUST BE EARTHED

IMPORTANT

THE WIRES IN THIS MAINS LEAD ARE COLOURED IN ACCORDANCE WITH THE FOLLOWING CODE:

GREEN-AND-YELLOW -----EARTH
 BLUE -----NEUTRAL
 BROWN -----LIVE

[2] WARNING

- Note: The parts marked "△" are used at voltage more than 250V. (Parts List)
 Anm: Delar märket med "△" har en spänning överstigande 250V.
 Huom: Huolto-ohjeeseen merkitty "△" osat joissa jännite on yli 250 V.
 Bemerk: Deler som er merket "△" er utsatt for spenninger over 250V til jord.
 Bemærk: Dele mærket med "△" benyttes med højere spænding end 250 volt.

Never operate the oven until the following points are ensured.

- (A) The door is tightly closed.
- (B) The door brackets and hinges are not defective.
- (C) The door packing is not damaged.
- (D) The door is not deformed or warped.
- (E) There is not any other visible damage with the oven.

Servicing and repair work must be carried out only by trained service engineers.

Removal of the outer wrap gives access to potentials above 250V.

All the parts marked "*" on parts list may cause undue microwave exposure, by themselves, or when they are damaged, loosened or removed.

[3] CAUTION MICROWAVE RADIATION

Personnel should not be exposed to the microwave energy which may radiate from the magnetron or other microwave generating devices if it is improperly used or connected. All input and output microwave connections, waveguides, flanges and gaskets must be secured.

Never operate the device without a microwave energy absorbing load attached.

Never look into an open waveguide or antenna while the device is energized.

VARNING MICKROVAGSSTRALING

Personal får inte utsättas för mikrovågsenergi som kan utstråla från magnetronen eller andre mikrovågsalstrande anordningar om dessa är felanslutna eller används på fel sätt. Alla in-och utgångsanslutningar för mikrovågor, vågledare, flänsar och packningar måste vara fast anslutna.

Mikrovågsgeneratoren får inte arbeta utan att absorberande belastning är ansluten. Titta aldrig in i en öppen vågledare eller antenn när mikrovågsgeneratoren är påkopplad eller laddad.

VAROITUS MIKROAALTOSÄTELYÄ

Käyttäjää ei saa joutua alltiiksi mikroaaltoenergialle, jota voi säteillä magnetronista tai muusta mikroaaltoja kehittävästä laitteesta, jos sitä käytetään tai jos se kytketään väärin. Kaikkien mikroaaltoliitännöiden sekä syöttö-että ulostulopuolella, aaltoputkien laippojen ja tiivisteiden tulee olla varmistettuja.

Mikroaaltouunnia ei koskaan saa käyttää ilman kuormaa jossa mikroaaltoenergiaa kuluu. Avoimeen aaltoputkeen tai antenniin ei koskaan saa katsoa virran ollessa kytkettynä.

ADVARSEL MIKROBØLGESTRÅLING

Personell må ikke utsettes for mikrobølge-energi som kan utståles fra magnetronen eller andre mikrobølge-generende deler dersom apparatet feilbetjenes eller blir feiltilkoplet. Alle inn-og ut-tilkoplinger i forbindelse med mikrobølge-strålingen, bølgeledere, flenser og tetningsringer/pakninger må festes ordentlig.

Aldri bruk apparatet med mindre en mikrobølge-absorberende last er plassert i ovnsrommet.

Aldri se direkte inn i en åpen bølgeleder eller antenne imens apparatet er strømførende

ADVARSEL MIKROBØLGEBESTRÅLING

Man bør ikke udsætte sig for mikrobølgebestråling fra magnetronen eller andre mikrobølgefrembringende anordninger, hvilket kan ske hvis apparatet er forkert tilsluttet eller bruges forkert. Alle mikrobølgeindgange og-udgange, bølgeledere, flanger og tætningsstrimler må være forsvarligt udført.

Anvend aldrig ovnen uden en mikrobølgesabsorberende anordning. Se aldrig ind i en åben bølgeleder eller antenne, mens ovnen er i brug.

CHAPTER 2. WARNING TO SERVICE PERSONNEL

(GB) Microwave ovens contain circuitry capable of producing very high voltage and current, contact with following parts will result in electrocution.
High voltage capacitor, High voltage transformer, Magnetron, High voltage rectifier assembly, High voltage harness.

REMEMBER TO CHECK 3D

- 1) Disconnect the supply.
- 2) Door opened, and wedged open.
- 3) Discharge high voltage capacitor.

WARNING: AGAINST THE CHARGE OF THE HIGH-VOLTAGE CAPACITOR

The high-voltage capacitor remains charged about 60 seconds after the oven has been switched off. Wait for 60 seconds and then short-circuit the connection of the high-voltage capacitor (that is, of the connecting-lead of the high-voltage rectifier) against the chassis with the use of an insulated screwdriver.

Sharp recommend that wherever possible fault-finding is carried out with the supply disconnected. It may in some cases, be necessary to connect the supply after the outer case has been removed, in this event carry out 3D checks and then disconnect the leads to the primary of the high voltage transformer. Ensure that these leads remain isolated from other components and the oven chassis. (Use insulation tape if necessary.) When the testing is completed carry out 3D checks and reconnect the leads to the primary of the high voltage transformer.

REMEMBER TO CHECK 4R

- 1) Reconnect all leads removed from components during testing.
- 2) Replace the outer case (cabinet).
- 3) Reconnect the supply.
- 4) Run the oven. Check all functions.

Microwave ovens should not be run empty. To test for the presence of microwave energy within a cavity, place a cup of cold water on the oven turntable, close the door and set the power to HIGH and set the microwave timer for two (2) minutes. When the two minutes has elapsed (timer at zero) carefully check that the water is now hot. If the water remains cold carry out 3D checks and re-examine the connections to the component being tested.

When all service work is completed, and the oven is fully assembled, the microwave power output should be checked and a microwave leakage test should be carried out.

(NL) Magnetronovens bevatten circuits die een zeer hoge spanning en stroom kunnen voortbrengen. Contact met de volgende onderdelen kan elektrocutie tot gevolg hebben.
Hoogspanningscondensator, hoogspanningstransformator, magnetron, hoogspanningsgelijkrichter, hoogspanningskabelboom.

VERGEET DE VOLGENDE 3 STAPPEN NIET

- 1) Haal de stekker uit het stopcontact.
- 2) Open de deur en zorg ervoor dat hij niet dicht kan vallen.
- 3) Ontlaad de hoogspanningscondensator.

PAS OP VOOR DE ELECTRISCHE LADING VAN DE HOOGSPANNINGSCONDENSATOR

De hoogspanningscondensator blijft nog ongeveer 60 seconden lang opgeladen, nadat de oven is uitgeschakeld. Wacht 60 seconden voordat u de verbinding van de hoogspannings-condensator (m.a.w. de verbindingsdraad van de hoogspanningsgelijkrichter) met een geïsoleerde schroevendraaier kortsluit tegen het chassis.

Sharp beveelt ten sterkste aan dat, voor zover mogelijk, defecten worden opgespoord wanneer de stekker uit het stopcontact is gehaald. Soms is het nodig om de stroomtoevoer weer tot stand te brengen nadat de buitenmantel verwijderd is. Herhaal dan de bovengenoemde 3 stappen en haal de elektrische draden uit de primaire zijde van de vermogenstransformator. Zorg ervoor dat deze draden geïsoleerd blijven van andere elementen en van het chassis van de oven. (Gebruik zo nodig isolatieband.) Wanneer de test is uitgevoerd, herhaalt u de bovenstaande 3 stappen en verbindt u de elektrische draden weer aan de primaire zijde van de vermogenstransformator.

VERGEET DE VOLGENDE 4 STAPPEN NIET

- 1) Sluit de draden weer aan die zijn losgehaald voor de test.
- 2) Plaats de buitenmantel weer om het toestel heen (kabinet).
- 3) Stop de stekker weer in het stopcontact.
- 4) Zet de oven aan. Controleer alle functies.

Magnetronovens mogen niet leeg aangezet worden. Om te controleren of er microgolff-energie binnen de oven wordt geproduceerd, plaatst u een mok met koud water op de draaitafel van de oven, sluit de deur, zet de oven op HIGH en stelt de klok van de magnetron in op twee (2) minuten. Wanneer de twee minuten voorbij zijn (klok staat op nul), controleert u voorzichtig of het water heet is. Indien het water nog steeds koud is, herhaalt u de allereerste drie stappen en controleer nogmaals de aansluitingen naar de geteste onderdelen.

Wanneer alle reparaties zijn uitgevoerd en de oven weer in elkaar is gezet, moet de het magnetronvermogen worden gecontroleerd en moet worden gecontroleerd of er geen microgolfflekage is.

- (E) Los hornos de microondas contienen circuitos eléctricos capaces de producir voltajes de alta tensión y descargas eléctricas. Para evitar el riesgo de electrocución, absténgase de tocar los siguientes componentes: condensador de alta tensión, transformador de alta tensión, magnetron, dispositivo del rectificador de alta tensión y arnés de alta tensión.

RECUERDE LA COMPROBACION 3D

- 1) Desconecte la alimentación.
- 2) Deje la puerta abierta y calzada.
- 3) Descargue el condensador de alto voltaje.

ADVERTENCIA SOBRE LA CARGA DEL CONDENSADOR DE ALTOVOLTAJE

El condensador de alto voltaje permanece cargado unos 60 segundos después de haber apagado el horno. Espere 60 segundos y luego ponga en cortocircuito la conexión del condensador de alto voltaje (esto es, del conductor de conexión del rectificador de alto voltaje) al chasis con un destornillador de mango aislado.

Se recomienda encarecidamente que siempre que sea posible la localización de fallos se realice con la alimentación desconectada. Puede ser que en algunos casos sea necesario conectar la alimentación después de haber retirado la carcasa exterior. En este caso, realice las comprobaciones 3D y luego desconecte los conductores del primario del transformador de alimentación. Asegúrese de que estos conductores permanezcan aislados de otros componentes y del chasis del horno. (Use cinta aislante si es necesario). Cuando termine la prueba efectúe las comprobaciones 3D y reconecte los conductores al primario del transformador de alimentación.

RECUERDE LA COMPROBACION 4C

- 1) Conecte todos los componentes desconectados de los componentes durante la prueba.
- 2) Coloque la carcasa exterior (cabina).
- 3) Conecte la alimentación.
- 4) Compruebe todas sus funciones después de poner en marcha el horno.

Los hornos de microondas no deben funcionar vacíos. Para comprobar la presencia de energía de microondas dentro de una cavidad, coloque una taza de agua fría en el plato giratorio del horno, cierre la puerta y ponga la potencia en HIGH (alta) y coloque el temporizador en dos (2) minutos. Cuando transcurran los dos minutos (temporizador a cero) compruebe cuidadosamente que el agua se ha calentado. Si el agua permaneciese fría, efectúe las comprobaciones 3D y vuelva a examinar las conexiones de los componentes que han sido probados.

Cuando haya terminado la intervención en el equipo y el horno haya sido ensamblado de nuevo completamente, deberá comprobar la potencia de salida de microondas y realizar una prueba de fugas de microondas.

- (SV) Mikrovågsugnar innehåller kretsar som producerar mycket höga spänningar och strömmar. Kontakt med följande komponenter kan leda till dödsfall: Högsämningskondensator, transformator, magnetron, högsämnings likriktare, högsämnings kablage.

KOM IHÅG ATT KONTROLLERA 3 STEG

- 1) Koppla från strömkällan.
- 2) Öppna dörren på glänt.
- 3) Ladda ur högsämningskondensatorn.

VARNING FÖR LADDNINGEN I HÖGSÄMNINGSKONDENSATORN

Högsämningskondensatorn är laddad i 60 sekunder efter det att ugnen stängts av. Vänta 60 sekunder och korigslut sedan kondensatorns anslutning (dvs anslutningen till högsämningslikriktaren) till chassiet med hjälp av en isolerad skruvmejsel.

Sharp rekommenderar att felsökning sker med strömmen fränkopplad. Ibland kan det var nödvändigt att koppla på strömmen efter det att höljet avlägsnats, utför da 3 Steg kontrollen och koppla sedan från ledarna till transformatorns primärsida. Se till att ledarna är isolerade från andra komponenter och chassiet. (Använd isoleringsband om detbehövs). När Du testat färdigt utför Du 3 Steg kontrollen ochansluter ledningarna till transformatorns primärsida igen.

KOM IHÅG ATT KONTROLLERA 4 STEG

- 1) Anslut alla ledningar som använts vid testning
- 2) Sätt tillbaka ytterhöljet.
- 3) Anslut strömkällan på nytt.
- 4) Sätt på ugnen. Kontrollera alla funktioner.

Mikrovågsugnar får inte användas tomma. Kontrollera mikrovågsstrålningen i olika delar av ugnen genom att placera en kopp med kallt vatten på ugnens tallrik, stäng dörren, ställ in HIGH och ställ in 2 minuter på timern. När två minuter har gått (timern visar 0) kontrollerar du om vattnet är varmt. Om vattnet fortfarande är kallt utför Du 3 steg kontroller och kontrollerar anslutningarna till varje enskild komponent på nytt.

När all service är klar och ugnen ihopskruvad skall ugnens uteffekt och eventuellt mikrovågsläckage kontrolleras.

I I forni a microonde contengono un circuito elettrico in grado di generare tensioni e correnti estremamente elevate. L'eventuale contatto con i seguenti componenti può causare la folgorazione: condensatore ad alta tensione; trasformatore ad alta tensione; magnetron; rettificatore alta tensione; cablaggio ad alta tensione.

TRE OPERAZIONI IMPORTANTI PER INCOMINCIARE

- 1) Scollegare l'alimentazione elettrica.
- 2) Verificare che la porta sia bloccata in posizione aperta.
- 3) Scaricare il condensatore ad alta tensione.

ATTENZIONE AL CONDENSATORE AD ALTA TENSIONE: PUÒ ESSERE CARICO

Il condensatore ad alta tensione rimane carico per circa 60 secondi dopo lo spegnimento del forno. Occorre quindi aspettare 60 secondi prima di cortocircuitare, utilizzando un cacciavite con impugnatura isolata, il collegamento del condensatore ad alta tensione (cioè del conduttore di collegamento del raddrizzatore ad alta tensione) sul telaio del forno.

Sharp raccomanda, nei limiti del possibile, che la ricerca dei guasti avvenga in assenza di alimentazione elettrica. In alcuni casi tuttavia, può essere necessario alimentare l'apparecchio dopo aver rimosso la scatola esterna. In questo caso eseguire i tre controlli sopra citati e quindi scollegare i connettori dal primario del trasformatore. Assicurarsi che tali connettori non vengano a contatto con altri componenti, né con il telaio del forno (fare uso, se necessario, di nastro isolante). Al termine dell'intervento, eseguire nuovamente i tre controlli e ricollegare i conduttori al primario del trasformatore.

QUATTRO VERIFICHE IMPORTANTI DA NON DIMENTICARE

- 1) Ricollegare tutti i conduttori staccati dai vari componenti durante l'intervento.
- 2) Rimontare la scatola esterna.
- 3) Ripristinare l'alimentazione elettrica.
- 4) Rimettere in funzione il forno. Controllare tutte le funzioni.

I forni a microonde non devono mai funzionare a vuoto. Per verificare la presenza di energia da microonde all'interno di una cavità, mettere una tazza di acqua fredda sul piatto rotante del forno, chiudere la porta, regolare la potenza su HIGH ed impostare il temporizzatore su due (2) minuti. Trascorsi i due minuti (temporizzatore a zero), controllare accuratamente che ora l'acqua sia calda. Se l'acqua è rimasta fredda, eseguire i tre controlli iniziali e verificare nuovamente i collegamenti del componente in questione.

Dopo aver portato a termine le operazioni di manutenzione e rimontato il forno, è necessario controllare la potenza delle microonde emesse ed eseguire un test per verificare che non vi sia alcuna dispersione.

CHAPTER 3. PRODUCT SPECIFICATIONS

TEM	DESCRIPTION
Power Requirements	230 Volts 50 Hertz Single phase, 3 wire earthed
Power Consumption	Microwave cooking 1.5 kW Approx 6.7A Convection cooking 2.8 kW Approx 12.2A
	Grill cooking 2.8 kW Approx 12.2A
	Dual cooking Micro and Grill -----2.80kW Approx 12.4A Micro and Convection ---- 2.95kW Approx. 13.0A
Power Output	900 watts nominal of RF microwave energy (IEC60705 Test Procedure) Operating frequency 2450 MHz
Grill heating element Power Output	1300W (650W x 2)
Convection heating element Power Output	1450W
Outer Case Dimensions	Width 550 mm Height 368 mm including foot Depth 537 mm NOTE: The Depth does not include the door opening handle.
Cooking Cavity Dimensions	Width 375 mm NOTE: Internal capacity is calculated by measuring maximum width, depth and height. Height 272 mm Actual capacity for holding food is less. Depth 395 mm
Turntable diameter	362 mm
Control Complement	Touch Control System Timer (0 - 90 minutes) Clock (1:00 - 12:59) or (0:00 - 23:59) Microwave Power for Variable Cooking Repetition Rate; 900W Full power throughout the cooking time 630W approx. 70% of FULL Power 450W approx. 50% of FULL Power 270Wapprox. 30% of FULL Power 90Wapprox. 10% of FULL Power Convection temperature control range: 250°C, 230°C, 220°C, 200°C, 190°C, 180°C, 160°C, 130°C, 100°C and 40°C LESS(▼)/ MORE(▲) buttons LANGUAGE button INFORMATION button EXPRESS COOK button EXPRESS DEFROST button AUTO REHEAT button AUTO COOK button COOKING MODE dial CONVECTION button MICROWAVE POWER LEVEL button TIMER/WEIGHT dial CLOCK setting button STOP button, ⏪ (START)/+ 1min button
Net Weight	Approx. 23 kg

CHAPTER 4. APPEARANCE VIEW

[1] OVEN

1. Grill heating element
2. Oven lamp
3. Control panel
4. Shelf runners
5. Waveguide cover
6. Oven cavity
7. Coupling
8. Door seals and sealing surfaces
9. Door opening handle
10. Air-vent openings
11. Outer cabinet
12. Power cord
13. Turntable
14. Turntable support
15. High Rack
16. Low Rack
17. Baking tin
18. Square shelf (R-939(BK) only)
19. Square fin (R-939(BK) only)

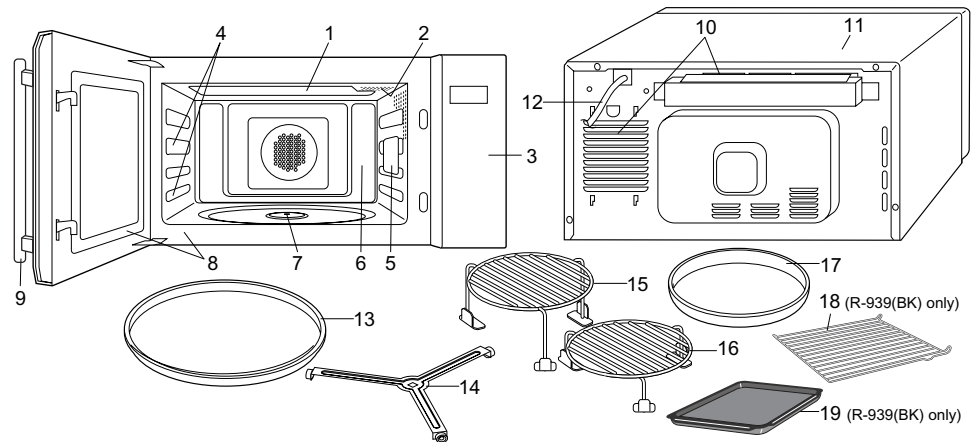

[2] TOUCH CONTROL PANEL

Digital display and indicators:

1. COOKING IN PROCESS indicator
2. GRIL indicator
3. CONVECTION indicator
4. MICROWAVE indicator
5. INFO indicator

Operating buttons:

6. INFORMATION button
7. LANGUAGE button
8. EXPRESS DEFROST button
9. AUTO REHEAT button
10. COOKING MODE dial: Rotate the dial so that indicator points to appropriate symbol.

 for microwave cooking

 for microwave cooking with GRILL

 for microwave cooking with CONVECTION

 for GRILL

 for CONVECTION

11. CONVECTION button

Press to change the convection temperature.

12. TIMER/WEIGHT knob

Rotate the knob to enter either the cooking/defrosting time or weight food.

13.  (START) / 1 min button (See note)

NOTE: This features is disabled after three minutes when the oven is not in use. This feature is automatically enabled when the door is opened and closed or the STOP button is pressed.

14. STOP button

15. CLOCK SETTING button

16. MICROWAVE POWER LEVEL button: Press to change the microwave power setting.

17. AUTO COOK button

18. EXPRESS COOK button
19. LESS / MORE buttons

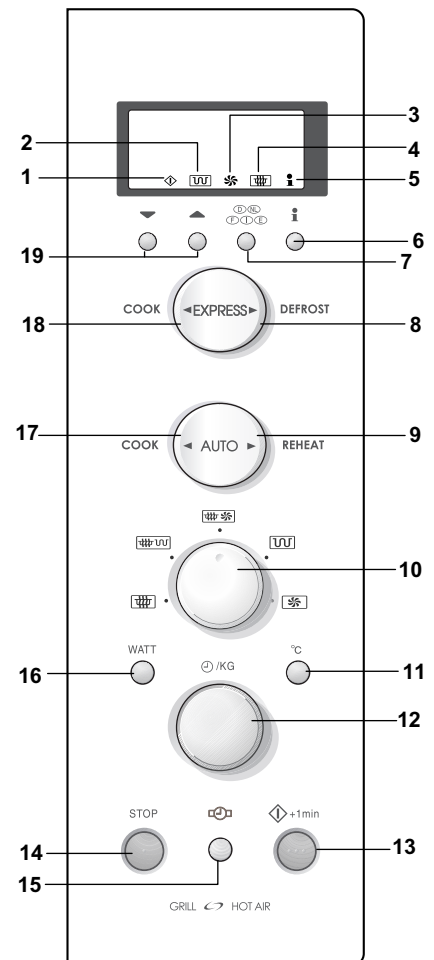

CHAPTER 5. OPERATION SEQUENCE

[1] OFF CONDITION

Closing the door activates the monitored latch switch and the stop switch.

IMPORTANT

When the oven door is closed, the contacts COM-NC of the monitored switch must be open. When the microwave oven is plugged in a wall outlet (230V / 50Hz), the line voltage is supplied to the noise filter.

Figure O-1 on page 14-1

1. The control unit is not energized. The display shows nothing (Fig. O-1 (a)).
2. Open the door. The contacts (COM-NC) of the monitored latch switch are closed and the control unit is energized. Then contacts of relays RY1 and RY5 are closed, and the oven lamp will light and the display will show "SELECT LANGUAGE" in 5 languages. (Fig. O-1(b)).

NOTE: NOTE: Once the language is selected using the LANGUAGE key, the display will show "ENERGY SAVE MODE TO GO OUT OF ENERGY SAVE MODE SET CLOCK" when the oven is plugged in.

3. Close the door. The contacts (COM-NC) of the monitored latch switch are opened and the contacts of relay RY1 are opened and the oven lamp will be turned off. The display will show ". 0". (Fig. O-1(c)).

NOTE: Energy save mode

- 1) If the oven has not been used for more than 3 minutes, the contacts of the relay RY5 will be opened and the control unit will be not energized. Open and close the door, the control unit will resume.
- 2) If the clock is set, this energy save mode does not work.
- 3) If the display shows different messages from ENERGY SAVE MODE, the oven may be set in demo mode. Close the door, see operation manual to cancel demo mode.

[2] MICROWAVE COOKING CONDITION

1. HIGH COOKING

Rotate the COOKING MODE dial to the micro setting. And press the POWER LEVEL button once. And enter the cooking time by rotating the TIMER/WEIGHT dial. And start the oven by pressing START button.

Function sequence

Figure O-2 on page 14-2

CONNECTED COMPONENTS	RELAY
Oven lamp, Turntable motor	RY1
High voltage transformer	RY2
Fan motor,	RY6

1. The line voltage is supplied to the primary winding of the high voltage transformer. The voltage is converted to about 3.3 volts A.C. output on the filament winding and high voltage of approximately 2000 volts A.C. on the secondary winding.
2. The filament winding voltage (3.3 volts) heats the magnetron filament and the high voltage (2000 volts) is sent to the voltage doubling circuit, where it is doubled to negative voltage of approximately 4000 volts D.C..

3. The 2450 MHz microwave energy produced in the magnetron generates a wavelength of 12.24 cm. This energy is channelled through the waveguide (transport channel) into the oven cavity, where the food is placed to be cooked.

4. When the cooking time is up, a signal tone is heard and the relays RY1 + RY2 + RY6 go back to their home position.

The circuits to the oven lamp, high voltage transformer, fan motor and turntable motor are cut off.

5. When the oven door is opened during a cooking cycle, the switches come to the following condition.

SWITCH	CONTACT	CONDITION	
		DURING COOKING	DOOR OPEN (NO COOKING)
Monitored latch switch	COM-NO	Closed	Opened
	COM-NC	Opened	Closed
Stop switch	COM-NO	Closed	Opened
Monitor switch	COM-NO	Closed	Opened
	COM-NC	Opened	Closed

The circuit to the high voltage transformer is cut off when the contacts of relay RY2, and the contacts (COM-NO) of the monitored latch switch SW1 and monitor switch SW3 are made open. The circuit to the fan motor is cut off when the relay RY6 is made open. The circuit to the turntable motor is cut off when the contacts (COM-NO) of the monitored latch switch SW1 are made open. The oven lamp remains on even if the oven door is opened after the cooking cycle has been interrupted, because the relay RY1 stays closed. Shown in the display is remaining time.

6. MONITOR SWITCH CIRCUIT

The monitor switch SW3 is mechanically controlled by the oven door, and monitors the operation of the monitored latch switch SW1.

- 1) When the oven door is opened during or after the cycle of a cooking program, the monitored latch switch SW1 and stop switch SW2 must open their contacts (COM-NO) first. And the contacts (COM-NC) of the monitored latch switch SW1 are made closed. After that the contacts (COM-NC) of the monitor switch SW3 can be closed and the contacts (COM-NO) of monitor switch SW3 are made open.
- 2) When the oven door is closed, the contacts (COM-NC) of the monitor switch SW3 must be opened and the contacts (COM-NO) of monitor switch SW3 must be closed. After that the contacts (COM-NO) of the monitored latch switch SW1 and the stop switch SW2 are made closed. And the contacts (COM-NC) of the monitored latch switch SW1 are made open.
- 3) When the oven door is opened and the contacts (COM-NO) of the monitored latch switch SW1 remain closed, the fuse F2 F8A will blow. Because the relay RY1 and monitor switch SW3 are closed and a short circuit is caused.

2. MEDIUM HIGH, MEDIUM, MEDIUM LOW, LOW COOKING

When the microwave oven is preset for variable cooking power, the line voltage is supplied to the high voltage transformer intermittently within a 32-second time base through the relay contact which is coupled with the current-limiting relay RY2. The following levels of microwave power are given.

SETTING;

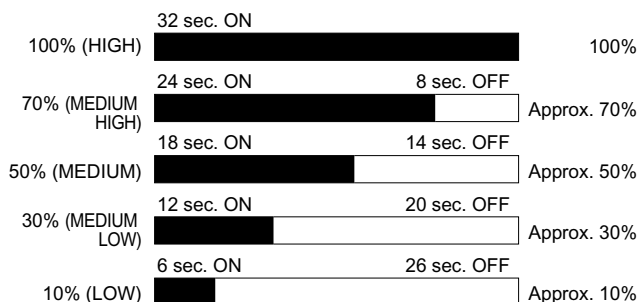

NOTE: The ON/OFF time ratio does not exactly correspond to the percentage of microwave power, because approx. 3 seconds are needed for heating up the magnetron filament.

[3] GRILL COOKING CONDITION

1. TOP GRILL (Figure O-3)

In this condition the food is cooked by the top grill heating element . Rotate the COOKING MODE dial to  GRILL setting. And enter the desired cooking time by rotating the TIMER/WEIGHT dial. When the START button is pressed, the following operations occur:

1. The numbers on the digital readout start the count down to zero.
2. The oven lamp, cooling fan motor and turntable motor are energized.
3. The relay RY3 is energized and the main supply voltage is applied to the top grill heating elements.
4. Now, the food is cooked by the top grill heating elements.

NOTE: The convection cooking condition will be carried out simultaneously until the temperature of the oven cavity rise to 220°C.

[4] CONVECTION COOKING CONDITION

1. PRE-HEATING (by 40°C - 130°C)

Rotate the COOKING MODE dial to the  convection setting. And programme the desired convection temperature of 40°C - 130°C by touching CONVECTION button. When the START button is touched, the following operations occur:

1. The relays RY1, RY6 and RY7 are energized, the oven lamp, turntable motor, fan motor and convection motor are turned on.
2. The relay RY4 is energized and the main supply voltage is applied to the convection heating element.
3. After the temperature of oven cavity rises to the selected one, the oven will continue to turned the convection heating element on and off to maintain the temperature for 30 minutes.:

2. PRE-HEATING (by 160°C - 250°C)

Rotate the COOKING MODE dial to the  convection setting. And programme the desired convection temperature of 160°C - 250°C by touching CONVECTION button. When the START button is touched, the following operations occur:

1. The relays RY1, RY6 and RY7 are energized, the oven lamp, turntable motor, fan motor and convection motor are turned on.
2. The relay RY4 and RY3 are is energized and the main supply voltage is applied to the convection heating element and the grill heating elements.
3. After the temperature of oven cavity rises to the selected one, the oven will continue to turned the convection heating element on and off to maintain the temperature for 30 minutes. And simultaneously the grill heating element will be operated at 10% power output.

3. CONVECTION COOKING (by 250°C)

Rotate the COOKING MODE dial to the  convection setting. And enter the cooking time by rotating the TIMER/ WEIGHT dial. And select the desired cooking temperature 250°C by pressing the CONVECTION button. When the START button is pressed, the following operations occur:

1. The relays RY1, RY6 and RY7 are energized, the oven lamp, turntable motor, fan motor and convection motor are turned on.
2. The relay RY4 and RY3 are energized and the main supply voltage is applied to the convection heating element and the grill heating elements.
3. The oven will continue to turn the convection heating element on and off to maintain the temperature for the programmed cooking time. And simultaneously the grill heating elements will be operated at 10% power output.

4. CONVECTION COOKING (by 40°C - 230°C)

Rotate the COOKING MODE dial to the  convection setting. And enter the cooking time by rotating the TIMER/ WEIGHT dial. And select the desired cooking temperature 40°C - 230°C by pressing the CONVECTION button. When the START button is pressed, the following operations occur:

1. The relays RY1, RY6 and RY7 are energized, the oven lamp, turntable motor, fan motor and convection motor are turned on.
2. The relay RY4 is energized and the main supply voltage is applied to the convection heating element.
3. The oven will continue to turn the convection heating element on and off to maintain the temperature for the programmed cooking time.

[5] DUAL COOKING CONDITION

1. MICROWAVE AND CONVECTION (Figure O-5a)

Rotate the COOKING MODE dial to  DUAL 1 setting. And enter the desired cooking time by rotating the TIMER/WEIGHT dial. And press POWER LEVEL button to set the desired microwave power. And press the CONVECTION button to set the cooking temperature. When the START button is pressed, the following operations occur:

NOTE: The 100% microwave power level can not be selected.

When the START button is touched, the following operations occur:

1. The numbers on the digital read-out start the count down to zero.
2. The oven lamp, fan motor, turntable motor and convection motor are energized.
3. The relay RY4 will be energized and the main supply voltage is applied to the convection heating element.
4. The relay RY2 is energized and the microwave energy is generated by magnetron.
5. Now, the food is cooked by microwave and convection energy simultaneously.

2. MICROWAVE AND TOP GRILL (Figure O-5b)

Rotate the COOKING MODE dial to  DUAL 2 setting. And enter the desired cooking time by rotating the TIMER/ WEIGHT dial. And press POWER LEVEL button to set the desired microwave power. When the START button is pressed, the following operations occur:

1. The numbers on the digital read-out start the count down to zero.
2. The oven lamp, fan motor and turntable motor are energized.
3. The relay RY3 is energized and the main supply voltage is applied to the grill heating elements.
4. The relay RY2 is energized and the microwave energy is generated by magnetron.
5. Now, the food is cooked by microwave and grill simultaneously.

[6] ON/OFF TIME RATIO

In dual cooking, the magnetron operate within a 48 second time base. The following table is the ON / OFF time ratio at each power output of the magnetron.

POWER OUTPUT	ON TIME	OFF TIME
100%	48 sec.	0 sec.
70%	36 sec.	12 sec.
50%	26 sec.	22 sec.
30%	16 sec.	32 sec.
10%	8 sec.	40 sec.

[7] AUTOMATIC COOKING

Auto Cook functions automatically work out the correct cooking mode and cooking time and/or cooking temperature. They will cook according to the special cooking sequence.

[8] POWER OUTPUT REDUCTION

After the same cooking mode is carried out for more than the basis cooking time, the power output is automatically reduced by turning the control relays on and off intermittently, as shown in the table below. This is to protect the oven door against temperature rising.

Cooking mode		Basis cooking time (minutes)	Reduced power output (%)	Time base (seconds)
Microwave (100%)		20	70	32
Grill		15	70	48
Convection		No reduction		
D	Micro. (70%)	40 (Micro.)	50	48
	+ Grill	15 (Grill)	50	48
U	Micro. (100%)	15 (Micro.)	50	48
	+ Grill	15 (Grill)	50	48
L	Micro. (70%)	40 (Micro.)	50	48
	+ Conv.	No reduction		

- NOTE: 1) If the multiple sequence cooking is carried out in the same mode, the basis cooking time is calculated from the first.
- 2) Even if the cooking is stopped by the STOP key or opening the door, the basis cooking time is calculated from the first.
- 3) If the same cooking mode is repeated within 1 minute and 15 seconds, the basis cooking time is calculated from the first.
- 4) If the same menu of Automatic Cooking is repeated within 1 minute and 15 seconds, the power output of the microwave or the grill will be reduced to 70% after 20 minutes when the oven is started at first.

[9] FAN MOTOR OPERATION

(in Grill, Convection and Dual mode)

When oven is stopped during cooking, or after the cooking is completed, the fan motor will operate if the oven cavity temperature is above 120°C, and the fan motor will stop if the oven cavity temperature is below 105°C.

[10] CONVECTION MOTOR OPERATION

If the temperature of oven cavity is higher than 120°C after and when operated by 250°C convection cooking, 250°C dual convection cooking or 250°C preheating, the convection motor will operate for maximum 1 minute until the oven cavity temperature drops below 105°C.

ON/OFF TIME RATIO

In grill cooking, convection cooking or dual cooking, the top heater, bottom heater or magnetron operate within a 48 second time base. The following table is the ON / OFF time ratio at each power output of the top heaters, bottom heater or magnetron.

CHAPTER 6. FUNCTION OF IMPORTANT COMPONENTS

[1] DOOR OPEN MECHANISM

The door can be opened by pulling the door handle.

When the door handle is pulled, the latch head is moved upward, and released from the latch hook now the door can be opened.

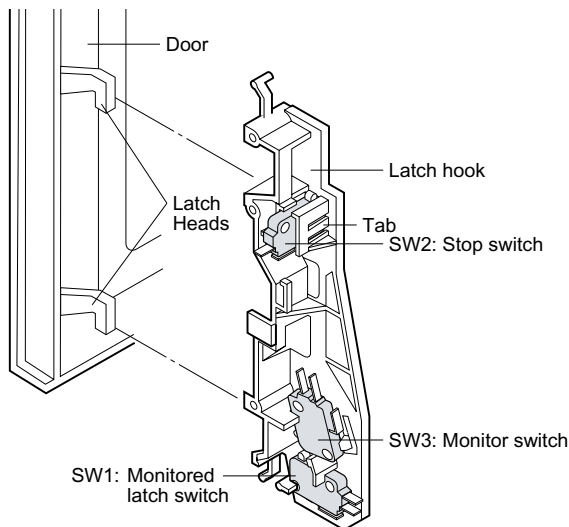

Figure D-1. Door Open Mechanism

[2] MONITORED LATCH SWITCH (SW1)

1. When the oven door is closed, the contacts (COM-NO) of the switch must be closed. And the contacts (COM-NC) must be opened.
2. When the oven door is opened, the contacts (COM-NO) of the switch must be opened. And the contacts (COM-NC) must be closed.

[3] STOP SWITCH (SW2)

1. When the oven door is closed, the contacts (COM-NO) of the switch must be closed.
2. When the oven door is opened, the contacts (COM-NO) of switch must be opened.

[4] MONITOR SWITCH (SW3)

The monitor switch is activated (the contacts opened) by the upper latch head on the door while the door is closed. The switch is intended to render the oven inoperative by means of blowing the fuse F2 F8A when the contacts of the monitored latch switch SW1 fail to open when the door is opened.

Function

1. When the door is opened, the contacts (COM-NC) of monitor switch SW3 close (to the ON condition) due to their being normally closed and contacts (COM-NO) open. At this time the contacts (COM-NO) of monitored latch switch SW1 is in the OFF condition (contacts open) due to their being normally open contact switches.
2. As the door goes to a closed position, the monitor switch SW3 contacts (COM-NC) are opened and contacts (COM-NO) closed and then contacts (COM-NO) of monitored latch switch SW1 and stop switch SW2 are closed. (On opening the door, each of these switches operate inversely.)
3. If the door is opened and the monitored latch switch SW1 contacts (COM-NO) fail to open, the fuse F2 F8A blows immediately after closing of the monitor switch SW3 (COM-NC) contacts.

CAUTION: BEFORE REPLACING A NOISE FILTER (BLOWN FUSE F2 F8A), TEST THE MONITORED LATCH SWITCH SW1 AND MONITOR SWITCH SW3 FOR PROPER OPERATION. (REFER TO CHAPTER "TEST PROCEDURE").

[5] FUSE (F1) 20A 250V

If the wire harness or electrical components are shortcircuited, this fuse F1 20A blows to prevent an electric shock or fire hazard.

[6] FUSE (F2) F8A 250V (NOISE FILTER)

1. If the wire harness or electrical components are shortcircuited, this fuse blows to prevent an electric shock or fire hazard.
2. The fuse also blows when the monitored latch switch SW1 remains closed with the oven door open and when the monitor switch SW3 contact (COM-NC) closes.
3. The fuse also blows when the asymmetric rectifier, H.V. rectifier, H.V. wire harness, H.V. capacitor, magnetron or secondary winding of high voltage transformer is shorted.

[7] TC TRANSFORMER

T/C transformer converts A.C. line voltage into low voltage to drive the control unit.

[8] THERMAL CUT-OUT (TC1) 125C (MG)

This thermal cut-out protects the magnetron against overheat. If the temperature goes up higher than 125°C because the fan motor is interrupted or the ventilation openings are blocked, the thermal cut-out TC1 will open and switch off all the electrical parts. The defective thermal cut-out must be replaced with a new one.

[9] THERMAL CUT-OUT (TC2) 170C (GRILL)

This thermal cut-out protects the oven against the overheat during grill cooking, convection cooking or dual cooking. If the temperature rises above 170°C because the fan motor is interrupted, the air inlet duct is blocked or the ventilation openings are obstructed, the thermal cut-out TC2 opens and switches off all the electrical parts. When the cut-out cools itself down to the operating temperature of 155°C, the contacts of the thermal cut-out will close again.

[10] THERMAL CUT-OUT (TC3) 170C (CONV.)

This thermal cut-out protects the convection motor against overheating. If the temperature of the thermal cut-out TC3 rises above 170°C because the convection fan is interrupted, the ventilation openings are obstructed or the other abnormal matter occurs, the thermal cut-out opens and switches off the convection heating element and the other electrical parts. When the cut-out cools itself down to the operating temperature of 155°C, the contacts of the thermal cut-out will close again.

[11] ASYMMETRIC RECTIFIER

The asymmetric rectifier is solid state device that prevents current flow in both directions. And it prevents the temperature rise of the high voltage transformer by blowing the fuse F2 F8A when the high voltage rectifier is shorted.

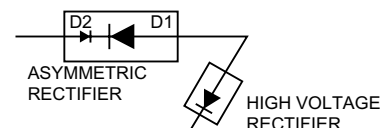

R939(W)

the asymmetric rectifier is 1.7 KV. D1 and D2 of the asymmetric rectifier or high voltage rectifier are shorted when the each peak reverse voltage goes beyond the each rated peak reverse voltage. (The process of the blowing the fuse F2 F8A.)

1. The high voltage rectifier is shorted by some fault when microwave cooking or dual cooking.
2. The peak reverse voltage of D2 of the rectifier goes beyond the rated peak reverse voltage 1.7 KV in the voltage doubler circuit.
3. D2 of the rectifier is shorted.
4. The large electric currents flow through the high voltage winding of the high voltage transformer.
5. The large electric currents beyond 8A flow through the primary winding of the high voltage transformer.
6. The fuse F2 F8A blows by the large electric currents.
7. The power supplying to the high voltage transformer is cut off.

[12] NOISE FILTER

The noise filter assembly prevents radio frequency interference that might flow back in the power circuit.

[13] TURNTABLE MOTOR (TTM)

The turntable motor rotates the turntable.

[14] FAN MOTOR (FM)

The fan motor drives a blade which draws external cool air. This cool air is directed through the air vanes surrounding the magnetron and cools the magnetron. This air is channelled through the oven cavity to remove steam and vapours given off from heating food. It is then exhausted through the exhausting air vents of the oven cavity.

[15] CONVECTION MOTOR (CM)

The convection motor drives the convection fan and provide the heated air.

[16] GRILL HEATING ELEMENT (GH)

The grill heating elements are provided to brown the food and are located on the top of the oven cavity.

[17] CONVECTION HEATING ELEMENT (CH)

The convection heating element situated at the rear of the oven cavity. It is intended to heat air driven by the convection fan. The heated air is kept in the oven and force-circulated and reheated by the convection heating element.

[18] CONVECTION COOKING SYSTEM

This oven is designed with a hot air heating system where food is heated by forced circulation of the hot air produced by the grill heaters. The air heated by the grill heating elements is circulated through the convection passage provided on the outer casing of the oven cavity by means of the convection fan which is driven by the convection motor. It is then enters the inside of the oven through the vent holes provided on the back side of the oven. Next, the hot air heats the food on the turntable and leaves the oven cavity through the vent in the oven cavity rear wall. In this way, the hot air circulates inside the oven cavity to raise its temperature and, at the same time, comes into contact with the food being cooked. When the temperature inside the oven cavity reaches the selected temperature, the heating elements are de-energized. When the temperature inside the oven cavity drops below the selected temperature, the heating elements are energized again. In this way, the inside of the oven cavity is maintained at approximately the selected temperature.

When the convection time reaches "0", the heating elements are de-energized and the convection fan stops operating and the oven shuts off. At that time if the cavity air temperature has risen above 120°C, the fan motor remains rotating. Automatically the fan motor will be shut down at low temperature (less than 105°C).

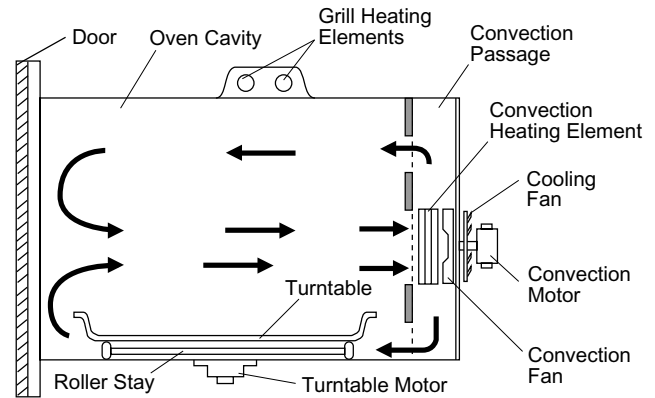
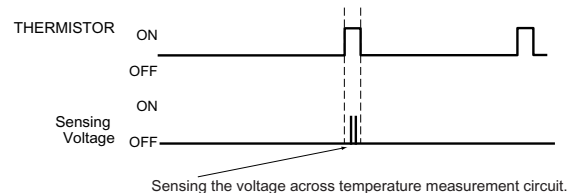

Figure D-2. Convection Cooking System

[19] FIRE SENSING FEATURE

The oven will stop its operation when there is a fire in the oven cavity in microwave cooking condition. LSI measures the voltage across the temperature measurement circuit intermittently within 32-seconds time base since the oven is started in microwave cooking condition. The oven will stop its operation when the difference of the voltage is more than 0.39 volts in microwave cooking condition.

1. Within a 32-seconds base, the thermistor is energized for 2 seconds. At that time, the voltage across the temperature measurement circuit is measured.
2. The oven carries out the procedure above again. If the second voltage is 0.39V higher than first voltage, LSI judges it is a fire in the oven cavity and stop the oven.
3. When LSI judges it is a fire in the oven cavity, LSI will switch off the relays to high voltage transformer and fan motor and LSI stops counting down.



Sensing the voltage across temperature measurement circuit.

[20] OPEN JUDGE BY THERMISTOR

1. If the temperature of the thermistor does not rise to more than 40°C after 4 minutes and 15 seconds from when the oven is started in convection, grill or dual cooking mode, the oven is turned off.
2. When the thermistor or the wire harness to the thermistor is opened, the oven is turned off after 4 minutes and 15 seconds because this condition is same as above.

[21] DAMPER OPEN-CLOSE MECHANISM

Damper position is set automatically by damper motor DM, damper switch and motor cam. These components are operated by a signal that judges if microwave cooking or convection cooking operation is selected by the CPU unit.

1. Microwave Cooking:

Damper is in the open position, because a portion of cooling air is channelled through the cavity to remove steam and vapours given off from the heating foods. It is then exhausted at the top of the oven cavity into a condensation compartment.

2. Convection Cooking:

Damper is in the closed position, so that no hot air will be allowed to leak out the oven cavity.

3. Damper Operation

1. When power supply cord is plugged in or when the control unit resumes after energy save mode finishes:
 - 1) When power supply cord is plugged in, a signal is sensed in the control unit, and operates shut-off relay (RY8).
 - 2) Contacts of shut-off relay (RY8) close, the damper motor DM is energized, opening the damper door.
 - 3) When the damper is moved to the open position by the damper cam, damper switch SW4 is closed (ON position).
 - 4) The signal of damper switch SW4 is re-sensed in the control unit and shut-off relay (RY8) is turned off.
 - 5) The rated voltage to the damper motor DM is stopped and the motor turns off.
2. When oven is microwave cooking: Damper is in the open position
3. When oven is convection cooking:
 - 1) Damper motor DM is energized right after the oven is started.
 - 2) When damper is in the closed position (damper switch SW4 is OFF), its signal is sensed by the control unit, and shut-off relay (RY8) is de-energized.
 - 3) The damper is held in the closed position during the convection cooking operation.
 - 4) At the end of the convection cooking, when the fan motor FM stops, shut-off relay (RY8) is energized, and the damper is returned to the open position.

NOTE: If the damper door is not in the proper position, closed during convection, grill or dual, or open during microwave, the control unit will stop oven operation after 1 minute.

4. Operation of damper is shown below.

Cooking Mode	Operation of Damper
Microwave cooking	Open
Convection cooking	Closed
Grill; during backed up with convection heating element	Closed
Grill; after convection heating element backed up has stopped	Open
Dual (Microwave and Convection)	Closed
Dual (Microwave and Grill) Open	Open
Fire sensing condition Closed	Closed

CHAPTER 7. TROUBLESHOOTING GUIDE

[1] FOREWORD

When troubleshooting the microwave oven, it is helpful to follow the Sequence of Operation in performing the checks.

Many of the possible causes of trouble will require that a specific test be performed. These tests are given a procedure letter which will be found in the "Test Procedure" section.

IMPORTANT:

If the oven becomes inoperative because of a blown fuse F2 (F8A) in the monitored latch switch SW1 - monitor switch SW3 circuit, check the monitored latch switch SW1 and monitor switch SW3 before replacing the noise filter (fuse F2 (F8A)).

CHAPTER 8. TEST PROCEDURES

[1] Procedure A: MAGNETRON TEST

NEVER TOUCH ANY PART IN THE CIRCUIT WITH YOUR HAND OR AN INSULATED TOOL WHILE THE OVEN IS IN OPERATION.

CARRY OUT 3D CHECKS.

Isolate the magnetron from the high voltage circuit by removing all leads connected to the filament terminal.

To test for an open circuit filament use an ohmmeter to make a continuity test between the magnetron filament terminals, the meter should show a reading of less than 1 ohm.

To test for a short circuit filament to anode condition, connect ohmmeter between one of the filament terminals and the case of the magnetron (ground). This test should be indicated an infinite resistance. If a low or zero resistance reading is obtained then the magnetron should be replaced.

MICROWAVE OUTPUT POWER (IEC60705)

The following test procedure should be carried out with the microwave oven in a fully assembled condition (outer case fitted). Microwave output power from the magnetron can be measured by IEC test procedure, i.e. it can be measured by using water load how much it can be absorbed by the water load. To measure the microwave output power in the microwave oven, the relation of calorie and watt is used. When P(W) heating works for t(second), approximately $P \times t / 4.187$ calorie is generated. On the other hand, if the temperature of the water with V(ml) rises ΔT ($^{\circ}\text{C}$) during this microwave heating period, the calorie of the water is $v \times \Delta T$.

The formula is as follows;	
$P \times t / 4.187 = V \times \Delta T + 0.55 \times mc (T2-T0)/4.187$	$P (W) = 4.187 \times V \times \Delta T / t + 0.55 \times mc (T2-T0)/t$
Our condition for water load is as follows:	
Room temperature (T0) around 20°C	Power supply VoltageRated voltage
Water load 1000 g	Initial temperature (T1) 10±1°C
Heating time 47 sec.	Mass of container (mc) 330 g
T2 Final Temperature	$\Delta T = T2 - T1$ $P = 90 \times \Delta T + 0.55 \times mc (T2-T0)/47$

Measuring condition:

1) Container

The water container must be a cylindrical borosilicate glass vessel having a maximum material thickness of 3 mm and an outside diameter of approximately 190 mm.

2) Temperature of the oven and vessel

The oven and the empty vessel are at ambient temperature prior to the start of the test.

3) Temperature of the water

The initial temperature of the water is (10±2) $^{\circ}\text{C}$

4) Select the initial and final water temperature so that the maximum difference between the final water temperature and the ambient temperature is 5°C.

5) Select stirring devices and measuring instruments in order to minimize addition or removal of heat.

6) The graduation of the thermometer must be scaled by 0.1°C at minimum and an accurate thermometer.

7) The water load must be (1000±5) g.

8) "t" is measured while the microwave generator is operating at full power. Magnetron filament heat-up time is not included.

NOTE: The operation time of the microwave oven is "t + 3" sec. 3 sec. is magnetron filament heat-up time.

Measuring method:

1) Measure the initial temperature of the water before the water is added to the vessel.

(Example: The initial temperature T1 = 11°C)

2) Add the 1 litre water to the vessel.

3) Place the load on the centre of the shelf.

4) Operate the microwave oven at 100% for the temperature of the water rises by a value ΔT of 10°C.

5) Stir the water to equalize temperature throughout the vessel.

6) Measure the final water temperature. (Example: The final temperature T2 = 21°C)

7) Calculate the microwave power output P in watts from above formula.

Room temperature	To = 21°C
Initial temperature	T1 = 11°C
Temperature after (47 + 3) = 50 sec	T2 = 21°C
Temperature difference Cold-Warm ($\Delta T = T2 - T1$)	$\Delta T = 10^{\circ}\text{C}$
Measured output power	
The equation is "P = 90 x ΔT "	$P = 90 \times 10^{\circ}\text{C} = 900 \text{ Watts}$

JUDGEMENT: The measured output power should be at least ± 15 % of the rated output power.

CAUTION: 1°C CORRESPONDS TO 90 WATTS. REPEAT MEASUREMENT IF THE POWER IS INSUFFICIENT.

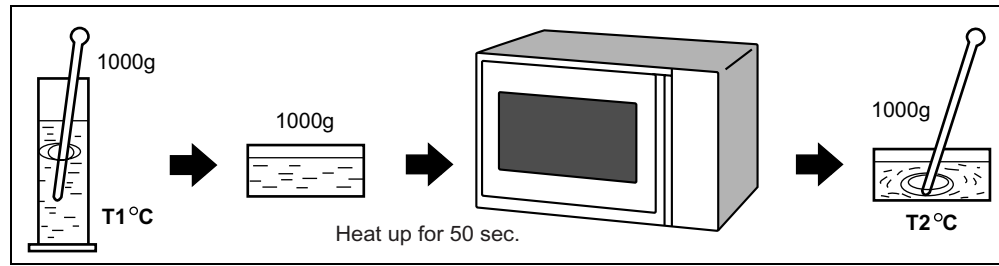

[2] Procedure B: HIGH VOLTAGE TRANSFORMER TEST

WARNING: High voltages and large currents are present at the secondary winding and filament winding of the power transformer. It is very dangerous to work near this part when the oven is on. NEVER make any voltage measurements of the high-voltage circuits, including the magnetron filament.

1. CARRY OUT 3D CHECKS.
2. Disconnect the leads to the primary winding of the high voltage transformer. Disconnect the filament and secondary winding connections from the rest of the HV circuitry. Using an ohmmeter, set on a low range, it is possible to check the continuity of all three winding. The following readings should be obtained:
 - a. Primary winding ----- approximately 1.9Ω
 - b. Secondary winding ----- approximately 123Ω
 - c. Filament winding ----- less than 1Ω

If the readings obtained are not stated as above, then the high voltage transformer is probably faulty and should be replaced.

3. Also, the high voltage transformer has the thermal cut-out in the primary coil. The thermal cut-out will open when the temperature of the thermal cut-out in the primary coil reaches approximately 150°C . The thermal cut-out resets automatically at 130°C . If an ohmmeter indicates an open circuit under normal condition, replace the high voltage transformer because the primary coil (thermal cut-out) has opened. An open primary coil (thermal cut-out) indicates overheating of the high voltage transformer. Check for restricted air flow to the high voltage transformer, especially the ventilation opening.
4. CARRY OUT 4R CHECKS.

[3] Procedure C: HIGH VOLTAGE RECTIFIER TEST

CARRY OUT 3D CHECKS.

Isolate the high voltage rectifier assembly from the HV circuit. The high voltage rectifier can be tested using an ohmmeter set to its highest range. Connect the ohmmeter across the terminal B+C of the high voltage rectifier and note the reading obtained. Reverse the meter leads and note this second reading. The normal resistance is infinite in one direction and more than $100 \text{ k}\Omega$ in the other direction.

CARRY OUT 4R CHECKS.

ASYMMETRIC RECTIFIER TEST

CARRY OUT 3D CHECKS.

Isolate the high voltage rectifier assembly from the HV circuit. The asymmetric rectifier can be tested using an ohmmeter set to its highest range across the terminals A+B of the asymmetric rectifier and note the reading obtained. Reverse the meter leads and note this second reading. If an open circuit is indicated in both directions then the asymmetric rectifier is good. If the asymmetric rectifier is shorted in either direction, then the asymmetric rectifier is faulty and must be replaced with high voltage rectifier. When the asymmetric rectifier is defective, check whether magnetron, high voltage rectifier, high voltage wire or filament winding of the high voltage transformer is shorted.

CARRY OUT 4R CHECKS.

NOTE: FOR MEASUREMENT OF THE RESISTANCE OF THE RECTIFIER, THE BATTERIES OF THE MEASURING INSTRUMENT MUST HAVE A VOLTAGE AT LEAST 6 VOLTS, BECAUSE OTHERWISE AN INFINITE RESISTANCE MIGHT BE SHOWN IN BOTH DIRECTIONS.

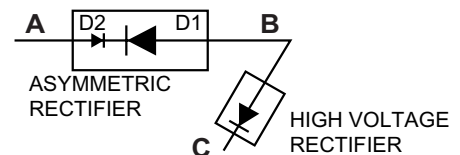

[4] Procedure D: HIGH VOLTAGE CAPACITOR TEST

CARRY OUT 3D CHECKS.

1. Isolate the high voltage capacitor from the circuit.
2. Continuity check must be carried out with measuring instrument which is set to the highest resistance range.
3. A normal capacitor shows continuity for a short time (kick) and then a resistance of about $10 \text{ M}\Omega$ after it has been charged.
4. A short-circuited capacitor shows continuity all the time.
5. An open capacitor constantly shows a resistance about $10 \text{ M}\Omega$ because of its internal $10 \text{ M}\Omega$ resistance.
6. When the internal wire is opened in the high voltage capacitor shows an infinite resistance.
7. The resistance across all the terminals and the chassis must be infinite when the capacitor is normal.

R939(W)

If incorrect reading are obtained, the high voltage capacitor must be replaced.

CARRY OUT 4R CHECKS.

[5] Procedure E: SWITCH TEST

CARRY OUT 3D CHECKS.

Isolate the switch to be tested and using an ohmmeter check between the terminals as described in the following table.

Table: Terminal Connection of Switch

Plunger Operation	Common terminal to Normally open terminal	Common terminal to Normally close terminal
Released	Open circuit	Short circuit
Depressed	Short circuit	Open circuit.

If incorrect readings are obtained, make the necessary switch adjustment or replace the switch.

CARRY OUT 4R CHECKS.

[6] Procedure F: THERMISTOR TEST

CARRY OUT 3D CHECKS.

Disconnect the connector B from CPU unit. Measure the resistance of the thermistor with an ohmmeter. Connect the ohmmeter leads to Pin No's C1 and C3 of the thermistor harness.

Room Temperature	Resistance
20°C - 30°C	Approximately 359.9 kΩ - 152 kΩ

If the meter does not indicate above resistance, replace the thermistor.

CARRY OUT 4R CHECKS.

[7] Procedure G: THERMAL CUT-OUT TEST

CARRY OUT 3D CHECKS.

Disconnect the leads from the terminals of the thermal cut-out. Then using an ohmmeter, make a continuity test across the two terminals as described in the below.

Table: Thermal Cut-out Test

Parts Name	Temperature of "ON" condition (closed circuit).	Temperature of "OFF" condition (open circuit).	Indication of ohmmeter (When room temperature is approx. 20°C.)
Thermal cut-out <u>TC1</u> 125°C	This is not resetable type.	Above 125°C	Closed circuit
Thermal cut-out <u>TC2</u> 170°C	Cuts back in at 155°C.	Above 170°C	Closed circuit
Thermal cut-out <u>TC3</u> 170°C	Cuts back in at 155°C.	Above 170°C	Closed circuit

If incorrect readings are obtained, replace the thermal cut-out.

An open circuit thermal cut-out (MG) TC1 indicates that the magnetron has overheated, this may be due to restricted ventilation, cooling fan failure.

An open circuit thermal cut-out (GRILL) TC2 indicates that the oven cavity has overheated, this may be due to no load operation.

An open circuit thermal cut-out (CONV.) TC3 indicates that the convection fan winding has overheated, this may be due to restricted ventilation or locked cooling fan or locked convection fan motor.

CARRY OUT 4R CHECKS.

[8] Procedure H: MOTOR WINDING TEST

CARRY OUT 3D CHECKS.

Disconnect the leads from the motor. Using an ohmmeter, check the resistance between the two terminals as described in the table below.

Table: Resistance of Motor

Motors	Resistance
Fan motor	Approximately 398.9 Ω
Turntable motor	Approximately 14.7 kΩ
Convection fan motor	Approximately 183.7 kΩ
Dumper motor	Approximately 14.7 kΩ

If incorrect readings are obtained, replace the motor.

CARRY OUT 4R CHECKS.

[9] Procedure I: NOISE FILTER TEST

CARRY OUT 3D CHECKS.

Disconnect the leads from the terminals of the noise filter. Using an ohmmeter, check between the terminals as described in the following table.

MEASURING POINT	INDICATION OF OHMMETER
Between N and L	Approx. 680 k Ω
Between terminal N and WHITE	Short circuit
Between terminal L and RED	Short circuit

If incorrect readings are obtained, replace the noise filter unit.

CARRY OUT 4R CHECKS.

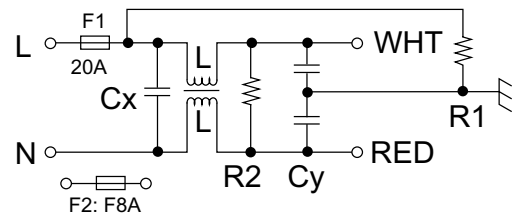

L (min)	Cx \pm 20%	Cy \pm 20%	R1	R2
1.0mH	0.22 μ F	4700pF	10 M Ω	680k Ω

[10] Procedure J: BLOWN FUSE (F1) 20A

CARRY OUT 3D CHECKS.

If the fuse F1 20A is blown, there is a shorts or grounds in electrical parts or wire harness. Check them and replace the defective parts or repair the wire harness.

CARRY OUT 4R CHECKS.

CAUTION: Only replace fuse with the correct value replacement.

[11] Procedure K: BLOWN FUSE (F2) 8A (NOISE FILTER)

CARRY OUT 3D CHECKS.

- If the fuse F2 8A is blown when the door is opened, check the monitored latch switch SW1 and monitor switch SW3.
- If the fuse F2 8A is blown by incorrect door switching replace the defective switch(es) and the noise filter.
- If the fuse F2 8A is blown, there could be shorts in the asymmetric rectifier or there is a ground in wire harness. A short in the asymmetric rectifier may be occurred due to short or ground in H.V. rectifier, magnetron, high voltage transformer or H.V. wire. Check them and replace the defective parts or repair the wire harness.

CARRY OUT 4R CHECKS.

CAUTION: REPLACE NOISE FILTER.

[12] Procedure L: GRILL HEATING ELEMENTS (TOP) AND CONVECTION HEATING ELEMENT TEST

CARRY OUT 3D CHECKS.

Before carrying out the following tests make sure the heating element is cool completely.

1. Resistance of heater.

Disconnect the wire leads to the heating element to be tested. Using ohmmeter with low resistance range. Check the resistance across the terminals of the heating element as described in the following table.

Table: Resistance of heater

Parts name	Resistance
Grill heating elements <u>GH</u> (Top)	Approximately 37.4 Ω - 39.7 Ω [(18.7 Ω - 19.85 Ω) x 2]
Convection heating elements <u>CH</u>	Approximately 34.09 Ω - 36.72 Ω

2. Insulation resistance.

Disconnect the wire leads to the heating element to be tested. Check the insulation resistance between the element terminal and cavity using a 500V - 100M Ω insulation tester. The insulation resistance should be more than 10 M Ω in the cold start.

If the results of above test 1 and/or 2 are out of above specifications, the heating element is probably faulty and should be replaced.

CARRY OUT 4R CHECKS.

[13] Procedure M: CONTROL PANEL ASSEMBLY TEST

The control panel consists of circuits including semiconductors such as LSI, ICs, etc. Therefore, unlike conventional microwave ovens, proper maintenance can not be performed with only a voltmeter and ohmmeter.

In this service manual, the control panel assembly is divided into two units, Control Unit and Jog and Switch Unit, and also the control unit is divided into two units, CPU unit and Power unit, and troubleshooting by replacement is described according to the symptoms indicated.

- Jog and Switch Unit Note: Check Jog and Switch unit wire harness connection before replacement.

The following symptoms indicate a defective Jog and Switch unit. Replace the Jog and Switch unit.

- Tact switch
 - When touching the buttons, a certain button produces no signal at all.

R939(W)

- b) When touching the buttons, sometimes a button produces no signal.
 - 2) Potentiometer
 - a) When rotating the potentiometer, the cooking mode can not be selected.
 - 3) Encoder
 - a) When rotating the encoder, the cooking time or the weight of food can not be entered.
2. Control Panel

The following symptoms indicate a defective control unit. Before replacing the control unit, perform the Jog and Switch unit test (Procedure N) to determine if control unit is faulty.

- 1) In connection with buttons
 - a) When touching the buttons, a certain group of buttons do not produce a signal.
 - b) When touching the buttons, no buttons produce a signal.
- 2) In connection with indicators
 - a) At a certain digit, all or some segments do not light up.
 - b) At a certain digit, brightness is low.
 - c) Only one indicator does not light up.
 - d) The corresponding segments of all digits do not light up; or they continue to light up.
 - e) Wrong figure appears.
 - f) A certain group of indicators do not light up.
 - g) The figure of all digits flicker.
- 3) 2-3 Other possible troubles caused by defective control unit.
 - a) Buzzer does not sound or continues to sound.
 - b) Clock does not operate properly.
 - c) Cooking is not possible.
 - d) Proper temperature measurement is not obtained.

[14] Procedure N: JOG AND SWITCH UNIT TEST

If the display fails to clear when the STOP button (tact switch SW13) is depressed, first verify the wire harness is marking good contact, verify that the door sensing switch (stop switch) operates properly; that is the contacts are closed when the door is closed and open when the door is open. If the door sensing switch (stop switch) is good, disconnect the wire harness that connects the Jog and Switch unit to the control unit and make sure the door sensing switch is closed (either close the door or short the door sensing switch connector). Use the Jog and Switch unit matrix indicated on the control panel schematic and place a jumper wire between the pins that correspond to the STOP button (tact switch SW13) marking momentary contact. If the control unit responds by clearing with a beep the Jog and Switch unit is faulty and must be replaced. If the control unit does not respond, it is a faulty and must be replaced. If a specific button does not respond, the above method may be used (after clearing the control unit) to determine if the control unit or Jog and Switch unit is at fault.

CARRY OUT 4R CHECKS.

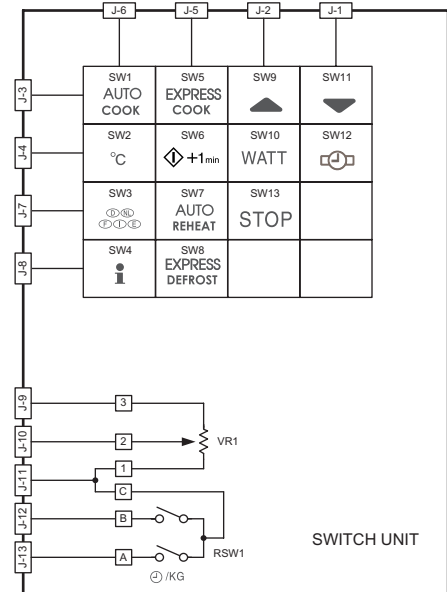

[15] Procedure O: RELAY TEST

CARRY OUT 3D CHECKS.

Remove the outer case and check voltage between Pin Nos. 1 and 3 of the 4 pin connector (E) on the control unit with an A.C. voltmeter. The meter should indicate 230 volts, if not check oven circuit.

Relay Test

Check voltage at the relay coil with a D.C. voltmeter during the microwave cooking operation, grill operation, convection operation or dual operation.

DC. voltage indicated Defective relay.

DC. voltage not indicated Check diode which is connected to the relay coil. If diode is good, control unit is defective.

RELAY SYMBOL	OPERATIONAL VOLTAGE	CONNECTED COMPONENTS
RY1	APPROX. 18.0V D.C.	Oven lamp / Turntable motor
RY2	APPROX. 18.0V D.C.	High voltage transformer
RY3	APPROX. 24.0V D.C.	Grill (Top) heating element
RY4	APPROX. 24.0V D.C.	Convection heating element
RY5	APPROX. 24.0V D.C.	Fan motor
RY6	APPROX. 24.0V D.C.	Touch control transformer
RY7	APPROX. 24.0V D.C.	Convection motor
RY8	APPROX. 24.0V D.C.	Damper motor

CARRY OUT 4R CHECKS.

[16] Procedure P: PROCEDURES TO BE TAKEN WHEN THE FOIL PATTERN ON THE PRINTED WIRING BOARD (PWB) IS OPEN

To protect the electronic circuits, this model is provided with a fine foil pattern added to the input circuit on the PWB, this foil pattern acts as a fuse. If the foil pattern is open, follow the troubleshooting guide given below for repair.

Problem: POWER ON, indicator does not light up.

CARRY OUT 3D CHECKS.

STEPS	OCCURRENCE	CAUSE OR CORRECTION
1	The rated AC voltage is not present between Pin No. 1 and 3 of the 4-pin connector (E).	Check supply voltage and oven power cord.
2	The rated AC voltage is present at primary side of low voltage transformer.	Low voltage transformer or secondary circuit defective. Check and replace power unit.
3	Only pattern at "a" is broken.	*Insert jumper wire J1 and solder.
4	Pattern at "a" and "b" are broken.	Replace power unit. (CARRY OUT <u>3D</u> CHECKS BEFORE REPAIR)

NOTE: *At the time of these repairs, make a visual inspection of the varistor for burning damage and examine the transformer with tester for the presence of layer short circuit (check primary coil resistance).

If any abnormal condition is detected, replace the power unit.

CARRY OUT 4R CHECKS.

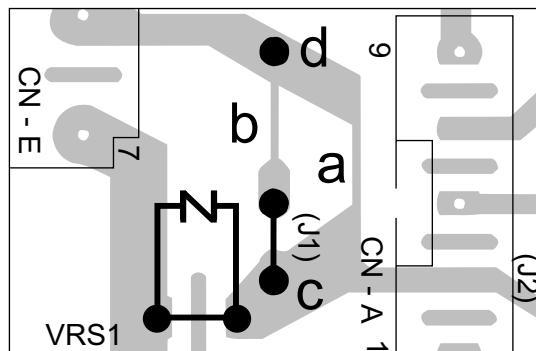

CHAPTER 9. TOUCH CONTROL PANEL ASSEMBLY

[1] OUTLINE OF TOUCH CONTROL PANEL

The control section consists of the following units as shown in the control panel circuit.

- (1) Jog and Switch Unit
- (2) Control Unit (The Control unit consists of Power unit and CPU unit.)

The principal functions of these units and signals communicated among them are explained below.

1. Jog and Switch Unit

- 1) Tact switch circuit

The jog and switch unit is composed of a matrix, signals generated in the LSI are sent to the jog and switch unit from P10, P11, P12, P13, P14, P15, P16 and P17. When a tact switch pad is touched, a signal is completed through the jog and switch unit and passed back to the LSI through P70, P71, P72 and P73 to perform the function that was requested.

- 2) Encoder

The encoder converts the signal generated by LSI into the pulse signal, and the pulse signal is returned to the LSI.

- 3) Potentiometer circuit

The circuit makes setting of the cooking mode by variable resistance.

2. Control Unit

Control unit consists of LSI, power source circuit, synchronizing signal circuit, ACL circuit, buzzer circuit, relay circuit, temperature measurement circuit, indicator circuit and back light circuit.

- 1) LSI

This LSI controls the temperature measurement signal, tact switch strobe signal, relay driving signal for oven function and indicator signal.

- 2) Power Source Circuit

This circuit generates voltage necessary in the control unit.

Symbol	Voltage	Application
--------	---------	-------------

VC	-5.2V	LSI(IC1)
----	-------	----------

- 3) Synchronizing Signal Circuit

The power source synchronizing signal is available in order to compose a basic standard time in the clock circuit. It accompanies a very small error because it works on commercial frequency.

- 4) ACL

A circuit to generate a signal which resets the LSI to the initial state when power is supplied.

- 5) Buzzer Circuit

The buzzer is responsive to signals from the LSI to emit audible sounds (key touch sound and completion sound).

- 6) Door Sensing Switch (Stop Switch)

A switch to "tell" the LSI if the door is open or closed.

- 7) Relay Circuit

To drive the magnetron, grill heating element, convection heating element, convection motor, fan motor, turntable motor, damper motor, touch control transformer and light the oven lamp.

- 8) Back Light Circuit

A circuit to drive the back light (Light emitting diodes LD10 - LD19).

- 9) Indicator Circuit

This circuit consists 40-segments and 16-common electrodes using a Liquid Crystal Display.

The Liquid Crystal Display (LCD) is drive by LCD driver IC3.

- 10)Temperature Measurement Circuit: (OVEN THERMISTOR)

The temperature in the oven cavity is sensed by the thermistor. The variation of resistance according to sensed temperature is detected by the temperature measurement circuit and the result applied to LSI. The LSI uses this information to control the relay and display units.

- 11)Damper Switch

A switch to tell the LSI if the damper is open or close.

[2] SERVICING FOR TOUCH CONTROL PANEL

1. Precautions for Handling Electronic Components

This unit uses CMOS LSI in the integral part of the circuits. When handling these parts, the following precautions should be strictly followed. CMOS LSI have extremely high impedance at its input and output terminals. For this reason, it is easily influenced by the surrounding high voltage power source, static electricity charge in clothes, etc., and sometimes it is not fully protected by the built-in protection circuit.

In order to protect CMOS LSI.

- 1) When storing and transporting, thoroughly wrap them in aluminium foil. Also wrap PW boards containing them in aluminium foil.
- 2) When soldering, ground the technician as shown in the figure and use grounded soldering iron and work table.

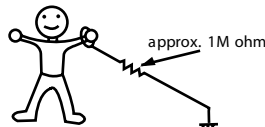

2. Servicing of Touch Control Panel

We describe the procedures to permit servicing of the touch control panel of the microwave oven and the precautions you must take when doing so. To perform the servicing, power to the touch control panel is available either from the power line of the oven itself or from an external power source.

1. Servicing the touch control panel with power supply of the oven:

CAUTION: THE HIGH VOLTAGE TRANSFORMER OF THE MICROWAVE OVEN IS STILL LIVE DURING SERVICING AND PRESENTS A HAZARD.

Therefore, before checking the performance of the touch control panel,

- 1) Disconnect the power supply cord, and then remove outer case.
- 2) Open the door and block it open.
- 3) Discharge high voltage capacitor.
- 4) Disconnect the leads to the primary of the power transformer.
- 5) Ensure that these leads remain isolated from other components and oven chassis by using insulation tape.

6) After that procedure, re-connect the power supply cord.

After checking the performance of the touch control panel,

- 1) Disconnect the power supply cord.
- 2) Open the door and block it open.
- 3) Re-connect the leads to the primary of the power transformer.
- 4) Re-install the outer case (cabinet).
- 5) Re-connect the power supply cord after the outer case is installed.
- 6) Run the oven and check all functions.
 - a) On some models, the power supply cord between the touch control panel and the oven itself is so short that the two can't be separated. For those models, check and repair all the controls (sensor-related ones included) of the touch control panel while keeping it connected to the oven.
 - b) On some models, the power supply cord between the touch control panel and the oven proper is long enough that they may be separated from each other. For those models, therefore, it is possible to check and repair the controls of the touch control panel while keeping it apart from the oven proper; in this case you must short both ends of the door sensing switch (on PWB) of the touch control panel with a jumper, which brings about an operational state that is equivalent to the oven door being closed. As for the sensor-related controls of the touch control panel, checking them is possible if the dummy resistor(s) with resistance equal to that of the controls are used.

2. Servicing the touch control panel with power supply from an external power source:

Disconnect the touch control panel completely from the oven proper, and short both ends of the door sensing switch (on PWB) of the touch control panel, which brings about an operational state that is equivalent to the oven door being closed. Connect an external power source to the power input terminal of the touch control panel, then it is possible to check and repair the controls of the touch control panel; it is also possible to check the sensor-related controls of the touch control panel by using the dummy resistor(s).

3. Servicing Tools

Tools required to service the touch control panel assembly.

- 1) Soldering iron: 60W
(It is recommended to use a soldering iron with a grounding terminal.)
- 2) Oscilloscope: Single beam, frequency range: DC - 10MHz type or more advanced model.
- 3) Others: Hand tools

4. Other Precautions

- 1) Before turning on the power source of the control unit, remove the aluminium foil applied for preventing static electricity.
- 2) Connect the connector of the key unit to the control unit being sure that the lead wires are not twisted.
- 3) After aluminium foil is removed, be careful that abnormal voltage due to static electricity etc. is not applied to the input or output terminals.
- 4) Attach connectors, electrolytic capacitors, etc. to PWB, making sure that all connections are tight.
- 5) Be sure to use specified components where high precision is required.

CHAPTER 10. PRECAUTIONS FOR USING LEAD-FREE SOLDER

1. Employing lead-free solder

The "Main PWB" of this model employs lead-free solder. This is indicated by the "LF" symbol printed on the PWB and in the service manual. The suffix letter indicates the alloy type of the solder.

Example:



Indicates lead-free solder of tin, silver and copper

2. Using lead-free wire solder

When repairing a PWB with the "LF" symbol, only lead-free solder should be used. (Using normal tin/lead alloy solder may result in cold soldered joints and damage to printed patterns.)

As the melting point of lead-free solder is approximately 40°C higher than tin/lead alloy solder, it is recommend that a dedicated bit is used, and that the iron temperature is adjusted accordingly.

3. Soldering

As the melting point of lead-free solder (Sn-Ag-Cu) is higher and has poorer wettability, (flow), to prevent damage to the land of the PWB, extreme care should be taken not to leave the bit in contact with the PWB for an extended period of time. Remove the bit as soon as a good flow is achieved. The high content of tin in lead free solder will cause premature corrosion of the bit. To reduce wear on the bit, reduce the temperature or turn off the iron when it is not required.

Leaving different types of solder on the bit will cause contamination of the different alloys, which will alter their characteristics, making good soldering more difficult. It will be necessary to clean and replace bits more often when using lead-free solder. To reduce bit wear, care should be taken to clean the bit thoroughly after each use.

CHAPTER 11. COMPONENT REPLACEMENT AND ADJUSTMENT PROCEDURE

[1] BEFORE OPERATING

WARNING AGAINST HIGH VOLTAGE:

Microwave ovens contain circuitry capable of producing very high voltage and current, contact with following parts may result in severe, possibly fatal, electric shock.

(Example)

High Voltage Capacitor, High Voltage Transformer, Magnetron, High Voltage Rectifier Assembly, High Voltage fuse, High Voltage Harness etc..

WARNING: Avoid possible exposure to microwave energy. Please follow the instructions below before operating the oven.

- | | |
|--|--|
| <ol style="list-style-type: none"> 1) Disconnect the power supply cord. 2) Visually check the door and cavity face plate for damage (dents, cracks, signs of arcing etc.). | <ol style="list-style-type: none"> 5) There are defective parts in the door interlock system. 6) There are defective parts in the microwave generating and transmission assembly. 7) There is visible damage to the oven. |
|--|--|
- Carry out any remedial work that is necessary before operating the oven.
- Do not operate the oven if any of the following conditions exist;
- | | |
|--|--|
| <ol style="list-style-type: none"> 1) Door does not close firmly. 2) Door hinge, support or latch hook is damaged. 3) The door gasket or seal is damaged. 4) The door is bent or warped. | <p>Do not operate the oven:</p> <ol style="list-style-type: none"> 1) Without the RF gasket (Magnetron). 2) If the wave guide or oven cavity are not intact. 3) If the door is not closed. 4) If the outer case (cabinet) is not fitted. |
|--|--|

WARNING FOR WIRING

To prevent an electric shock, take the following manners.

- | | |
|--|--|
| <ol style="list-style-type: none"> 1. Before wiring, <ol style="list-style-type: none"> 1) Disconnect the power supply cord. 2) Open the door and block it open. 3) Discharge the high voltage capacitor and wait for 60 seconds. 2. Don't let the wire leads touch to the following parts; <ol style="list-style-type: none"> 1) High voltage parts:
Magnetron, High voltage transformer, High voltage capacitor and High voltage rectifier assembly. 2) Hot parts:
Grill heating element, Convection heating element, Oven lamp, Magnetron, High voltage transformer and Oven cavity. | <ol style="list-style-type: none"> 3) Sharp edge:
Bottom plate, Oven cavity, Waveguide flange, Chassis support and other metallic plate. 4) Movable parts (to prevent a fault)
Fan blade, Fan motor, Switch, Turntable motor, Convection motor, convection fan and cooling fan. 3. Do not catch the wire leads in the outer case cabinet. 4. Insert the positive lock connector certainly until its pin is locked. And make sure that the wire leads should not come off even if the wire leads is pulled. 5. To prevent an error function, connect the wire leads correctly, referring to the Pictorial Diagram. |
|--|--|

Please refer to 'OVEN PARTS, CABINET PARTS, CONTROL PANEL PARTS, DOOR PARTS', when carrying out any of the following removal procedures:

[2] OUTER CASE REMOVAL

To remove the outer case, procedure as follows.

- | | |
|---|--|
| <ol style="list-style-type: none"> 1. Disconnect the oven from power supply. 2. Open the oven door and wedge it open. 3. Remove the one (1) screw holding the air duct to the oven cavity rear plate. 4. Remove the air duct. 5. Remove the nine (9) screws from rear and along the side edge of case. | <ol style="list-style-type: none"> 6. Slide the entire case back about 3 cm to free it from retaining clips on the cavity face plate. 7. Lift the entire case from the oven. 8. Discharge the H.V. capacitor before carrying out any further work. 9. Do not operate the oven with the outer case removed. <p>NOTE: Step 1, 2 and 8 form the basis of the <u>3D</u> checks.</p> <p>CAUTION: DISCHARGE HIGH VOLTAGE CAPACITOR BEFORE TOUCHING ANY OVEN COMPONENT OR WIRING.</p> |
|---|--|

[3] HIGH VOLTAGE COMPONENTS REMOVAL

(HIGH VOLTAGE CAPACITOR AND HIGH VOLTAGE RECTIFIER ASSEMBLY)

To remove the components, proceed as follows.

1. CARRY OUT 3D CHECKS.
2. Disconnect the filament lead of the high voltage transformer and the high voltage wire of the high voltage transformer from the high voltage capacitor.
3. Disconnect the high voltage wire from the magnetron.

R939(W)

4. Remove one (1) screw holding earth side terminal of the high voltage rectifier assembly to the base plate through the capacitor holder.
5. Release the capacitor holder from the base plate.
6. Remove the high voltage capacitor from the capacitor holder.
7. Disconnect the high voltage rectifier assembly from the high voltage capacitor.

[4] HIGH VOLTAGE TRANSFORMER REMOVAL

To remove the components, proceed as follows.

1. CARRY OUT 3D CHECKS.
2. Disconnect the main wire harness from the high voltage transformer.
3. Disconnect the filament leads and high voltage wire of high voltage transformer from high voltage capacitor and the magnetron.

[5] MAGNETRON REMOVAL

1. CARRY OUT 3D CHECKS.
2. Disconnect the H.V. wire and filament lead of the transformer from the magnetron.
3. Carefully remove two (2) screws holding the magnetron to the waveguide, when removing the screws hold the magnetron to prevent it from falling.
4. Remove the one (1) screw holding the magnetron to the chassis support.

[6] CONTROL PANEL ASSEMBLY REMOVAL

1. CARRY OUT 3D CHECKS.
2. Disconnect the wire leads and the connectors from the power unit.
3. Remove the one (1) screw holding the control panel to the oven cavity face plate.
4. Remove the one (1) screw holding the earth wire to the oven cavity face plate.
5. Lift up the control panel assembly and pull it forward.
Now the control panel assembly is free.

Jog and Switch unit

6. Disconnect the connector CN-G from the CPU unit.

[7] FAN MOTOR REREPLACEMENT

1. REMOVAL

1. CARRY OUT 3D CHECKS.
2. Remove the one (1) screw holding the noise filter to the chassis support.
3. Release the noise filter from the tabs of the fan duct.
4. Remove the three(3) screw holding the chassis support to the oven cavity front flange, back plate, and the magnetron.
5. Remove the chassis support from the oven cavity.
6. Disconnect the wire leads from the fan duct.
7. Remove the one (1) screw holding the fan duct to the back plate.
8. Release the tabs of the fan duct from back plate.
9. Remove the fan duct from the oven.
10. Remove the fan blade from the fan motor shaft according to the following procedure.
 - i) Hold the edge of the rotor of the fan motor by using a pair of groove joint pliers.

8. Now, the high voltage rectifier assembly and the high voltage capacitor should be free.

CAUTION: WHEN REPLACING HIGH VOLTAGE RECTIFIER ASSEMBLY, ENSURE THAT THE CATHODE (EARTH) CONNECTION IS SECURELY FIXED TO THE BASE PLATE THROUGH THE CAPACITOR HOLDER WITH AN EARTHING SCREW.

4. Remove the two (2) screws holding the transformer to the base plate.
5. Remove the transformer.
6. Now the high voltage transformer is free.

5. Remove the magnetron from the waveguide with care so the magnetron antenna is not hit by any metal object around the antenna.
6. Now, the magnetron is free.

CAUTION: CAUTION: WHEN REPLACING THE MAGNETRON, BE SURE THE R.F. GASKET IS IN PLACE AND THE MAGNETRON MOUNTING SCREWS ARE TIGHTENED SECURELY.

7. Remove the four (4) screws holding the power unit to the control panel.
8. Remove the one (1) screw holding the LCD holder to the control panel.
9. Remove the control unit assembly (CPU unit and Power unit) from the control panel.
10. Remove the seven (7) screws holding the jog and switch unit to the control panel.
11. Remove the jog and switch unit from the control panel.
12. Now, the jog and switch unit is free.

CAUTION: • Make sure that no swarf from the rotor enters the gap between the rotor & stator of the fan motor.
• Avoid touch the coil of the fan motor with the pliers as the coil may become cut or damaged.
• Avoid deforming the bracket whilst using the pliers.

- ii) Remove the fan blade assembly from the shaft of the fan motor by pulling and rotating the fan blade with your hand.
- iii) Now, the fan blade is free.

CAUTION: Do not re-use the removed fan blade as the fixing hole may be oversized.

11. Remove the two (2) screws holding the fan motor to the fan duct.
12. Now, the fan motor is free.

2. INSTALLATION

1. Install the fan motor to the fan duct with the two (2) screws and nuts.
2. Install the fan blade to the fan motor shaft according to the following procedure.

- i) Hold the centre of the bracket which supports the shaft of the fan motor on a flat table.
- ii) Apply the screw lock tight into the hole (for shaft) of the fan blade.
- iii) Install the fan blade to the shaft of fan motor by pushing the fan blade with a small, light weight, ball peen hammer or rubber mallet.

CAUTION: • Do not hit the fan blade when installing because the bracket may be deformed.

- Make sure that the fan blade rotates smoothly after installation.
- Make sure that the axis of the shaft is not slanted.

3. Insert the tabs of the fan duct to the back plate.
4. Install the fan duct to the back plate with the one (1) screw.
5. Re-install the chassis support to the oven cavity with the four (4) screws.
6. Install the noise filter to the fan duct and the chassis support with the one (1) screw.
7. Re-connect the wire leads to the fan motor.

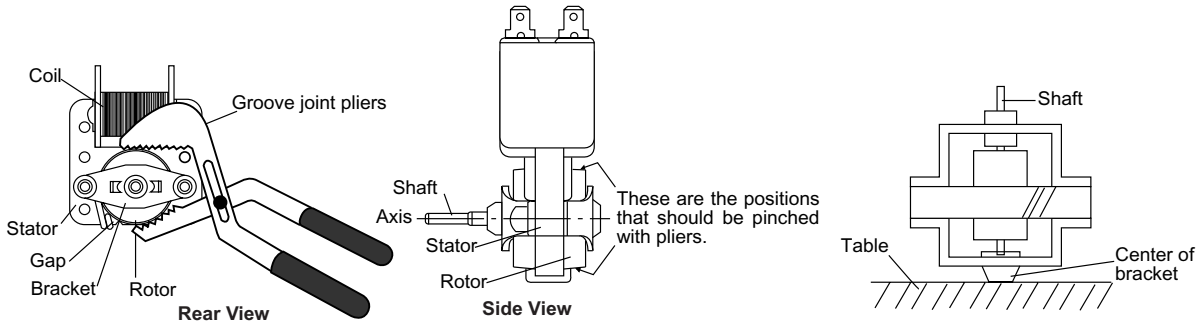

[8] TURNTABLE MOTOR REPLACEMENT

1. REMOVAL

1. Disconnect the oven from the power supply.
2. Remove the turntable and roller stay from the oven cavity.
3. Turn the oven over.
4. Cut the three (3) bridges holding the turntable motor cover to the base plate with cutting pliers as shown in Figure C-1(a).

CAUTION: DO NOT DROP THE TURNTABLE MOTOR COVER INTO THE OVEN AFTER CUTTING THE BRIDGES. BECAUSE IT WILL DAMAGE THE WIRE LEADS OF THE MOTOR AND IT IS DIFFICULT TO REMOVE IT OUT OF THE OVEN.

5. Remove the turntable motor cover from the base plate.
6. Disconnect the wire leads from the turntable motor.
7. Remove the two (2) screws holding the turntable motor to the oven cavity back plate.
8. Remove the turntable motor from the turntable motor angle. Now, the turntable motor is free.

2. REINSTALL

1. Remove the any sharp edges on the turntable motor cover and the base plate with the cutting pliers.
2. Re-install turntable motor by locating shaft onto coupling to the oven cavity base plate with the two (2) screws.
3. Re-connect the wire leads to the turntable motor.

4. Insert the one (1) tab of the turntable motor cover into the slit of the base plate as shown in Figure C-1(b).
5. Re-install the turntable motor cover to the base plate with the screw (XHPS740P08K00) as shown in Figure C-1(b).

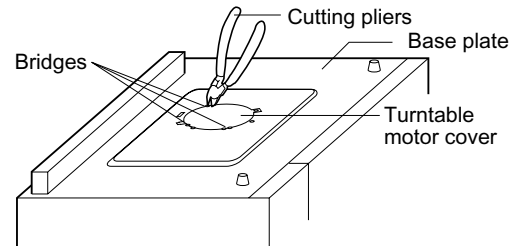

Figure C-1(a) Turntable Motor Cover Replacement

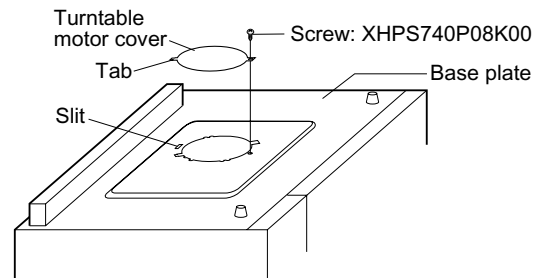

Figure C-1(b) Turntable Motor Cover reinstall

[9] CONVECTION MOTOR AND CONVECTION HEATING ELEMENT REMOVAL

1. CONVECTION UNIT ASSEMBLY REMOVAL

1. CARRY OUT 3D CHECKS.

Now, the outer case cabinet and the air duct should have been removed.

2. Remove the one (1) screw holding the earth wire of the power supply cord to the back plate.
3. Release the power supply cord from the back plate.

4. Remove the two (2) screws holding the rear barrier to the base plate.
5. Release the three (3) tabs of rear barrier from the base plate. And remove the rear barrier.
6. Remove the one (1) screw holding the back plate to the base plate.
7. Remove the one (1) screw holding the chassis support to the back plate.
8. Remove the one (1) screw holding the back plate to the air intake duct.

[12] POWER SUPPLY CORD REPLACEMENT

1. REMOVAL

1. CARRY OUT 3D CHECKS.
2. Remove the one (1) screw holding the green/yellow wire to the back plate.
3. Disconnect the leads of the power supply cord from the noise filter, referring to the Figure C-4(a).
4. Release the power supply cord from the rear cabinet.
5. Now, the power supply cord is free.

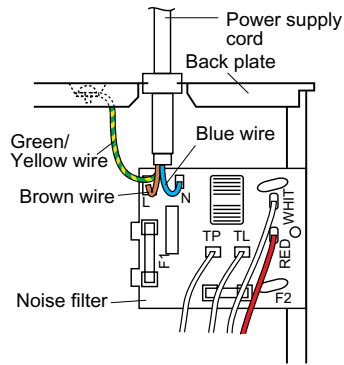

Figure C-4 (a) Replacement of Power Supply Cord

2. REINSTALL

1. Insert the moulding cord stopper of power supply cord into the square hole of the power angle, referring to the Figure C-4(b).
2. Install the earth wire lead of power supply cord to the back plate with one (1) screw and tight the screw.
3. Connect the brown and blue wire leads of power supply cord to the noise filter correctly, referring to the Pictorial Diagram.

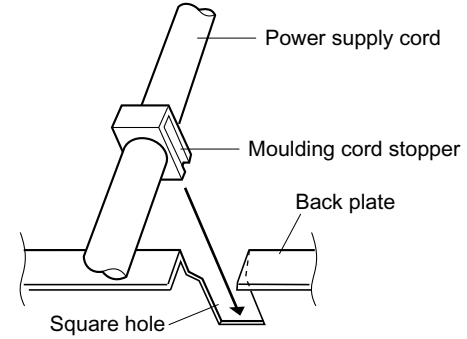

Figure C-4(b). Power Supply Cord Replacement

[13] GRILL HEATING ELEMENTS REMOVAL

1. CARRY OUT 3D CHECKS.
2. Disconnect wire leads from the thermal cut-out (GRILL).
3. Remove the two (2) screws holding the two (2) terminals of the main wire harness to the two (2) grill heating elements.
4. Remove the one (1) screw holding the exhaust duct to the oven cavity top plate.
5. Remove the exhaust duct from the oven cavity top plate.
6. By pushing the two (2) tabs holding the grill reflector to the oven cavity top plate, slide the grill reflector toward the magnetron. And then lift up the grill reflector and remove it.

7. Remove the one (1) screw holding the grill heater angle to the grill heater reflector.
8. Straighten the two (2) tabs of the grill heater angle and remove the grill heater angle from the grill reflector.
9. Remove the two (2) screws holding the earth plate to the two (2) grill heating elements.
10. Remove the two (2) grill heating elements from the grill reflector.
11. Now, the grill heating elements are free.

[14] MONITORED LATCH SWITCH, MONITOR SWITCH AND STOP SWITCH REMOVAL

1. CARRY OUT 3D CHECKS.
2. Remove the control panel assembly referring to "CONTROL PANEL ASSEMBLY REMOVAL".
3. Disconnect the leads from all switches.
4. Remove the two (2) screws holding the latch hook to the oven cavity.
5. Remove the latch hook.
6. Remove the switch(es) from the latch hook by pushing the retaining tab backwards slightly and turning the switch(es) on the post.
7. Now the switch(es) is free

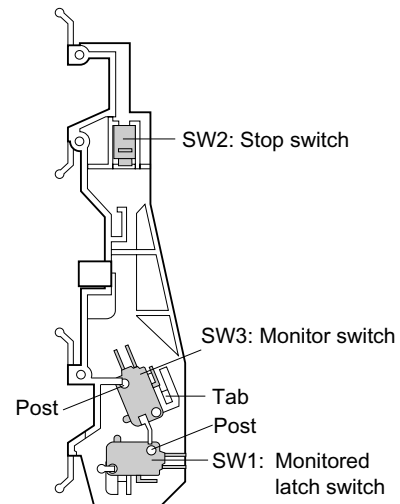

Figure C-5. Switches

[15] MONITORED LATCH SWITCH, STOP SWITCH AND MONITOR SWITCH ADJUSTMENT

1. Adjustment

If the monitored latch switch, stop switch and monitor switch do not operate properly due to a mis-adjustment, the following adjustment should be made.

1. CARRY OUT 3D CHECKS.
2. Loosen the two (2) screws holding the latch hook to the oven cavity front flange.
3. With the door closed, adjust the latch hook by moving it back and forward or up and down. In and out play of the door allowed by the latch hook should be less than 0.5 mm.

The horizontal position of the latch hook should be placed where the monitor switch has activated with the door closed. The vertical position of the latch hook should be placed where the monitored latch switch and stop switch have activated with the door closed.

4. Secure the screws with washers firmly.
5. Make sure of the all switches operation. If the latch head has not pushed the plungers of the monitor switch with door closed, adjust the latch hook position. At that time, the latch head should have pushed the plungers of the monitored latch switch and stop switch. If the latch head has not pushed the plungers of the monitored latch switch and stop switch with door closed, loose two (2) screws holding latch hook to oven cavity front flange and adjust the latch hook position.

2. After adjustment, make sure of following.

1. In and out play of door remains less than 0.5 mm when latched position. First check the latch hook position, pushing and pulling upper portion of the door toward the oven face. Then check the lower latch hook position, pushing and pulling lower portion of the door toward the oven face. Both results (play of the door) should be less than 0.5mm.

2. The contacts (COM-NO) of the stop switch and the monitored latch switch open within 1.8mm gap between right side of cavity face plate and door when door is opened.
3. When the door is closed, the contacts (COM-NO) of the stop switch close.
4. When the door is closed the contacts (COM-NC) of the monitor switch and monitored latch switch open. And the contacts (COM-NO) of their switches close.
5. Re-install outer case and check for microwave leakage around the door with an approved microwave survey meter. (Refer to Microwave Measurement Procedure.)

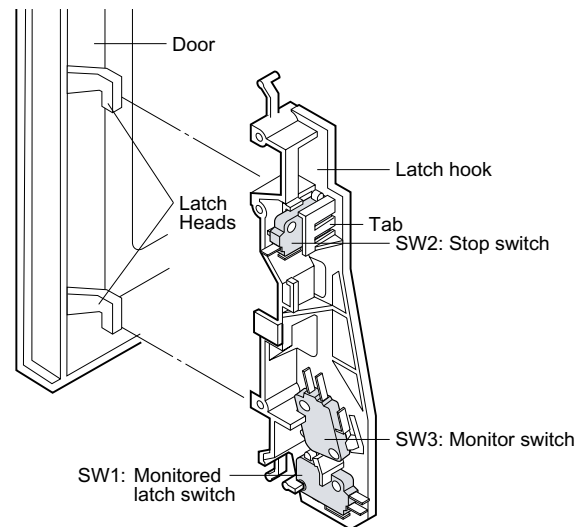

Figure C-6 Latch Switches Adjustment

[16] DOOR REPLACEMENT

1. REMOVAL

1. Disconnect the oven from the power supply.
2. Push the door slightly.
3. Remove the door stopper from the choke cover.
4. Lift the door upwards.
5. Now, door assembly is free from oven cavity.
6. Insert an putty knife (thickness of about 0.5mm) into the gap between the choke cover and door frame as shown in Figure C-7 to free engaging parts.
7. Release choke cover from door panel.
8. Now choke cover is free.

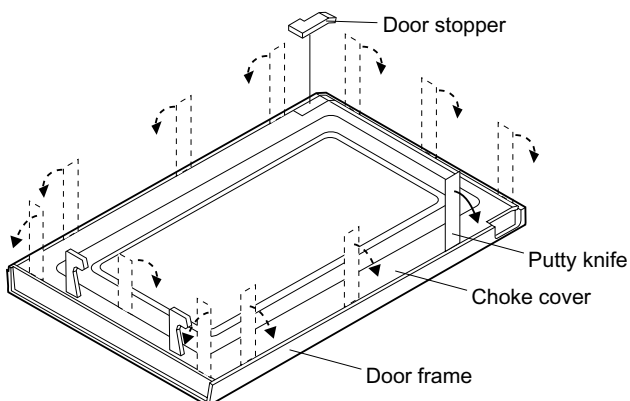

Figure C-7. Door Disassembly

DOOR PANEL

9. Remove the eight (8) screws holding the door panel to the door frame.
10. Now, door panel is free.

CAUTION: DO NOT DEFORM OR WARP THE TEETH OF COMB OF THE DOOR PANEL TO PREVENT MICROWAVE RADIATION EMISSION FROM THE DOOR.

LATCH HEAD AND SPRING

11. Slide latch head upward and remove it from door frame with releasing latch spring from door frame and latch head.
12. Now, latch head and latch spring are free.

DOOR HANDLE AND FRONT DOOR GLASS

13. Remove the two (2) screws holding the door handle and the glass stopper to the door frame.
14. Remove the door handle and the glass stopper from the door frame.
15. Slide the front door glass leftward and then slide downwards to release the tabs holding it.
16. Now, the front door glass is free

2. REINSTALLATION

1. Re-install the front door glass to the door frame as follows.
 - 1) Insert the upper edge of the front door glass into the tabs of the door frame.

- 2) Slide the front door glass downwards and insert the lower edge of the front door glass into the tabs of the door frame.
- 3) Slide the front door glass rightwards and insert the right edge of the front door glass into the tabs of the door frame.
2. Re-install the door handle and the glass stopper to the door frame as follows.
 - 1) Insert the door handle and the glass stopper to the door frame.
 - 2) Hold the door handle and the glass stopper to the door frame with the two (2) screws.
3. Re-install the latch spring to the latch head. Re-install the latch spring to the door frame. Re-install latch head to door frame.
4. Re-install door panel to door frame.
5. Hold the door panel to the door frame with eight (8) screws.
6. Re-install choke cover to door panel by clipping into position.
7. Locate door panel hinge pins into cavity hinge location holes.
8. Re-install the door stopper to the chock cover.

NOTE: **After any service to the door;**

- 1) **Make sure that the monitor switch, monitored latch switch and stop switch are operating properly. (Refer to chapter "Test Procedures".)**
- 2) **An approved microwave survey meter should be used to assure compliance with proper microwave radiation emission limitation standards. (Refer to Microwave Measurement Procedure.)**

3. After any service, make sure of the following:

1. Door latch heads smoothly catch latch hook through latch holes and that latch head goes through centre of latch hole.
2. Deviation of door alignment from horizontal line of cavity face plate is to be less than 1.0mm.

3. Door is positioned with its face pressed toward cavity face plate.
4. Check for microwave leakage around door with an approved microwave survey meter. (Refer to Microwave Measurement Procedure.)

NOTE: The door on a microwave oven is designed to act as an electronic seal preventing the leakage of microwave energy from oven cavity during cook cycle. This function does not require that door be air-tight, moisture (condensation)-tight or light-tight. Therefore, occasional appearance of moisture, light or sensing of gentle warm air movement around oven door is not abnormal and do not of themselves, indicate a leakage of microwave energy from oven cavity.

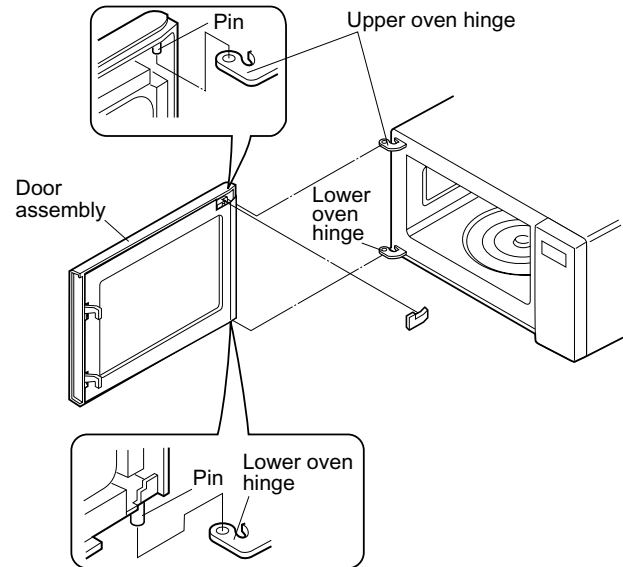

Figure C-8. Door Replacement

CHAPTER 12. MICROWAVE MEASUREMENT

After adjustment of door latch switches, monitor switch and door are completed individually or collectively, the following leakage test must be performed with a survey instrument and it must be confirmed that the result meets the requirements of the performance standard for microwave oven.

REQUIREMENT

The safety switch must prevent microwave radiation emission in excess of $5\text{mW}/\text{cm}^2$ at any point 5cm or more from external surface of the oven.

PREPARATION FOR TESTING

Before beginning the actual test for leakage, proceed as follows;

1. Make sure that the test instrument is operating normally as specified in its instruction booklet.

Important:

Survey instruments that comply with the requirement for instrumentations as prescribed by the performance standard for microwave ovens must be used for testing.

Recommended instruments are:

NARDA 8100

NARDA 8200

HOLADAY HI 1500

SIMPSON 380M

2. Place the oven tray into the oven cavity.
3. Place the load of $275 \pm 15\text{ml}$ of water initially at $20 \pm 5^\circ\text{C}$ in the centre of the oven tray. The water container should be a low form of 600 ml beaker with inside diameter of approx. 8.5cm and made of an electrically non-conductive material such as glass or plastic.
The placing of this standard load in the oven is important not only to protect the oven, but also to insure that any leakage is measured accurately.
4. Close the door and turn the oven ON with the timer set for several minutes. If the water begins to boil before the survey is completed, replace it with 275ml of cool water.
5. Move the probe slowly (not faster than $2.5\text{cm}/\text{sec.}$) along the gap.
6. The microwave radiation emission should be measured at any point of 5cm or more from the external surface of the oven.

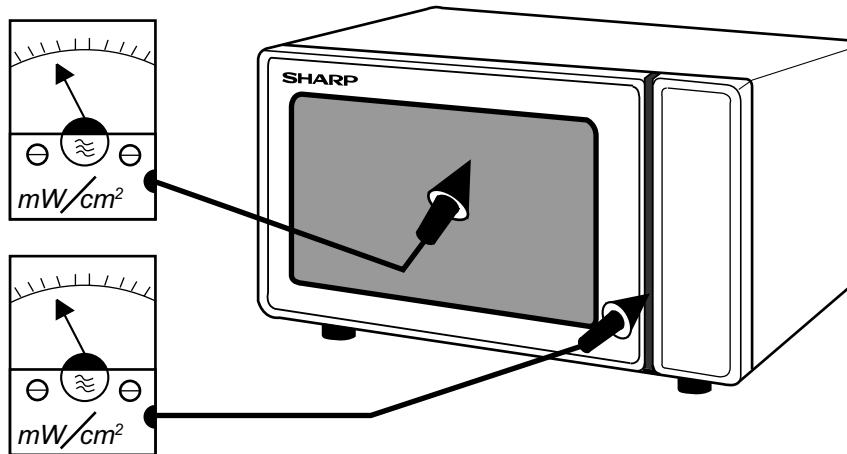

Microwave leakage measurement at 5 cm distance

CHAPTER 13. TEST DATA AT A GLANCE

PARTS	SYMBOL	VALUE / DATA
Fuse	F1	20A 250V
Fuse (Noise filter)	F2	F8A
Thermal cut-out	TC1	125°C Off
Thermal cut-out	TC2, TC3	170°C Off / 155°C On
Thermistor		Approx. 359.9 k Ω - 152 k Ω at 20°C - 30°C
Grill heating element	GH	Approx. 37.4 Ω - 39.7 Ω [(18.7 Ω - 19.85 Ω) x 2] / Insulation resistance > 10M Ω
Convection heating element	CH	Approx. 34.09 Ω - 36.72 Ω / Insulation resistance > 10M Ω
Oven lamp	OL	240 - 250V 25W
High voltage capacitor	C	AC 2100V 1.16 μ F
Magnetron	MG	Filament < 1 Ω / Filament - chassis ∞ ohm
High voltage transformer	T	Filament winding < 1 Ω Secondary winding Approx. 123 Ω Primary winding Approx. 1.9 Ω

WARNING: DISCONNECT THE PLUG WHEN MEASURING RESISTANCE

CHAPTER 14. CIRCUIT DIAGRAMS

[1] Oven Schematic

SCHEMATIC

NOTE: CONDITION OF OVEN

1. DOOR CLOSED.
2. PLUGGED IN OVEN.
3. NOTHING APPEARS ON DIS PLAY.

NOTE: "★" indicates components with potentials above 250V

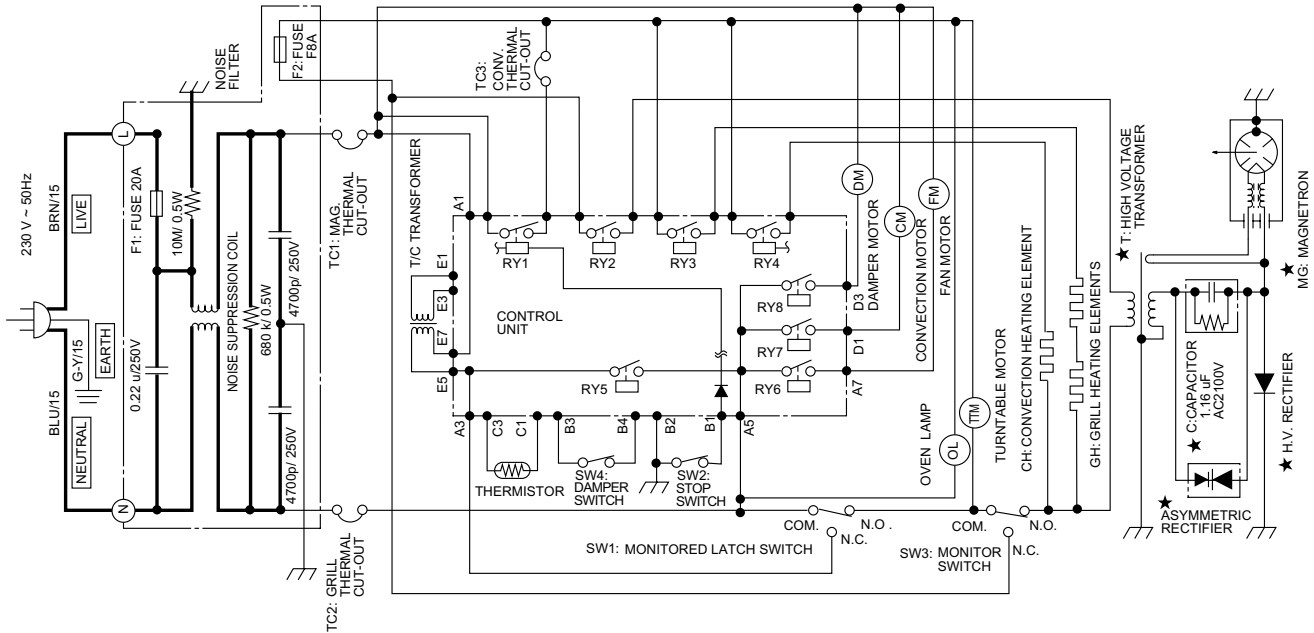

Figure O-1(a) Oven Schematic-OFF Condition right after the oven is plugged in.

SCHEMATIC

NOTE: CONDITION OF OVEN

1. DOOR CLOSED.
2. "SELECTED LANGUAGE" APPEARS ON DISPLAY.

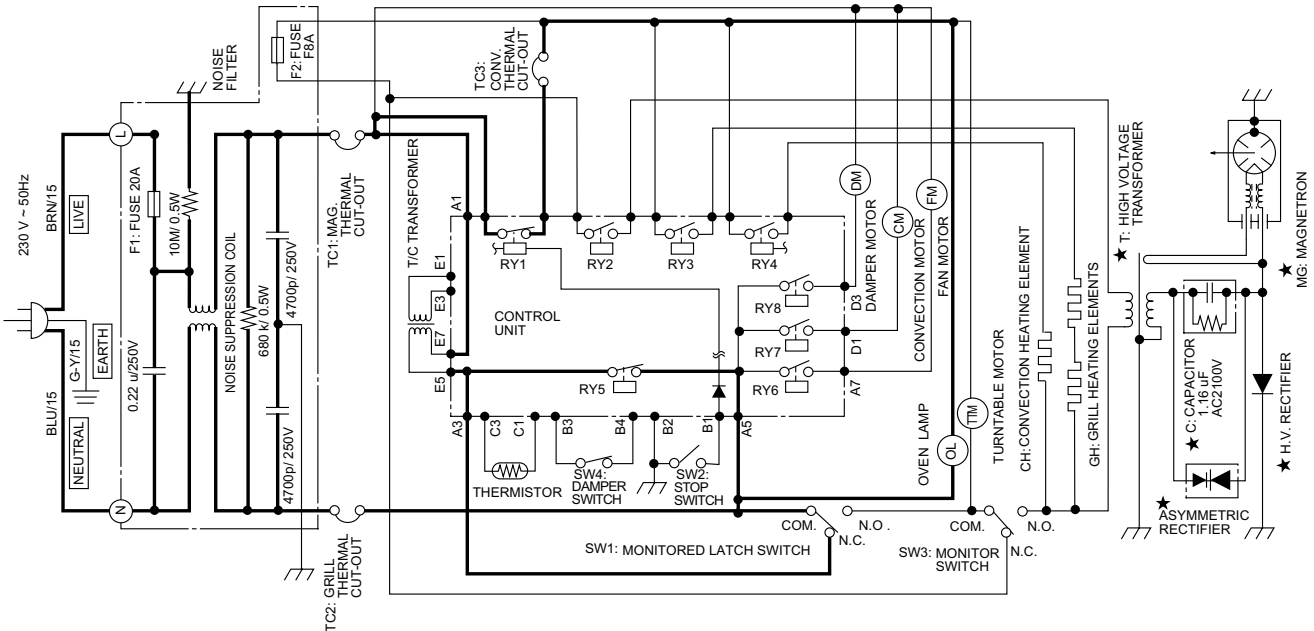
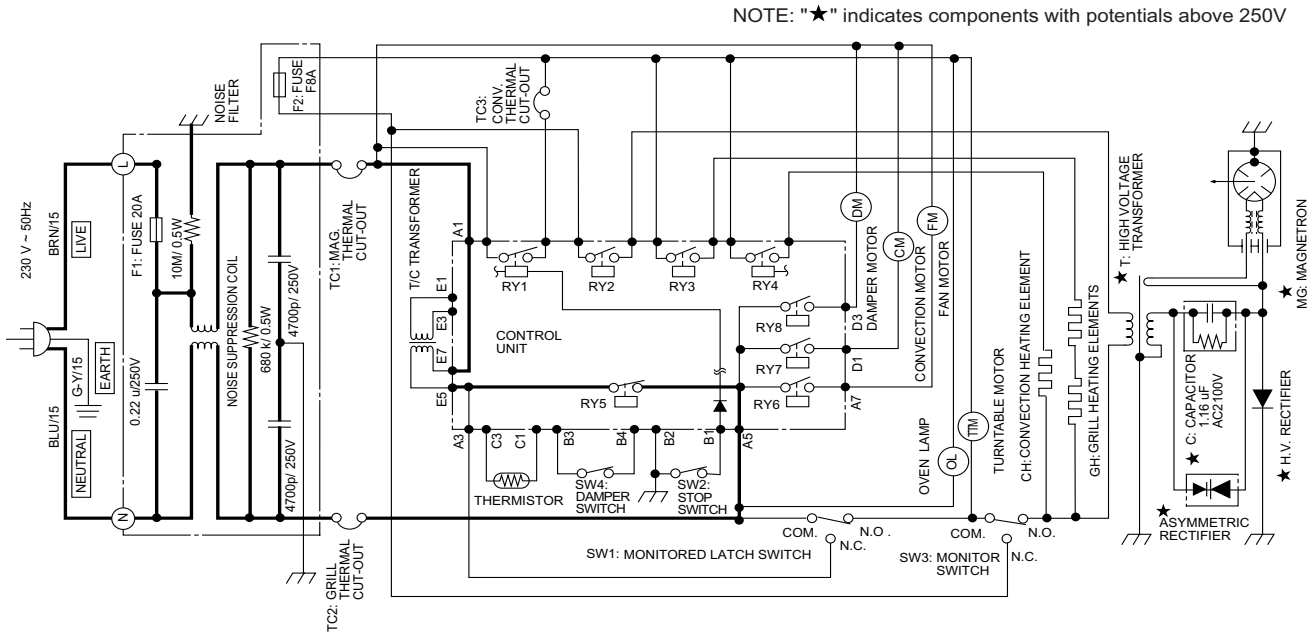

Figure O-1(b) Oven Schematic-OFF Condition when the oven door is opened.

SCHEMATIC

NOTE: CONDITION OF OVEN
 1. DOOR CLOSED.
 2 " . O" APPEARS ON DISPLAY.



NOTE: "★" indicates components with potentials above 250V

Figure O-1(c) Oven Schematic-OFF Condition after the oven door is closed.

SCHEMATIC

NOTE: CONDITION OF OVEN
 1. DOOR CLOSED.
 2. MICROWAVE MODE SET.
 3. COOKING TIME SET.
 4. STRAT BUTTON PRESSED.

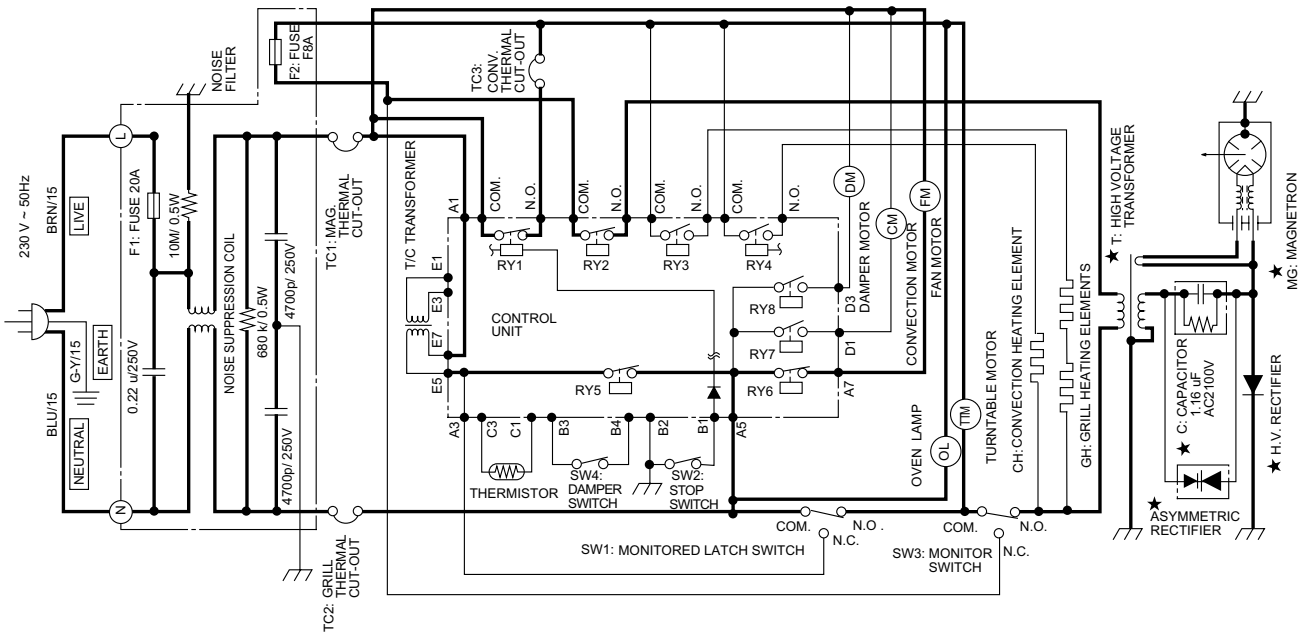

Figure O-2 Oven Schematic-Microwave cooking Condition

SCHMATIC

NOTE: CONDITION OF OVEN

1. DOOR CLOSED.
2. GRILL MODE SET.
3. COOKING TIME SET.
4. STRAT BUTTON PRESSED.

NOTE: "★" indicates components with potentials above 250V

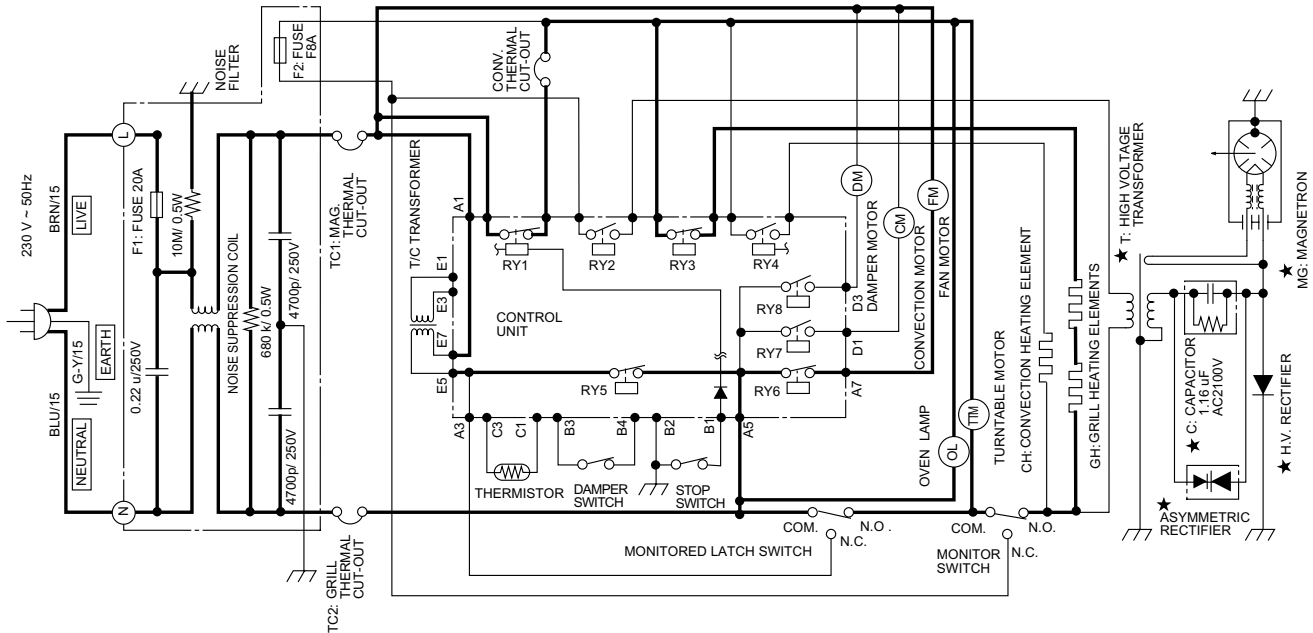

Figure O-3 Oven Schematic-Grill cooking Condition (TOP GRILL mode)

SCHMATIC

NOTE: CONDITION OF OVEN

1. DOOR CLOSED.
2. CONVECTION MODE SET.
3. COOKING TIME SET.
4. CONVECTION TEMPERATURE SELECTED.
5. STRAT BUTTON PRESSED.

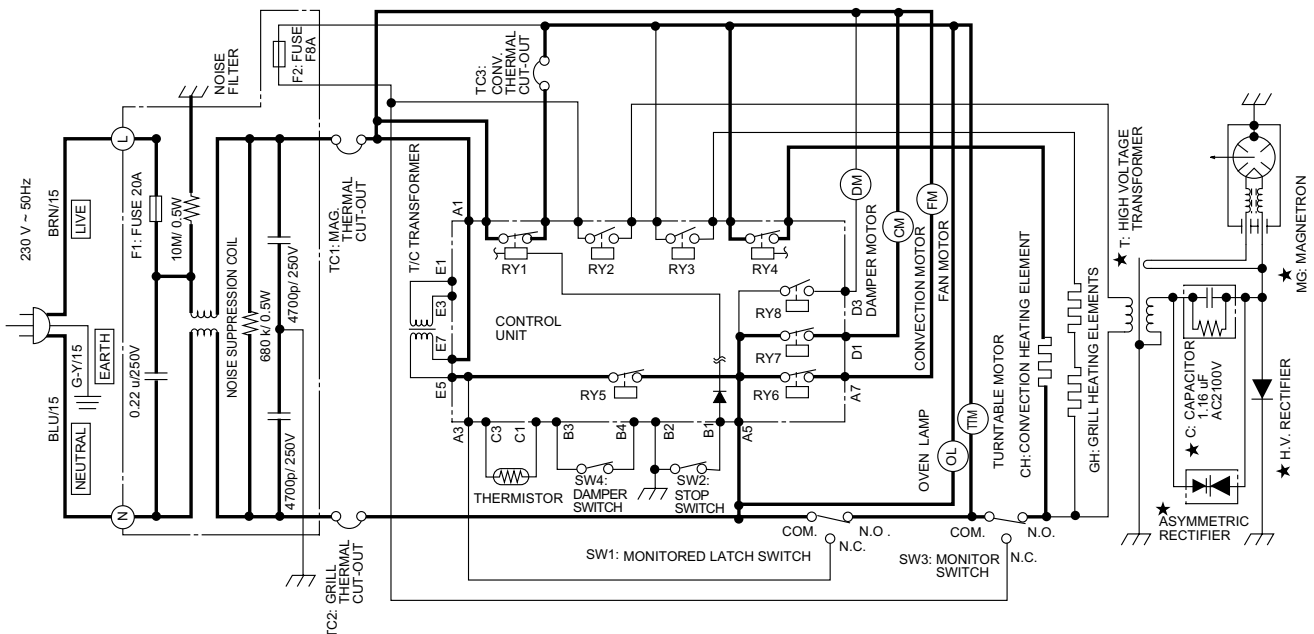

Figure O-4 Oven Schematic-Convection Condition

SCHEMATIC

NOTE: CONDITION OF OVEN

1. DOOR CLOSED.
2. DUAL1 MODE SET.
3. COOKING TIME SET.
4. MICROWAVE POWER LEVEL SET.
5. CONVECTION TEMPERATURE SELECTED.
6. STRAT BUTTON PRESSED.

NOTE: "★" indicates components with potentials above 250V

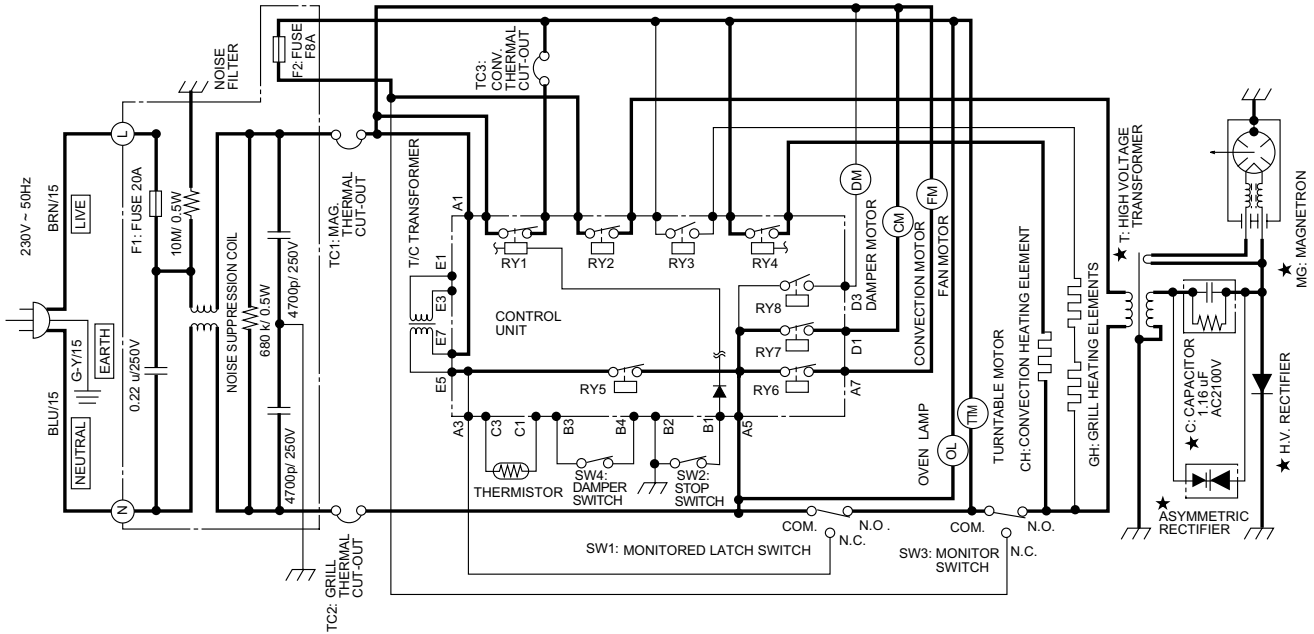

Figure O-5(a) Oven Schematic-Dual cooking Condition (Microwave and Convection)

SCHEMATIC

NOTE: CONDITION OF OVEN

1. DOOR CLOSED.
2. DUAL 2 MODE PAD TSET.
3. COOKING TIMESET.
4. MICROWAVE POWER LEVEL SET.
5. STRAT BUTTON PRESSED.

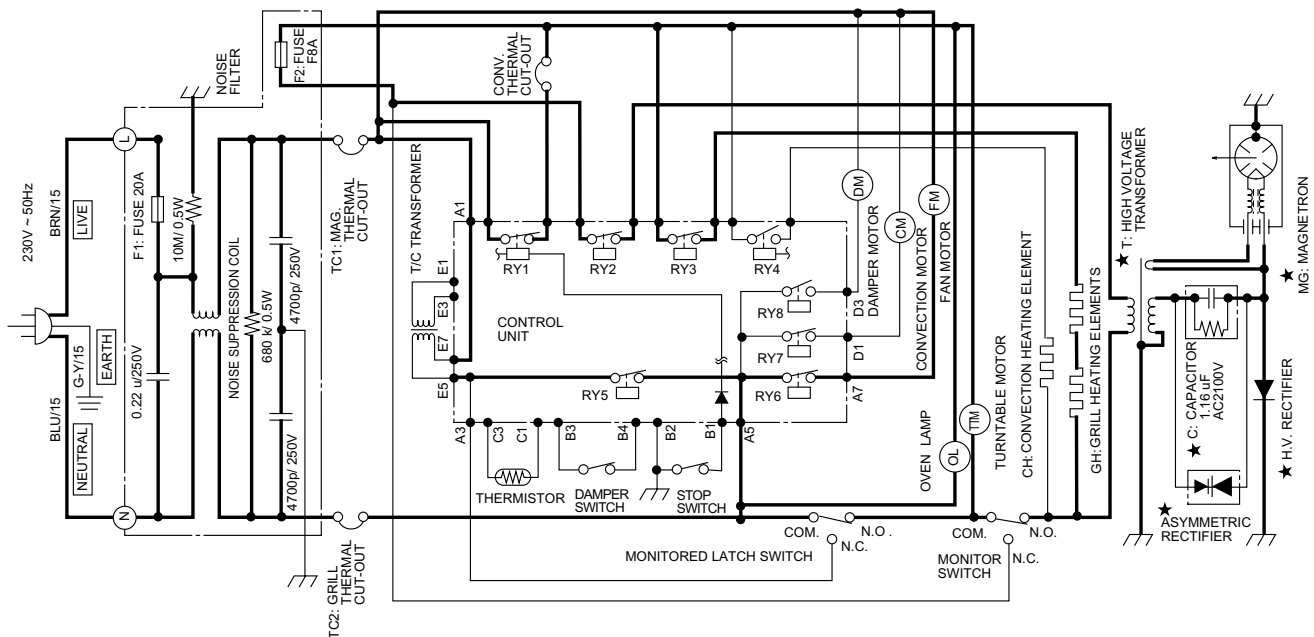

Figure O-5(b) Oven Schematic-Dual cooking Condition (Microwave and Grill)

[2] Pictorial Diagram

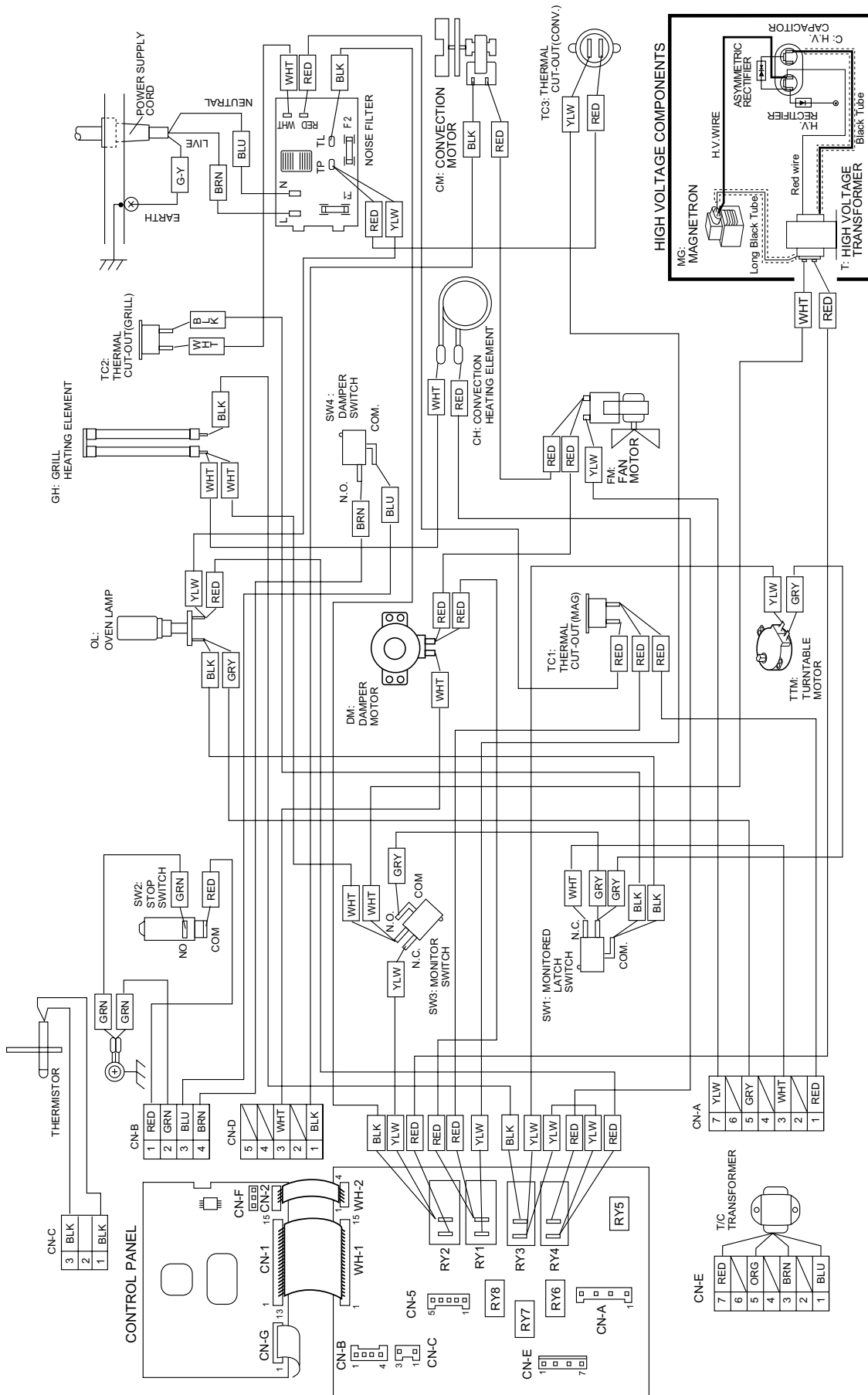
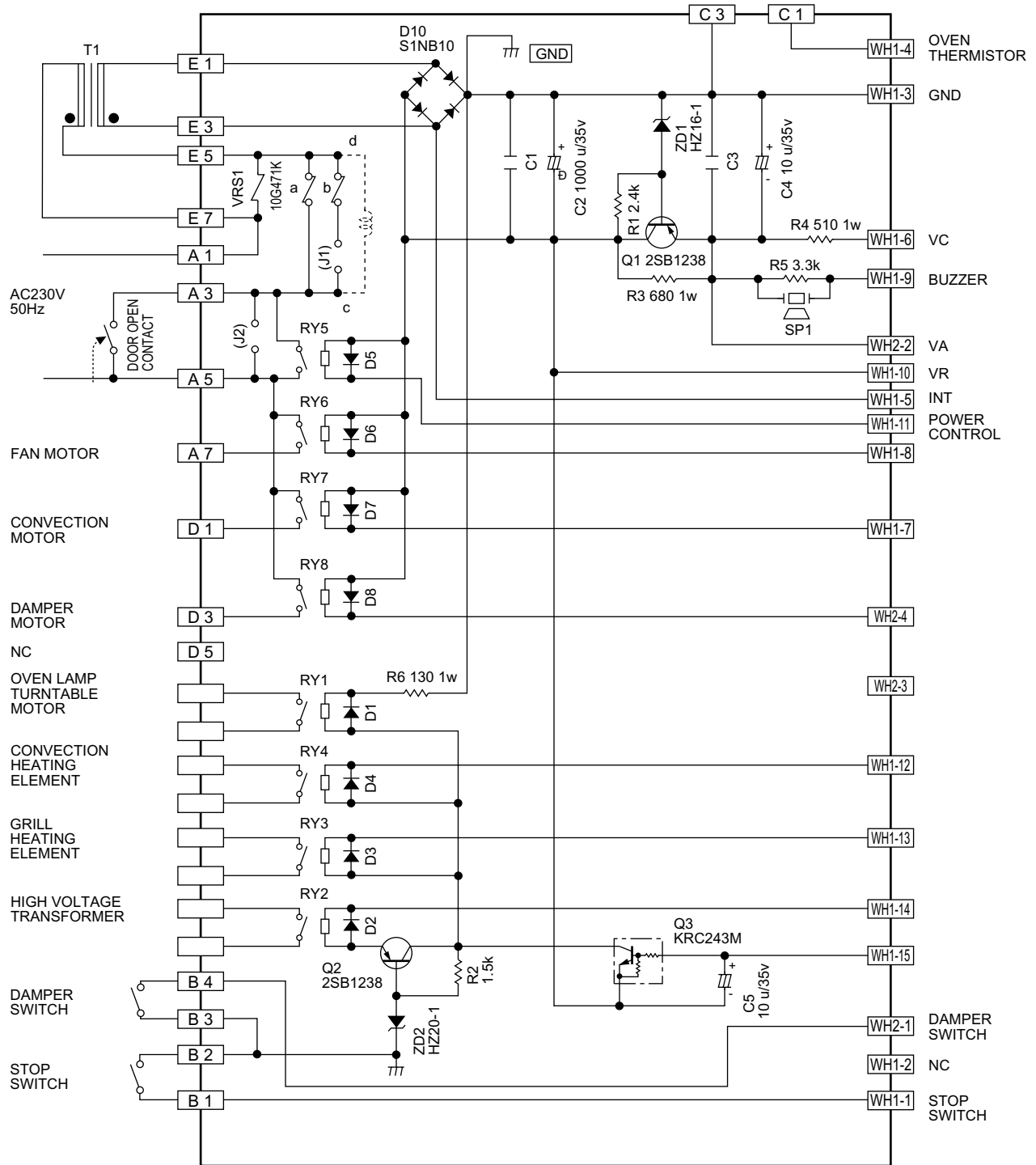

Figure S-1. Pictorial Diagram

[3] Power Unit Circuit



NOTE 1.

- : IF NOT SPECIFIED, 1/4W 5%
- | — : IF NOT SPECIFIED, 0.1 F / 50V
- ▶— : IF NOT SPECIFIED, 1SS270A

NOTE 2.

- WH1-n 15P WIRE HARNESS
- WH2-n 4P WIRE HARNESS

Figure S-2. Power Unit Circuit

[4] Control Unit Circuit

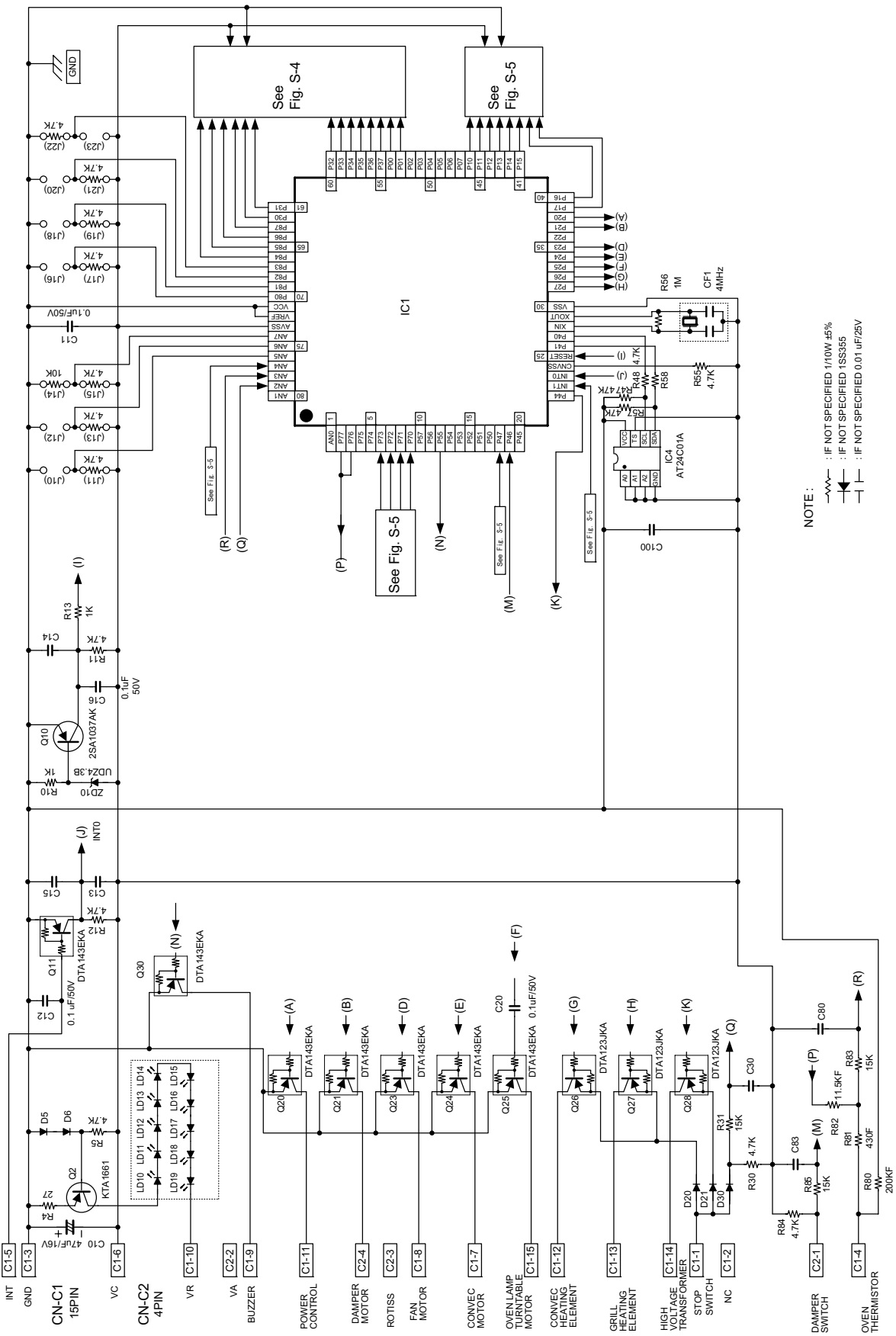

Figure S-3. CPU Unit Circuit

[6] Jog and Switch Unit Circuit

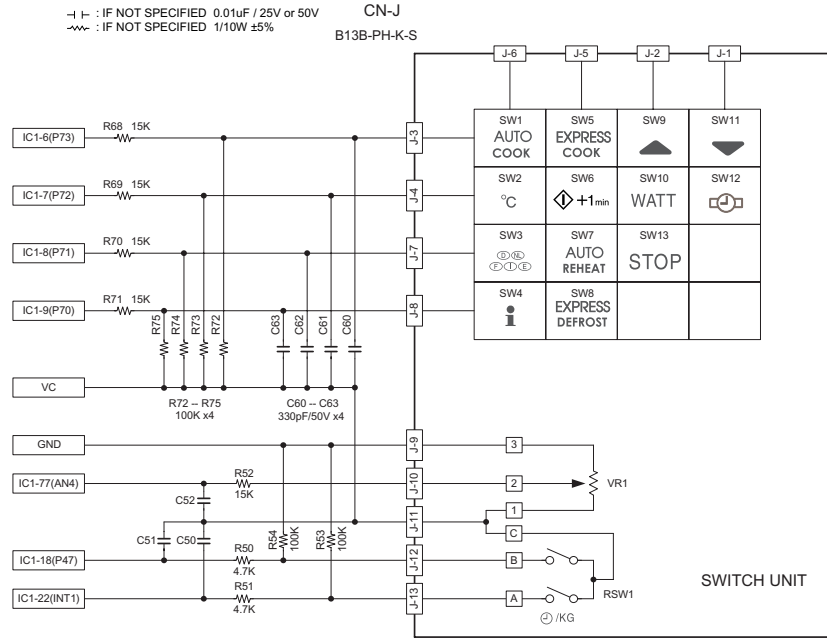

Figure S-5. Jog and Switch Unit Circuit

[7] Printed Wiring Board

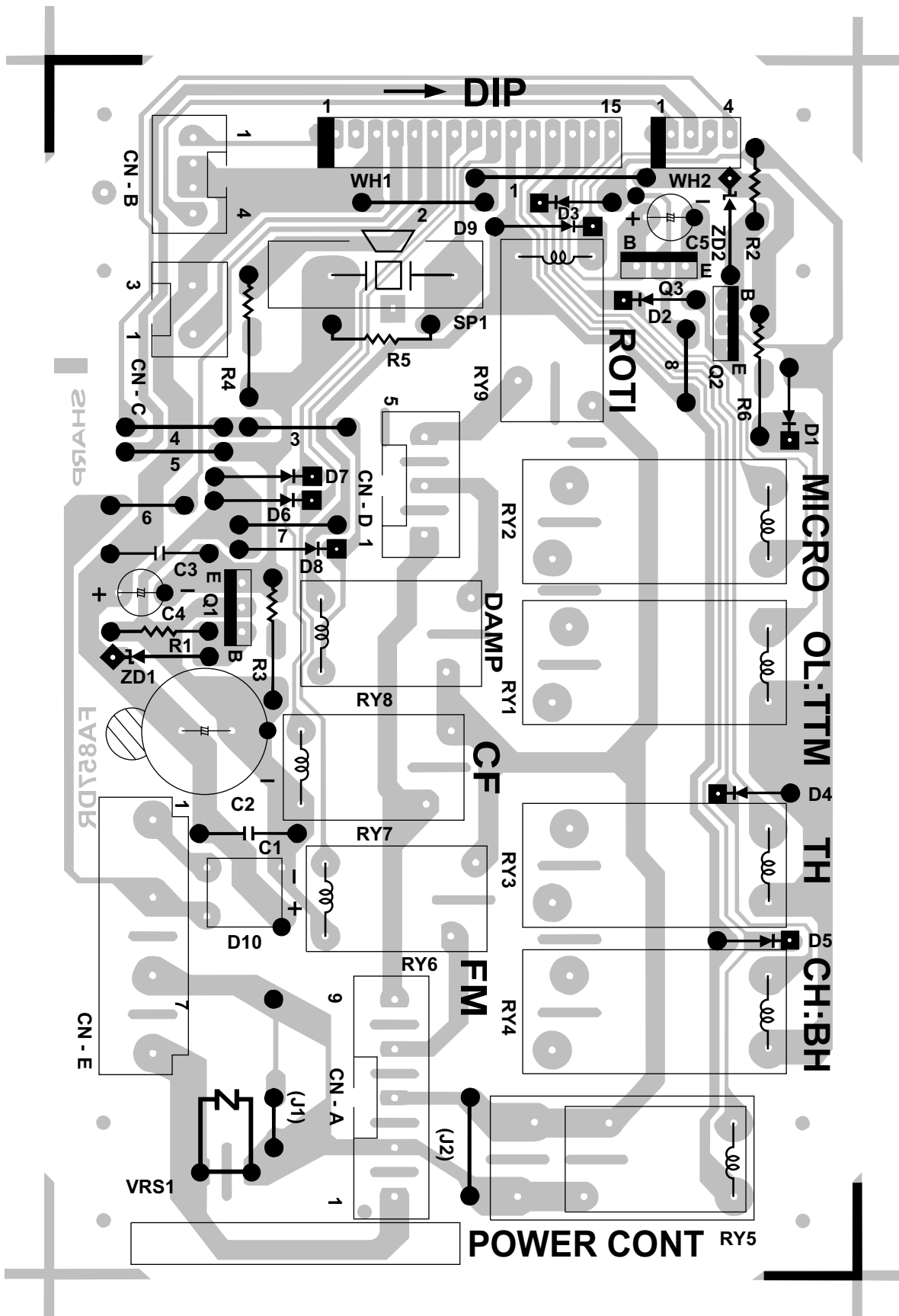

Figure S-6. Printed Wiring Board of Power Unit

[8] Printed Wiring of Board of Switch Unit

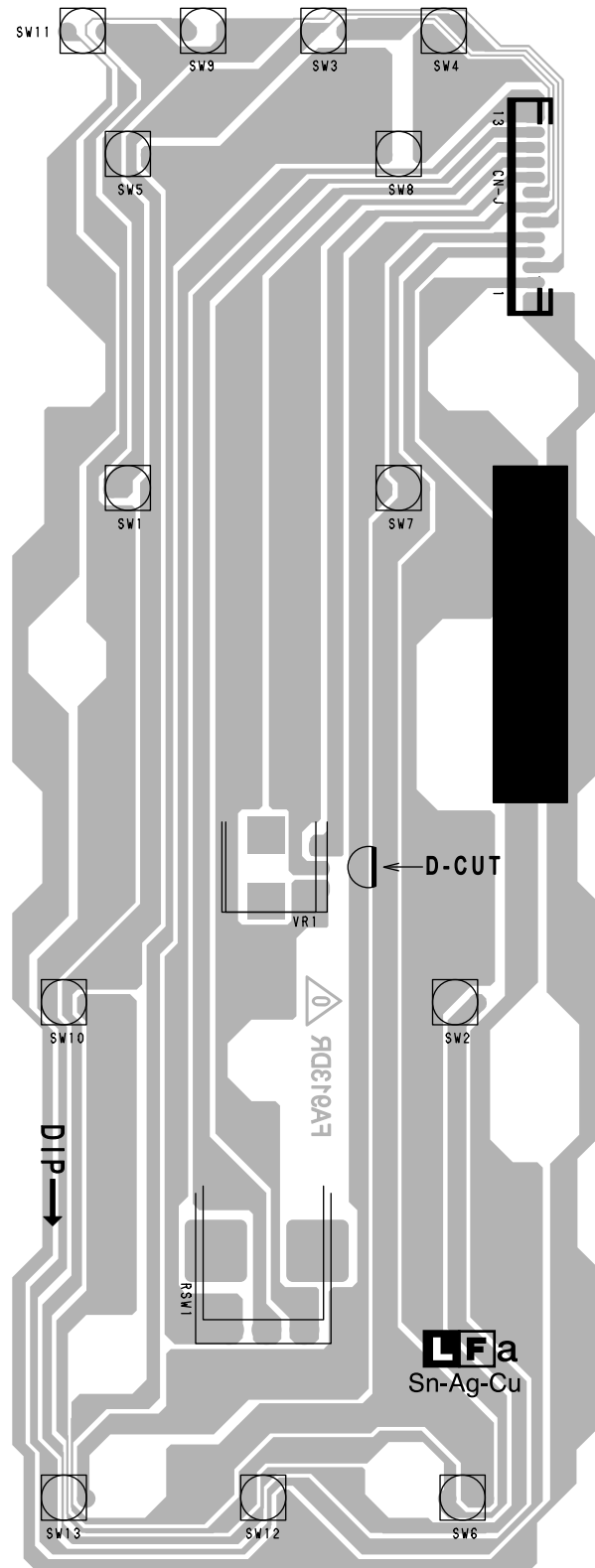

Figure S-7. Printed Wiring of Board of Switch Unit

SHARP PARTS LIST

MICROWAVE OVEN WITH GRILL AND CONVECTION

HOW TO ORDER REPLACEMENT PARTS

To have your order filled promptly and correctly, please furnish the following information.

1. MODEL NUMBER
2. REF. NO.
3. PART NO.
4. DESCRIPTION

MODELS R-939(BK) R-939(IN) R-939(W)

Parts marked "*" may cause undue microwave exposure.
Parts marked "▲" are used in voltage more than 250V.

CONTENTS

[1] OVEN PARTS

[2] CONTROL PANEL AND DOOR PARTS

■ INDEX

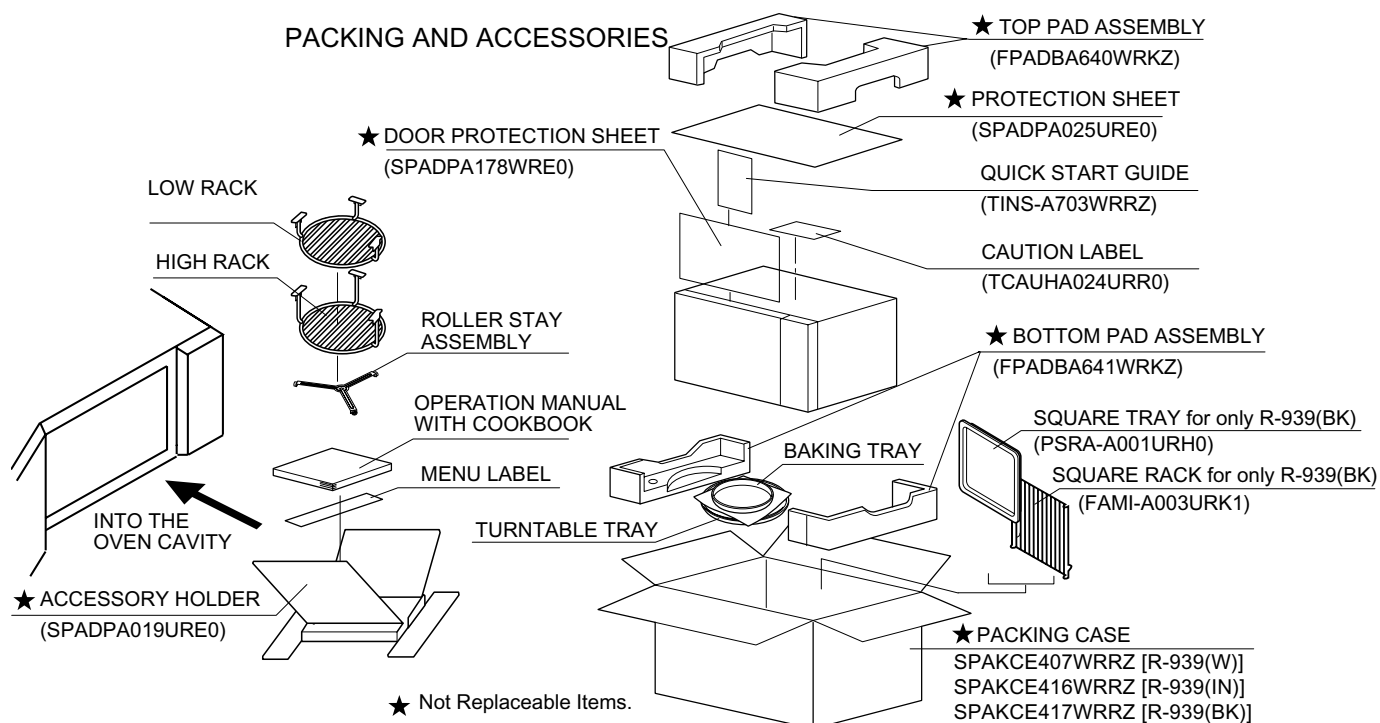

NO.	PARTS CODE	PRICE RANK	NEW MARK	PART RANK	DESCRIPTION
[1] OVEN PARTS					
ELECTRIC PARTS					
△	C	RC-QZA219WRE1	AS		High voltage capacitor
	CH	RHET-A269WRZ1	AY		Convection heating element
	CM	RMOTE415WRZ1	BB		Convection motor
	DM	RMOTDA269WRZ1	AP		Damper motor
	F1	QFS-BA012WRZZ	AG		Fuse 20A
	FM	RMOTE4002URE2	AV		Fan motor
	GH	RHET-A231WRZ1	AU		Grill heating element
△	MG	RV-MZA264WRE1	BG		Magnetron
	OL	RLMPTA066WRE1	AP		Oven lamp
	SW1	QSW-MA146WRZ1	AM		Monitored latch switch
	SW2	QSW-MA147WRZ1	AM		Stop switch
	SW3	QSW-MA146WRZ1	AM		Monitor switch
	SW4	QSW-MA147WRZ1	AM		Damper switch
△	T	RTRN-A016URE2	BL		High voltage transformer
	TC1	RTHM-A098WRE0	AK		Thermal cut-out 125°C (MG)
	TC2	RTHM-A109WRE0	AM		Thermal cut-out 170°C (GRILL)
	TC3	RTHM-A109WRE0	AM		Thermal cut-out 170°C (CONV.)
	TTM	RMOTDA267WRZ1	AP		Turntable motor
△	1-1	FH-DZA035WRE1	AS		High voltage rectifier assembly
	1-2	QACCV4004URE3	AT		Power supply cord
	1-3	FPWBF309WRE4	AT		Noise filter (F2: Fuse F8A)
	1-4	RTRN-A529WRE1	AW		TC transformer
	1-5	FH-HZA075WRE0	AS		Thermistor
CABINET PARTS					
	2-1	GCABDA005URP1	BC		Back plate
	2-2	GCABUB051WRPZ	BM		Outer case cabinet [R-939(W)]
	2-2	GCABUB052WRPZ	BN		Outer case cabinet [R-939(BK)] [R-939(IN)]
	2-3	GLEGPA057WRE2	AF		Foot
	2-4	GDAI-A003URP3	BA		Base plate
OVEN PARTS					
	4-1	PCUSUA312WRP0	AC		Cushion
	4-2	PCUSUA050URE0	AB		Cushion
	4-3	LANGFA002URP0	AL		Cavity support angle
*	4-4	DOVN-A024URK0	BU		Oven cavity
	4-5	MCAMPA001URF1	AF		Damper cam
	4-6	LANGTA009URP2	AG		Damper angle
	4-7	FFTA-A001URK0	AM		Damper assembly
	4-9	PDUC-A011URF1	AQ		Air intake duct
	4-10	PDUC-A014URP0	AH		Exhaust duct
	4-11	PSKR-A010URP0	AF		Partition plate B
	4-12	PDUC-A012URP0	AL		Air duct
	4-13	LANGQA017URP0	AF		Grill heater angle
	4-14	QTANNA001URP0	AC		Earth plate
	4-15	PREFHA001URP0	AS		Grill reflector
	4-16	LANG-A054WRP1	AK		Convection heater angle
	4-17	LANGQA308WRP1	AK		Convection motor angle
	4-18	NFANMA003URP0	AF		Cooling fan
	4-19	PDUC-A042URP0	AG		Convection duct
	4-20	PIPFA005UR10	AK		Pipe
	4-21	PSKR-A013URP0	AG		Air separate angle A
	4-22	PSKR-A014URP0	AF		Air separate angle B
	4-23	PSKR-A015URP0	AF		Air separate angle C
	4-24	PSKR-A016URP0	AF		Air separate angle D
	4-25	PSLDHA005URP0	AQ		Rear heat cover
	4-26	LANGQA018URP1	AM		Convection heater angle A
	4-27	PFPF-A002URE1	AL		Heat insulating material
	4-28	PSKR-A012URP0	AG		Air separate angle E
	4-29	PSKR-A308WRF1	AL		Rear barrier
	4-30	NFANMA004URP0	AG		Convection fan
*	4-31	PHOK-A002URF1	AT		Latch hook
	4-32	PDUC-A016URF1	AQ		Fan duct
	4-33	NFANJA038WRE0	AG		Fan blade
	4-34	GCOVHA002URP0	AG		Bottom heater cover
	4-35	LANGFA001URP1	AL		Chassis support
	4-36	NCPL-A040WRE2	AL		Coupling
	4-37	PCOVPA309WRE0	AF		Waveguide cover
	4-38	PFPF-A003URE2	AM		Heat insulating material
	4-39	PFILWA001URP0	AG		Lamp filter
	4-40	PPACGA101WRE0	AF		O-ring
	4-41	PSLDHA002URP3	AS		Heater cover right
	4-42	PSPAGA001WRE0	AB		Vibration proof cushion
	4-43	LBNDKA111WRP1	AG		Capacitor holder
MISCELLANEOUS					
	6-1	FROLPA060WRK0	AW		Roller stay
	6-2	NTNT-A040WRE0	AZ		Turntable tray
	6-10	LHLDKA008WRF1	AF		P-clip
SCREWS, NUTS AND WASHERS					
	7-1	XHPS740P08K00	AB		Screw: 4mm x 8mm
	7-2	LX-EZA042WRE0	AB		Special screw
	7-3	XCBBWW30P06000	AA		Screw: 3mm x 6mm
	7-4	XNEUW40-32000	AA		Nut: 4mm x 3.2mm
	7-5	XRES740-06000	AB		Ring

NO.	PARTS CODE	PRICE RANK	NEW MARK	PART RANK	DESCRIPTION
[1] OVEN PARTS					
7-6	XWSUW40-10000	AA			Washer: 4mm x 1.0mm
7-7	XEPS740P25000	AB			Screw: 4mm x 25mm
7-8	XHPS730P06000	AB			Screw : 3mm x 6mm
7-9	XJPS740P10X00	AB			Screw: 4mm x 10mm
7-10	XHPS740P06000	AB			Screw: 4mm x 6mm
7-11	XOTWW40P10000	AA			Screw : 4mm x 10mm
7-12	XPWW30P05K00	AA			Screw: 3mm x 5mm
7-13	XHTWW40P08000	AC			Screw: 4mm x 8mm
7-14	XJBS730P16000	AC			Screw:3mm x 16mm
7-15	XHTS740P08RV0	AG			Screw: 4mm x 8mm
7-16	LX-CZA001URE0	AC			Special screw
7-17	XOTS740P10000	AB			Screw: 4mm x 10mm

[2] CONTROL PANEL AND DOOR PARTS

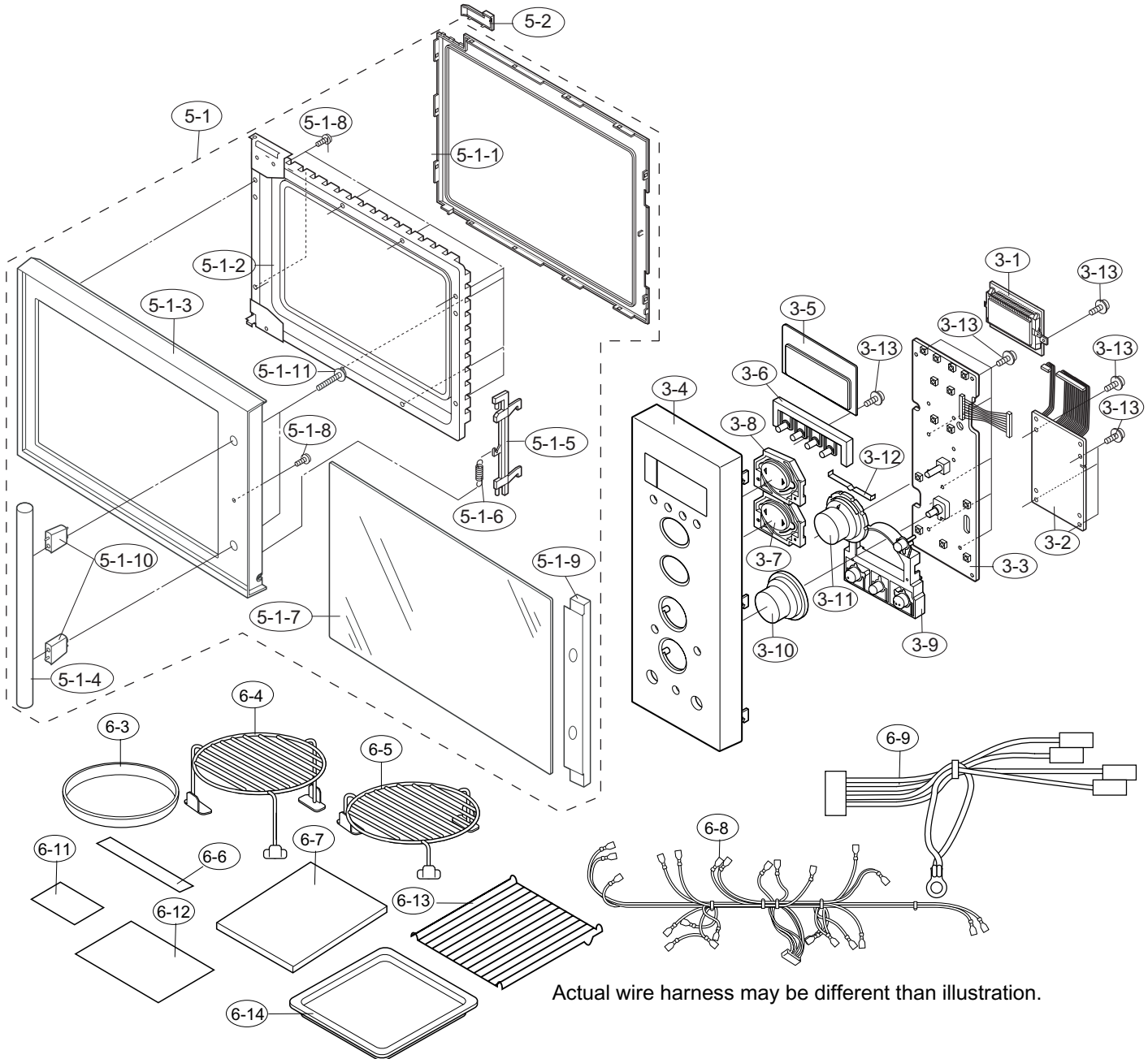

NO.	PARTS CODE	PRICE RANK	NEW MARK	PART RANK	DESCRIPTION
[2] CONTROL PANEL AND DOOR PARTS					
CONTROL PANEL PARTS					
3-1	DPWB-A406DRKZ	BR			CPU unit
3-2	DPWBF A226URK0	BQ			Power unit
3-3	DPWB-A411DRKZ	BC			Switch unit
3-4	HPNLCC006WRRZ	AV			Control panel [R-939(W)]
3-4	HPNLCC004WRRZ	AV			Control panel [R-939(BK)]
3-4	HPNLCC003WRRZ	AX			Control panel [R-939(IN)]
3-5	GMADIA163WRRZ	AL			Display window
3-6	JBTN-B367WRFZ	AG			Key button A [R-939(W)]
3-6	JBTN-B371WRTZ	AG			Key button A [R-939(BK)] [R-939(IN)]
3-7	JBTN-B368WRRZ	AG			Key button B [R-939(W)]
3-7	JBTN-B372WRRZ	AG			Key button B [R-939(BK)] [R-939(IN)]
3-8	JBTN-B369WRRZ	AG			Key button C [R-939(W)]
3-8	JBTN-B373WRRZ	AG			Key button C [R-939(BK)] [R-939(IN)]
3-9	JBTN-B370WRFZ	AG			Clear button [R-939(W)]
3-9	JBTN-B374WRTZ	AH			Clear button [R-939(BK)] [R-939(IN)]
3-10	JKNBKA766WRFZ	AG			Timer knob [R-939(W)]
3-10	JKNBKA769WRTZ	AG			Timer knob [R-939(BK)] [R-939(IN)]
3-11	JKNBKA767WRFZ	AG			Vari knob [R-939(W)]
3-11	JKNBKA770WRTZ	AG			Vari knob [R-939(BK)] [R-939(IN)]
3-12	MSPR-A006WREZ	AF			Switch spring
3-13	XEPS730P10X00	AA			Screw : 3mm x 10mm
DOOR PARTS					
* 5-1	CDORFB049WRKZ	BX			Door panel assembly [R-939(W)]
* 5-1	CDORFB051WRKZ	BV			Door panel assembly [R-939(BK)]
* 5-1	CDORFA050WRKZ	BV			Door panel assembly [R-939(IN)]
* 5-1-1	GCOVHA024URF0	AT			Choke cover
* 5-1-2	DDORFB260WRKZ	BF			Door panel
* 5-1-3	GWAKPB045WRFZ	AT			Door frame [R-939(W)]
* 5-1-3	GWAKPB048WRFZ	AT			Door frame [R-939(BK)]
* 5-1-3	GWAKPA046WRTZ	BD			Door frame [R-939(IN)]
* 5-1-4	JHNDPA259WREZ	AY			Door handle [R-939(W)]
* 5-1-4	JHNDPA264WREZ	BA			Door handle [R-939(BK)] [R-939(IN)]
* 5-1-5	LSTPPA017URF0	AK			Latch head
* 5-1-6	MSPRTA197WREZ	AF			Latch spring
* 5-1-7	PGLSPA668WREZ	AX			Front door glass [R-939(W)]
* 5-1-7	PGLSPA670WREZ	BA			Front door glass [R-939(BK)] [R-939(IN)]
* 5-1-8	XEPS730P06000	AC			Screw : 3mm x 6mm
* 5-1-9	JHNDPA260WRFZ	AH			Handle cover [R-939(W)]
* 5-1-9	JHNDPA263WRFZ	AN			Handle cover [R-939(BK)] [R-939(IN)]
* 5-1-10	JHNDPA261WRFZ	AG			Handle base [R-939(W)]
* 5-1-10	JHNDPA262WRFZ	AR			Handle base [R-939(BK)] [R-939(IN)]
* 5-1-11	XBTS740P44XS0	AC			Screw : 4mm x 44mm
* 5-2	LSTPPA018URF0	BB			Door stopper
MISCELLANEOUS					
6-3	PSRA-A025WRP1	AY			Baking tray
6-4	FAMi-A001URK1	AT			High rack
6-5	FAMi-A002URK1	AT			Low rack
6-6	TLABMB127WRRZ	AL			Menu label
6-7	TCADCA896WRRZ	AP			Operation Manual with Cook book
6-8	FW-VZA104URE2	BD			Main harness
6-9	FW-VZA074URE4	AN			Stop switch harness
6-11	TCAUHA024URR0	AE			Caution label [R-939(BK)] [R-939(IN)]
6-12	TINS-A703WRRZ	AM			Quick start guide
6-13	FAMi-A003URK1	AW			Square rack [R-939(BK)]
6-14	PSRA-A001URH0	AZ			Square tray [R-939(BK)]

INDEX

PARTS CODE	No.	PRICE RANK	NEW MARK	PART RANK
【 C 】				
CDORFA050WRKZ	2-5-1	BV		
CDORFB049WRKZ	2-5-1	BX		
CDORFB051WRKZ	2-5-1	BV		
【 D 】				
DDORFB260WRKZ	2-5-1-2	BF		
DOVN-A024URK0	1-4-4	BU		
DPWB-A406DRKZ	2-3-1	BR		
DPWB-A411DRKZ	2-3-3	BC		
DPWBFA226URK0	2-3-2	BQ		
【 F 】				
FAMi-A001URK1	2-6-4	AT		
FAMi-A002URK1	2-6-5	AT		
FAMi-A003URK1	2-6-1-3	AW		
FFTA-A001URK0	1-4-7	AM		
FH-DZA035WRE1	1-1-1	AS		
FH-HZA075WRE0	1-1-5	AS		
FPWBFA309WRE4	1-1-3	AT		
FROLPA060WRK0	1-6-1	AW		
FW-VZA074URE4	2-6-9	AN		
FW-VZA104URE2	2-6-8	BD		
【 G 】				
GCABDA005URP1	1-2-1	BC		
GCABUB051WRPZ	1-2-2	BM		
GCABUB052WRPZ	1-2-2	BN		
GCOVHA002URP0	1-4-3-4	AG		
GCOVHA024URF0	2-5-1-1	AT		
GDAi-A003URP3	1-2-4	BA		
GLEGPA057WRE2	1-2-3	AF		
GMADiA163WRRZ	2-3-5	AL		
GWAKPA046WRTZ	2-5-1-3	BD		
GWAKPB045WRFZ	2-5-1-3	AT		
GWAKPB048WRFZ	2-5-1-3	AT		
【 H 】				
HPNLCC003WRRZ	2-3-4	AX		
HPNLCC004WRRZ	2-3-4	AV		
HPNLCC006WRRZ	2-3-4	AV		
【 J 】				
JBTN-B367WRFZ	2-3-6	AG		
JBTN-B368WRRZ	2-3-7	AG		
JBTN-B369WRRZ	2-3-8	AG		
JBTN-B370WRFZ	2-3-9	AG		
JBTN-B371WRTZ	2-3-6	AG		
JBTN-B372WRRZ	2-3-7	AG		
JBTN-B373WRRZ	2-3-8	AG		
JBTN-B374WRTZ	2-3-9	AH		
JHNDPA259WREZ	2-5-1-4	AY		
JHNDPA260WRFZ	2-5-1-9	AH		
JHNDPA261WRFZ	2-5-1-10	AG		
JHNDPA262WRFZ	2-5-1-10	AR		
JHNDPA263WRFZ	2-5-1-9	AN		
JHNDPA264WREZ	2-5-1-4	BA		
JKNBKA766WRFZ	2-3-10	AG		
JKNBKA767WRFZ	2-3-11	AG		
JKNBKA769WRTZ	2-3-10	AG		
JKNBKA770WRTZ	2-3-11	AG		
【 L 】				
LANG-A054WRP1	1-4-16	AK		
LANGFA001URP1	1-4-35	AL		
LANGFA002URP0	1-4-3	AL		
LANGQA017URP0	1-4-13	AF		
LANGQA018URP1	1-4-26	AM		
LANGQA308WRP1	1-4-17	AK		
LANGTA009URP2	1-4-6	AG		
LBNDKA111WRP1	1-4-43	AG		
LHLDKA008WRF1	1-6-10	AF		
LSTPPA017URF0	2-5-1-5	AK		
LSTPPA018URF0	2-5-2	BB		
LX-CZA001URE0	1-7-16	AC		
LX-EZA042WRE0	1-7-2	AB		
【 M 】				
MCAMPA001URF1	1-4-5	AF		
MSPR-A006WREZ	2-3-12	AF		
MSPRTA197WREZ	2-5-1-6	AF		
【 N 】				
NCPL-A040WRE2	1-4-36	AL		
NFANJA038WRE0	1-4-33	AG		
NFANMA003URP0	1-4-18	AF		
NFANMA004URP0	1-4-30	AG		

PARTS CODE	No.	PRICE RANK	NEW MARK	PART RANK
NTNT-A040WRE0	1-6-2	AZ		
【 P 】				
PCOVPA309WRE0	1-4-37	AF		
PCUSUA050URE0	1-4-2	AB		
PCUSUA312WRP0	1-4-1	AC		
PDUC-A011URF1	1-4-9	AQ		
PDUC-A012URP0	1-4-12	AL		
PDUC-A014URP0	1-4-10	AH		
PDUC-A016URF1	1-4-32	AQ		
PDUC-A042URP0	1-4-19	AG		
PFI LWA001URP0	1-4-39	AG		
PFPF-A002URE1	1-4-27	AL		
PFPF-A003URE2	1-4-38	AM		
PGLSPA668WREZ	2-5-1-7	AX		
PGLSPA670WREZ	2-5-1-7	BA		
PHOK-A002URF1	1-4-31	AT		
PPACGA101WRE0	1-4-40	AF		
PI PFA005UR10	1-4-20	AK		
PREFHA001URP0	1-4-15	AS		
PSKR-A010URP0	1-4-11	AF		
PSKR-A012URP0	1-4-28	AG		
PSKR-A013URP0	1-4-21	AG		
PSKR-A014URP0	1-4-22	AF		
PSKR-A015URP0	1-4-23	AF		
PSKR-A016URP0	1-4-24	AF		
PSKR-A308WRF1	1-4-29	AL		
PSLDHA002URP3	1-4-41	AS		
PSLDHA005URP0	1-4-25	AQ		
PSPAGA001WRE0	1-4-42	AB		
PSRA-A001URH0	2-6-14	AZ		
PSRA-A025WRP1	2-6-3	AY		
【 Q 】				
QACCVA004URE3	1-1-2	AT		
QFS-BA012WRZZ	1-F1	AG		
QSW-MA146WRZ1	1-SW1	AM		
"	1-SW3	AM		
QSW-MA147WRZ1	1-SW2	AM		
"	1-SW4	AM		
QTANNA001URP0	1-4-14	AC		
【 R 】				
RC-QZA219WRE1	1-C	AS		
RHET-A231WRZ1	1-GH	AU		
RHET-A269WRZ1	1-CH	AY		
RLMPTA066WRE1	1-OL	AP		
RMOTDA267WRZ1	1-TTM	AP		
RMOTDA269WRZ1	1-DM	AP		
RMOTEA002URE2	1-FM	AV		
RMOTEA415WRZ1	1-CM	BB		
RTHM-A098WRE0	1-TC1	AK		
RTHM-A109WRE0	1-TC2	AM		
"	1-TC3	AM		
RTRN-A016URE2	1-T	BL		
RTRN-A529WRE1	1-1-4	AW		
RV-MZA264WRE1	1-MG	BG		
【 T 】				
TCADCA896WRRZ	2-6-7	AP		
TCAUHA024URR0	2-6-11	AE		
TINS-A703WRRZ	2-6-12	AM		
TLABMB127WRRZ	2-6-6	AL		
【 X 】				
XBPWW30P05K00	1-7-12	AA		
XBTS740P44XS0	2-5-1-11	AC		
XCBWW30P06000	1-7-3	AA		
XEBS730P06000	2-5-1-8	AC		
XEPS730P10X00	2-3-13	AA		
XEPS740P25000	1-7-7	AB		
XHPS730P06000	1-7-8	AB		
XHPS740P06000	1-7-10	AB		
XHPS740P08K00	1-7-1	AB		
XHTS740P08RV0	1-7-15	AG		
XHTWW40P08000	1-7-13	AC		
XJBS730P16000	1-7-14	AC		
XJPS740P10X00	1-7-9	AB		
XNEUW40-32000	1-7-4	AA		
XOTS740P10000	1-7-17	AB		
XOTWW40P10000	1-7-11	AA		
XRES740-06000	1-7-5	AB		
XWSUW40-10000	1-7-6	AA		