

JBL

®

DIGITAL
SIMPLY CINEMA

DSC 1000

SERVICE MANUAL

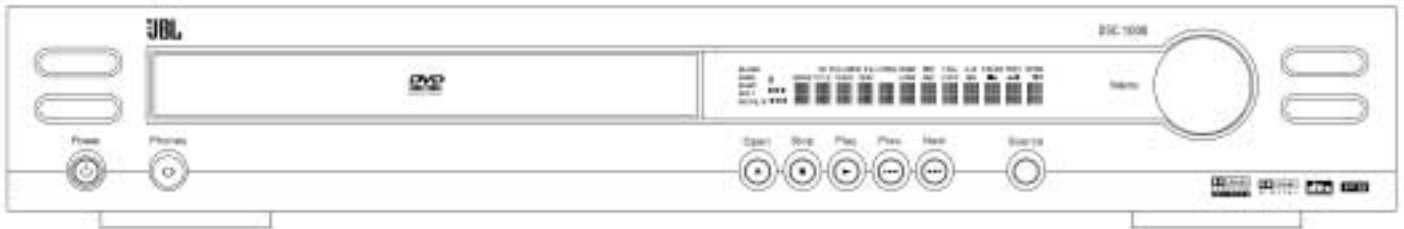

DSC 1000 CONTROLLER SPECIFICATIONS

DVD player

Pickup:	Semiconductor laser, wavelength 650nm
Signal system:	NTSC / PAL
Video signal horizontal resolution:	More than 480 lines (DVD)
Video signal-to-noise ratio:	More than 60 dB (DVD)
Audio frequency response: (Stereo)	DVD (PCM): 20Hz ~ 22kHz (+/- 1.0dB) CD (PCM): 20Hz ~ 20kHz (+/- 1.0dB)
Audio signal-to-noise ratio:	More than 80 dB (PCM)
Total harmonic distortion::	Less than 0.01% (PCM)
Dynamic range:	DVD (PCM): More than 85 dB (EIAJ, 2kHz) CD: More than 85 dB (EIAJ)

FM Tuner

System:	PLL quartz-locked digital synthesizer system
Tuning range:	87.50 ~ 108.00 MHz
Antenna terminals:	75 ohms, unbalanced
Intermediate frequency:	10.7 MHz

Video Outputs

Component Video Output:	Y: 1 V _{p-p} /75 Ohms, sync negative polarity Cr: 0.7 V _{p-p} /75 Ohms Cb: 0.7 V _{p-p} /75 Ohms
CVBS Video:	1 V _{p-p} 75 ohms
S-video:	Y: 1 V _{p-p} 75 ohms C: PAL 0.3 V _{p-p} 75 ohms / NTSC 0.286 V _{p-p} 75 ohms

Audio line Outputs

Audio L/R:	1 V _{rms} , 1 kilohms
------------	--------------------------------

General

Power requirements:	AC 230 V, 50 Hz
Power consumption:	20 W
Dimensions (WxHxD):	431 x 75 x 352 mm, 17" x 3" x 14"
Weight:	8.5 kg, 18.7 lb.

* Designs and specifications are subject to change without notice.

JBL continually strives to improve its products by introducing design refinements into existing models without notice. For this reason, the DSC 1000 systems may differ in some respects from the published specifications and descriptions, but will always equal or exceed the original specifications unless otherwise stated.

CONSUMERS SHOULD NOTE THAT NOT ALL HIGH DEFINITION TELEVISION SETS ARE FULLY COMPATIBLE WITH THIS PRODUCT AND MAY CAUSE ARTIFACTS TO BE DISPLAYED IN THE PICTURE. IN CASE OF 525 OR 625 PROGRESSIVE SCAN PICTURE PROBLEMS, IT IS RECOMMENDED THAT THE USER SWITCH THE CONNECTION TO THE 'STANDARD DEFINITION' OUTPUT. IF THERE ARE QUESTIONS REGARDING OUR TV SET COMPATIBILITY WITH THIS MODEL 525p AND 625p DVD PLAYER, PLEASE CONTACT OUR CUSTOMER SERVICE CENTER.

SERVICING PRECAUTIONS

NOTES REGARDING HANDLING OF THE PICK-UP

1. Notes for transport and storage

- 1) The pick-up should always be left in its conductive bag until immediately prior to use.
- 2) The pick-up should never be subjected to external pressure or impact.

Storage in conductive bag

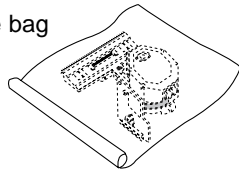

Drop impact

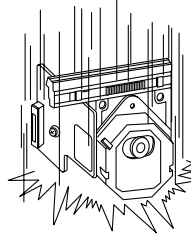

2. Repair notes

- 1) The pick-up incorporates a strong magnet, and so should never be brought close to magnetic materials.
- 2) The pick-up should always be handled correctly and carefully, taking care to avoid external pressure and impact. If it is subjected to strong pressure or impact, the result may be an operational malfunction and/or damage to the printed-circuit board.
- 3) Each and every pick-up is already individually adjusted to a high degree of precision, and for that reason the adjustment point and installation screws should absolutely never be touched.
- 4) Laser beams may damage the eyes!
Absolutely never permit laser beams to enter the eyes!
Also NEVER switch ON the power to the laser output part (lens, etc.) of the pick-up if it is damaged.

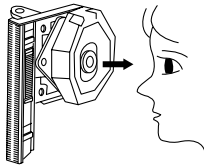

NEVER look directly at the laser beam, and don't let contact fingers or other exposed skin.

5) Cleaning the lens surface

If there is dust on the lens surface, the dust should be cleaned away by using an air bush (such as used for camera lens). The lens is held by a delicate spring. When cleaning the lens surface, therefore, a cotton swab should be used, taking care not to distort this.

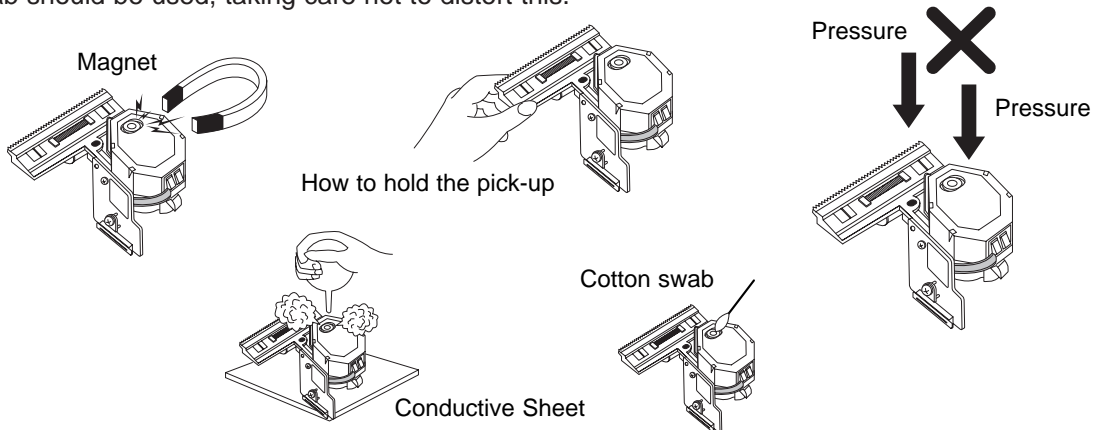

6) Never attempt to disassemble the pick-up.

Spring by excess pressure. If the lens is extremely dirty, apply isopropyl alcohol to the cotton swab. (Do not use any other liquid cleaners, because they will damage the lens.) Take care not to use too much of this alcohol on the swab, and do not allow the alcohol to get inside the pick-up.

NOTES REGARDING COMPACT DISC PLAYER REPAIRS

1. Preparations

- 1) Compact disc players incorporate a great many ICs as well as the pick-up (laser diode). These components are sensitive to, and easily affected by, static electricity. If such static electricity is high voltage, components can be damaged, and for that reason components should be handled with care.
- 2) The pick-up is composed of many optical components and other high-precision components. Care must be taken, therefore, to avoid repair or storage where the temperature of humidity is high, where strong magnetism is present, or where there is excessive dust.

2. Notes for repair

- 1) Before replacing a component part, first disconnect the power supply lead wire from the unit
- 2) All equipment, measuring instruments and tools must be grounded.
- 3) The workbench should be covered with a conductive sheet and grounded.
When removing the laser pick-up from its conductive bag, do not place the pick-up on the bag. (This is because there is the possibility of damage by static electricity.)
- 4) To prevent AC leakage, the metal part of the soldering iron should be grounded.
- 5) Workers should be grounded by an armband (1M Ω)
- 6) Care should be taken not to permit the laser pick-up to come in contact with clothing, in order to prevent static electricity changes in the clothing to escape from the armband.
- 7) The laser beam from the pick-up should NEVER be directly facing the eyes or bare skin.

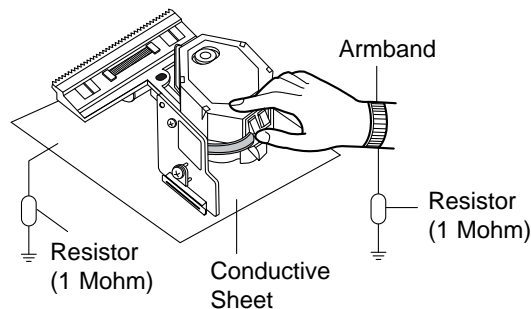

ESD PRECAUTIONS

Electrostatically Sensitive Devices (ESD)

Some semiconductor (solid state) devices can be damaged easily by static electricity. Such components commonly are called Electrostatically Sensitive Devices (ESD). Examples of typical ESD devices are integrated circuits and some field-effect transistors and semiconductor chip components. The following techniques should be used to help reduce the incidence of component damage caused by static electricity.

1. Immediately before handling any semiconductor component or semiconductor-equipped assembly, drain off any electrostatic charge on your body by touching a known earth ground. Alternatively, obtain and wear a commercially available discharging wrist strap device, which should be removed for potential shock reasons prior to applying power to the unit under test.
2. After removing an electrical assembly equipped with ESD devices, place the assembly on a conductive surface such as aluminum foil, to prevent electrostatic charge buildup or exposure of the assembly.
3. Use only a grounded-tip soldering iron to solder or unsolder ESD devices.
4. Use only an anti-static solder removal device. Some solder removal devices not classified as "anti-static" can generate electrical charges sufficient to damage ESD devices.
5. Do not use freon-propelled chemicals. These can generate electrical charges sufficient to damage ESD devices.
6. Do not remove a replacement ESD device from its protective package until immediately before you are ready to install it. (Most replacement ESD devices are packaged with leads electrically shorted together by conductive foam, aluminum foil or comparable conductive materials).
7. Immediately before removing the protective material from the leads of a replacement ESD device, touch the protective material to the chassis or circuit assembly into which the device will be installed.

CAUTION : BE SURE NO POWER IS APPLIED TO THE CHASSIS OR CIRCUIT, AND OBSERVE ALL OTHER SAFETY PRECAUTIONS.

8. Minimize bodily motions when handling unpackaged replacement ESD devices. (Otherwise harmless motion such as the brushing together of your clothes fabric or the lifting of your foot from a carpeted floor can generate static electricity sufficient to damage an ESD device).

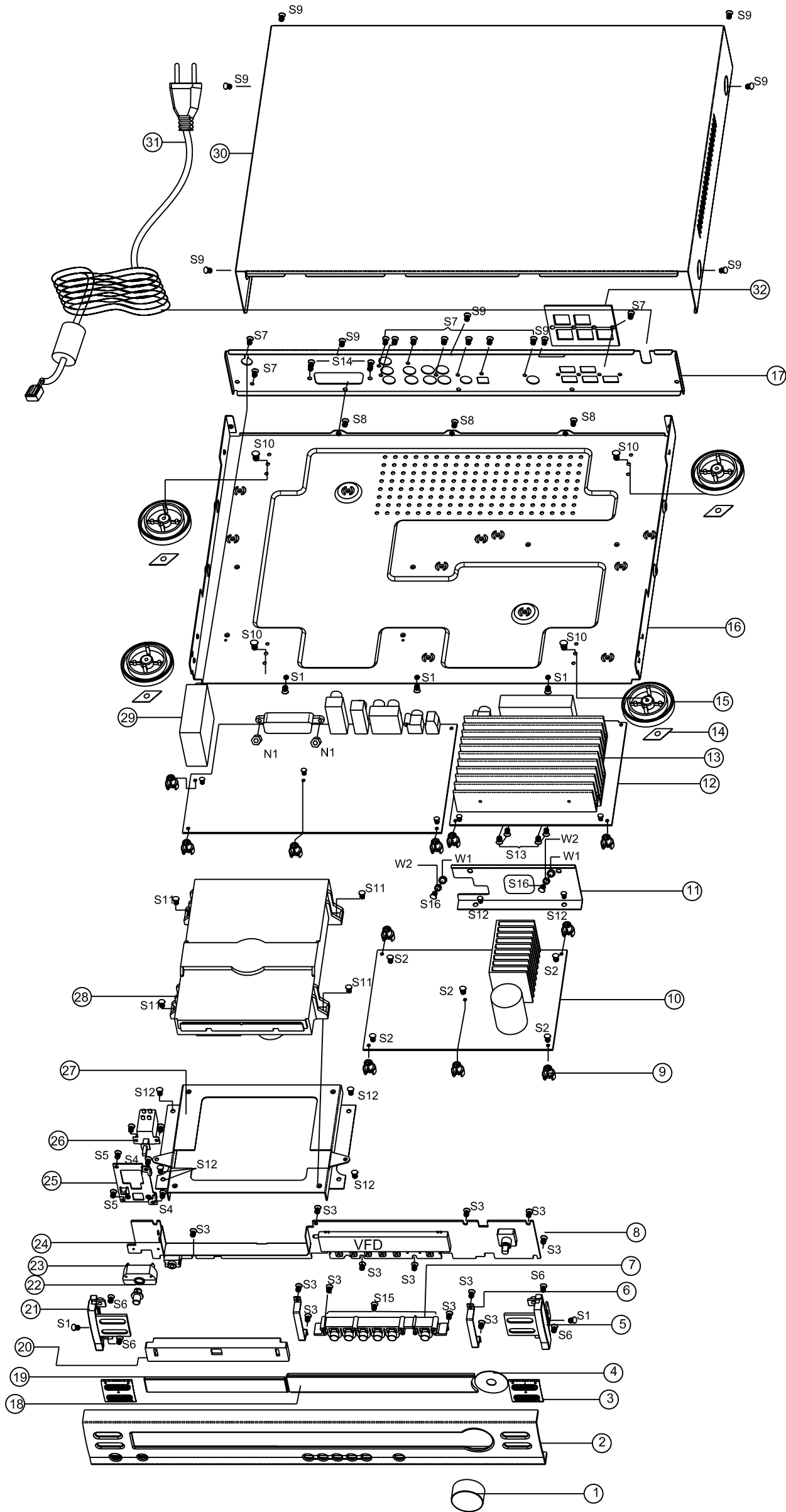

NO.	PART NO.	Q'TY	DESCRIPTION
1	331-3000RE12-0000	1	Volume knob
2	385-VD31ZPA2-5000	1	Aluminium alloy front panel
3	332-7DSCPT11-0000	2	Net cover on front panel
4	331-90033702-Q200	1	Shade for volume knob
5	330-ADSCRE07-0000	1	Right baffle
6	332-3DSCPT06-0000	2	Len support
7	331-1000RE01-8000	1	Button
8	300-D001242C-0002	1	Front panel board
9	332-20007008-0000	11	PCB plastic frame
10	300-A001356C-0001	1	Power supplier board
11	332-3DSCPT07-0000	1	Heat-sink support
12	300-O01241C-0002	1	Amplifier board
13	385-01459545-5200	1	Heat-sink
14	350-0DSC1000-0000	4	Pedestal underlay
15	331-4DSC1000-4000	4	Pedestal
16	380-B0DSC100-8000	1	Chassis
17	380-CDSC1000-0500	1	Back panel
18	331-8000RE05-8000	1	Len for VFD
19	331-8000RE04-8000	1	Len for tray door
20	330-2000RE03-8000	1	Disc tray door
21	330-ADSCRE06-0000	1	Left baffle
22	331-1000RE02-8000	1	Power button
23	331-5VD28016-7000	1	Power indicator lampshade
24	330-ADSCPT12-0000	1	Baffle for tray door
25	332-3DSCPT05-0000	1	Power button support
26	170-APS5EA07-0000	1	Power switch (20mm)
27	332-3DSCPT04-0000	1	Loader support
28	206-0000DV34-2202	1	LOADER
29	204-001E803A-0300	1	FM tuner model
30	380-ADSC1000-8500	1	Top cover
31	162-A0000350-0000	1	Power cord
32	600-000H0205-0020	1	Aluminium alloy plate for back panel
S1	381-00300611-2300	5	SCREW ST KBTTO M3×6
S2	381-00301314-1311	11	SCREW ST PWMTC M3×13
S3	381-00300651-2200	13	SCREW ST RTHO M 3×6
S4	381-00300611-2200	2	SCREW ST PTHO M3×6
S5	381-00300411-2200	2	SCREW ST PTHO M3×4
S6	381-00301211-2200	4	SCREW ST PTHO M3×12
S7	381-00300811-2200	13	SCREW ST PAHO M3×8
S8	381-00300614-1212	3	SCREW ST PWBTTTO M3×6
S9	381-00300614-1111	9	SCREW ST PWBTTNI M3×6
S10	381-00400851-2200	4	SCREW ST RTHO M 4×8
S11	381-00300814-1311	4	SCREW ST PWMTC M3×8
S12	381-00300614-1311	6	SCREW ST PWMTC M3×6
S13	381-00301211-1212	4	SCREW ST PWBTTTO M3×12
S14	381-00300851-1301	2	SCREW PMO M3×8
S15	381-02500611-2300	6	SCREW ST PAHC M2.5×6
S16	381-00300614-1312	2	SCREW ST PWBTTTC 3×8
W1	383-M03C0050-0008	6	WASHER PLAIN 3
W2	383-M3000000-0000	6	WASHER SPRING 3
N1	382-000000M3-1100	2	NUT M3

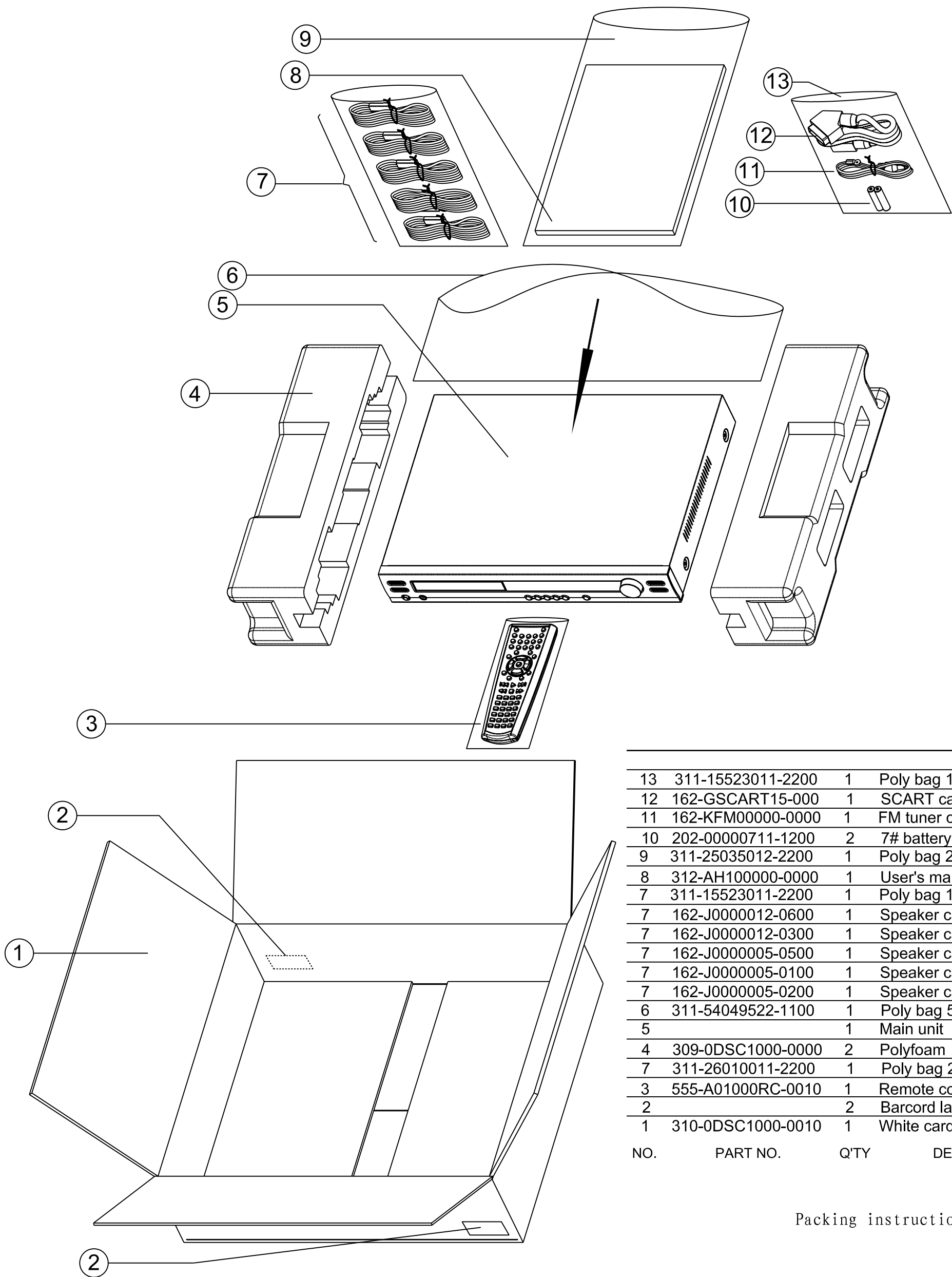

13	311-15523011-2200	1	Poly bag 155×230
12	162-GSCART15-000	1	SCART cable 1.5m
11	162-KFM00000-0000	1	FM tuner cable
10	202-00000711-1200	2	7# battery
9	311-25035012-2200	1	Poly bag 250×350
8	312-AH100000-0000	1	User's manual
7	311-15523011-2200	1	Poly bag 155×230
7	162-J0000012-0600	1	Speaker cable 12m blue jack
7	162-J0000012-0300	1	Speaker cable 12m grey jack
7	162-J0000005-0500	1	Speaker cable 5m green jack
7	162-J0000005-0100	1	Speaker cable 5m white jack
7	162-J0000005-0200	1	Speaker cable 5m rad jack
6	311-54049522-1100	1	Poly bag 540×495×T0.8
5		1	Main unit
4	309-0DSC1000-0000	2	Polyfoam
7	311-26010011-2200	1	Poly bag 260×100
3	555-A01000RC-0010	1	Remote control
2		2	Barcode label
1	310-0DSC1000-0010	1	White cardon
NO.	PART NO.	Q'TY	DESCRIPTION

DSC1000

Packing instruction

DSC1000 Component list

Item	Parts No.	Qty	SPECIFICATION	Remarks(English)
METAL PART				
1	380-B0DSC100-8000	1	Chassis	DSC1000-PT01
2	380-ADSC1000-8500	1	Top cover	DSC1000-PT02
3	380-CDSC1000-0500	1	Back panel	DSC1000-PT03
4	332-3DSCPT04-0000	1	Loader support	DSC1000-PT04
5	332-3DSCPT05-0000	1	Power button support	DSC1000-PT05
6	332-3DSCPT06-0000	2	Len support	DSC1000-PT06
7	332-3DSCPT07-0000	1	Heat-sink support	DSC1000-PT07
8	385-01459545-5200	1	Heat-sink	DSC1000-PT08, 145x95x45mm
9	385-00161235-5200	2	Heat-sink, for SMPS D17 D18	16X12X35mm
10	385-00501935-5200	1	Heat-sink, for SMPS Q16	50X19X35mm
11	385-VD31ZPA2-5000	1	Aluminium alloy front panel	DSC1000-PT09
12	332-7DSCPT11-0000	2	Net cover on front panel	DSC1000-PT11
13	330-ADSCPT12-0000	1	Baffle for tray door	DSC1000-PT12
14	600-000H0205-0020	1	Amplifier speaker output label	DSC1000-H02
15	385-00282810-0000	1	Heat-sink, for MainBoard U4	28x28x10mm
PLASTIC PART				
16	332-10MV7200-0000	2	Decorate lamp holder	MV7200
17	500-09130126-0000	1	Insulated underlay for AC cord	130x126mm
18	500-10202011-0010	1	Insulated underlay for SMPS	20x20x11mm
19	331-1000RE01-8000	1	Button	DSC1000-RE01
20	331-1000RE02-8000	1	Power button	DSC1000-RE02
21	330-2000RE03-8000	1	Disc tray door	DSC1000-RE03
22	331-8000RE04-8000	1	Len for tray door	DSC1000-RE04
23	331-8000RE05-8000	1	Len for VFD VFD	DSC1000-RE05
24	330-ADSCRE06-0000	1	Left baffle	DSC1000-RE06
25	330-ADSCRE07-0000	1	Right baffle	DSC1000-RE07
26	331-5VD28016-7000	1	Power indicator lampshade	DSC1000-RE08
27	331-3000RE12-0000	1	Volume knob	DSC1000-RE12
28	331-4DSC1000-4000	4	Pedestal	bronzing, size same as DVD 25, specify color
29	350-0DSC1000-0000	4	Pedestal underlay	same as DVD25
30	332-200SZ003-0200	1	IR receiver head frame	SZ003

DSC1000 Component list

31	350-00202006-0200	2	VFD soft pad VFD	20mm×20mm×6mm
32	331-7C035040-0010	2	Alumium fastener	cover pyrocondensation cannula F 3×40mm
33	500-70000000-0000	1	Plastic fastener	fasten the power cord
34	332-40000000-0000	6	Screw map	
35	500-02000000-0030	2	Lead nip	
36	500-01025015-0001	2	3M double glue 3M	25×15mm
37	332-20007008-0000	11	PCB plastic frame PCB	F 7×8.6mm
38	500-09002024-0000	1	Talc piece for SMPS Q6	F 20×24mm
39	350-00161101-2600	3	Diathermanous Selenium Rubber place on Amp Board AU1 AU2 AU3	16×11×1mm
40	331-90033702-Q200	1	Shade for volume knob	F 33×F 7×0.2mm
41	500-10200702-0000	2	Sponge with double glue	20×7×2mm
42	555-A01000RC-0010	1 set	Remote control	
43	162-J00TJC13-0200	1	JBL speaker jack TJC1-3 JBL TJC1-3	Red 032C with JBL logo
44	162-J00TJC13-0100	1	JBL speaker jack TJC1-3 JBL TJC1-3	Whitie with JBL logo
45	162-J00TJC13-0500	1	JBL speaker jack TJC1-3 JBL TJC1-3	Green 361C with JBL logo
46	162-J00TJC13-0300	1	JBL speaker jack TJC1-3 JBL TJC1-3	Cool Grey 7C with JBL logo
47	162-J00TJC13-0600	1	JBL speaker jack TJC1-3 JBL TJC1-3	Process Blue C with JBL logo
48	331-90146258-0500	1	VFD filter VFD	for VFD 146×25.8mm
49	500-05022050-0000	1	Pyrocondensation cannula	cover magnetism annulus of AC cord f 22×50mm
50	205-0JSHM248-1000	1	Magnetism annulus M248	for AC cord
51	313-AGDSC100-0001	1	Laser precausion mark	stick on loader
52	313-AGDSC100-0002	1	Laser precausion guide	stick on loader
53	500-01012060-0010	2	Viscose band	12×60mm
CONNECT CABLE				
54	160-E0050250-0A00	1	5 pin, long 250mm, two ends with 2.0mm space connector, different link sides	connect loader and mainboard
55	160-E0060320-0A00	1	6 chip, long 320mm, two ends with 2.0mm space connector, different link sides	connect loader and mainboard
56	160-E0020040-0A00	1	2 pin, long 40mm, one end with 2.54mm space connector	connect front panel board and power switch
57	160-E0090230-0A00	1	9 pin, long 230mm, two ends with 2.0mm space connector, same link sides	connect front panel board and mainboard

DSC1000 Component List

58	160-E0100160-0A00	1	10 pin, long 160mm, one end with 2.0mm connector and another end with 2.54mm connector, different link sides	connect power supplier board and mainboard
59	160-E0050180-0A00	1	5 pin, long 180mm, one end with 2.0mm connector and another end with 2.54mm connector, same link sides	connect power supplier board and amplifier board
60	160-EG020180-0A00	1	2 pin, long 180mm, two ends with VH-3Y connector, different link sides	connect power supplier board and amplifier board
61	161-16070100-0000	1	16 pin, long 50mm, 1.0mm space, flat cable, same link sides	connect mainboard and amplifier board
62	161-24070050-0000	1	11 pin, long 70mm, 1.25mm space, flat cable, same link sides	connect mainboard and tuner model
63	160-E0050340-5A00	1	5 pin with shield, long 340mm, two ends with 2.0mm space connector, same link sides	connect front panel board and mainboard
64	160-E0020600-2A00	1	2 pin, long 600mm, one end with VH-3Y connector	connect power supplier board and power switch
65	160-E0240170-JA00	1	24 pin, long 170mm, 0.5mm space, flat cable, different link sides	connect loader and mainboard
66	160-E0030060-3A00	1	3 pin, long 60mm, two ends with 2.54mm space connector, same link sides	connect power supplier board and front panel board
67	162-A0000350-0000	1	Power cord with 350mm fixture, with magnetism annulus	EU version
68	162-A0000042-0000	1	1 pin with 42 line, one end with alumium fastener	connect A point with B point of Q6 on SMPS
WHOLE PART				
69	206-0000DV34-2202	1	LOADER	SANYO DV34
70	555-A01000RC-0010	1	Remote control	DSC1000
71	170-APS5EA07-0000	1	Power switch (20mm)	PS5E-A-078
72		1	FM tuner model	
	204-001E803A-0300			TFCF1E803A, for EU version,
ASSEMBLED PCB				
73	300-C1239CPV-0002	1	Mainboard	1239C-PV1
74	300-O01241C-0002	1	Amplifier board	1241C
75	300-D001242C-0002	1	Front panel board	1242C
76	300-K001354C-0001	1	Remote control board	1354C

DSC1000 FRONT BOARD

Item	Parts No.	Qty	LOCA.NO.	DESCRIPTION	SPECIFICATION	Remarks
RESISTOR						
1	131-B00000JT-0000	2	3R40 3R41	Resistor, chip	0O 1/8W 0805 5%	
2	131-B00000JT-0000	2	3R15 3R21	Resistor, chip	0O 1/8W 0805 5%	
3	131-B01010JT-0000	3	3R17 3R19 3R38	Resistor, chip	100O 1/8W 0805 5%	
4	131-B01047JT-0000	1	3R7	Resistor, chip	470O 1/8W 0805 5%	
5	131-B02010JT-0000	1	3R4	Resistor, chip	1KO 1/8W 0805 5%	
6	131-B02022JT-0000	1	3R24	Resistor, chip	2.2KO 1/8W 0805 5%	
7	131-B02047JT-0000	10	3R3 3R9 3R10 3R25 3R26 3R27 3R31 3R34 3R35 3R36	Resistor, chip	4.7KO 1/8W 0805 5%	
8	131-B03010JT-0000	6	3R1 3R2 3R14 3R20 3R22 3R23	Resistor, chip	10KO 1/8W 0805 5%	
9	131-B03015JT-0000	1	3R5	Resistor, chip	15KO 1/8W 0805 5%	
10	131-B03020JT-0000	1	3R13	Resistor, chip	20KO 1/8W 0805 5%	
11	131-B04010JT-0000	1	3R18	Resistor, chip	100KO 1/8W 0805 5%	
12	131-T41030JA-0000	1	3R11	Fixed carbon film	300O 1/4W 5%	
13	130-T42010JA-0000	1	3R12	Fixed carbon film	1KO 1/4W 5%	
14	131-A1608C27-0000	2	ESD1 ESD2	Zinc oxide varistor, for ESD	AVR-M1608C270MTABB, 0603	
CAPACITOR						
15	141-C0B022PH-KT00	2	3C16 3C17	Capacitor, multilayer ceramic, chip	22PF 50V J NPO 0805	
16	140-DCB030UD-0A00	1	3C18	Capacitor, multilayer ceramic, chip	30PF 50V J NPO 0805	
17	140-DCB110UD-0A00	3	3C4 3C19 3C20	Capacitor, multilayer ceramic, chip	100PF 50V J NPO 0805	
18	140-DCB182UD-0A00	2	3C23 3C24	Capacitor, multilayer ceramic, chip	820PF 50V J NPO 0805	
19	141-C0B312PH-KT00	1	3CB8	Capacitor, multilayer ceramic, chip	0.012µF 50V K X7R 0805	
20	141-C0B347PH-KT00	2	3C21 3C22	Capacitor, multilayer ceramic, chip	0.047µF 50V K X7R 0805	
21	141-C0B410PH-KT00	6	3CB1 3CB3 3CB4 3CB6	Capacitor, multilayer ceramic, chip	0.1µF 50V Z Y5V 0805	
22	141-C0B510PH-KT00	1	3CB7	Capacitor, multilayer ceramic, chip	1µF 50V Z Y5V 0805	
23	141-C0B522PH-KT00	2	3CB2 3CB5	Capacitor, multilayer ceramic, chip	2.2µF 50V Z Y5V 0805	
24	140-DCA110UE -0A00	1	3C5	CD-100uF/16V	100µF 16V 20%	microminiature
25	140-DCA047UD -0A00	2	3C2 3C3	CD-47uF/10V	47µF 10V 20%	microminiature
26	140-DCA022UG -0A00	9	3C1 3C8 3C9 3C10 3C11 3C12 3C13 3C14 3C15	CD-22uF/35V	22µF 35V 20%	microminiature
27	140-DCA110UG -0A00	2	3C6 3C7	CD-100uF/35V	100µF 35V 20%	microminiature

DSC1000 FRONT BOARD

Item	Parts No.	Qty	LOCA.NO.	DESCRIPTION	SPECIFICATION	Remarks
TRANSISTOR						
28	111-B01N4148-0A00	11	3D1 3D2 3D3 3D4 3D5 3D6 3D7 3D8 3D9 3D10 3D12	Diode	1N4148, In-line Package	
29	121-000S8050-T400	2	3Q2 3Q3	Transistor	8050 SMD	
30	121-000S8550-T300	3	3Q1 3Q4 3Q5	Transistor	8550 SMD	
31	110-D000C062-0T00	1	3DZ1	Zener Diode	Zener Diode, 6.2V, In-line Package	
OSCILLATOR						
32	217-00400003-2100	1	3Y1	Fundamental. Oscillator	4.000MHz, In-line Package	
TOUCH SWITCH						
33	170-C0000004-0000	6	3K1 3K2 3K3 3K4 3K5 3K6	Touch switch	6x6	
LED						
34	110-FHFT503C-AT00	2	3LCD1 3LCD2	Diode, color is blue&amber	HFT503CPBOF 3, 3P, In-line Package	
IR RECEIVER						
35	105-0HL38B17-1000	1	3IR1	IR receiver	HL38B17, 3P, In-line Package	
VFD						
36	190-VFD1301F-0000	1	VFD	VFD	VFD22 1301F	
ENCODER						
37	133-03ED1612-0000	1	CON1	Volume encoder	ED1612-24-24HC-F20(Z)	
HEADPHONE JACK						
38	187-CKX33509-0000	1	3J5	Headhpone jack	CKX3-3.5-09	
POWER SWITCH						
39	170-APS5EA07-0000	1	FRONT PANEL	Power switch	PS5E-A-078	
IC						
40	102-00LM9022-7000	1	3U3	IC, NS, Vacuum Fluorescent Display Filament Driver	LM9022, 8P, SO8	
41	102-PIC16C56-7000	1	3U1	IC, Microchip, MCU	PIC16C56A, 18P, DIP	firmware burn-in
42	102-LC75710N-0000	1	3U2	IC, Sanyo, VFD driver	LC75710NE, SMD	
CONNECTOR						
43	180-0000PH5A-5100	1	3J3	Connector	PH-5A	
44	180-0000PH9A-5100	1	CON3	Connector	PH-9A	
45	180-0TJC302A-5100	1	3J1	Connector	TJC3-2A	
46	180-0TJC303A-5100	1	3J4	Connector	TJC3-3A	

DSC1000 MAIN BOARD

Item	Parts No.	Qty	LOCA.NO.	DESCRIPTION	SPECIFICATION	Remarks
				TRANSISTOR		
1	131-A00000JT-0000	10	R1 AR74 R116 R136 FB24 FB25 DR1 DR2 DR3 R143	Resistor, chip	0O 1/10W 0603 5%	
2	131-A00010FT-0000	9	R61 R62 R63 R114 3R2 3R4 DR4 DR5 DR6	Resistor, chip	10O 1/10W 0603 5%	
3	131-A00022JT-0000	6	R29 R30 R31 R32 R33 R202	Resistor, chip	22O 1/10W 0603 5%	
4	131-A00027JT-0000	2	R145 R146	Resistor, chip	27O 1/10W 0603 5%	
5	131-A00033JT-0000	5	R184 R185 R186 R189 R190	Resistor, chip	33O 1/10W 0603 5%	
6	131-A00056JT-0000	2	R149 R150	Resistor, chip	56O 1/10W 0603 5%	
7	131-B00075JT-4000	20	R9 R37 R39 R40 R41 R42 R43 R44 R45 R46 R47 R48 R49 R50 R51 R52 AR3 AR4 AR5 AR6	Resistor, chip	75O 1/10W 0603 1%	
8	131-A00082JT-0000	3	R182 R183 R187	Resistor, chip	82O 1/10W 0603 5%	
9	131-A00091JT-0000	1	AR10	Resistor, chip	91O 1/10W 0603 5%	
10	131-A01010JT-0000	5	R117 R137 R199 RR11 RR12	Resistor, chip	100O 1/10W 0603 5%	
11	131-A01015JT-0000	2	R89 R98	Resistor, chip	150O 1/10W 0603 5%	
12	131-A00187FT-4000	2	R11 R12	Resistor, chip	187O 1/10W 0603 1%	
13	131-A01022JT-0000	4	RR6 RR7 RR8 RR9	Resistor, chip	220O 1/10W 0603 5%	
14	131-A01033JT-0000	2	R56 R67	Resistor, chip	330O 1/10W 0603 5%	
15	131-A01047JT-0000	4	R193 R211 R212 R213	Resistor, chip	470O 1/10W 0603 5%	
16	131-A01068JT-0000	5	R55 R66 3R3 3R9	Resistor, chip	680O 1/10W 0603 5%	
17	131-A02010JT-0000	9	R78 R191 R192 R194 RR3 R173A1 R173B1 R173C1 R173D1	Resistor, chip	1KO 1/10W 0603 5%	
18	131-A02012JT-0000	1	R204	Resistor, chip	1.2KO 1/10W 0603 5%	
19	131-A01178FT-4000	2	R57 R68	Resistor, chip	1.78KO 1/10W 0603 1%	
20	131-A02020JT-0000	2	2R11 2R12	Resistor, chip	2KO 1/10W 0603 5%	
21	131-A02022JT-0000	1	R139	Resistor, chip	2.2KO 1/10W 0603 5%	
22	131-A02027JT-0000	5	R17 R18 R19 R20 AR11	Resistor, chip	2.7KO 1/10W 0603 5%	
23	131-A02030JT-0000	2	R81 R120	Resistor, chip	3KO 1/10W 0603 5%	
24	131-A02033JT-0000	6	2R3 2R4 2R6 2R7 2R8 2R9	Resistor, chip	3.3KO 1/10W 0603 5%	
25	131-A02039JT-0000	1	R195	Resistor, chip	3.9KO 1/10W 0603 5%	
26	131-A02047JT-0000	26	R4 R7 R15 R53 R65 R93 R99 R104 R105 R106 R107 R108 R109 R110 R111 R113 AR2 AR12 R4B1 R5A1 R121 R122 R123 2R10 AR7 R144	Resistor, chip	4.7KO 1/10W 0603 5%	
27	131-A01475FT-4000	2	R54 R64	Resistor, chip	4.75KO 1/10W 0603 1%	
28	131-A02056JT-0000	2	R133 R197	Resistor, chip	5.6KO 1/10W 0603 5%	
29	131-A02062JT-0000	1	R128	Resistor, chip	6.2KO 1/10W 0603 5%	
30	131-A02068JT-0000	2	R86 R97	Resistor, chip	6.8KO 1/10W 0603 5%	
31	131-A02075JT-0000	6	R58 R69 R126 R196 R131 R134	Resistor, chip	7.5KO 1/10W 0603 5%	
32	131-A02082JT-0000	6	R88 R90 R92 R94 R96 R101	Resistor, chip	8.2KO 1/10W 0603 5%	

DSC1000 MAIN BOARD

Item	Parts No.	Qty	LOCA.NO.	DESCRIPTION	SPECIFICATION	Remarks
33	131-A03010JT-0000	54	R2 R3 R5 R6 RR1	Resistor, chip	10KO 1/10W 0603 5%	
			RR2 RR10 R16 R21 R22			
			R23 R24 R27 R34 R35			
			R36 R38 R59 R60 R71			
			R72 R79 R80 R84 R85			
			R112 R118 R125 R130 R132			
			R135 R151 R152 R153 R154			
			R155 R158 R159 R167 R172			
			R175 R176 R177 R178 R180			
			R188 R205 R206 R207 R208			
			R209 R215 R156 R157			
34	131-A03015JT-0000	4	R26 R119 R210 2R13	Resistor, chip	15KO 1/10W 0603 5%	
35	131-A03018JT-0000	3	R124 R141 R201	Resistor, chip	18KO 1/10W 0603 5%	
36	131-A03020JT-0000	4	3R1 3R5 3R6 3R10	Resistor, chip	20KO 1/10W 0603 5%	
37	131-A03027JT-0000	1	R203	Resistor, chip	27KO 1/10W 0603 5%	
38	131-A03033JT-0000	1	R127	Resistor, chip	33KO 1/10W 0603 5%	
39	131-A03047JT-0000	1	R115	Resistor, chip	47KO 1/10W 0603 5%	
40	131-A03068JT-0000	1	R181	Resistor, chip	68KO 1/10W 0603 5%	
41	131-A04010JT-0000	5	R28 R95 R102 R129 3R7	Resistor, chip	100KO 1/10W 0603 5%	
42	131-A05010JT-0000	4	R14 R138 R198 3R8	Resistor, chip	1MO 1/10W 0603 5%	
43	131-B0C022JT-0000	2	R147 R148	Resistor, chip	2.2O 1/10W 0805 5%	
44	132-0008033J-T100	4	RN13 RN16 RN17 RN18	Resistor, thick film chip network	33Ox4 1/16W 0603 5%	
45	132-0008082J-T100	1	RN12	Resistor, thick film chip network	82Ox4 1/16W 0603 5%	
46	132-0008347J-T100	1	RN2	Resistor, thick film chip network	47KOx4 1/16W 0603 5%	
47	130-T40075JT-0000	1	R75	Fixed carbon film	75O 1/4W 5%	
48	130-T41015JT-0000	1	2R5	Fixed carbon film	150O 1/4W 5%	
49	130-T42010JT-0000	2	2R1 2R2	Fixed carbon film	1KO 1/4W 5%	
50	130-M1608C27-0000	8	ESD4 ESD5 ESD6 ESD7 ESD8 ESD9 ESD10 ESD11	Zinc oxide varistor, for ESD	AVR-M1608C270MTABB, 0603	
CAPACITOR						
51	141-C0AC68PH-KT00	1	C24	Capacitor,multilayer ceramic, chip	6.8PF 50V J NPO 0603	
52	141-C0A010PH-KT00	4	C21 C124 C125 C151	Capacitor,multilayer ceramic, chip	10PF 50V J NPO 0603	
53	141-C0A020PH-KT00	6	2C4 2C8 C31 C35 C37 C43	Capacitor,multilayer ceramic, chip	20PF 50V J NPO 0603	
54	141-C0A022PH-KT00	3	C22 C23 C47	Capacitor,multilayer ceramic, chip	22PF 50V J NPO 0603	
55	141-C0A033PH-KT00	3	C91 C95 C119	Capacitor,multilayer ceramic, chip	33PF 50V J NPO 0603	
56	141-C0A047PH-KT00	7	C20 C81 C83 C108 C115 C60 C61 C87	Capacitor,multilayer ceramic, chip	47PF 50V J NPO 0603	
57	141-C0A051PH-KT00	2	C38 C42	Capacitor,multilayer ceramic, chip	51PF 50V J NPO 0603	
58	141-C0A120PH-KT00	2	C59 C74	Capacitor,multilayer ceramic, chip	200PF 50V J NPO 0603	
59	141-C0A122PH-KT00	1	C109	Capacitor,multilayer ceramic, chip	220PF 50V J NPO 0603	
60	141-C0A127PH-KT00	2	C90	Capacitor,multilayer ceramic, chip	270PF 50V J NPO 0603	
61	141-C0A156PH-KT00	3	C26 C72 C94	Capacitor,multilayer ceramic, chip	560PF 50V J NPO 0603	
62	141-C0A210PH-KT00	1	C139	Capacitor,multilayer ceramic, chip	1000PF 50V J NPO 0603	
63	141-C0A215PH-KT00	1	C110	Capacitor,multilayer ceramic, chip	1500PF 50V J NPO 0603	
64	141-C0B256PH-KT00	1	C116	Capacitor,multilayer ceramic, chip	5600PF 50V J NPO 0603	
65	141-C0A310PH-KT00	5	C82 C84 C114 C158 C161	Capacitor,multilayer ceramic, chip	0.01UF 50V K X7R 0603	

DSC1000 MAIN BOARD

Item	Parts No.	Qty	LOCA.NO.	DESCRIPTION	SPECIFICATION	Remarks
66	141-C0A318PH-KT00	3	C122 C28 C36	Capacitor,multilayer ceramic, chip	0.018UF 50V K X7R 0603	
67	141-C0A333PH-KT00	1	C112	Capacitor,multilayer ceramic, chip	0.033UF 50V K X7R 0603	
68	141-C0A410PH-KT00	136	CB1-CB135 C85	Capacitor,multilayer ceramic, chip	0.1UF 50V Z Y5V 0603	
69	141-C0A510PH-KT00	3	C150 C156 C157	Capacitor,multilayer ceramic, chip	1UF 50V Z Y5V 0603	
70	141-C0B110PH-KT00	2	C54 C64	Capacitor,multilayer ceramic, chip	100PF 50V J NPO 0805	
71	141-C0B168PH-KT00	2	C67 C68	Capacitor,multilayer ceramic, chip	680PF 50V J NPO 0805	
72	141-C0B210PH-KT00	2	C56 C69	Capacitor,multilayer ceramic, chip	1000PF 50V J NPO 0805	
73	140-DCA001UD -0A00	9	C41 C44 EC22 EC23 EC24 EC25 3C1 3C2 3C3	Capacitor, AL.electrolytic	1μF 10V 20%	
74	140-DCAC22UD-0A00	1	C93	Capacitor, AL.electrolytic	2.2μF 10V 20%	
75	140-DCAC47UD -0A00	2	EC43 EC44	Capacitor, AL.electrolytic	4.7μF 10V 20%	
76	140-DCA010UE-0A00	12	EC15 EC16 EC20 EC21 EC28 EC29 EC33 EC34 EC35 EC36 EC39 C12	Capacitor, AL.electrolytic	10μF 16V 20%	
77	140-DCA022UD-0A00	3	C27 C40 C46	Capacitor, AL.electrolytic	22μF 10V 20%	
78	140-DCA047UE-0A00	24	C6 C14 C15 C29 C30 C49 C51 C58 C66 C75 C79 C80 C99 C100 C101 EC9 EC10 EC12 EC13 EC14 EC19 EC27 EC42 EC45	Capacitor, AL.electrolytic	47μF 16V 20%	
79	140-DCA110UD-0A00	7	C11 C25 C39 C45 EC1 EC2 EC32	Capacitor, AL.electrolytic	100μF 10V 20%	
80	140-DCA110UF-0A00	4	C17 C76 EC30 EC31	Capacitor, AL.electrolytic	100μF 25V 20%	
81	140-DCA122UE -0A00	18	EC3 EC4 EC5 EC6 EC7 EC8 EC11 EC40 EC41 C1 C3 C8 C16 C19 C34 C77 3C6 3C7	Capacitor, AL.electrolytic	220μF 16V 20%	
82	140-DCA110UH -0A00	2	C4 C7	Capacitor, AL.electrolytic	100μF 50V 20%	
83	140-DCA133UE -0A00	3	C52 C53 C48	Capacitor, AL.electrolytic	330μF 16V 20%	
84	140-DCA147UE -0A00	3	C5 C13 C18	Capacitor, AL.electrolytic	470μF 16V 20%	
OSCILLATOR						
85	217-02700003-2200	1	Y1	Fundamental. Oscillator	27MHz, In-line Package	
86	217-03386003-2200	1	Y2	Fundamental. Oscillator	33.86MHz, In-line Package	
87	217-04333003-2200	1	Y3	Fundamental. Oscillator	4.332MHz, In-line Package	
COIL, FILTER						
88	151-3B0B39K1-A000	1	L18	Inductor, multilayer ceramic, chip	0.39μH HDW0805UC3R9JGT, 0805	
89	151-3B0B68K1-A000	2	L16 L17	Inductor, multilayer ceramic, chip	0.68μH HDW0805UC6R8JGT, 0805	
90	154-C00EJ219-0000	2	Z1 Z2	Tuner 19k filter	EJ219, In-line Package	
91	152-1A205001-A000	17	FB10 FB11 FB12 FB13 FB14 FB15 FB18 FB19 FB20 FB21 FB22 FB23 FB26 FB31 FB32 FB33 FB34	Bead, chip	Impedance is 50O, 0603	

DSC1000 MAIN BOARD

Item	Parts No.	Qty	LOCA.NO.	DESCRIPTION	SPECIFICATION	Remarks
92	152-1B205001-A000	37	FB1 FB2 FB4 FB6 FB7	Bead, chip	Impedance is 500, 0805	
			FB8 FB27 FB28 FB29 L1			
			L2 L3 L4 L5 L6			
			L7 L8 L9 L10 L11			
			L12 L13 L14 L15 L19			
			L20 L21 L22 L23 L24			
			L25 L26 L28 L29 L30			
			L31 L33			
93	152-10205001-T000	4	FB3 FB5 FB9 FB30	Bead, leaded fixed	Impedance is 500, In-line Package	
DIODE						
94	110-B0IN4148-0A00	5	D15 D17 D18 D19 D20	Diode	1N4148, In-line Package	
95	110-B0IN5393-0A00	3	D24 D26 D27	Diode	1N5393, In-line Package	
96	111-B0IN4148-0A00	2	D16 D25	Diode	1N4148, SMD	
TRANSISTOR						
97	121-00009014-T000	7	Q3 Q4 Q5 Q6 Q7 Q8 Q13	Transistor	9014, SMD	
98	121-00008050-T400	6	Q23 Q24 Q25 2Q4 2Q5 Q20	Transistor	8050, SMD	
99	121-00008550-T300	5	Q1 Q2 Q12 Q17 Q26	Transistor	8550, SMD	
100	121-DTC343TK-T400	7	Q9 Q10 Q19 Q27 2Q1 2Q2 2Q3	Transistor, ROHM	DTC343TK, SMD	
101	121-DTA114EK-T400	1	Q22	Transistor, ROHM	DTA114EKA, SMD	
102	121-00003018-T400	1	Q18	Silicon N-channel MOSFET, ROHM	2SK3018, SMD	
103	120-00008050-A400	1	Q16	Transistor	8050, In-line Package	
104	120-00008550-A300	1	Q15	Transistor	8550, In-line Package	
IC						
105	102-AN8785SB-6000	1	U1	IC, Panasonic, Motor Driver	AN8785SB, HSOP042	SMD
106	102-S018EZ01-0000	1	U2	IC, Sharp, Voltage Regulator	O18EZ01, PQ025	SMD
107	105-00079L05-8000	1	U3	IC, NS, Voltage Regulator	79L05, 3P, TO-92	In-line Package
108	102-0AML3390-1000	1	U4	IC, Amlogic, decoder	AML3390DTS, 208P, PQFP	SMD
109	102-074HCT14-6000	1	U5	IC, TI, 8-bit serial-in/ parallel-out shift register	74HC164, 14P, SO14	SMD
110	101-29LV90EC-8402	1	U7	IC, AMD, Flash	AM29LV160DB-90EC, 48P, TSOP48	SMD, firmware burn-in
	101-29LV1670-8402			IC, Fujitsu, Flash	MBM29LV160BE-70P, 48P, TSOP48	
111	101-AT27C020-0000	1	U8	IC, Atmel Servo FLASH.	AT27C020-70ZC, PLCC	SMD, firmware burn-in
	101-PT28C020-0000			IC, PT Servo FLASH.	PT28C020-70JC, PLCC	
112	101-103S47JR-0000	1	U9	IC, Panasonic, Servo chip	MN103S47JRB, 176P, QFP	SMD
113	101-HY57V641-0000	1	U6	IC, Hyundai, SDRAM	HY57V641620HGT-7, 54P, TSOP54	SMD
114	101-0NJM4558-0000	1	U12	IC, JRC, Pre-amp	NJM4558, 8P, SOP	SMD
115	101-000LM833-0000	2	U11 U20	IC, NS, Pre-amp	LM833, 8P, SOP	SMD
116	101-BH7862FS-0000	1	U14	IC, Rohm, Video Buffer	BH7862FS, 32P, SSOP-A32	SMD
117	101-00LM4880-0000	1	3U2	IC, NS, Audio Power Amplifier	LM4880, 8P, SOP8	SMD
118	101-00024C64-0000	1	U15	IC, Atmel, EEPROM	AT24C64, 8P, SOP	SMD, firmware burn-in
119	101-00WM8728-0000	1	U16	WM8728, 20P, SSOP20	IC, Wolfson, Audio DAC	SMD
120	105-00078L05-8000	3	U10 U13 U19	IC, NS, Voltage Regulator	78L05, 3P, TO-92	In-line Package
121	101-00CD4052-0000	1	U21	IC, NS, Analog Multiplexer	CD4052, 16P, SOP16	SMD

DSC1000 MAIN BOARD

Item	Parts No.	Qty	LOCA.NO.	DESCRIPTION	SPECIFICATION	Remarks
122	101-074HC158-0000	1	U22	IC, TI, Data selectors	74HC158, 16P, SOP16	SMD
123	101-00CS5333-0000	1	U23	IC, Crystal, A/D Converter	CS5333, 16P, TSSOP16	SMD
124	105-00007809-0000	1	U24	IC, NS, Voltage Regulator	L7809, 3P, TO-220	In-line Package
125	101-00BU1924-0000	1	U25	IC, Rohm, RDS decoder	BU1924, 16P, SOP16	SMD
126	101-074HCT14-0000	1	U26	IC, Philips, Hex inverting Schmitt trigger	74HCT14, 14P, SO14	SMD
JACK, CONNECTOR						
127	181-00050241-0100	1	CN3	Connector	24pin, 0.5mm, SMD	
128	187-1FA513RZ-0540	1	CN2	Jack, Sharp, Fiber optic input jack, with shutter, new model	GP1FA513RZ, In-line Package	
129	181-00125111-0100	1	CN1	Connector	11pin, 1.25mm, DIP	
130	180-0000PH5A-5100	2	CN4 CN6	Connector	PH-5A, 5P, In-line Package	
131	180-0000PH6A-5100	1	CN5	Connector	PH-6A, 6P, In-line Package	
132	180-0000PH9A-5100	1	CON6	Connector	PH-9A, 5P, In-line Package	
133	180-000PH10A-5100	1	CON7	Connector	PH-10A, 6P, In-line Package	
134	187-00EV021A-0740	1	CON3	Jack, QiangSheng , SCART output jack, old model	EV-021A, SCART, In-line Package	
	187-0CS101FS-0740			Jack, YuanChang , SCART output jack, improved model for ESD issue	CS-101 full shield, SCART, In-line Package	
135	186-AV38413G-1300	1	CON4	Jack, YuanChang , Component Video output jack Green Blue Red color	AV3-8.4-13G, In-line Package	
136	181-000VIDEO-2200	1	CON8	Jack, YuanChang , Video&S-Video output jack	yellow and S-Video	
137	186-00AV4845-1300	1	CON9	Jack, YuanChang , Audio output&input jack	AV4-8.4-5G, In-line Package Up white and down red	
138	186-0AV1846G-1300	1	CON5	Jack, YuanChang , Coaxial output jack	AV1-8.4-6G, In-line Package	
139	181-00100162-2200	1	CON1	Connector	16pin, 1mm, connector, DIP	

DSC1000 AMP BOARD

Item	Parts No.	Qty	LOCA.NO.	DESCRIPTION	SPECIFICATION	Remarks
CAPACITOR						
1	141-C0A027PH-KT00	1	C2	Capacitor, multilayer ceramic, chip	27PF 50V J NPO 0603	
2	141-C0A047PH-KT00	1	AC17	Capacitor, multilayer ceramic, chip	47PF 50V J NPO 0603	
3	141-C0A110PH-KT00	1	C5	Capacitor, multilayer ceramic, chip	100PF 50V J NPO 0603	
4	141-C0A122PH-KT00	1	AC22	Capacitor, multilayer ceramic, chip	220PF 50V J NPO 0603	
5	141-C0A210PH-KT00	2	AC6 C4	Capacitor, multilayer ceramic, chip	1000PF 50V J NPO 0603	
6	141-C0A315PH-KT00	1	C1	Capacitor, multilayer ceramic, chip	0.015uF 50V K X7R 0603	
7	141-C0A410PH-KT00	42	CB2 CB3 CB4 AC1 AC2 AC3 AC4 AC7 AC8 AC9 AC10 AC13 AC14 AC15 AC18 AC19 AC23 AC25 AC26 AC27 AC29 AC31 AC32 AC40 AC42 AC50 AC51 AC55 AC59 AC60 AC68 AC70 AC78 AC79 AC83 AC87 AC88 AC98 AC96 AC100 AC101 AC102	Capacitor, multilayer ceramic, chip	0.1uF 50V Z Y5V 0603	
8	141-C0B210PH-KT00	10	CB7 CB8 CB9 CB10 CB11 CB12 CB13 CB14 CB15 CB16	Capacitor, multilayer ceramic, chip	1000PF 50V J NPO 0805	
9	141-C0B212PH-KT00	1	AC20	Capacitor, multilayer ceramic, chip	1200PF 50V J NPO 0805	
10	141-C0B410PH-KT00	20	AC28 AC33 AC38 AC41 AC43 AC47 AC52 AC54 AC56 AC61 AC66 AC69 AC71 AC75 AC80 AC82 AC84 AC89 AC94 AC97	Capacitor, multilayer ceramic, chip	0.1uF 50V Z Y5V 0805	
Item	Parts No.	Qty	LOCA.NO.	DESCRIPTION	SPECIFICATION	Remarks
11	141-C0C147PH-KT00	5	AC30 AC46 AC58 AC74 AC86	Capacitor, multilayer ceramic, chip	470PF 50V J NPO 1206	
12	140-ACA001UH-KT00	5	AC37 AC44 AC65 AC72 AC93	Solid Electrolyte Tantalum Chip Capacitor	1UF 50V	
13	140-ACA022UD-KT00	2	AC11 AC24	Solid Electrolyte Tantalum Chip Capacitor	22UF 0V	
14	140-0LGB68UI-KT00	5	AC36 AC49 AC64 AC77 AC92	Box-type metallized polyester film capacitor	0.68uF 63V J NPO P=5	Faratronic CL23B
15	140-DCA010UF-KT00	1	EC5	Capacitor, AL.electrolytic	10μF 25V 20%	
16	140-DCA110UE-KT00	3	EC1 EC2 AC12	Capacitor, AL.electrolytic	100μF 16V 20%	
17	140-DCA210UH-KT00	3	AC34 AC62 AC90	Capacitor, AL.electrolytic	1000μF 50V 20%	
18	140-DCA047UE-KT00	2	EC3 EC4	Capacitor, AL.electrolytic	47μF 16V 20%	
TRANSISTOR						
19	110-B0IN4148-0A00	2	D4 D5	Diode	1N4148, SMD	
20	121-DTC343TK-T400	1	Q2	Transistor, ROHM	DTC343TK, SMD	

DSC1000 AMP BOARD

Item	Parts No.	Qty	LOCA.NO.	DESCRIPTION	SPECIFICATION	Remarks
RESISTOR						
21	131-A00000JT-0000	6	RR1 RR2 RR3 RR7 RR8 RR9	Resistor, chip	0O 1/10W 0603 5%	
22	131-A01015JT-0000	1	R11	Resistor, chip	150O 1/10W 0603 5%	
24	131-A01027JT-0000	1	R15	Resistor, chip	270O 1/10W 0603 5%	
25	131-A02010JT-0000	1	R8 R12	Resistor, chip	1kO 1/10W 0603 5%	
26	131-A02015JT-0000	3	R7 R9 R10	Resistor, chip	1.5kO 1/10W 0603 5%	
27	131-A02033JT-0000	1	AR5	Resistor, chip	3.3kO 1/10W 0603 5%	
28	131-A03010JT-0000	7	R3 R4 R5 R6 AR9 AR16 AR23	Resistor, chip	10kO 1/10W 0603 5%	
29	131-A03047JT-0000	1	R13	Resistor, chip	47kO 1/10W 0603 5%	
30	131-C0C047JT-0000	10	AR6 AR7 AR10 AR11 AR13 AR14 AR17 AR18 AR20 AR21	Resistor, chip	4.7O 1/4W 1206 5%	
31	131-C00015JT-0000	5	AR8 AR12 AR15 AR19 AR22	Resistor, chip	15O 1/4W 1206 5%	
COIL, FILTER						
32	152-0B0130K1-T000	2	L2 L3	Bead, chip	Impedance is 300O, 0805	
33	151-105015K1-T000	10	LL1-LL10	Magnetic shielding Inductor	15UH, DIP	12x16.5mm
34	152-0B0050K1-T000	1	FB1	Bead, chip	Impedance is 50O, 0805	
IC						
35	101-0DDX2100-0000	3	AU1 AU2 AU3	IC, Apogee, Power Device	DDX2100, 36P	
36	101-0DDX8001-0000	1	U3	IC, Apogee, Digital Audio Processor	DDX8001, 64P, TQFP64	
37	101-AAT3522I-0000	1	U2	IC, Analogic, Microprocessor Reset Circuit	AAT3522IGY-3.08, 3P, SST3	
38	101-0NJM4558-0000	1	U4	IC, JRC, Pre-amp	NJM4558, 8P, SOP	
39	101-KT916133-0000	1	U1	IC, RichTek, Voltage Regulator	RT9161/A-33, 4P, SOT-23	
JACK, CONNECTOR						
40	180-000VH03A-3100	1	CN1	Connector	Vertical VH three holes two pins	White color
41	187-00001620-0000	1	CN5	Connector	16pin, 1mm, connector, DIP	
42	187-00000008-0000	1	CN4	Amplifier output jack	Six channels, In-line Package	
43	186-0AV1846G-1300	1	CN3	Jack, Sub output jack	AV1-8.4-6G, In-line Package	Purple color
44	180-0000PH5A-5100	1	CN6	Connector	PH-5A, 5P, In-line Package	
OTHER						
45	350-00161101-2600	3	Place on AU1 AU2 AU3	Diathermanous Selenium Rubber	16x11x1mm	

DSC1000 Power supply

Item	Parts No.	Qty	LOCA.NO.	DESCRIPTION	SPECIFICATION	Remarks
RESISTOR						
1	130-0RNTC5D9-0000	1	NTC	NTC thermistor	NTC-5D-9	
2	130-M10K471K-0000	1	RV1	Zinc oxide varistor	MYG10K471	
3	130-T30010KT-0000	4	R3 R5 R23 R25	Fixed carbon film	10R 1/6W 5%	
4	130-T31010KT-0000	1	R16	Fixed carbon film	100R 1/6W 5%	
5	130-T31022KT-0000	2	R13 R14	Fixed carbon film	220R 1/6W 5%	
6	130-T31033KT-0000	1	R30	Fixed carbon film	330R 1/6W 5%	
7	130-T32010KT-0000	3	R27 R31 R36	Fixed carbon film	1KO 1/6W 5%	
8	130-T32022KT-0000	4	R18 R19 R20 R29	Fixed carbon film	2.2KO 1/6W 5%	
9	130-T32051KT-0000	6	R11 R12 R15 R17 R32 R33	Fixed carbon film	5.1KO 1/6W 5%	
10	130-T33010KT-0000	1	R10	Fixed carbon film	10KO 1/6W 5%	
11	130-T33012KT-0000	1	R22	Fixed carbon film	12KO 1/6W 5%	
12	130-T33030KT-0000	1	R9	Fixed carbon film	30KO 1/6W 5%	
13	130-T34010KT-0000	1	R21	Fixed carbon film	100KO 1/6W 5%	
14	130-T40020KT-0000	1	R26	Fixed carbon film	200 1/4W 5%	
15	130-T41030KT-0000	1	R39	Fixed carbon film	300O 1/4W 5%	
16	130-T42010KT-0000	1	R35	Fixed carbon film	1KO 1/4W 5%	
17	130-T43047KT-0000	1	R4	Fixed carbon film	47KO 1/4W 5%	
18	130-T43030KT-0000	2	R7 R8	Fixed carbon film	30KO 1/4W 5%	
19	130-T44047KT-0000	1	R2	Fixed carbon film	470KO 1/4W 5%	
20	130-T45010KT-0000	1	R0	Fixed carbon film	1MO 1/4W 5%	
21	130-T55039KT-0000	1	R6	Fixed carbon film	3.9MO 1/2W 5%	
22	130-T63068KT-0000	2	R1 R24	Fixed carbon film	68KO 1W 5%	
23	130-T7B022KT-0000	1	R28	Fixed carbon film	0.22O 2W 5%	
24	130-T72010KT-0000	2	R34 R38	Fixed carbon film	1KO 2W 5%	
CAPACITOR						
25	140-CGA410PO-0A00	2	CX1 CX2	High-voltage metallized polyester film	0.1uF 275V 20%	X-type
26	140-CGA147PQ-0A00	4	CY3 CY4 CY5 CY6	High-voltage metallized polyester film	470PF 400V 20%	Y1-type
27	140-CGA122PQ-0A00	2	CY1 CY2	High-voltage metallized polyester film	220PF 400V 20%	Y1-type
28	140-CGA310PW-0A00	2	C1 C10	High-voltage metallized polyester film	0.01uF 1KV 20%	
29	140-DCA147UF-0A00	1	C13	Radial leads mlcc	470p 25V 20%	
30	140-DCA347UF-0A00	3	C2 C8 C14	Radial leads mlcc	0.047uF 25V 20%	
31	140-DCA410UF-0A00	6	C3 C4 C5 C6 C7 C11	Radial leads mlcc	0.1uF 25V 20%	
32	140-DCA272UF-0A00	1	C12	Radial leads mlcc	2700p 25V 20%	
33	140-DCA410UJ-0A00	1	C16	Metallized capacitor	0.1uF 100V 20%	
34	140-DC0001UH-0A00	2	EC22 EC25	Capacitor, AL.electrolytic	1uF 50V 20%	
35	140-DCAC22UF-0A00	1	EC10	Capacitor, AL.electrolytic	2.2uF 25V 20%	
36	140-DCA047UH-0A00	2	EC1 EC17	Capacitor, AL.electrolytic	47uF 50V 20%	
37	140-DCA110UE-0A00	3	EC23 EC24 C9	Capacitor, AL.electrolytic	100uF 16V 20%	
38	140-DCA110UF-0A00	4	EC3 EC4 EC5 EC6	Capacitor, AL.electrolytic	100uF 25V 20%	
39	140-DCF210UE-0A00	4	EC18 EC19 EC20 EC21	Capacitor, AL.electrolytic	1000uF 35V 105°C 20%	105°C
40	140-DCF210UE-0A00	2	EC13 EC14	Capacitor, AL.electrolytic	1000uF 16V 105°C 20%	105°C
41	140-DCA122UD-0A00	2	EC9 EC15	Capacitor, AL.electrolytic	220uF 10V 20%	
42	140-DCA122UE-0A00	4	EC7 EC8 EC11 EC12	Capacitor, AL.electrolytic	220uF 16V 20%	
43	140-DEF122UQ-0A00	1	EC16	Capacitor, AL.electrolytic	220uF 400V 105°C 20%	105°C
44	140-DCAC47UL-0A00	1	EC2	Capacitor, AL.electrolytic	4.7uF 160V 20%	

DSC1000 Power supply

Item	Parts No.	Qty	LOCA.NO.	DESCRIPTION	SPECIFICATION	Remarks
COIL, FILTER						
45	154-0L630110-0000	1	L7	Filter inductor	L630-100uH	
46	154-0L630010-0000	1	L6	Filter inductor	L630-10uH	
47	154-B0608020-0000	4	L2 L3 L4 L5	Filter inductor	0608-20uH	
48	154-B1601330-0000	1	LF2	Common Mode Choke	LCL-UF1601-30mH	
49	154-B003A320-0000	1	LF1	Common Mode Choke	LCL-203A-20mH	
50	154-B0000147-0000	1	LF3	Filter inductor	470uH	
51	154-AXIAL010-0000	1	FB1	Inductor	10uH	Axial0.4
DIODE						
52	110-A00KBUBM-0A00	1	BG1	Bridge Rectifiers	KBU8M, 4P, In-line Package	
53	110-B021DQ10-0A00	1	D7	Diode	21DQ10, In-line Package	
54	110-B031DQ06-0A00	1	D9	Diode	31DQ06, In-line Package	
55	110-B00FR107-0A00	8	D1 D2 D3 D5 D6 D8 D13 D15	Fast recovery rectifiers diode	FR107, In-line Package	
56	110-B0IN4148-0A00	4	D10 D11 D12 D16	Switching Diode	IN4148, In-line Package	
57	110-0FCH20A2-0A00	2	D17 D18	Schottky diode	FCH20A20, 3P, In-line Package	
58	110-B00FR207-0A00	1	D14	Fast recovery rectifiers diode	FR207, In-line Package	
59	110-D0000024-0A00	1	ZD1	Zener Diode	24V 1/2W, In-line Package	
60	110-D0000018-0A00	1	ZD2	Zener Diode	18V 1/2W, In-line Package	
61	110-0MCR1006-0A00	1	SC1	Silicon controlled rectifiers	MCR100-6, In-line Package	
TRANSISTOR, MOS-FET						
62	120-002N5551-A000	2	Q1 Q3	NPN Transistor	2N5551, In-line Package	
63	120-00009014-A000	2	Q4 Q7	NPN Transistor	C9014, In-line Package	
64	120-000C8550-A400	1	Q5	PNP Transistor	C8550, In-line Package	
65	120-FQA11N90-A400	1	Q6	MOS-FET	FQA11N90, In-line Package	
CONNECTOR						
66	180-000VH02A-3100	1	CN1	Connector	Vertical VH three holes two pins(orange)	Antiflaming
67	180-000VH02A-3110	2	CN2 CN3	Connector	Vertical VH three holes two pins(white)	Antiflaming
68	180-0TJC303A-5100	1	CN4	Connector	TJC3-3A, 3P, In-line Package	
69	180-0TJC310A-5100	1	CN5	Connector	TJC3-10A, 10P, In-line Package	
70	180-0TJC305A-5100	1	CN6	Connector	TJC3-5A, 5P, In-line Package	
IC						
71	105-00LM7805-8000	1	IC5	IC, NS, Voltage Regulator	LM7805,3P, In-line Package	
72	105-00007812-8000	1	IC3	IC, NS, Voltage Regulator	LM7812,3P, In-line Package	
73	105-00007912-8000	1	IC4	IC, NS, Voltage Regulator	LM7912,3P, In-line Package	
74	105-00BA033T-8000	1	IC6	IC, Rohm, Voltage Regulator	BA033T, 3P, In-line Package	
75	105-0FAN7554-8000	1	IC2	IC, Fairchild, Versatile PWM Controller	FAN7554, 8P, DIP	
76	105-KA5L0380-1000	1	IC1	IC, Fairchild, Power Switch	KA5L0380R, 3P, In-line Package	
77	105-000KA431-8000	2	IC7 IC8	IC, Fairchild, Precision Adjustable Voltage Regulator	KA431, 3P, In-line Package	
78	105-000PC817-1000	2	PH1 PH2	IC, Sharp, Photoelectric Coupler	PC817, 4P, DIP	
OTHER						
79		1	FU1	Fuse Holder	Fuse Holder	Antiflaming
80	210-00315250-2000	1	FU1	Fuse	T3.15AL/250V	
81	150-BC2802S1-0020	1	TR1	Transformer	BCK-ER2802S1	
82	150-BEC4201A-0020	1	TR2	Transformer	BCK-EC4201A	
83	385-00161235-5200	2	Match D17 D18	Heat sink	16x12x35mm	
84	385-00501935-5200	1	Match Q6	Heat sink	50x19x35mm	
85	500-09002024-0000	1	Match Q6	Talc nonconductor	20x24mm	

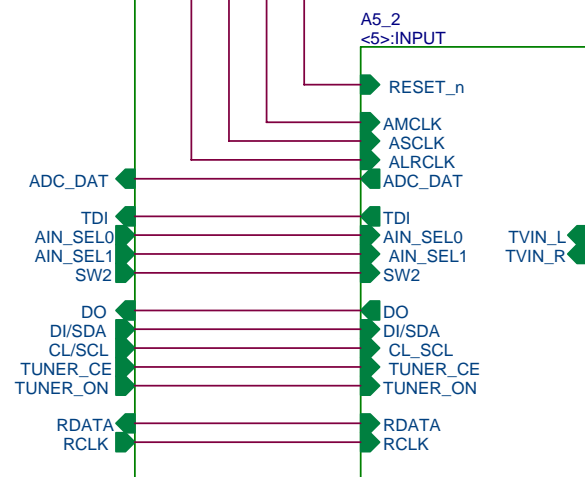
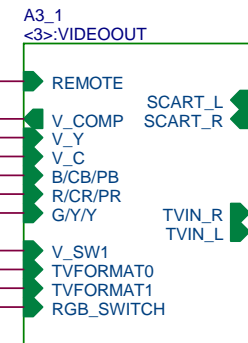
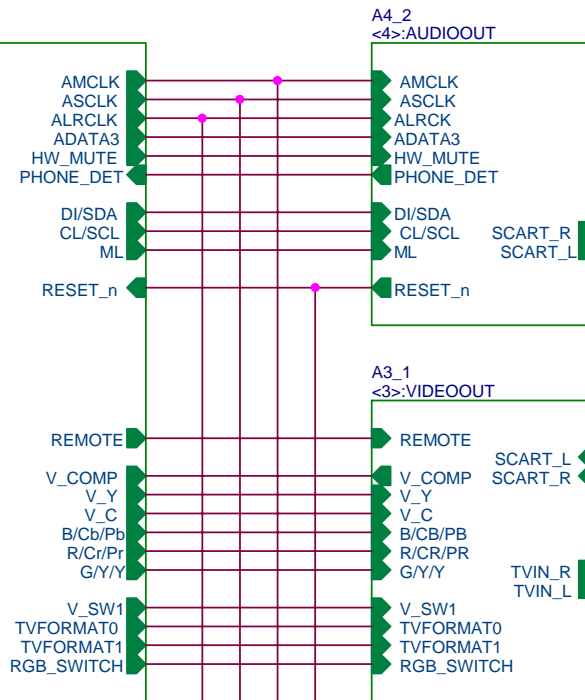
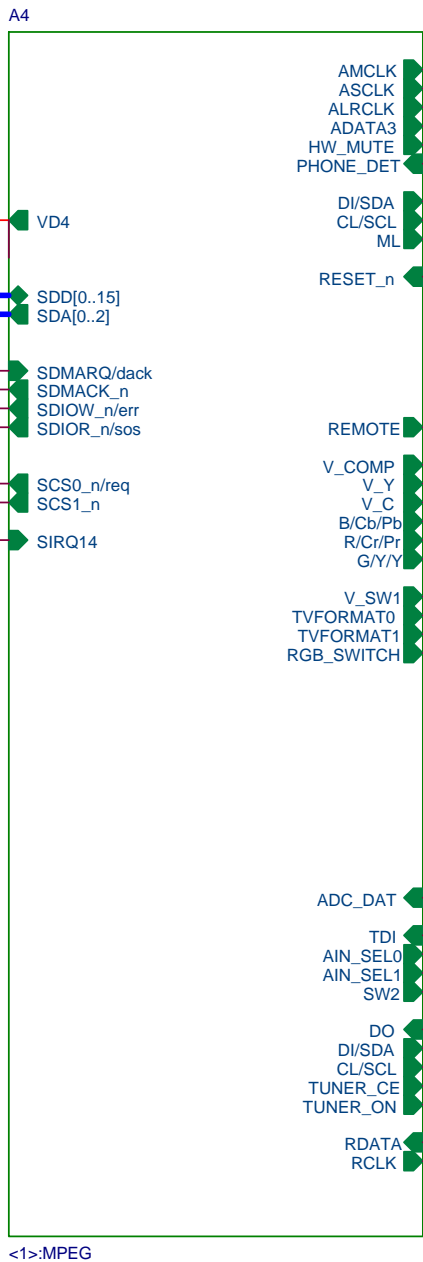
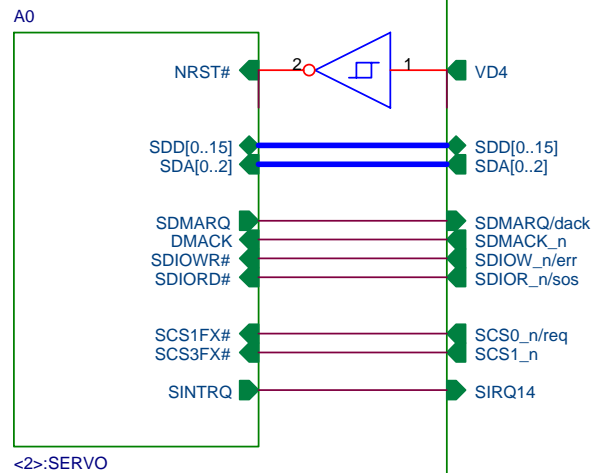

harman / kardon®

Harman Kardon, Northridge, California 91329, USA

Title DSC1000 MAIN BOARD 041011

Size A4	Document Number 1239C-PV1	Rev 3.3
------------	------------------------------	------------

Date: Tuesday, November 30, 2004 Sheet 2 of 22

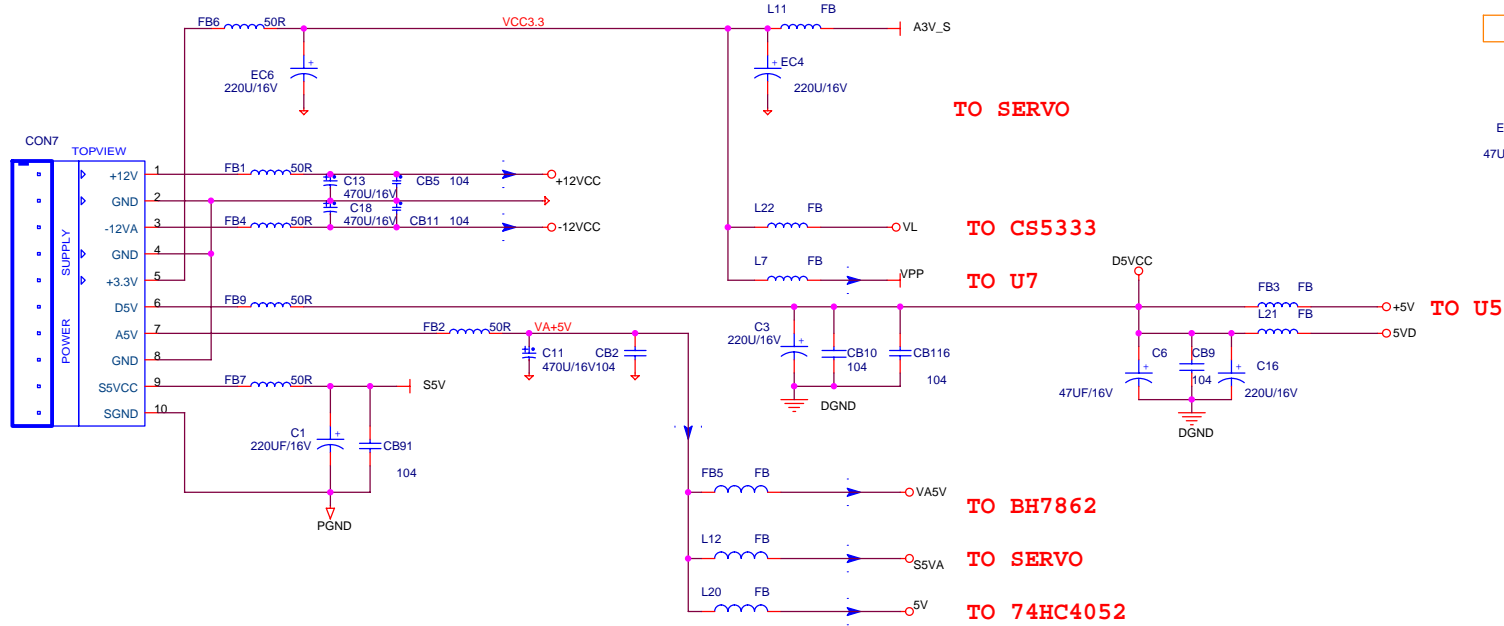

FOR LM833&NJM4558

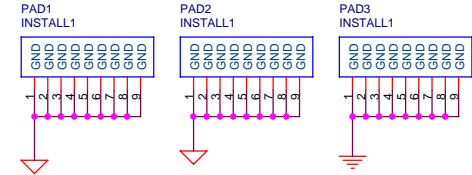
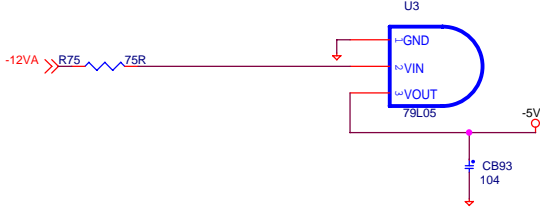
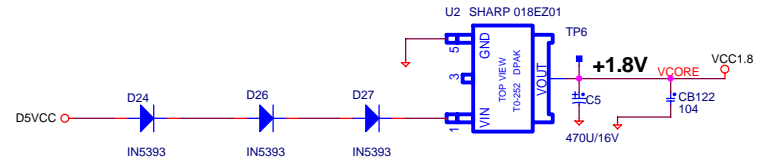
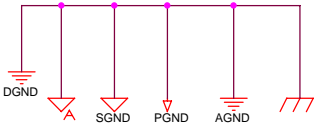
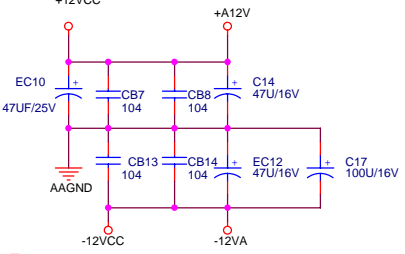

AML3370

U4

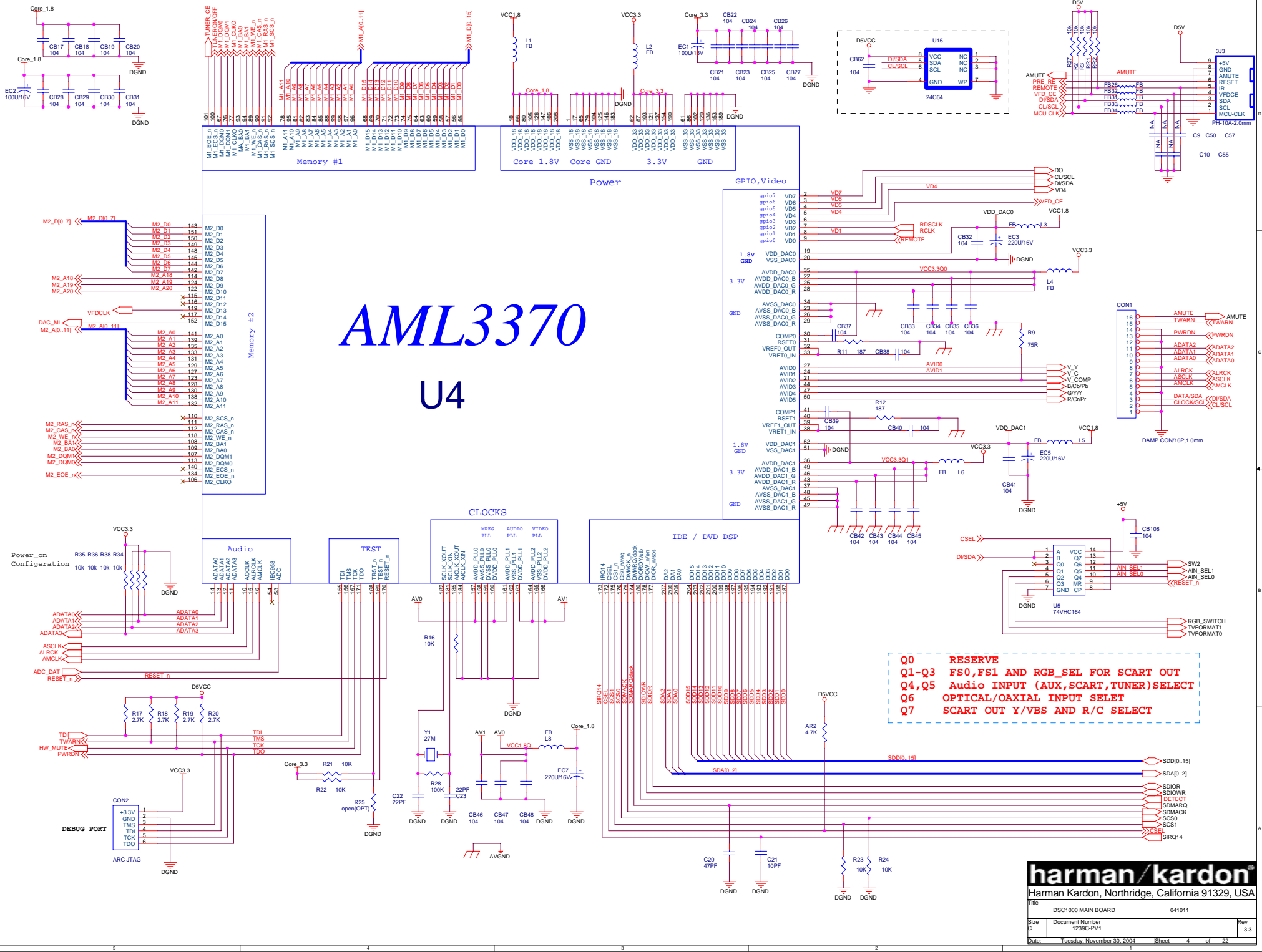

Q0 RESERVE
 Q1-Q3 FS0,FS1 AND RGB_SEL FOR SCART OUT
 Q4,Q5 Audio INPUT (AUX,SCART,TUNER)SELECT
 Q6 OPTICAL/OXIAL INPUT SELECT
 Q7 SCART OUT Y/VBS AND R/C SELECT

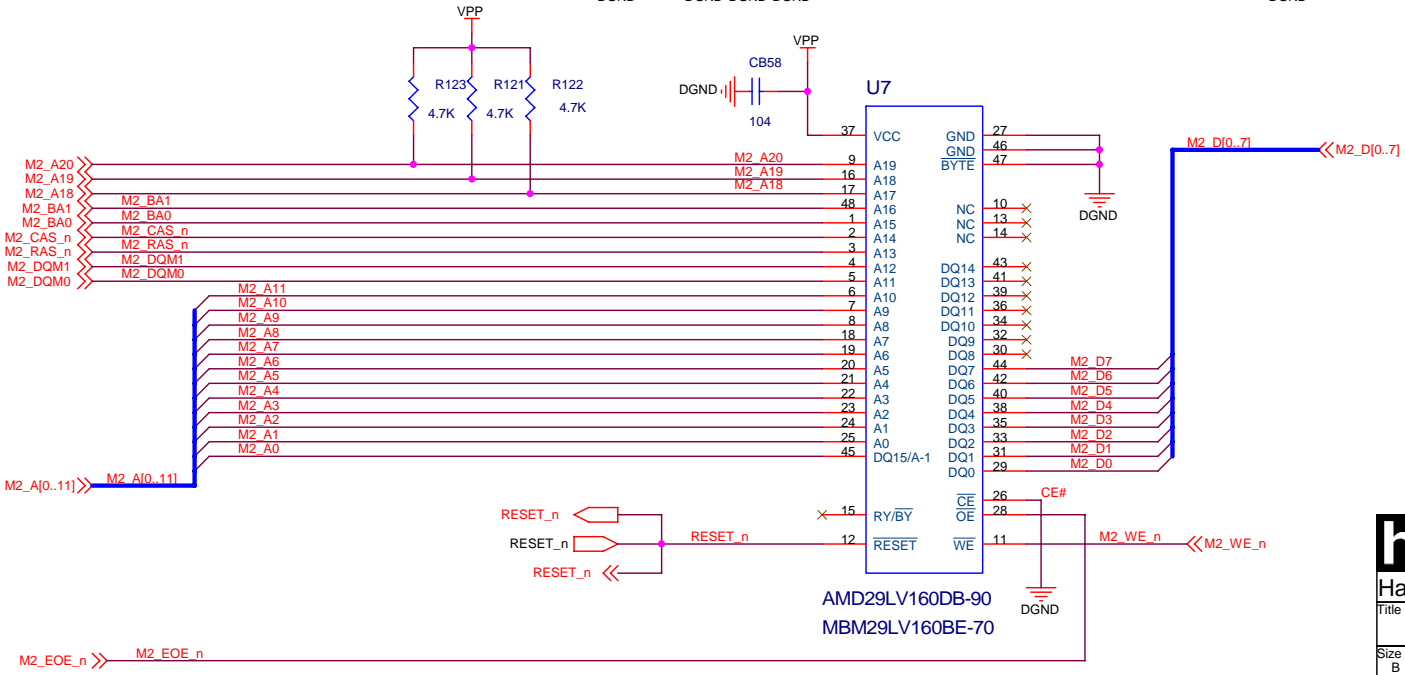
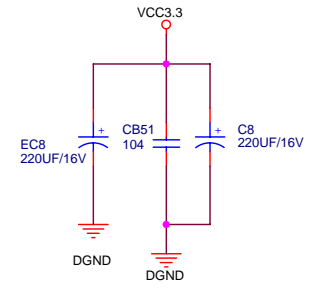
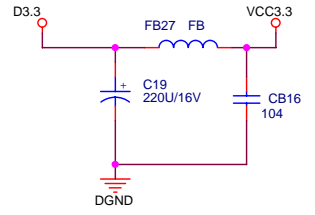
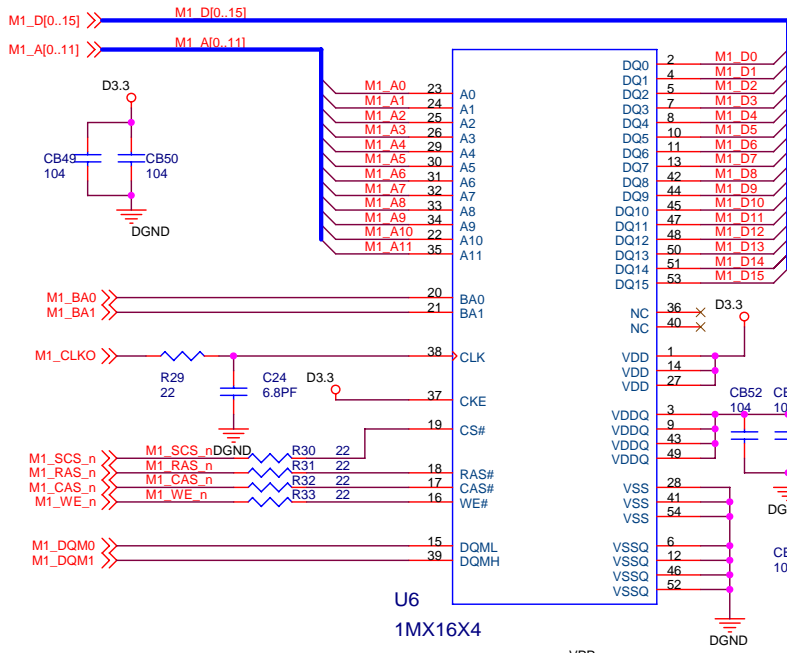

harman/kardon
 Harman Kardon, Northridge, California 91329, USA

Title: DSC1000 MAIN BOARD 041011

Size B Document Number 1239C-PV1 Rev 3.3

Date: Tuesday, November 30, 2004 Sheet 5 of 22

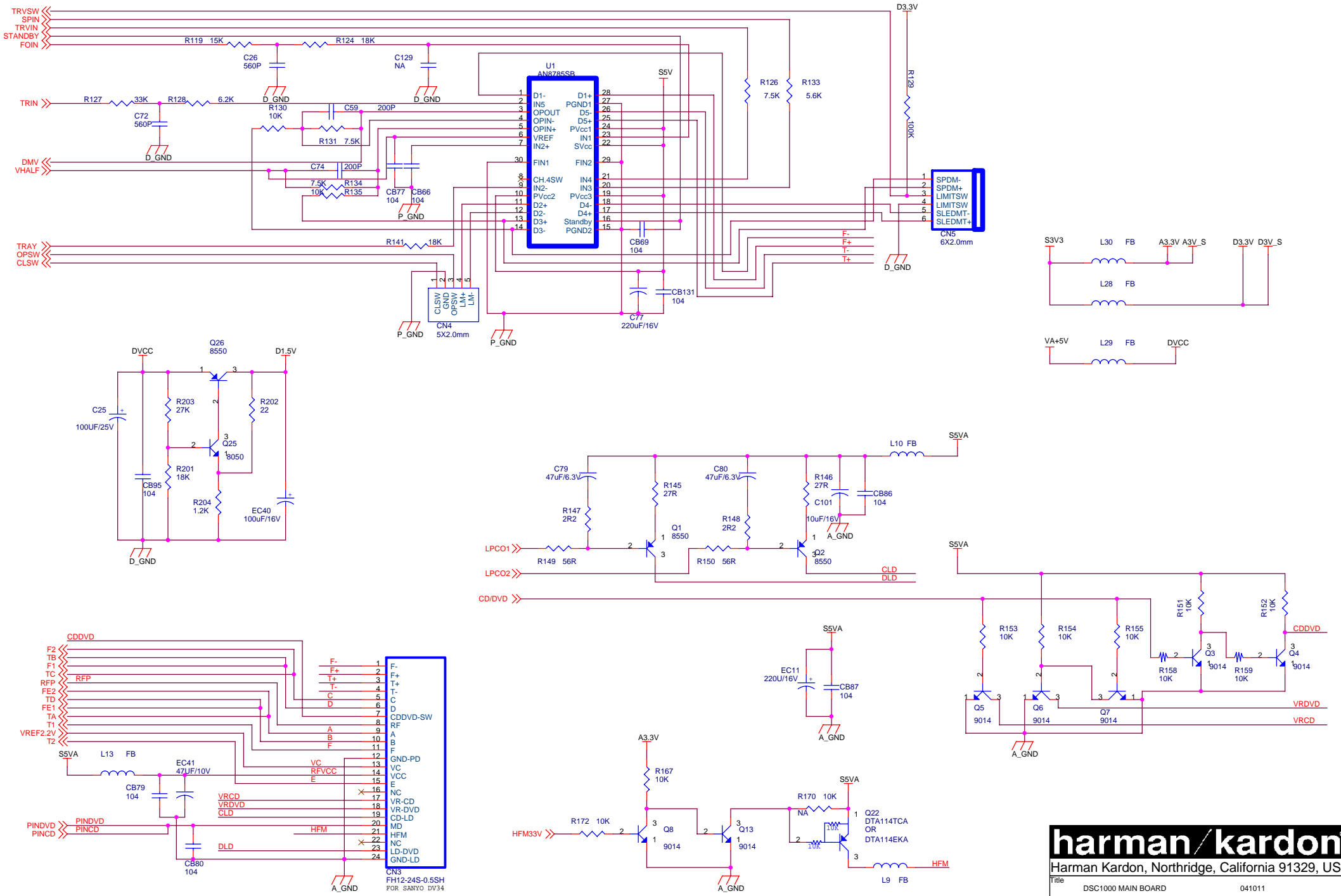

harman/kardon
 Harman Kardon, Northridge, California 91329, USA

Title	DSC1000 MAIN BOARD	041011
Size	Document Number	Rev
A3	1239C-PV1	3.3
Date:	Tuesday, November 30, 2004	Sheet 6 of 22

VIDEO

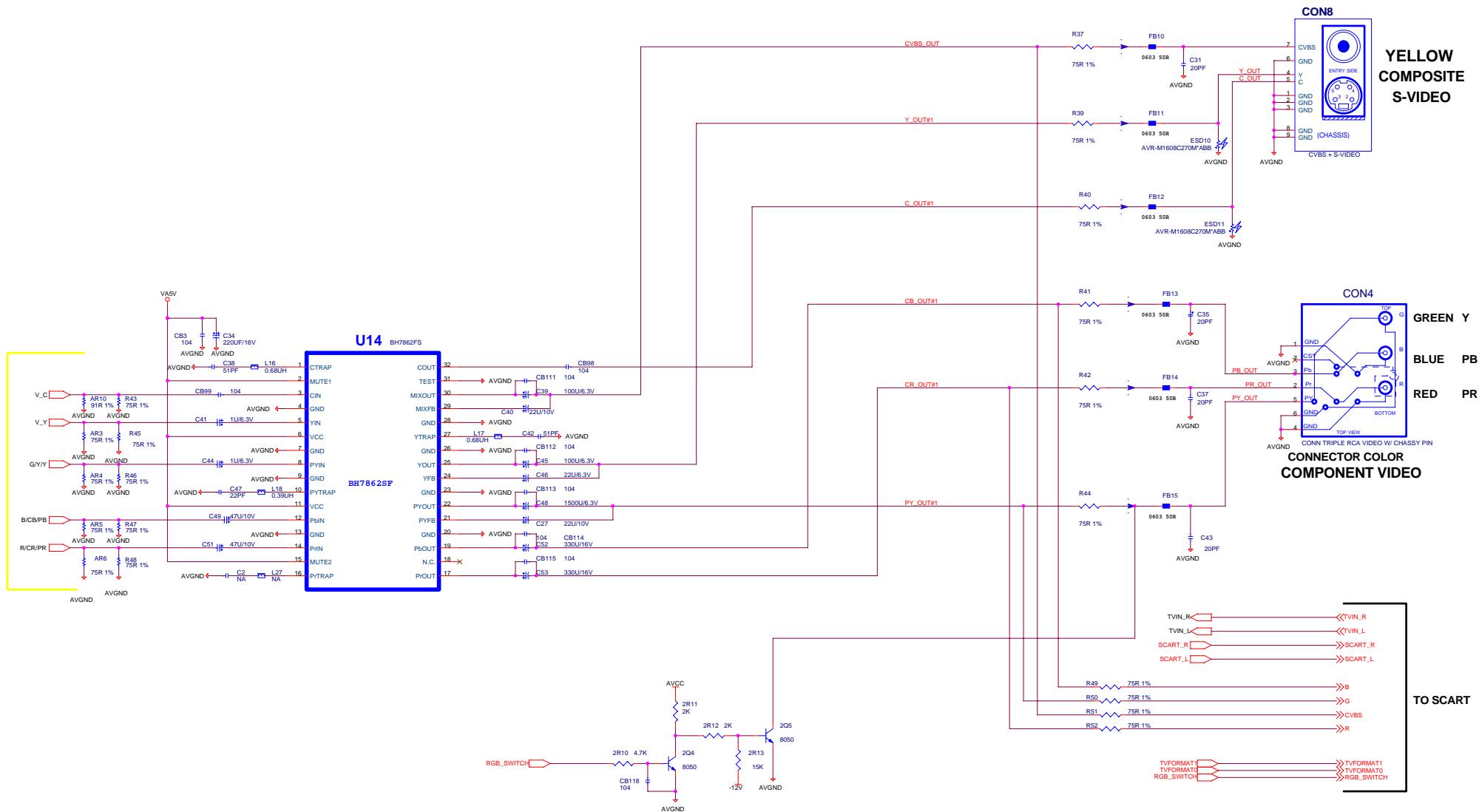

**YELLOW
COMPOSITE
S-VIDEO**

**GREEN Y
BLUE PB
RED PR**

**CONNECTOR COLOR
COMPONENT VIDEO**

TO SCART

SCART

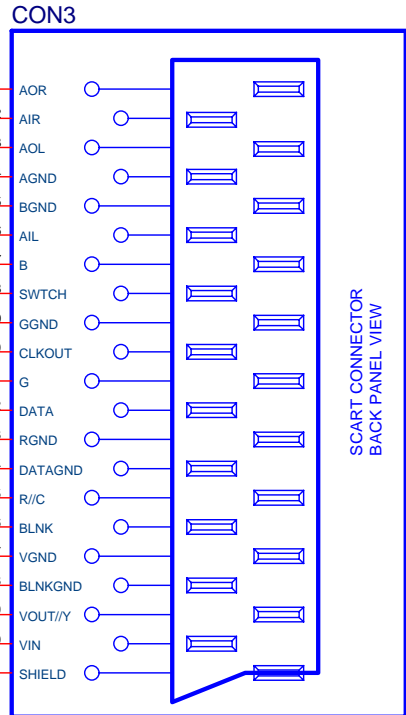
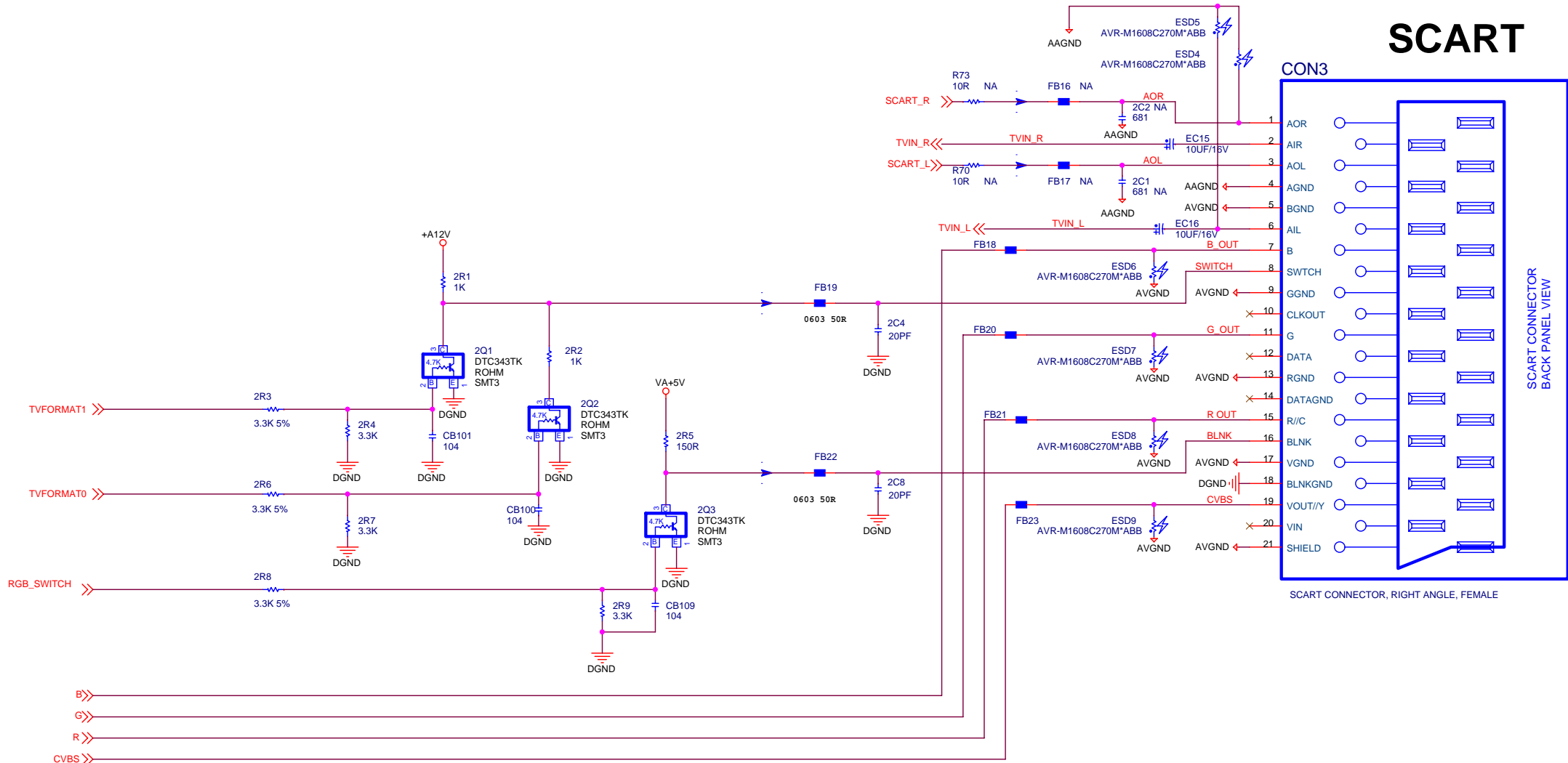

SCART CONNECTOR, RIGHT ANGLE, FEMALE

RGBSWITCH	TVFORMAT0	TVFORMAT1	TV FUNCTION	PIN8 (V)	PIN16 (V)
X	0	1	SCART Inactive (Standby)	0V	X
X	0	0	SCART Active Auto Switch to 4:3 Aspect Ratio	12V	X
X	1	0	SCART Active Auto Switch to 16:9 Aspect Ratio	6V	X
0	X	X	RGB	X	1-3V
1	X	X	CVBS	X	0-0.4V

harman/kardon[®]
 Harman Kardon, Northridge, California 91329, USA

Title: DSC1000 MAIN BOARD 041012

Size B Document Number 1239C-PV1 Rev 3.3

Date: Tuesday, November 30, 2004 Sheet 9 of 22

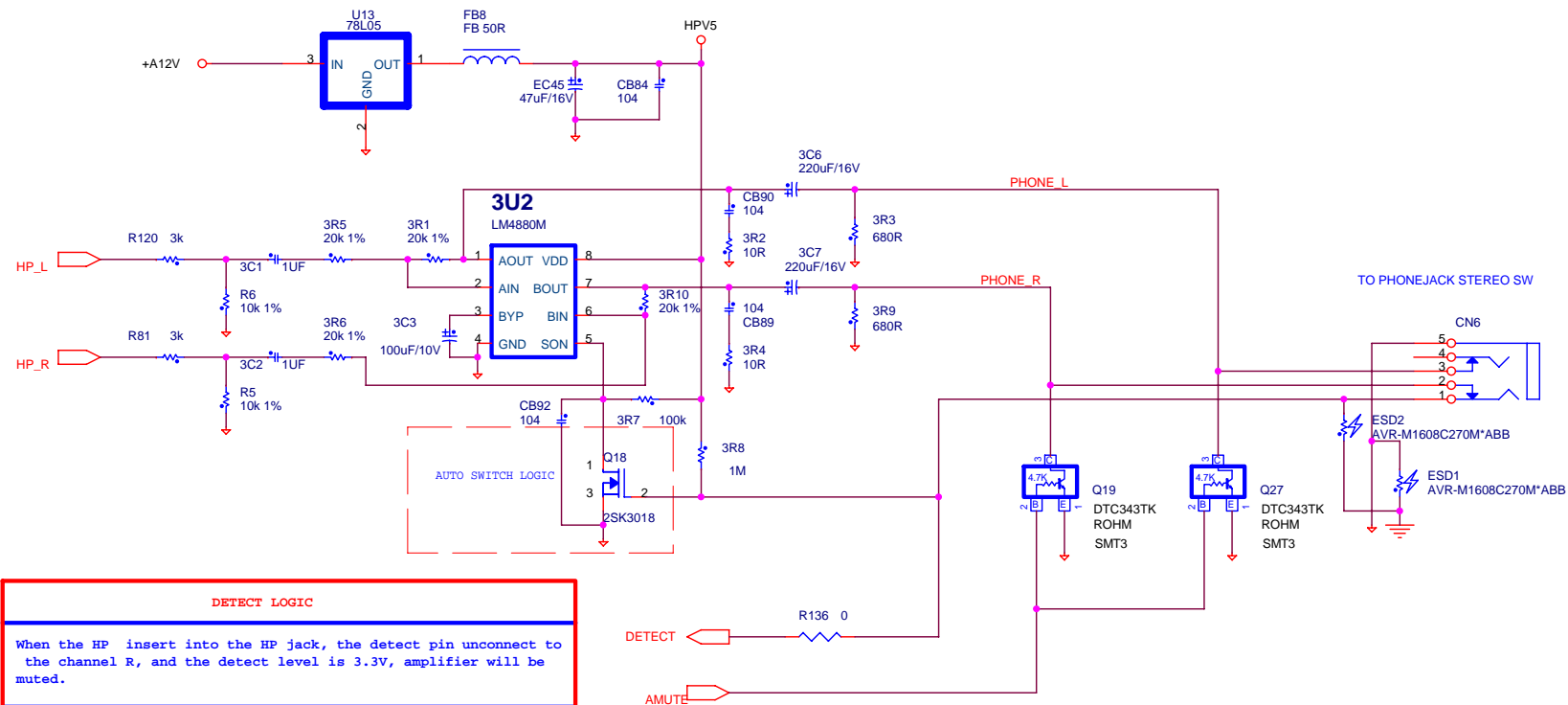

DETECT LOGIC

When the HP insert into the HP jack, the detect pin unconnect to the channel R, and the detect level is 3.3V, amplifier will be muted.

When the HP doesn't insert into the HP jack, the detect pin will connect to the channel R, and the detect level is 0V, amplifier will work normally.

harman/kardon®
 Harman Kardon, Northridge, California 91329, USA

Title	DSC1000 MAIN BOARD	041011
Size	Document Number	Rev
B	1239C-PV1	3.3
Date:	Tuesday, November 30, 2004	Sheet 11 of 22

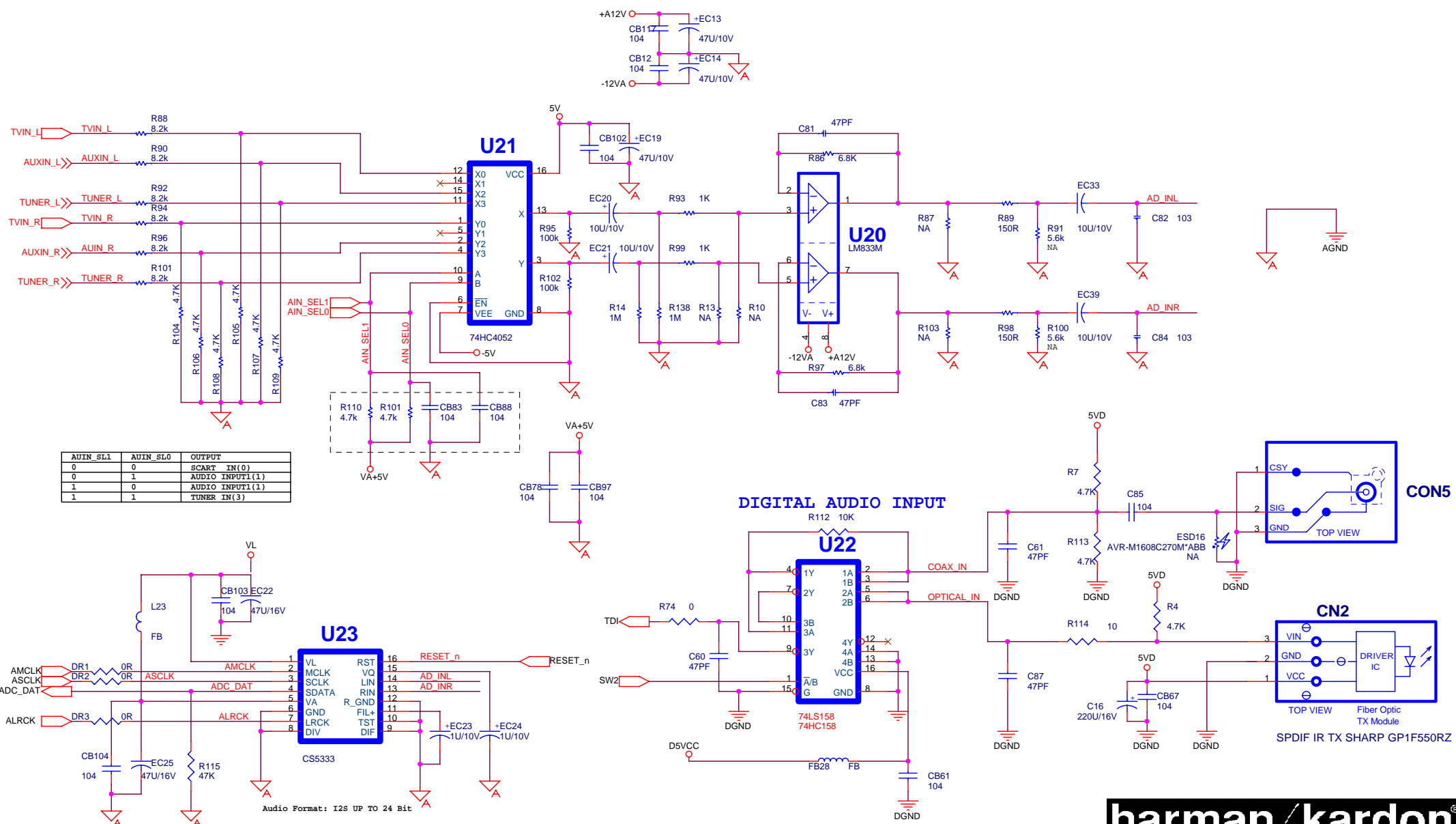

AUIN_SL1	AUIN_SL0	OUTPUT
0	0	SCART_IN(0)
0	1	AUDIO_INPUT1(1)
1	0	AUDIO_INPUT1(1)
1	1	TUNER_IN(3)

Audio Format: I2S UP TO 24 Bit

harman/kardon
 Harman Kardon, Northridge, California 91329, USA

Title: DSC1000 MAIN BOARD 041011

Size B Document Number 1239C Rev 3.3

Date: Tuesday, November 30, 2004 Sheet 12 of 22

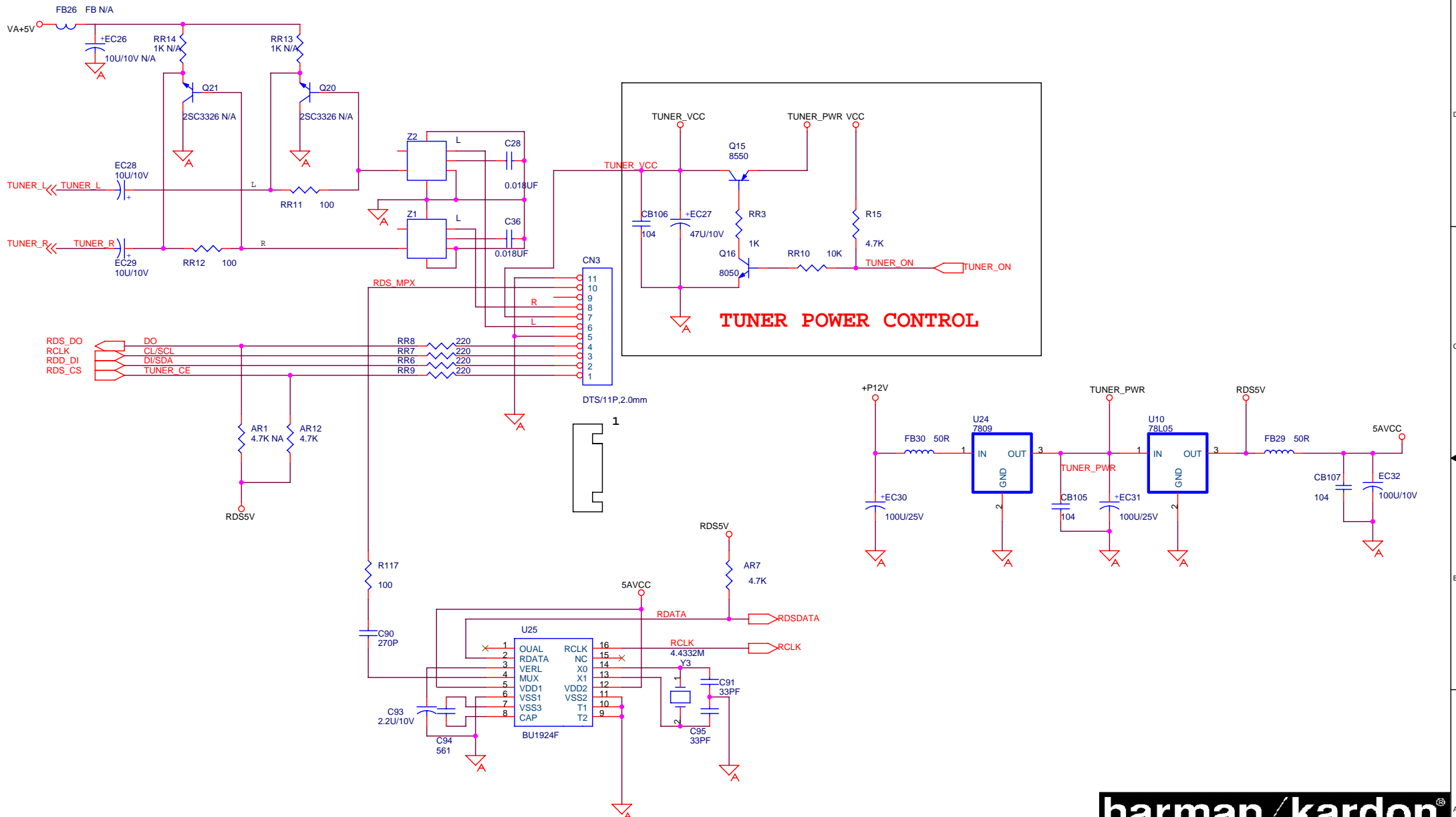

harman/kardon®
 Harman Kardon, Northridge, California 91329, USA

Title	DSC1000 MAIN BOARD	041011
Size	Document Number	Rev
B	1239C	3.3
Date:	Tuesday, November 30, 2004	Sheet 13 of 22

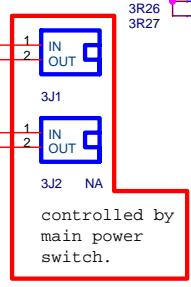
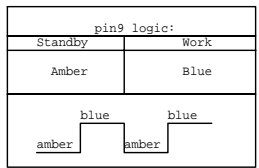
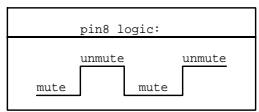
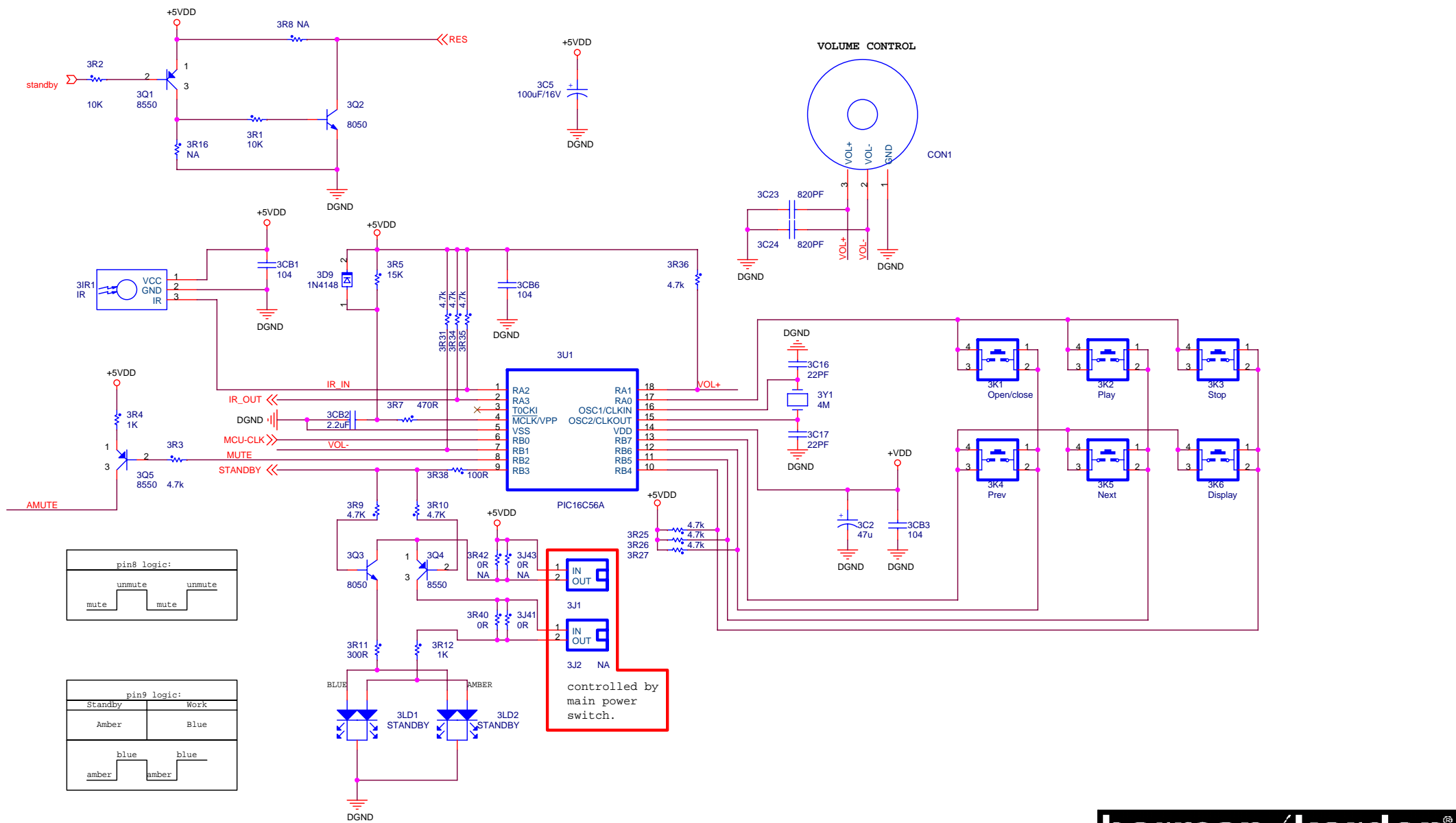

harman/kardon[®]
 Harman Kardon, Northridge, California 91329, USA

Title: DSC1000 FRONT PANEL 041005

Size B	Document Number 1242C	Rev 2.4
--------	-----------------------	---------

Date: Tuesday, November 30, 2004 Sheet 14 of 22

FOR DDX2100

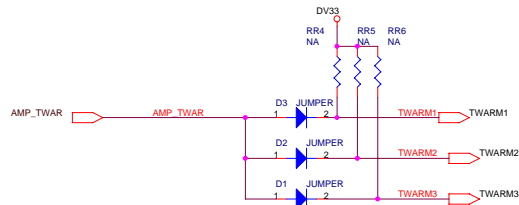
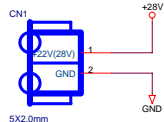

FOR DDX8000

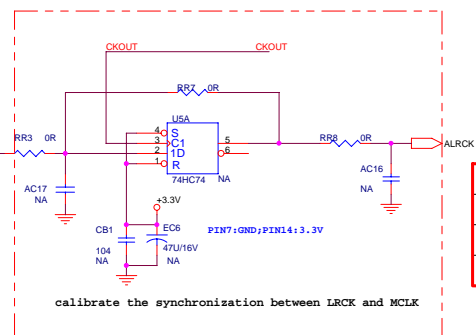
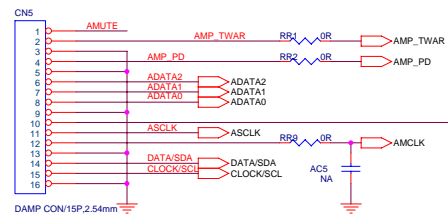
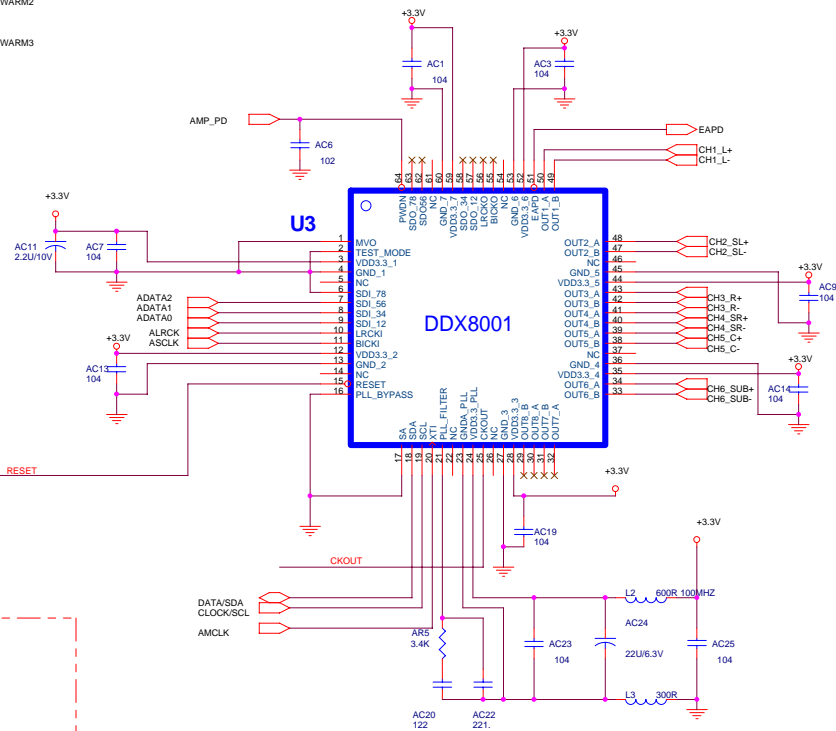
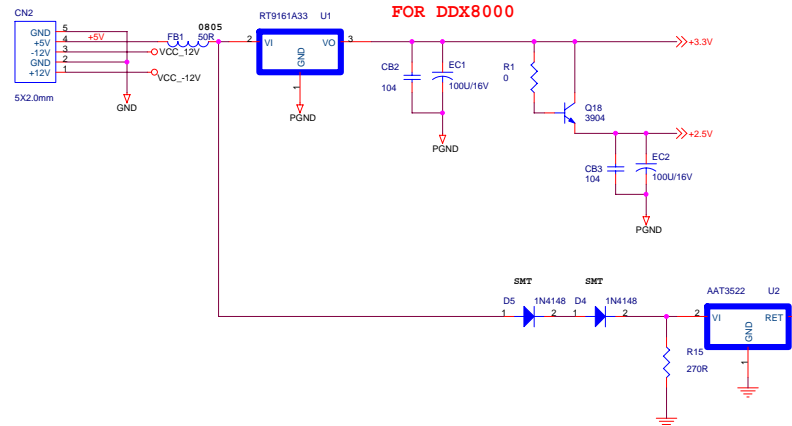

SELECTION:

	RR3	AC17	RR7	RR8	AC16	RR9	ACS	U5
Option 1	0 ohm	NA	NA	0 ohm	NA	0 ohm	NA	ON
Option 2	0 ohm	NA	0ohm	0 ohm	NA	0 ohm	NA	NA

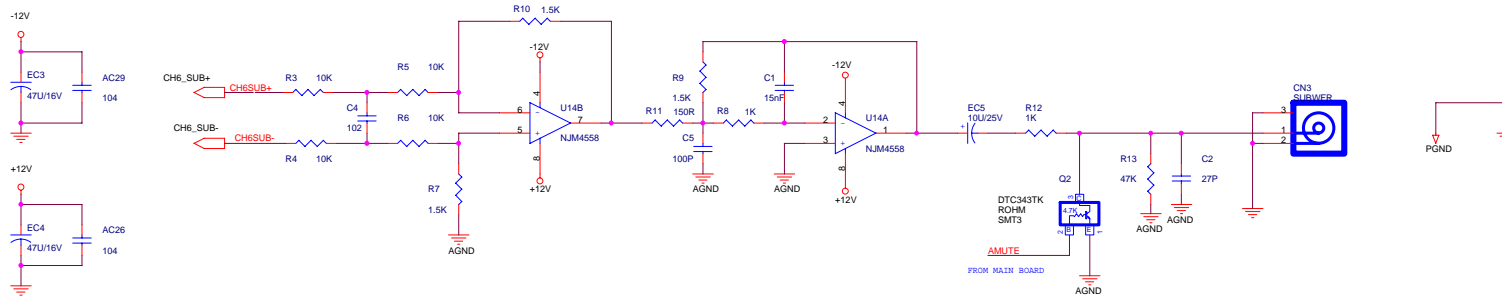

Harman Kardon, Northridge, California 91329, USA

File	DSC1000 AMP BOARD	041130
Size	Document Number	Rev
C	1241C	1.7
Date	Tuesday, November 30, 2004	Sheet 20 of 22

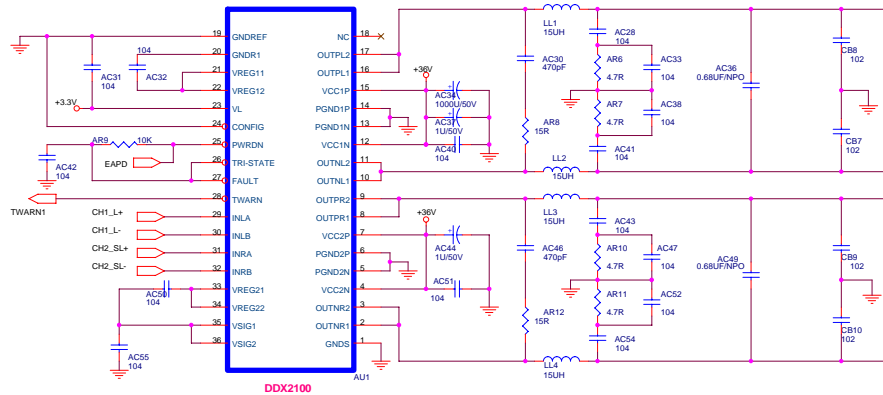

DDX2100

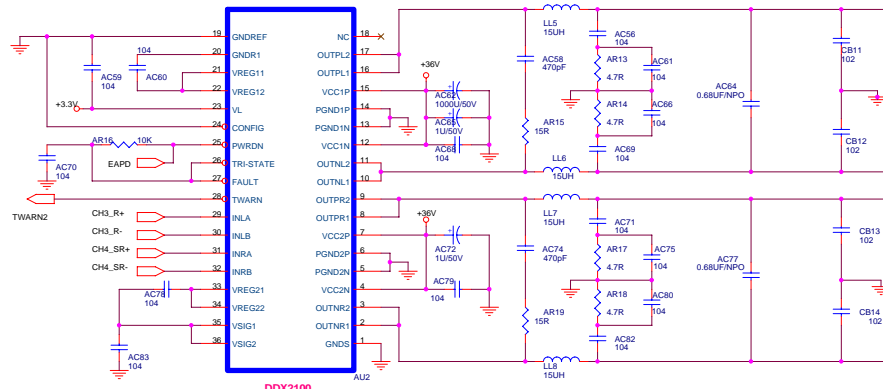

DDX2100

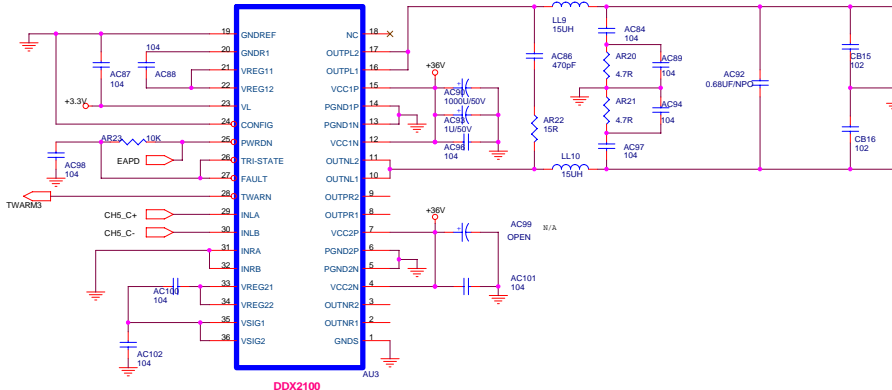

DDX2100

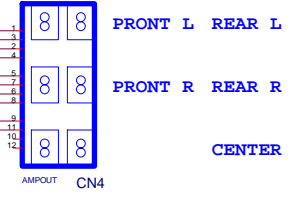

harman/kardon
 Harman Kardon, Northridge, California 91329, USA

Doc	DSC1000 AMP BOARD	040925
Doc	Document Number	Rev
A4	1241C	1.7
Date:	Tuesday, November 30, 2004	Sheet 21 of 22

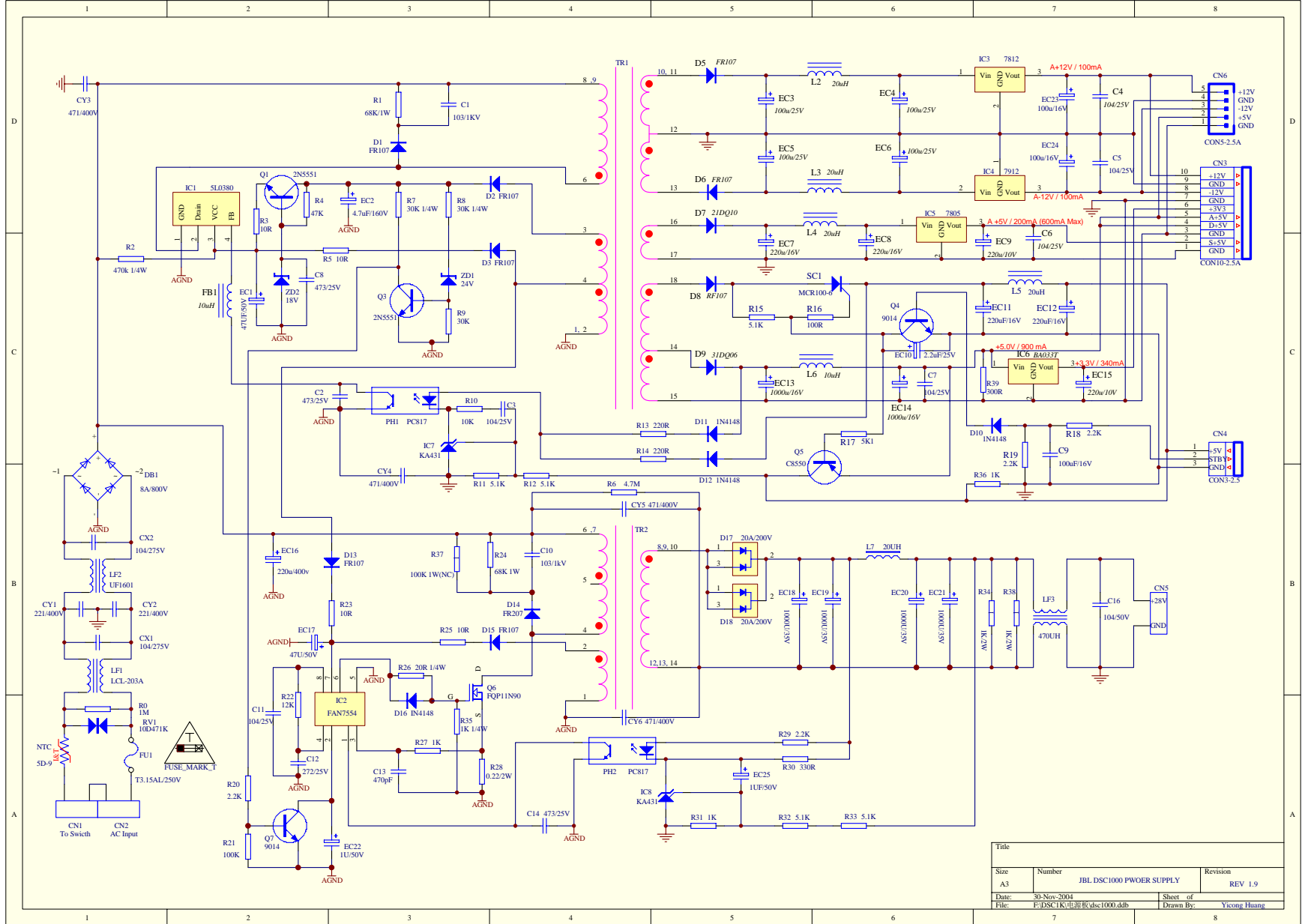

Title			
Size	Number	JBL DSC1000 PWOER SUPPLY	Revision
A3			REV 1.9
Date:	30-Nov-2004	Sheet of	
File:	F:\DSC1K\电源板\dsc1000.dtb	Drawn By:	Yicong Huang

