



AMC3842A/43A/44A/45A

CURRENT MODE PWM CONTROLLER

DESCRIPTION	FEATURES
<p>The AMC3842A/43A/44A/45A are fixed frequency current-mode PWM controllers specially designed for OFF-Line switching power supply and DC-to-DC converters with a minimum number of external components. These devices feature a trimmed oscillator for precise duty cycle control, a temperature compensated reference, high gain error amplifier, current sensing comparator, and high current totem pole output which is suitable for driving MOSFETs.</p> <p>The under voltage lock-out (U.V.L.O.) is designed to operated with 200μA typ. start-up current, allowing an efficient bootstrap supply voltage design. The U.V.L.O. thresholds for the AMC3842A/44A are 16V (on) and 10V (off) which are ideal for off-line applications. The corresponding typical threshold for the AMC3843A/45A are 8.4V (on) and 7.6V (off). The AMC3842A/43A can operated within 100% duty cycle and the AMC3844A/45A can operated within 50% duty cycle.</p>	<ul style="list-style-type: none"> ■ Low Start-Up current (typ. 200μA) ■ Optimized for Off-Line and DC-to-DC Converters ■ Maximum Duty Cycle ■ U.V.L.O. with Hysteresis □ Operating Frequency Up to 500KHz □ Internal Trimmed Bandgap Reference □ High Current Totem Pole Output □ Error Amplifier With Low Output Resistance □ Available in 8-Pin Plastic DIP and Surface Mount 14-Pin S.O.I.C. □ Identical pin assignment to earlier UC384X series.

APPLICATIONS	PACKAGE PIN OUT																				
<ul style="list-style-type: none"> ■ Off-line flyback or forward converters. ■ DC-to-DC buck or boost converter. ■ Monitor Power Supply 	<p>8-Pin Plastic DIP (Top View)</p>																				
AVAILABLE OPTIONS																					
<table border="1" style="width: 100%; border-collapse: collapse;"> <thead> <tr> <th>Device</th> <th>Start-UP Voltage</th> <th>Hysteresis</th> <th>Max. Duty Cycle</th> </tr> </thead> <tbody> <tr> <td>AMC3842A</td> <td>16V</td> <td>6V</td> <td>< 100%</td> </tr> <tr> <td>AMC3843A</td> <td>8.4V</td> <td>0.8V</td> <td>< 100%</td> </tr> <tr> <td>AMC3844A</td> <td>16V</td> <td>6V</td> <td>< 50%</td> </tr> <tr> <td>AMC3845A</td> <td>8.4V</td> <td>0.8V</td> <td>< 50%</td> </tr> </tbody> </table>	Device	Start-UP Voltage	Hysteresis	Max. Duty Cycle	AMC3842A	16V	6V	< 100%	AMC3843A	8.4V	0.8V	< 100%	AMC3844A	16V	6V	< 50%	AMC3845A	8.4V	0.8V	< 50%	<p>14-Pin Plastic S.O.I.C. Surface Mount (Top View)</p> <p>8-Pin Plastic S.O.I.C. Surface Mount (Top View)</p>
Device	Start-UP Voltage	Hysteresis	Max. Duty Cycle																		
AMC3842A	16V	6V	< 100%																		
AMC3843A	8.4V	0.8V	< 100%																		
AMC3844A	16V	6V	< 50%																		
AMC3845A	8.4V	0.8V	< 50%																		

ORDER INFORMATION						
T_A (°C)	M	Plastic DIP-8 8-pin	D	Plastic SO-14 14-pin	DM	Plastic SO-8 8-pin
0 to 70		AMC384XAM		AMC384XAD		AMC384XADM
0 to 70		AMC384XAMF(Lead Free)		AMC384XADF(Lead Free)		AMC384XADMF(Lead Free)
Note: 1.All surface-mount packages are available in Tape & Reel. Append the letter "T" to part number (i.e. AMC384XADT, or AMC384XADMT). 2.The letter "F" is marked for Lead Free process.						

AMC3842A/43A/44A/45A

CURRENT MODE PWM CONTROLLER

ABSOLUTE MAXIMUM RATINGS (Note 1)	
Supply voltage, V_{CC}	35V
Output current, I_O	$\pm 1A$
Analog inputs, V_I	-0.3V to 6.3V
Error amp output sink current, $I_{SINK(EA)}$	10mA
Power dissipation ($T_A = 25^\circ C$), P_D	1W
Maximum junction temperature, T_J	150 $^\circ C$
Storage temperature range	-65 $^\circ C$ to 150 $^\circ C$
Lead temperature (soldering, 10 seconds)	260 $^\circ C$
Note 1: Exceeding these ratings could cause damage to the device. All voltages are with respect to Ground. Currents are positive into, negative out of the specified terminal.	

THERMAL DATA	
M PACKAGE:	
Thermal Resistance-Junction to Ambient, θ_{JA}	95 $^\circ C/W$
D PACKAGE:	
Thermal Resistance-Junction to Ambient, θ_{JA}	120 $^\circ C/W$
DM PACKAGE:	
Thermal Resistance-Junction to Ambient, θ_{JA}	165 $^\circ C/W$
Junction Temperature Calculation: $T_J = T_A + (P_D \times \theta_{JA})$. The θ_{JA} numbers are guidelines for the thermal performance of the device/pc-board system. All of the above assume no ambient airflow.	

AMC3842A/43A/44A/45A

CURRENT MODE PWM CONTROLLER

BLOCK DIAGRAM

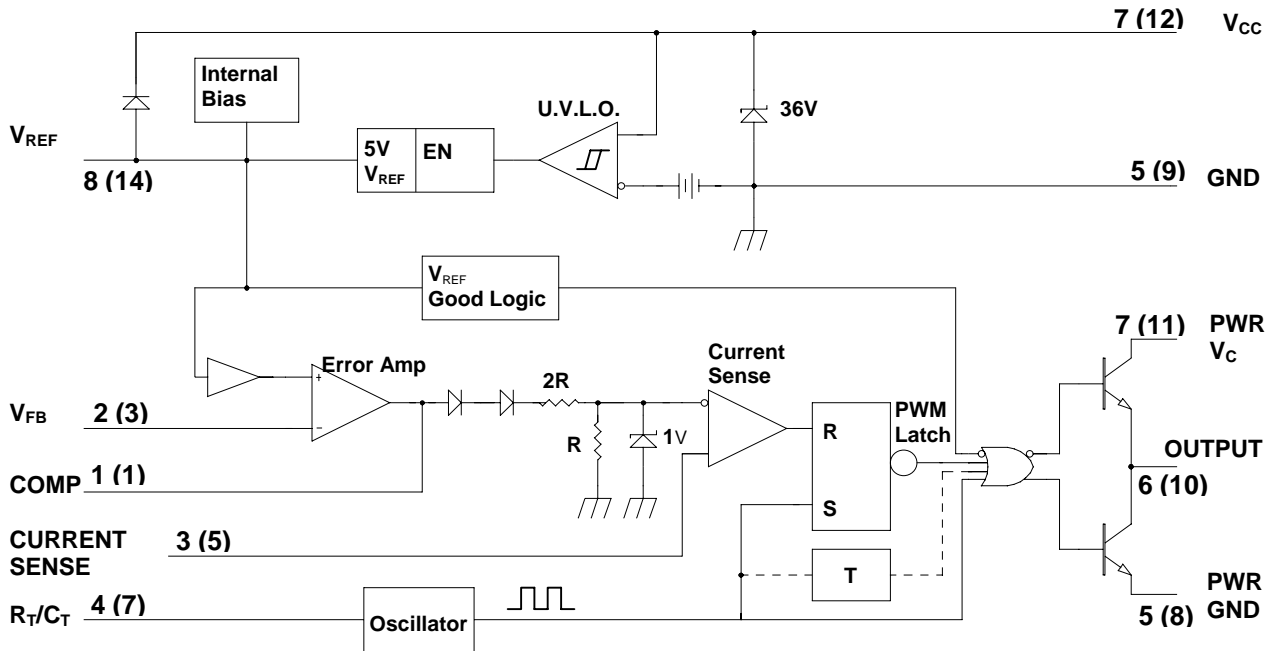

() are 14 Pin S.O.I.C. pin number

Note 2 : V_{CC} and PWR V_C are internally connected for 8 pin packages.

Note 3 : PWR GND and GND are internally connected for 8 pin packages.

Note 4 : Toggle flip flop used only in 3844A/45A.

Note 5 : U.V.L.O. is 16V for 3842A/44A and 8.4V for 3843A/45A.

Note 6 : Hysteresis is 6V for 3842A/44A and 0.8V for 3843A/45A.

AMC3842A/43A/44A/45A

CURRENT MODE PWM CONTROLLER

RECOMMENDED OPERATING CONDITIONS					
Parameter	Symbol	Recommended Operating Conditions			Units
		Min.	Typ.	Max.	
Supply Voltage	V_{CC} / V_C			30	V
Input Voltage	$V_{I,R_T/C_T}$	0		5.5	V
	$V_{I,I_{SENSE}/V_{FB}}$				
Output Voltage	$V_{O, Output}$	0		30	V
Supply Current	I_{CC}			25	mA
Average Output Current	I_O			200	mA
Reference Output Current	$I_{O(REF)}$			-20	mA
Timing Capacitor	C_T	1			nF
Oscillator Frequency	f_{OSC}		100	500	KHz
Operating Free-air Temperature	T_A	0		70	°C

ELECTRICAL CHARACTERISTICS						
Unless otherwise specified, these specifications apply over the operating ambient temperature for AMC384XA with $0^{\circ}\text{C} \leq T_A \leq 70^{\circ}\text{C}$; $V_{CC} = 15\text{V}$ (note 7); $R_T = 10\text{K}$; $C_T = 3.3\text{nF}$. Low duty cycle pulse testing techniques are used which maintains junction and case temperatures equal to the ambient temperature.						
Parameter	Symbol	Test Conditions	AMC384XA			Units
			Min.	Typ.	Max.	
Reference Section						
Reference output Voltage	V_{REF}	$T_J = 25^{\circ}\text{C}, I_{REF} = 1\text{mA}$	4.9	5.0	5.1	V
Line Regulation		$12\text{V} \leq V_{CC} \leq 25\text{V}, T_J = 25^{\circ}\text{C}$		6	20	mV
Load Regulation		$1\text{mA} \leq I_{REF} \leq 20\text{mA}$		6	25	mV
Short Circuit Output Current	I_{SC}	$T_J = 25^{\circ}\text{C}$	-30	-100	-180	mA
Oscillator Section						
Oscillation Frequency	f	$T_J = 25^{\circ}\text{C}$	47	52	57	KHz
Frequency Change with Voltage		$12\text{V} \leq V_{CC} \leq 25\text{V}$		0.2	1.0	%
Frequency Change with Temperature (note 8)		$T_{MIN} \leq T_A \leq T_{MAX}$		5		%
Peak-to-peak Amplitude At R_T/C_T	V_{OSC}			1.7		V
Current Sense Section						
Gain (note 9 & 10)	A_{VOL}		2.85	3.00	3.15	V/V
Maximum Input Signal (note 9)	$V_{I(MAX)}$	COMP = 5V	0.9	1.0	1.1	V
Power Supply Rejection Ratio (note 9)	PSRR	$12\text{V} \leq V_{CC} \leq 25\text{V}$ (note 9)		70		dB
Input Bias Current	I_{BIAS}			-3.0	-10	μA

AMC3842A/43A/44A/45A

CURRENT MODE PWM CONTROLLER

ELECTRICAL CHARACTERISTICS (Continued)						
Error Amplifier Section						
Input Bias Current	I_{BIAS}			-0.1	-2	μA
Input Voltage	$V_{I(EA)}$	COMP = 2.5V	2.42	2.50	2.58	V
Open Loop Voltage Gain	G_{VO}	$2V \leq V_O \leq 4V$	65	90		dB
Unity Gain Bandwidth (note 8)	UGBW	$T_J = 25^\circ C$	0.7	1		MHz
Power Supply Rejection Ratio	PSRR	$12V \leq V_{CC} \leq 25V$	60	70		dB
Output Sink Current	I_{SINK}	$V_{FB} = 2.7V, COMP = 1.1V$	2	7		mA
Output Source Current	I_{SOURCE}	$V_{FB} = 2.3V, COMP = 5.0V$	-0.5	-1.0		mA
High Output Voltage	V_{OH}	$V_{FB} = 2.3V, R_L = 15K\Omega$ to GND	5	6		V
Low Output Voltage	V_{OL}	$V_{FB} = 2.7V, R_L = 15K\Omega$ to V_{REF}		0.7	1.1	V
Output Section						
Output Low Level	V_{OL}	$I_{SINK} = 20mA$		0.1	0.4	V
		$I_{SINK} = 200mA$		1.4	2.2	
Output High Level	V_{OH}	$I_{SOURCE} = 20mA$	13	13.5		V
		$I_{SOURCE} = 200mA$	12	13.0		
Rise Time (note 8)	t_r	$T_J = 25^\circ C, C_L = 1nF$		50	150	ns
Fall Time (note 8)	t_f	$T_J = 25^\circ C, C_L = 1nF$		50	150	ns
Under-Voltage Lockout Section						
Start Threshold	$V_{TH(ST)}$	AMC3842A/44A	14.5	16.0	17.5	V
		AMC3843A/45A	7.8	8.4	9.0	
Min. Operating Voltage		AMC3842A/44A	8.5	10	11.5	V
		AMC3843A/45A	7.0	7.6	8.2	
PWM Section						
Maximum Duty Cycle		AMC3842A/43A	94	97	100	%
		AMC3844A/45A	47	48	50	
Minimum Duty Cycle					0	%
Total Standby Current						
Startup Current		AMC3842A/44A		0.2	0.35	mA
		AMC3843A/45A		0.5	1.0	
Operating Supply Current	I_{CC}	$V_{FB} = I_{SENSE} = 0V$		14	17	mA
Zener Voltage	V_Z	$I_{CC} = 25mA$	30	35		V
<p>note 7: Adjust V_{CC} above the start threshold before setting at 15V</p> <p>note 8: These parameters, although guaranteed, are not 100% tested in production prior to shipment</p> <p>note 9: Parameters are measured at trip point of latch with $V_{FB} = 2V$</p> <p>note 10: Gain is measured between I_{SENSE} and COMP with the input changing from 0V to 0.8V</p>						

Application Information

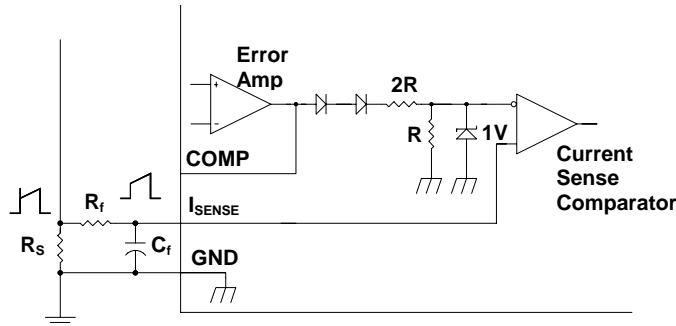

Fig. 1. Current Sense Circuit

Peak current (I_S) is set by: $I_{S(MAX)} = 1V/R_S$

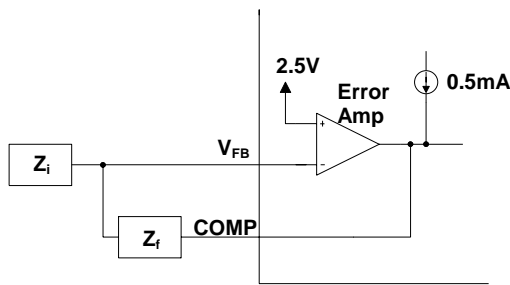

Fig. 2. Error Amplifier Configuration - the amplifier can source or sink up to 0.5mA

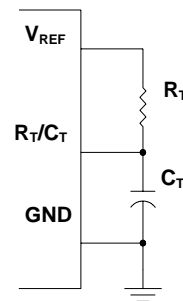

Fig. 3. Oscillator Section

For $R_T < 5K$, $f = \frac{1.72}{R_T C_T}$

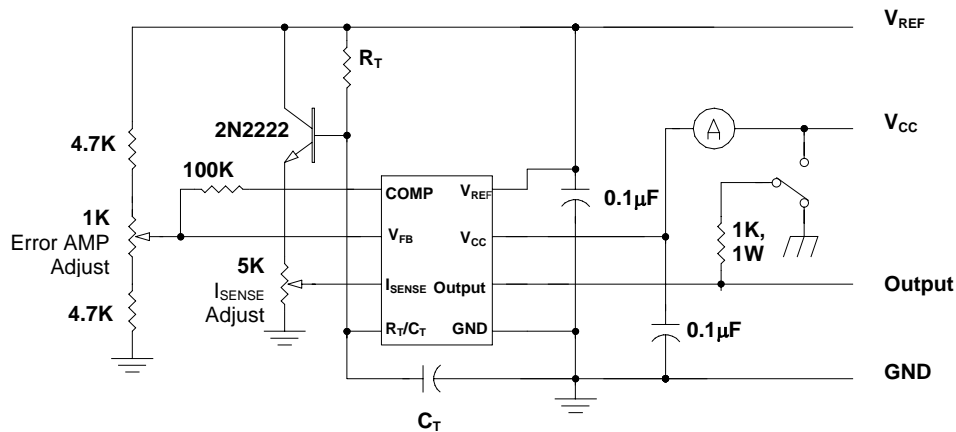

Fig. 4. Open-loop laboratory test fixture: Careful grounding techniques are necessary for high peak currents associated with capacitive loads. Timing and bypass capacitors should be connected to GND pin in a single point ground. The transistor and 5K potentiometer are used to sample the oscillator waveform and apply an adjustable ramp to the I_{SENSE} pin

Application Information (continued)

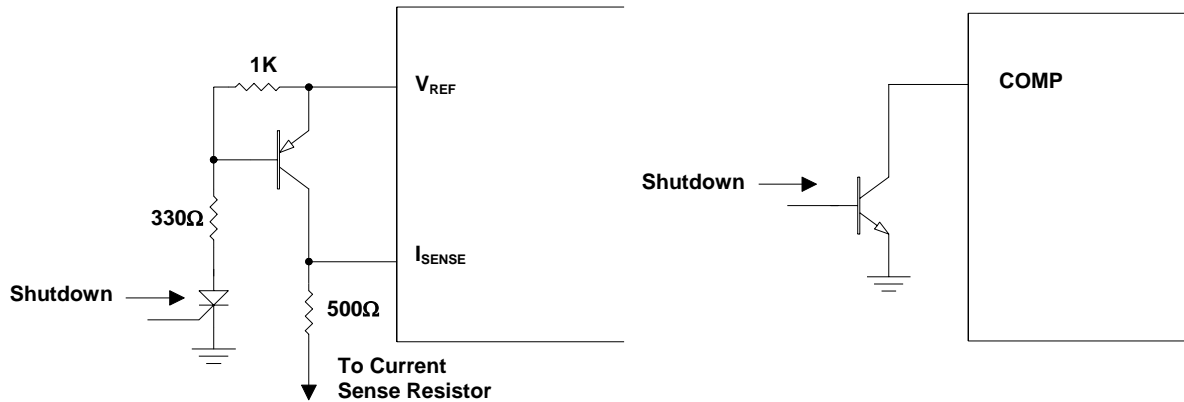

Fig. 5. Shutdown Techniques - there are two ways to shutdown the PWM controller: 1) raise the voltage at I_{SENSE} above 1V or, 2) pull the COMP below a voltage two diodes above ground.

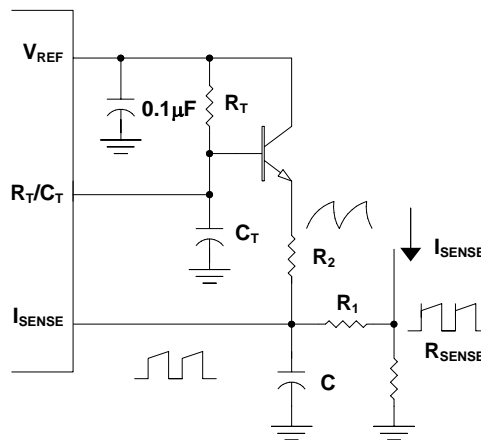
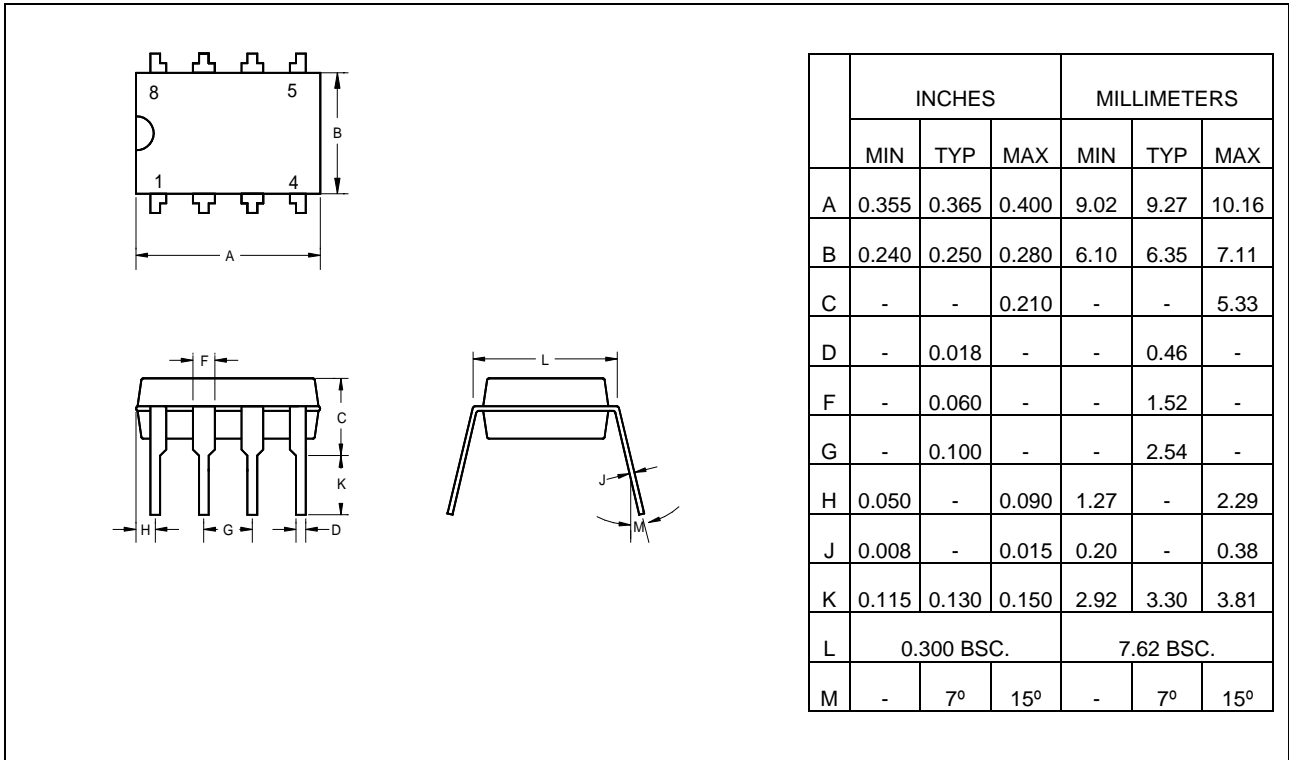

Fig 6. Slop Compensation – To achieve duty cycles over 50% for some applications , the above slope compensation technique is suggested by resistively summing a fraction of the oscillator ramp with the current sense signal.

AMC3842A/43A/44A/45A

CURRENT MODE PWM CONTROLLER

8-Pin Plastic DIP



8-Pin Plastic S.O.I.C.

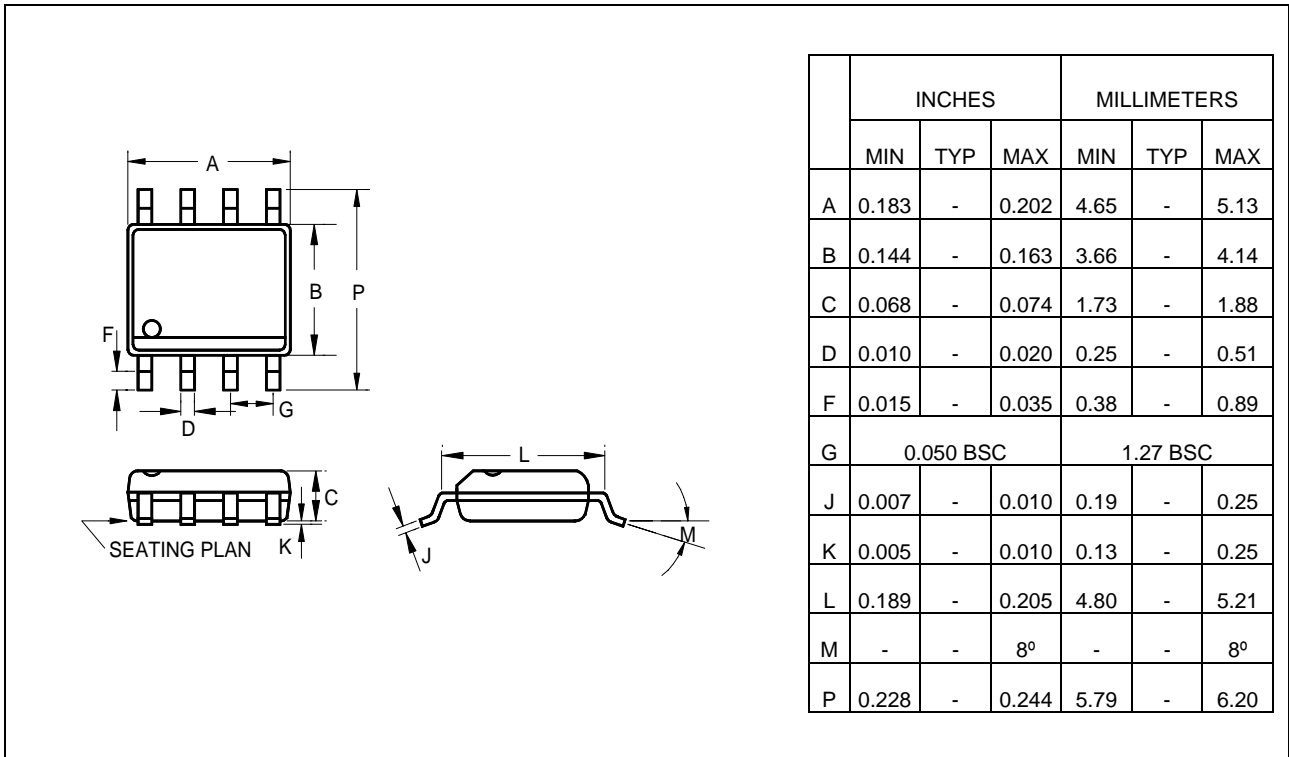

AMC3842A/43A/44A/45A

CURRENT MODE PWM CONTROLLER

14-Pin Plastic S.O.I.C.

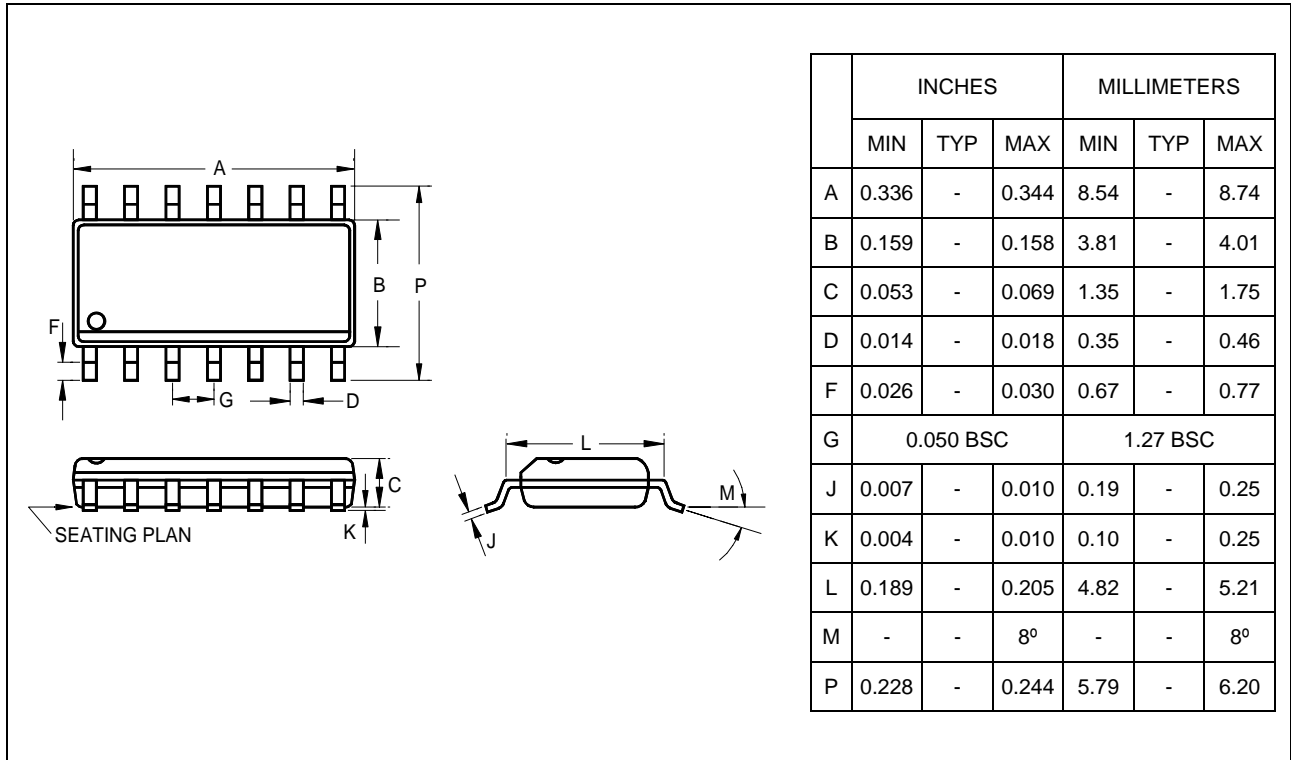

IMPORTANT NOTICE

ADD Microtech (ADDM) reserves the right to make changes to its products or to discontinue any integrated circuit product or service without notice, and advises its customers to obtain the latest version of relevant information to verify, before placing orders, that the information being relied on is current.

A few applications using integrated circuit products may involve potential risks of death, personal injury, or severe property or environmental damage. ADDM integrated circuit products are not designed, intended, authorized, or warranted to be suitable for use in life-support applications, devices or systems or other critical applications. Use of ADDM products in such applications is understood to be fully at the risk of the customer. In order to minimize risks associated with the customer's applications, the customer should provide adequate design and operating safeguards.

ADDM assumes no liability to customer product design or application support. ADDM warrants the performance of its products to the specifications applicable at the time of sale.

U.S.

ADD Microtech Inc.
492 Altamont Drive
Milpitas, CA 95035

TEL: (408) 9410420
FAX: (408) 9410864

Asia Pacific region

ADD Microtech Corp
13F, NO. 287, Sec. 3, Nan Jing E. Rd.,
Taipei, Taiwan 105

TEL: 2-27132800
FAX: 2-27132805
